

# WCT

Water cooled  
centrifugal chiller

# Product manual

Cooling Capacity from 7750 - 11400 kW

Performance according to EN14511  
Eurovent certified  
Refrigerant: R134a

CODE	
Date	
Supersedes	

# Table of Contents

Introduction.....	3
Dual Compressor Centrifugal Chillers.....	5
Unit Design Features.....	8
Control Features.....	10
Retrofit Disassembly.....	16
Options and Accessories .....	17
Factory Performance Test .....	18
AHRI Standard 575 Sound Ratings .....	18
Application Considerations.....	19
<b>Electrical Data</b> .....	22
Weights .....	24
Dimensions .....	25
Supplemental Publications.....	27
Specifications.....	28

Document:	Global CAT 615
Initial Issue:	March 13, 2012
Revision:	January 28, 2013
Replaces:	March 13, 2012

## Chiller Identification

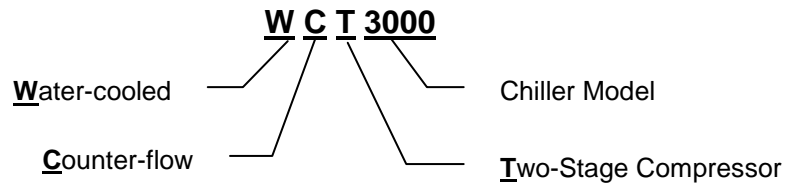

**Manufactured in an ISO Certified Facility**

©2013 McQuay International. Illustrations and data cover the McQuay International product at the time of publication and we reserve the right to make changes in design and construction at anytime without notice.

™® The following are trademarks or registered trademarks of their respective companies: BACnet from ASHRAE; LONMARK, LonTalk, LONWORKS, and the LONMARK logo are managed, granted and used by LONMARK International under a license granted by Echelon Corporation; Modbus from Schneider Electric; MicroTech II from McQuay International.

# Introduction

---

The Daikin McQuay Two-Stage Dual Centrifugal Water Chillers (WCT 3000) are complete, self-contained, automatically controlled fluid chilling units. Each unit is completely assembled and factory tested before shipment. These chillers have a separate refrigerant circuit for each compressor. They are available in single pass arrangement only. They provide the high full load efficiency advantage of two separate chillers arranged for counter flow operation in a single, compact unit.

The Daikin McQuay Model WCT 3000 Chillers use model K compressors and provide cooling capacity from 2500 tons (8800 kW) to 3000 tons (10500 kW). In the WCT series, each unit has two compressors and two economizers connected to a single condenser, and an evaporator. Each condenser and evaporator has two separate refrigerant circuits as each circuit producing from 125 tons (4400 kW) to 1500 ton (5280kW) cooling capacity.

The driveline of the WCT 3000 is made up of two two-stage compressors, each with a gear set and a 2-pole, induction semi-hermetic motor.

The controls are pre-wired, adjusted and tested. Only normal field connections such as water and relief valve piping, electrical and interlocks, etc. are required, thereby simplifying installation and increasing reliability. Most of the necessary equipment protection and operating controls are factory installed in the control panel.

All Daikin McQuay centrifugal chillers must be commissioned at the job site by a factory trained Daikin McQuay authorized technician.

The standard limited warranty on this equipment covers parts that prove defective in material or workmanship. Specific details of this warranty can be found in the warranty statement furnished with the equipment.

# Owner Benefits

## Excellent Performance

The Daikin McQuay WTC chillers have been designed from the beginning to provide extremely high operating efficiencies over the entire operating range, using a two-stage impeller and separate economizer vessel.

## Sustainable Performance

Although frequently overlooked, an important point to consider when selecting a chiller is the sustainability, over time, of the original purchased performance. All McQuay centrifugal chillers are positive pressure design, using R-134a refrigerant and the chiller performance is sustainable for the life of the unit.

## R-134a Refrigerant

Daikin McQuay WCT 3000 chillers use R-134a that offers the following distinct customer benefits.

- Positive Pressure Design
- No Purge Unit Maintenance
- No Annual Lubricant Maintenance
- No Vessel Heating Blankets and Energy Consumption
- No Refrigerant Availability Issue
- Smaller Equipment Rooms
- No Ozone Depletion

## Gear Drive Advantage

A gear-driven compressor runs at about the same tip speed, but tends to have less vibration than the larger, much heavier, direct-drive units. All Daikin McQuay compressors must pass a stringent vibration test while running on the production test stands.

Equipment noise and vibration are reduced.

## Refrigerant Storage Capability - Standard

The condensers on Daikin McQuay WCT chillers are sized to hold the entire chiller refrigerant charge and are provided with the necessary valves to isolate this charge. This feature eliminates the need for separate storage vessels in most applications.

## Daikin McQuay Startup

All Daikin McQuay centrifugal chillers are commissioned by McQuay Factory Service personnel, or by authorized and experienced Daikin McQuay startup technicians. This helps assure that proper starting and checkout procedures are employed and helps in a speedy commissioning process.

# Dual Compressor Centrifugal Chillers

## Dual Compressor Experience

McQuay is the expert when it comes to dual centrifugal compressor technology. We have been successfully building dual compressor centrifugal chillers since 1971.

## Benefits of Dual Compressor Chillers

### The Redundancy Feature

McQuay WCT 3000 dual centrifugal chillers have two of everything connected to the evaporator and condenser - two drivelines, two lubrication systems, two control systems, two expansion valves and two economizers.

If any component on a compressor system fails, the component can be removed or repaired without shutting down the other compressor; providing an automatic back-up with at least 50 percent of the chiller design capacity available..

Redundancy is also built into the distributed control system, which consists of a unit controller, a compressor controller and an expansion controller for each compressor and an operator interface touch screen.

- The chiller will operate normally without the operator interface touch screen being functional.
- If a compressor controller is unavailable, the other compressor will operate normally and handle as much of the load as possible.

### Lower Installed Costs

The redundancy feature pays off in lower installed costs. The elimination of the extra pumps, valves, piping, controls, rigging, and floor space can result in as much as a 35% reduction in the installation cost for a chiller plant, plus the savings on the chillers themselves.

## Dual Compressor Chiller Overview

There are subtle but important differences between the single circuit and two circuit chillers.

### Dual Circuit, WCT Counter Flow Chillers

These chillers have a separate refrigerant circuit for each compressor. They are available in single pass only. They provide the well known, high full load efficiency advantage of two separate chillers arranged for counter flow operation in a single, compact unit.

**Figure 1, Series Counter Flow Diagram**

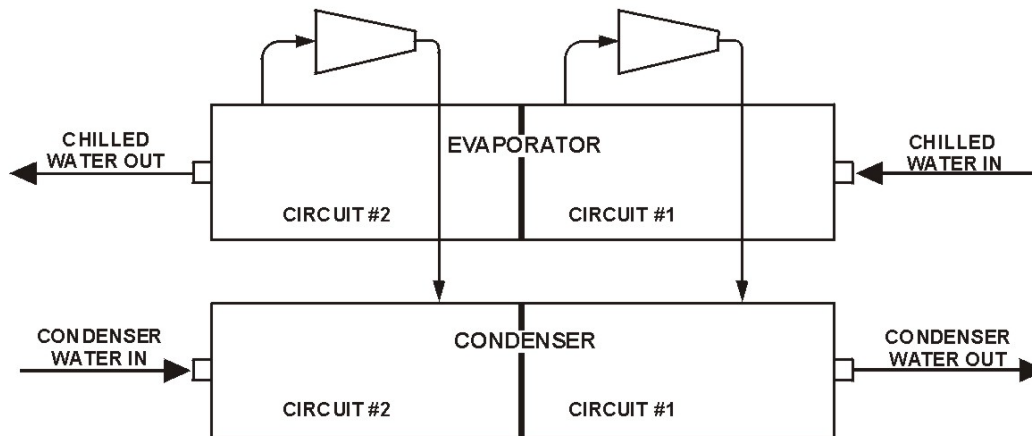

## Application of Dual Compressor Chillers

Designers and owners must decide which chiller type, or combination of chiller types, is best for their installation. Considerations include first cost, system efficiency, system reliability, space requirements, and total owning costs.

### Use WCT 3000 Dual Circuit chillers when:

- Project requirement is lowest kW per ton performance at full load with high electrical demand charges.
- Project has a large central plant where cycling chillers for system capacity reduction is expected (three or more chillers).
- High chilled water delta-T and low water pressure drops are desired.
- Built-in redundancy is required. A single compressor will provide 50% of the unit's full load capacity.
- High efficiency and large capacity to satisfy the cooling requirements of large district chilled water applications when installed in series-counter flow pairs to meet the high lift system requirements of the Middle-East market.

## Series Counter Flow Chillers

The design of a chiller plant can greatly impact chiller performance. A popular system is to place the evaporators in series with the chilled water flowing from one evaporator to the next as shown in Figure 2.

The system puts all of the condenser water through the condenser of the lag chiller (chiller producing the coldest evaporator leaving water) and then through the lead chiller (chiller seeing the warmest inlet evaporator water). This arrangement, utilizing two separate chillers, provides outstanding efficiency.

With counter flow arrangement the lift on each machine is significantly lower, reducing compressor work and improving the unit efficiency, especially at full load.

Even though the chiller operating conditions and performance are different, it is good practice to use the same chiller models.

The WCT 3000 chillers are suitable for series counter flow arrangement and include controls specifically designed for series chillers. For more information, please refer to McQuay Application guide AG -31-003: Chiller Plant Design.

**Figure 2, 6000 Ton System with Two Dual-Circuit WCT 3000 Counter Flow Chillers**

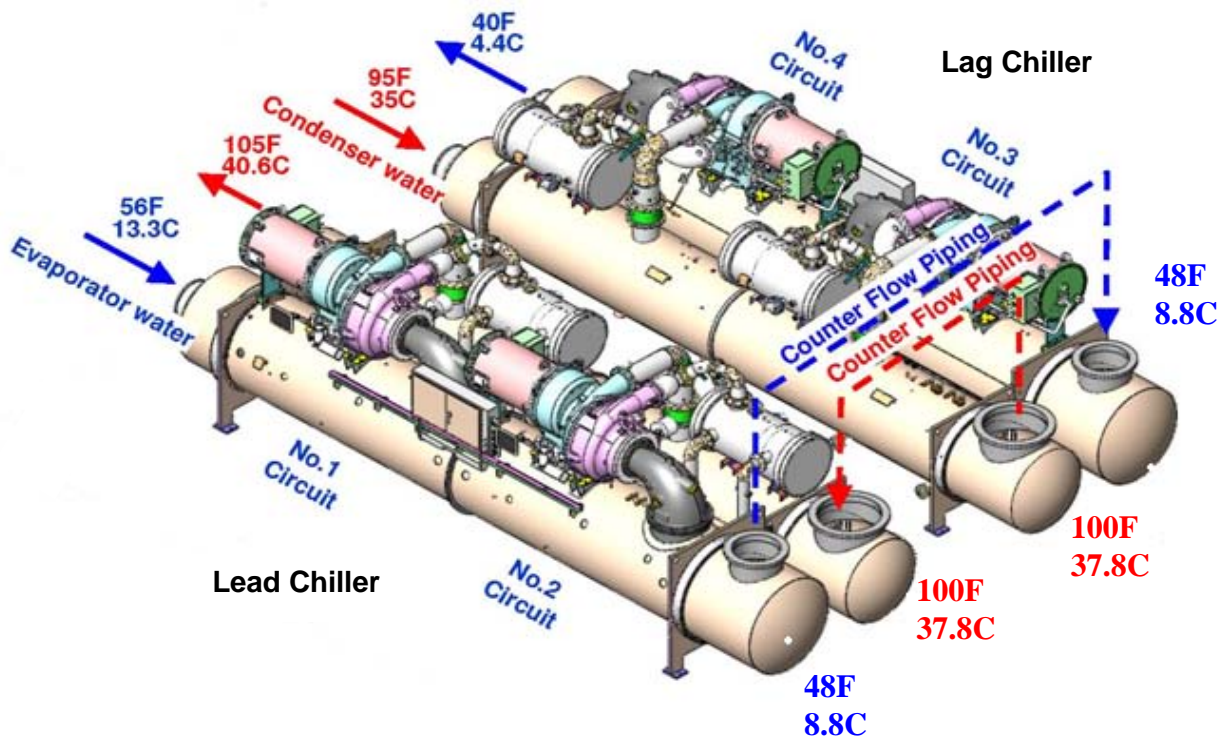

## Efficiency

WCT 3000 chillers, with their counter flow design, excel at full load efficiency. Each of the two compressors operates at a lower head (pressure differential) than single compressor chillers in parallel. With any pump or compressor, lower head means lower power for a given flow. As shown on Figure 1, the lag chiller makes 40°F (4.4°C) water but has only 100°F (37.8°C) condenser water leaving instead of 105°F (40.6°C) typical of a single compressor unit. The lead chiller has 105°F (40.6°C) condenser water leaving, but only has to make 48°F (8.9°C) chilled water.

## The Replacement Market Advantage

- Bolt-together construction on single and dual compressor chillers along with factory disassembly available as an option simplify the tough entrance situations.
- Put 20% or more tons in the same footprint.
- Add dual compressor redundancy.
- Greatly reduce chiller energy consumption.
- Install a refrigerant with no phase-out date.
- Opens many options for multiple chiller plants using WCT combinations.
- Reduction in the installation cost for a chiller plant.

# Unit Design Features

---

## Vessels

WCT 3000 chiller has a single evaporator and a condenser providing two internal refrigerant circuits for each of the two compressors and economizers on the chiller.

Single-pass water flows in evaporator and condenser are counter flow to each other.

Evaporator and condenser shells are fabricated from carbon steel, rolled shells with a welded longitudinal joint. Tube sheets and tube supports are made of carbon steel plates, drilled and reamed to remove any burrs for tube holes. Water connections are grooved, suitable for victaulic couplings as standard or flanged connections as an option. Epoxy coating is available as an option.

The standard condenser is a shell-and-tube heat exchanger. An integral sub-cooler at the bottom of the condenser provides subcooled refrigerant liquid and a discharge baffle at the top provides uniform vapor flow to enhance heat transfer and protects the tubes from gas impingement.

The standard evaporator is a flooded type shell-and-water tube heat exchanger. A refrigerant distributor at the bottom of the evaporator shell provides uniform distribution over the entire shell length for optimum heat transfer. A large integral drop-out area and a suction baffle at the top protects the compressor from damaging refrigerant carryover.

Each evaporator and condenser shell contains two separate refrigerant circuits. Each circuit is isolated from each other by a welded tube sheet in the middle of the vessel.

The refrigerant-side design pressure is 200 psi (1379 kPa) and water-side is 150 psi (1034 kPa) on all WCT evaporators and condensers.

Chillers are designed, constructed and tested in accordance with *ASME Boiler and Vessel Code*, Section VIII, Division I and ASHRAE Standard 15 requirements.

The economizer is a flash tank consisting of separation baffles for refrigerant vapor from liquid and mechanical float type expansion valves for liquid control. It is fabricated from steel pipe. There are two economizers for each chiller used per circuit.

## Expansion Valves

There are multiple refrigerant control devices used in the two-stage chillers.

The first expansion process is through the electronic expansion valve before the economizer, which is located in the piping between the condenser and economizer, and there are mechanical float type expansion valve(s) located in the economizer for the second expansion.

## Capacity Control System

The motor driven inlet guide vanes (IGV) located at the entrance to the compressor first stage impeller control the quantity of refrigerant entering the impeller, thereby controlling the compressor capacity in the first-stage. A motor-driven variable diffuser or discharge diffuser controls (DDC) in the second stage. Both the IGV and DDC motors are single-phase 220V motors.



## **Enhanced Surge Protection**

Enhanced Surge Protection (ESP) minimizes compressor stall/surge damage. When centrifugal compressors operate at part load, the volume of refrigerant gas entering the impeller is reduced. At the reduced flow, the impeller's capacity to develop the peak load head is also reduced. At conditions of low refrigerant flow and high compressor head (pressure difference), stall and/or surge can occur (a stall is gas static in the impeller; a surge condition is gas rapidly reversing direction through the impeller).

A number of things can contribute to this condition including inadequate maintenance of condenser tube cleanliness, a cooling tower or control malfunction, or unusual ambient temperatures, among others. For these abnormal conditions, McQuay International developed a protective control system that senses the potential for a surge, looks at the entire chiller system operation and takes corrective action if possible; or stops the compressor, to help prevent any damage from occurring. This protection, called "ESP" is provided as standard on all Daikin McQuay centrifugal compressors.

## **Lubrication System**

An internal oil sump contains a 750W submersible fixed-speed oil pump and a 1 kW immersion-type oil heater, which is thermostatically controlled. Oil is filtered by an externally mounted 10-micron replaceable cartridge oil filter and is cooled via a refrigerant-cooled plate type oil cooler. Both the oil lubrication piping and oil cooler refrigerant piping are completely factory-installed eliminating the need of any field cooling water and piping.

## **Oil Return Control Management System**

Two eductor circuits return migrated oil and refrigerant mixture from the refrigeration circuits to the oil sump for separation during the chiller operation even at low loads.

## **Water Flow Sensors**

Temperature-based, solid-state flow sensors are factory mounted in the evaporator and condenser inlet water nozzles and are factory wired to the control panel. They protect the chiller from operation at low or no flow conditions.

# Control Features

---

## **WCT 3000 Chillers Feature MicroTech III® Controls**

McQuay International has incorporated the latest microprocessor technology into the MicroTech III control system to give you the ultimate in chiller control. The control includes many energy-saving features to keep your chiller running efficiently - day in, day out, for years to come.

### ***Figure 3, Unit Control Panel and Operator Interface Touch Screen***

The unit controllers and other components are mounted in the unit control panel. The 15-inch color operator interface touch screen, (OITS) is mounted adjacent to the panel. It is on an adjustable arm so that it can be positioned comfortably for each operator. The control panel contains a USB port from which trend data can be conveniently downloaded. All-important unit operating data is easily accessed and viewed. Password protected unit setpoints, complete with description and setting range, are available at the touch of the screen.

If the interface touch screen is out of service, the chiller can continue to operate on the compressor and unit controllers. The touch screen is for information only and has no control function.

### ***Figure 4, Interface Touch Screen***

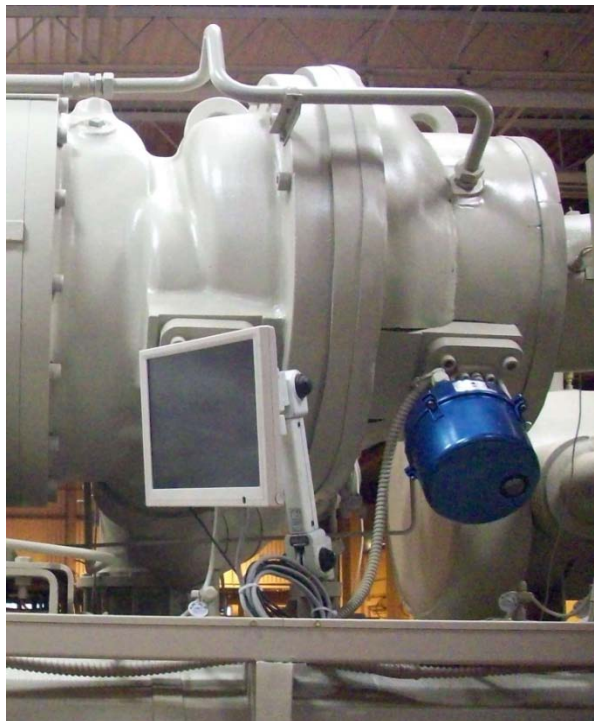

## MicroTech III Features and Benefits

FEATURE	BENEFIT
Open Choice™ Easy integration into a BAS via a factory or field-installed control module communicating with BACnet®, LONMARK® or Modbus® protocols.	The designer can select a BAS supplier using industry standard protocols and the Micro-Tech II control will easily interface with it.
Easy to read, adjustable, 15-inch, Super VGA color touch screen operator interface	Operators can observe chiller operation at a glance, easily select various detail screens and change setpoints.
Historic trend data-can be downloaded from an onboard USB port	Water temperatures, refrigerant pressures, and motor load plots can provide valuable unit operation data.
Proactive pre-shutdown correction of “unusual conditions” helps keep chiller online under off-standard conditions.	Activates alarm and modifies chiller operation to provide maximum possible cooling.
Automatic control of chilled water and condenser water pumps	Integrated lead/lag and automatic engagement of backup pump
Controls up to four stages of tower fans and modulation of tower fan and/or bypass valve	Optimum integrated control of cooling tower water based on system conditions.
Twenty-five previous alarm descriptions are stored in memory	Facilitates troubleshooting unit or system issues
Multiple language capability Metric or in-lb units of measure	Flexibility for world-wide applications

### Designed with the System Operator in Mind

Reliable, economic use of any chiller depends largely on an easy operator interface. That’s why operation simplicity was one of the main considerations in the development of the MicroTech III controller. The human-machine-interface (HMI) interface with the chiller is a 15-inch (381 mm), Super VGA color touch-screen. The operator can clearly see the entire chiller graphically displayed, with key operating parameters viewable on the screen. Other screens, such as alarm history and setpoints, are easily accessed through touch screen buttons. The alarm history can be viewed on the screen or can be downloaded to a computer through the onboard USB port.

The unit operating and maintenance manual is installed in the chiller’s microprocessor memory, so that it can be viewed on the touch screen or downloaded through the unit-mounted USB port.

### Proactive Control

By constantly monitoring chiller status, the MicroTech III controller will automatically take proactive measures to relieve abnormal conditions or shut the unit down if a fault occurs. For example, if a system problem occurs and suction pressure starts to drop, the controller will automatically hold the load point and activate an alarm signal. A further drop in pressure will initiate compressor unloading in an effort to maintain the setpoint pressure. If the pressure continues to drop, the unit will shut off at the unit safety setting.

### Alarm History for Easy Troubleshooting

The MicroTech III controller's memory retains a record of faults and a time/date stamp. The controller's memory (no batteries required) can retain and display the cause of the current fault and the last twenty-five fault conditions. This method for retaining the fault is extremely useful for troubleshooting and maintaining an accurate record of unit performance and history.

The MicroTech III controller features a three-level password security system to provide protection against unauthorized use.

**Figure 5, MicroTech II Controller Home Screen**

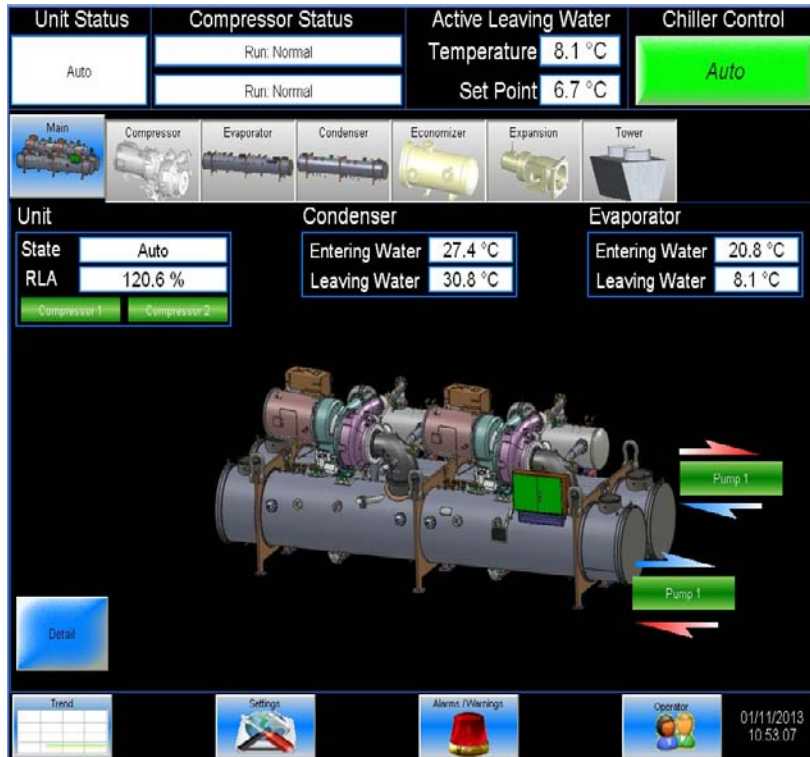

The Home Screen shown above is the primary viewing screen. It gives real time data on unit status, water temperatures, chilled water setpoint and motor amp draw. This display instantly answers the vital question-is the chiller doing what it is supposed to be doing?

If an alarm occurs, the alarms/warnings button will be animated (blinking) on the screen (a remote signal is also available). Pressing this button accesses the Active Alarm Screen that gives complete fault information. The fault can be corrected and cleared at this point.

### Changing Setpoints

Changing setpoints is easy with the MicroTech III control. For example, to change the chilled water setpoint, press SET button from any screen, then press WATER and this screen appears, now press Cool Leaving Water Temperature button, and you are ready to input a password and a new value.

**Figure 6, Set Point Screen**

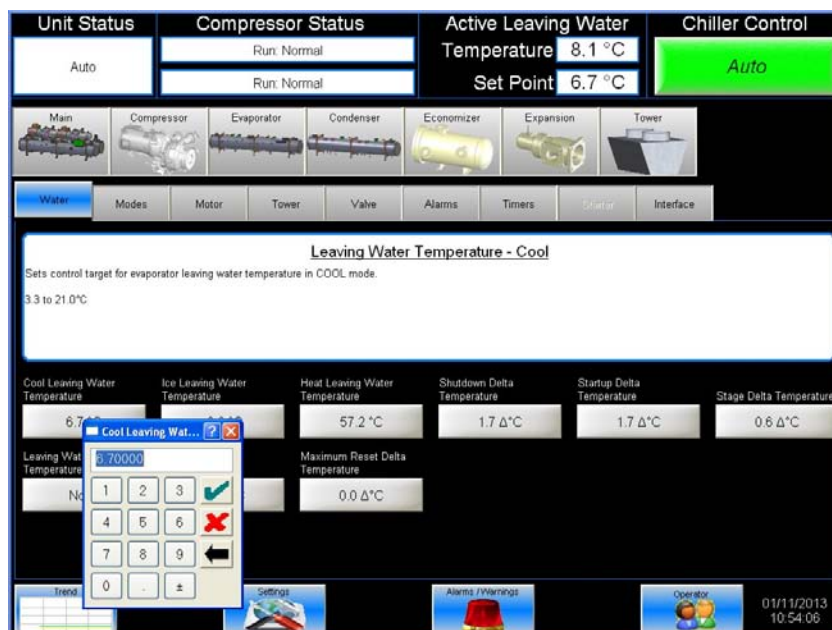

## Trend Logging

Knowledge of the chiller's recent performance can be useful for troubleshooting and energy management purposes.

The Daikin McQuay MicroTech III controller provides this information, thanks to its huge memory; by plotting water temperatures, refrigerant pressures, and motor load data. These values can also be downloaded through a convenient USB port, in the unit control panel, and pasted into a spreadsheet for detailed evaluation.

**Figure 7, Trend Logging Screen**

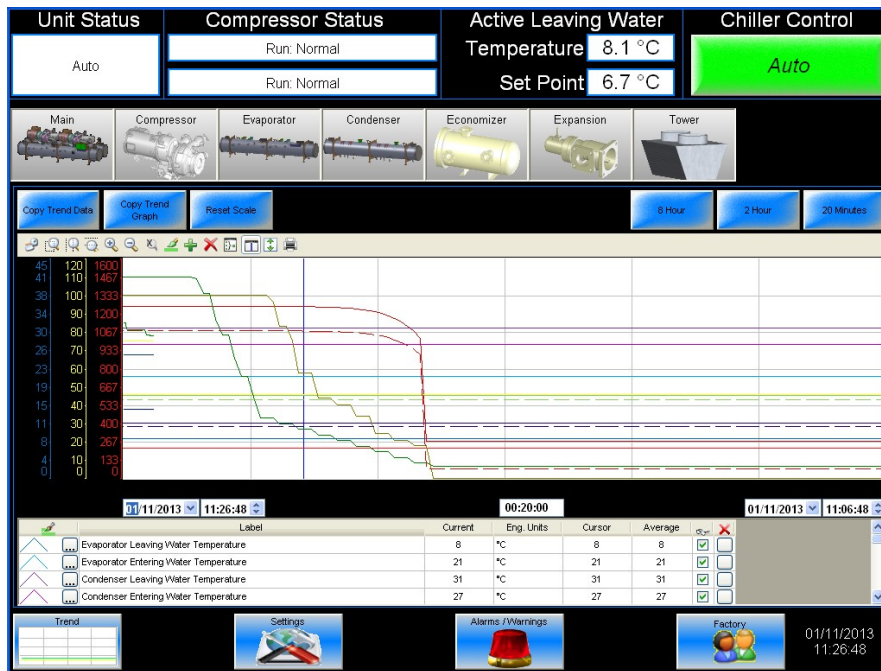

## MicroTech III Controller Increases Chiller Operating Economy

Many standard features have been incorporated into MicroTech III control in order to maintain the operating economy of Daikin McQuay centrifugal chillers. We've enhanced the controller's energy saving capabilities with the following features:

- **Direct control of water pumps.** Provides automatic lead-lag of the evaporator and condenser pumps, permitting pump operation only when required.
- **User-programmable compressor soft loading.** Prevents excessive power draw (demand) during pull down from high chilled water temperature conditions.
- **Chilled-water reset.** Accomplished directly on the unit by resetting the leaving water temperature based on the return water temperature, a remote 4-20 ma or a 1-5 VDC BAS signal. Raising the chilled water setpoint during periods of light loads dramatically reduces power consumption.
- **Demand limit control.** Maximum motor current draw can be set on the panel, or can be adjusted from a remote 4-20ma or 1-5 VDC BAS signal. This feature controls maximum demand charges during high usage periods.
- **Condenser water temperature control.** Capable of four stages of tower fan control, plus an optional analog control of either a three-way tower-bypass valve or variable speed tower-fan motor. Stages are controlled from condenser-water temperature. The three-way valve can be controlled to a different water temperature or track the current tower stage. This allows optimum chilled water plant performance based upon specific job requirements.
- **Staging Options (Multiple Chiller Installations).** The MicroTech III controller is capable of compressor staging decisions and balancing compressor loads between up to four WTC chillers using defaults or operator-defined staging.
- **Plotting Historic Trends.** Past operation of the chiller can be plotted as trend lines and downloaded to spread sheets for evaluation - a valuable tool for optimizing efficiency.

# Building Automation Systems

MicroTech III controller are capable of communications, providing seamless integration and comprehensive monitoring, control, and two-way data exchange with industry standard protocols such as LONMARK®, Modbus® or BACnet®.

## Open Choice™ Benefits

- Easy to integrate into your building automation system of choice
- Factory-installed and tested or field-installed communication modules
- Comprehensive point list for system integration, equipment monitoring and alarm notification
- Provides efficient equipment operation
- Owner/designer can select the BAS that best meets building requirements
- Comprehensive data exchange

## Integration Made Easy

Daikin McQuay unit controllers strictly conform to the interoperability guidelines of the LONMARK® Interoperability Association and the BACnet Manufacturers Association. They have received:

- LONMARK certification with the optional LONWORKS communication module

## Protocol Options

- BACnet MS/TP
- BACnet IP
- BACnet Ethernet
- LONWORKS® (FTT-10A)
- Modbus RTU

The BAS communication module can be ordered with a chiller and factory-mounted or can be field-installed at any time after the chiller unit is installed.

**Table 1, Typical Data Point Availability**

Typical Data Points <sup>1</sup> (W = Write, R = Read)					
Active Setpoint	R	Cond EWT	R	Evap Water Pump Status	R
Actual Capacity	R	Cond Flow Switch Status	R	Heat Recovery EWT	R
Capacity Limit Output	R	Cond LWT	R	Heat Recovery LWT	R
Capacity Limit Setpoint	W	Cond Pump Run Hours	R	Heat Setpoint	W
Chiller Enable	W	Cond Refrigerant Pressure	R <sup>2</sup>	Ice Setpoint	W
Chiller Limited	R	Cond Sat. Refrigerant Temp	R <sup>2</sup>	Liquid Line Refrigerant Pressure	
Chiller Local/Remote	R	Cond Water Pump Status	R	Liquid Line Refrigerant Temp	R
Chiller Mode Output	R	Cool Setpoint	W	Maximum Send Time	W
Chiller Mode Setpoint	W	Current Alarm	R	Minimum Send Time	W
Chiller On/Off	R	Default Values	W	Network Clear Alarm	W
Chiller Status	R	Evap EWT	R	Oil Feed Pressure	R
Compressor Discharge Temp	R	Evap Flow Switch Status	R	Oil Feed Temp	R
Compressor Percent RLA	R	Evap LWT for Unit	R	Oil Sump Pressure	R
Compressor Run Hours	R	Evap LWT for Compressor	R	Oil Sump Temp	R
Compressor Select	W	Evap Pump Run Hours	R	Outdoor Air Temp	
Compressor Starts	R	Evap Refrigerant Pressure	R2	Pump Select	W
Compressor Suction Line Temp	R	Evap Sat. Refrigerant Temp	R2	Run Enabled	R

**Figure 8, Sample System Architecture**

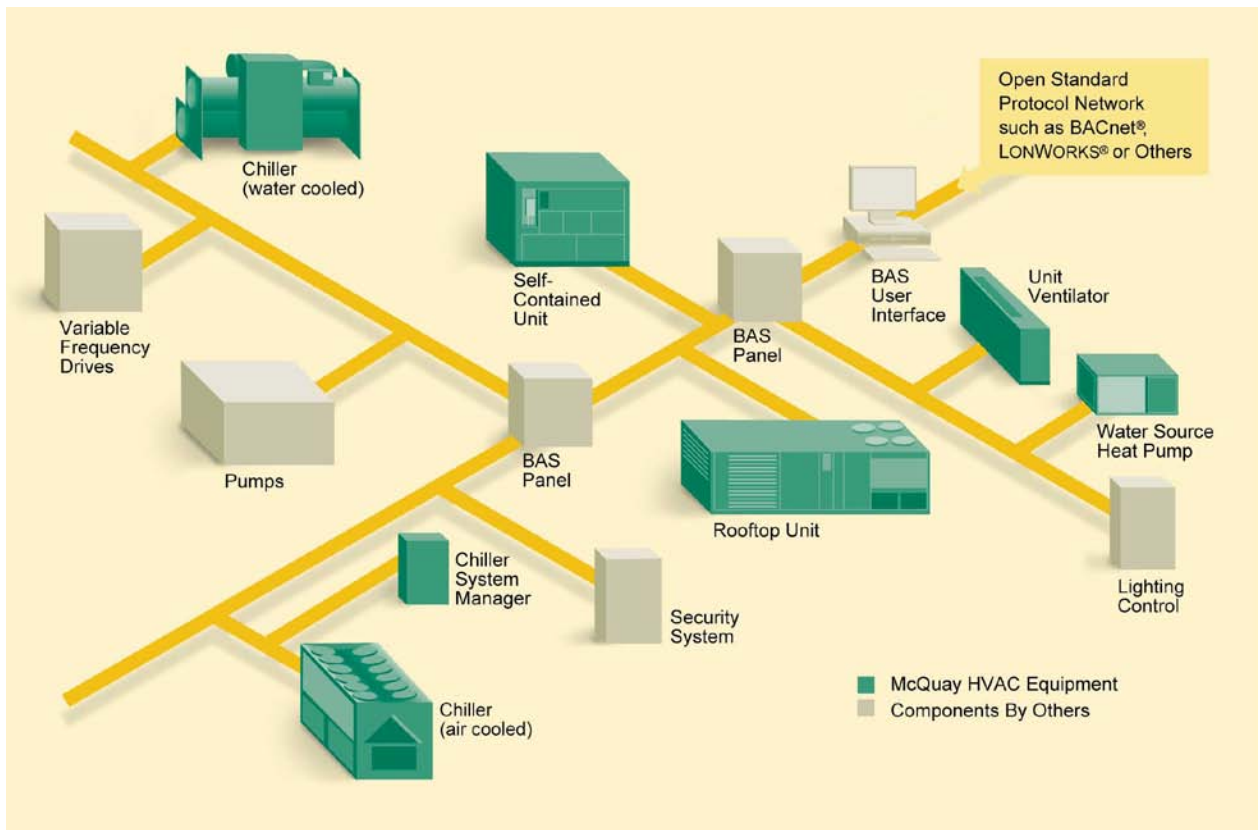



# Retrofit Disassembly

It is estimated that fifty percent of retrofit applications require partial or complete disassembly of the chiller. Daikin McQuay WCT 3000 chillers are designed to facilitate disassembly and reassembly at the job site.

**Type 1**, the compressor and compressor control box are removed and put on a skid. All associated wiring and piping will remain attached if possible. The remaining loose parts will be packaged in a separate crate.

**Type 2**, compressor and terminal box are removed and put on a skid. The condenser, evaporator, and oil pump and supports will remain connected only by the attachment bolts for easy disassembly at the job site or riggers. All wiring and piping that interconnects the components will be removed. The remaining loose parts will be packaged in a separate crate.

**Table 2, Type I Knockdown Dimensions**

SHELLS	COMP	UNIT WIDTH in (mm)	UNIT HEIGHT in (mm)
E5426/C5426	K		

**Table 3, Type II Knockdown Dimensions**

SHELLS	COMPRESSOR	EVAPORATOR		CONDENSER	
		WIDTH in (mm)	HEIGHT in (mm)	WIDTH in (mm)	HEIGHT in (mm)
E5426/C5426	K				

**Notes:**

1. Vessel length is approximately 175-inches, (4444 mm).
2. The overall vessel length can vary depending on the specified tube length and pass arrangement. Consult the Daikin McQuay certified submittal drawings, or unit dimensions beginning on page 24 in this catalog for specific vessel lengths.
3. Allow plus / minus 1 inch (24.5 mm) for factory manufacturing tolerance.

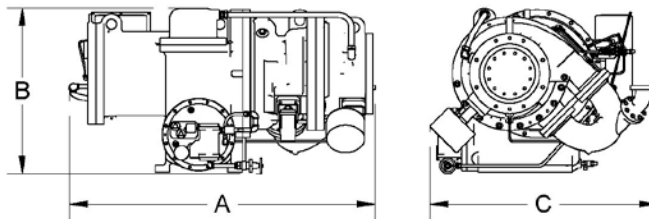

**COMPRESSOR**

Compressor Code	DIM. 'A'	DIM. 'B'	DIM. 'C'
<b>K</b>	108.8 (2763)	50.9 (1293)	80.5 (2043)

**Note :**

The dimensions might vary for different voltages



# Options and Accessories

---

## Vessels

GB and PED designed heat exchangers.

### Marine water boxes

Provides tube access for inspection, cleaning, and removal without dismantling water piping.

### Flanges (Victaulic® connections are standard)

ANSI raised face flanges on either the evaporator or condenser. Mating flanges are by others.

### 0.028 or 0.035 in. tube wall thickness

For applications with aggressive water conditions requiring thicker tube walls.

### Copper-nickel or titanium tube material

For use with corrosive water conditions, includes clad tube sheets and epoxy or ceramic coated water heads.

### Water differential pressure switches

This option provides evaporator and condenser water pressure differential switches as a factory mounted and wired option. A proof-of-flow device is mandatory in both the chilled water and condenser water systems.

### Single insulation, ¾-inch, on evaporator, suction piping, and motor barrel

For normal machine room applications.

### Double insulation, 1-½ inch, on evaporator, suction piping, and motor barrel

For high humidity locations and ice making applications

## Electrical

**Field mounted Starters** are available upon request.

**NEMA 12 Dust tight enclosure** For use in dusty areas.

## Unit

### Export packaging

All size units can be skidded, framed and hear shrink wrapped and shipped on a flat rack

**Extended warranties:** Local Decision.

### Knockdown Options

Reduces unit size for tight rigging situations.

## Factory Performance Test

---

All Daikin McQuay chillers are factory tested on AHRI certified, microprocessor controlled, test stands. The test stand microprocessors interface with the chiller MicroTech II controls, allowing monitoring of all aspects of the test stand and chiller operation.

The test procedure starts with dehydration and evacuation of the refrigerant circuit and charging with refrigerant and lubricant. This is followed by a functional run test to check control settings and operation and general unit operation. Compressors must meet a stringent 0.14 in/sec vibration limit and the entire unit must pass a moisture limit of 30 ppm. The testing helps ensure correct operation prior to shipment, and allow factory calibration of chiller operating controls.

### **Optional Certified Test**

A Daikin McQuay engineer oversees the testing, certifies the accuracy of the computerized results, and then translates the test data onto an easy-to-read spreadsheet. The tests can be run at AHRI load points and are run to AHRI tolerance of capacity and power.

### **Optional Witness Test**

A Daikin McQuay engineer oversees the testing in the presence of the customer or their designate and translates the test data onto an easy-to-read spreadsheet. The tests can be run at AHRI load points and are run to AHRI tolerance of capacity and power.

## AHRI Standard 575 Sound Ratings

---

Sound data in accordance with AHRI Standard 575 for individual units are available from your local McQuay representative. Due to the large number of component combinations and variety of applications, sound data is not included in this catalog.

# Application Considerations

## Location

These units are intended only for installation in an indoor or weather protected area consistent with the NEMA 1 rating on the chiller, controls, and electrical panels.

Equipment room temperature for operating and standby conditions is 40°F to 104°F (4.4°C to 40°C).

## Optimum Water Temperatures and Flow Rates

A key to improving energy efficiency for any chiller is minimizing the lift, or pressure difference, between the compressor suction and discharge pressures. Reducing the lift reduces the compressor work, and hence its energy consumption per unit of output. The chiller typically has the largest motor of any component in a chilled water system.

### Higher leaving chilled water temperatures

Warmer leaving chilled water temperatures will raise the compressor's suction pressure and decrease the lift, improving efficiency. Using 45°F (7.0°C) leaving water instead of 42°F (5.5°C) will make a significant improvement.

### Evaporator temperature range

The industry standard has been a ten-degree temperature drop in the evaporator. Increasing the drop to 12 or 14 degrees F (6.6 or 7.7 degrees C) will improve the evaporator heat transfer, raise the suction pressure, and improve chiller efficiency. Chilled water pump energy will also be reduced.

### Condenser entering water temperature

As a general rule, a one-degree drop in condenser entering water temperature will reduce chiller energy consumption by two percent. Cooler water lowers the condensing pressure and reduces compressor work. One or two degrees can make a noticeable difference. The incremental cost of a larger tower can be small and provide a good return on investment.

### Condenser water temperature range

The industry standard of 3 gpm/ton or about a 9.5-degree F (5.2 degrees C) delta-T seems to work well for most applications. Reducing condenser water flow to lower pumping energy will increase the water temperature rise, resulting in an increase in the compressor's condensing pressure and energy consumption. This is usually not a productive strategy.

## System analysis

Although Daikin McQuay is a proponent of analyzing the entire system, it is generally effective to place the chiller in the most efficient mode because it is, by far, a larger energy consumer than pumps.

The McQuay Energy Analyzer™ program is an excellent tool to investigate the entire system efficiency, quickly and accurately. It is especially good at comparing different system types and operating parameters. Contact your local Daikin McQuay sales office for assistance on your particular application.

### For Best Chiller Efficiency

Vessel	Activity	Example
Evaporator	Higher leaving water Temperatures	44 °F (6.7°C) Instead Of 42 °F (5.6°C)
Evaporator	Higher water temperature drops	12 instead of 10 degrees F (6.6 instead of 5.5 degrees C)
Evaporator	Lower flow rates	2.4 gpm/ton instead of 3.0 gpm/ton
Condenser	Lower entering water temperature	84°F (28.9°C) instead of 85 °F (29.4°C)
Condenser	Higher flow rates (3.0 gpm/ton or higher)	3.0 gpm/ton instead of 2.5 gpm/ton

The designer must determine the proper chiller efficiency for a given application. The most efficient chiller is not always the best. A life cycle analysis (as performed by McQuay's Energy Analyzer program, for example) is the only way to be sure of the best selection. Utility costs, load factors, maintenance costs, cost of capital, tax bracket; in other words, all the factors affecting owning cost, must be considered.

## Pumps

Model WCT 3000 chiller compressor motors operate at 3540 rpm on 60 Hz power (2950 rpm on 50 Hz). To avoid the possibility of objectionable harmonics in the system piping, 4-pole, 1800/1500 rpm system pumps should be used. The condenser water pump(s) must be cycled off when the last chiller of the system cycles off. This will keep cold condenser water from migrating refrigerant to the condenser. Cold liquid refrigerant in the condenser can make start-up difficult. In addition, turning off the condenser water pump(s) when the chillers are not operating will conserve energy.

## Piping

Piping must be adequately supported to remove weight and strain on the chiller's fittings and connections. Be sure piping is adequately insulated. All water piping should be thoroughly cleaned of all dirt and debris before they are connected to the chiller. Install a cleanable 20-mesh water strainer upstream of the evaporator and condenser as close as possible to the chiller to retain any possible dirt/debris coming from the cooling tower or deterioration of piping or from water source entering the chiller tubes resulting a reduction of flow and in return impairment of chiller performance or freezing tubes.

Install enough shutoff valves to permit draining water from the evaporator or condenser without draining the complete system.

### CAUTION

Freeze Notice: The evaporator and condenser are not self-draining. Both must be blown out to completely remove water to help prevent residual water from freezing.

Include thermometers and pressure gauges at the chiller inlet and outlet connections and air vents at the high points of piping. When water pump noise is objectionable, use rubber isolation sections at both the inlet and outlet of the pump. Vibration eliminator sections in the condenser inlet and outlet water lines are not normally required.

All evaporators and condensers have Victaulic ANSI/AWWA C-606 couplings as standard with flange connections as option. The companion flanges, bolts, nuts and gaskets are not included and the installing contractor must provide matching mechanical connections or transitions of the size and type required.

## Filtering and Treatment

Owners and operators must be aware that if the unit is operating with a cooling tower, cleaning and flushing the cooling tower is required. Make sure tower blow-down or bleed-off is operating. Atmospheric air contains many contaminants, which increases the need for water treatment. The use of untreated water will result in corrosion, erosion, slime buildup, scaling, or algae formation which will degrade chiller performance and increase operating and maintenance costs. A water treatment service should be used. Daikin McQuay International is not responsible for damage or faulty operation from untreated or improperly treated water.

## Machine Room Ventilation

The ASHRAE Standard 15 requires refrigerant detector(s) in case of a refrigerant leak and mechanical ventilation to the outdoors in machine rooms. In addition to this standard, National Fire Protection Association Standard 90A, state, local and any other related codes should be consulted for specific requirements

Since Two-Stage chiller motor is refrigerant cooled, the motor heat is not rejected into the ambient air in the equipment room and therefore WCT chillers DO NOT require additional ventilation.

## Vibration Mounting

Every Daikin McQuay chiller is run tested and compressor vibration is measured and limited to a maximum rate of 0.14 inches per second (3.56 mm/s), which is considerably more stringent than other available compressors. Neoprene vibration pads are shipped with each unit. It is wise to continue to use piping flexible connectors to reduce sound transmitted into the pipe and to allow for expansion and contraction.

## System Water Volume

All chilled water systems need adequate time to recognize a load change, respond to that load change and stabilize, without undesirable short cycling of the compressors or loss of control. In air conditioning systems, the potential for short cycling usually exists when the building load falls below the minimum chiller plant capacity or on close-coupled systems with very small water volumes or due to improperly operating system controls.

Some of the things the designer should consider when looking at water volume are the minimum cooling load, the minimum chiller plant capacity during the low load period and the desired cycle time for the compressors.

Assuming that there are no sudden load changes and that the chiller plant has reasonable turndown, a rule of thumb of “gallons of water volume equal to two to three times the chilled water gpm flow rate” is often used.

A properly designed storage tank should be added if the system components do not provide sufficient water volume.

## Relief Valves

As a safety precaution and to meet ASME or applicable pressure vessel code requirements, each chiller is equipped with spring-loaded pressure relief valves in accordance with ANSI/ASHRAE Standard 15 safety code for the purpose of relieving excessive refrigerant pressure (caused by equipment malfunction, fire, etc.) as noted on the pressure vessel name plate. The relief valve should be replaced with a new one whenever such a release occurs.

## Pumpdown

To facilitate unit service, All Daikin McQuay centrifugal chillers are designed for pumpdown and isolation of the entire refrigerant charge in the condenser. A factory-installed check valve in the compressor line to the condenser and a ball valve in the condenser refrigerant outlet liquid line allow isolation and storage of the refrigerant charge in the condenser when servicing the compressor, economizer, and/or evaporator. This feature eliminates extra labor, time and the usage of remote storage vessels. Any tubing lines connected to the condenser should also be isolated by closing off the factory provided service angle valves before the pumpdown.

## Standby Power

It is essential that any centrifugal chiller connected to standby power come to a complete stop on grid power and then be restarted with the standby power. Attempting to switch from regular grid line power to auxiliary power while the compressor is running can result in extreme transient torque that will severely damage the compressor.

## Thermal Insulation

The insulation of cold surfaces to prevent condensation includes the evaporator, economizer, evaporator water head and nozzles, suction piping, motor housing, refrigerant supply and return oil cooler, economizer gas line, expansion valve and piping between economizer and evaporator and motor drain line.

Factory installed single and double insulation is optional.

Insulation is UL recognized (File # E55475). It is 3/4" thick ABS/PVC flexible foam with a skin. The K factor is 0.28 at 75°F. Sheet insulation is fitted and cemented in place forming a vapor barrier, then painted with a resilient finish that resists cracking.

The insulation complies to, or has been tested in accordance, with the following:

ASTM-C-177	ASTM-C-534 Type 2	UL 94-5V
ASTM-D-1056-91-2C1	ASTM E 84	MEA 186-86-M Vol. N
CAN/ULC S102-M88		

In the event insulation is to be field-installed, none of the cold surfaces identified above will be factory insulated. Approximate total square footage of insulation surface required for individual packaged chillers is tabulated by evaporator code and can be found below.

Evaporator E5426 requires XXX sq. ft. YYY(m<sup>2</sup>) including heads.

# Electrical Data

## Wiring and Conduit

Wire sizes must comply with local and state electrical codes. Where total amperes require larger conductors than a single conduit would permit, limited by dimensions of motor terminal box, two or more conduits can be used. Where multiple conduits are used, all three phases must be balanced in each conduit. Failure to balance each conduit will result in excessive heating of the conductors and unbalanced voltage.

An interposing relay can be required on remote mounted starter applications when the length of the conductors run between the chiller and starter is excessive.

Use only flexible/multistrand copper supply wires with ampacity based on 75°C conductor rating. (Exception: for equipment rated over 2000 volts, 90°C or 105°C rated conductors shall be used).

**Figure 9, Typical Field Connection Diagram per Circuit / Compressor**

**SCHEM. G00007009 REV.00**  
FIELD CONNECTION DIAGRAM  
CENTRIFUGAL UNITS

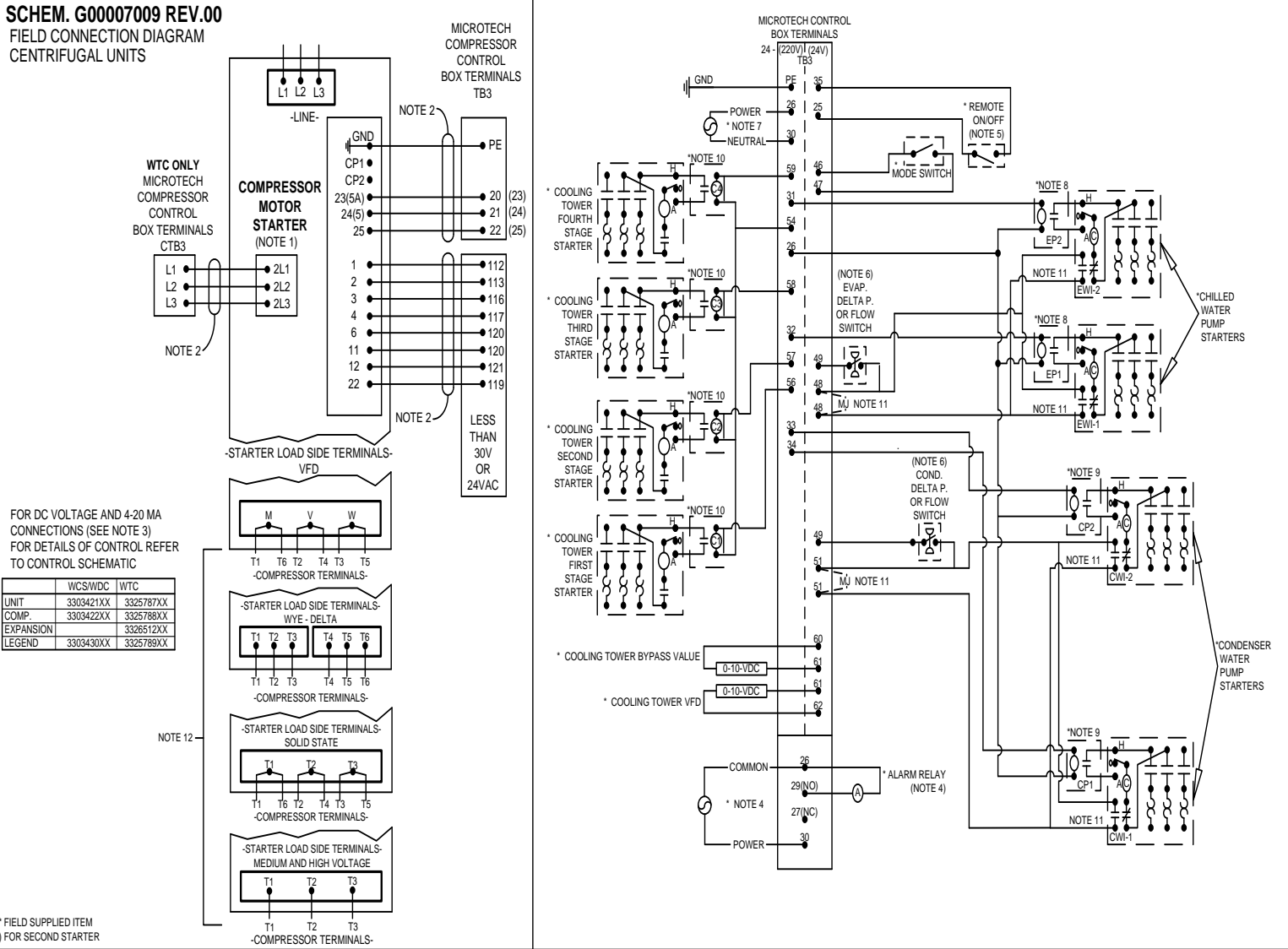

## Wiring Diagram Notes

1. Compressor motor starters are either factory mounted and wired or shipped separate for field mounting and wiring. If provided by others starters must comply with Daikin McQuay specification 359A999. All line and load side power conductors must be copper, with ampacity based on 75°C conductor rating. (Exception: for equipment rated over 2000 volts, 90°C or 105°C rated conductors shall be used.
2. Field control wiring between the starter and the control panel is required with free-standing starters. Minimum wire size for 115 VAC to 200 VAC is 12 GA. for a maximum length of 50 feet. If greater than 50 feet refer to Daikin McQuay for recommended wire size minimum. Wire size for 24 VAC is 18 GA. All wiring to be installed as NEC class 1 wiring system. All 20 VAC wiring must be run in separate conduit from 115 VAC and 200 VAC wiring. Main power wiring between starter and motor terminal is factory installed when units are supplied with unit mounted starters. Wiring of free standing starter must be wired in accordance with NEC and connection to compressor motor terminals must be made with copper wire and copper lugs only.
3. For optional sensor wiring see unit control diagram. It is recommended that DC wires be run separately from 115 VAC to 220 VAC wiring.
4. A customer furnished 24 or 120 VAC power for alarm relay coil may be connected between TB3 terminals 30 power and 26 neutral of the control panel. For normally open contacts wire between 24 and 26, for normally closed wire between 24 and 26. The alarm is operator programmable. Maximum rating of the alarm relay coil is 25 VA.
5. Remote on/off control of unit can be accomplished by installing dry contacts between terminals 70 and 54.
6. Evaporator and condenser flow switches are required. Factory mounted flow switches are standard on WCT units. Field installed flow switches must be wired as shown. If field supplied pressure differential switches are used then these must be installed across the vessel and not the pump. Paddle flow switches may also be field installed if desired.
7. Customer supplied 24 to 230 VAC 20 amp power for optional evaporator and condenser water pump control power and tower fans is supplied to unit control terminals (TB3) 26 power / 30 neutral, PE equipment ground.
8. Optional customer supplied 115 VAC 25 VA maximum coil rated chilled water pump relay (EP 1 and 2) may be wired as shown. This optional will cycle the chilled water pump in response to chiller demand.
9. The condenser water pump must cycle with the unit. A customer supplied 24-220 VAC 25 VA maximum coil rated condenser water pump relay (CP 1 and 2) is to be wired as shown.
10. Optional customer supplied 24-220 VAC 25 VA maximum coil rated cooling tower fan relays (C1 – C2 standard, C3 – C4 optional) may be wired as shown. This option will cycle the cooling tower fans in order to maintain unit head pressure.
11. Auxiliary 24 VAC rated contacts in both the chilled water and condenser water pump starters should be wired as shown and remove MJ.
12. For VFD, Wye-Delta, and solid state starters connected to six (6) terminal motors. The conductors between the starter and motor carry phase current and selection shall be based on 58 percent of the motor rated load amperes (RLA). Wiring of free standing starter must be in accordance with the NEC and connection to the compressor motor terminals shall be made with copper wire and copper lugs only. Main power wiring between the starter and motor terminals is factory installed when chillers are supplied with unit-mounted starters.

## Control Power

The control circuit on the Daikin McQuay centrifugal packaged chiller requires both 200Vac 3-phase and 115Vac 1-phase. Control power can be supplied from two different sources:

1. A freestanding starter or VFD furnished by Daikin McQuay, or the customer to Daikin McQuay specifications, will have a control transformer in it requiring field wiring to terminals in the control box.
2. Power can be supplied from separate circuits and fused at 20 amps inductive load. The control circuit disconnect switch must be tagged to prevent current interruption. Other than for service work, the switch is to remain on at all times in order to keep oil heaters operative and prevent refrigerant from diluting in oil.

### ⚠ DANGER

If a separate control power source is used, the following must be done to avoid severe personal injury or death from electrical shock:  
Place a notice on the unit that multiple power sources are connected to the unit.  
Place a notice on the main and control power disconnects that additional sources of power to the unit exist

In the event a transformer supplies control voltage, it must be rated at 3 KVA, with an inrush rating of 12 KVA minimum at 80% power factor and 95% secondary voltage. For control wire sizing, refer to NEC Articles 215 and 310. In the absence of complete information to permit calculations, the voltage drop should be physically measured.

**Table 4, Control Power Line Sizing**

MAXIMUM LENGTH, ft (m)	WIRE SIZE (AWG)	MAXIMUM LENGTH, ft (m)	WIRE SIZE (AWG)
0 (0) to 50 (15.2)	12	120 (36.6) to 200 (61.0)	6
50 (15.2) to 75 (22.9)	10	200 (61.0) to 275 (83.8)	4
75 (22.9) to 120 (36.6)	8	275 (83.8) to 350 (106.7)	3

**Notes:**

1. Maximum length is the distance a conductor will traverse between the control power source and the unit control panel.
2. Panel terminal connectors will accommodate up to number 10 AWG wire. Larger conductors will require an intermediate junction box.

The Unit On/Off switch located in the Unit Control Panel should be turned to the "Off" position any time compressor operation is not desired.

## Weights

**Table 5, Approximate Weights**

SHELLS	COMP	MAX. OPERATING WEIGHT lb. (kg)	MAX. SHIPPING WEIGHT lb. (kg)	EST. MAX. REFRIGERANT CHARGE lb. (kg)
E5426/C5426	K	115,287 (52,293)	ITALY will Determine	10,580 (4,800)

**Notes:**

1. Request a certified drawing for exact dimensions, charge, and weight.



# Dimensions

Figure 10, Unit Overall Dimensions

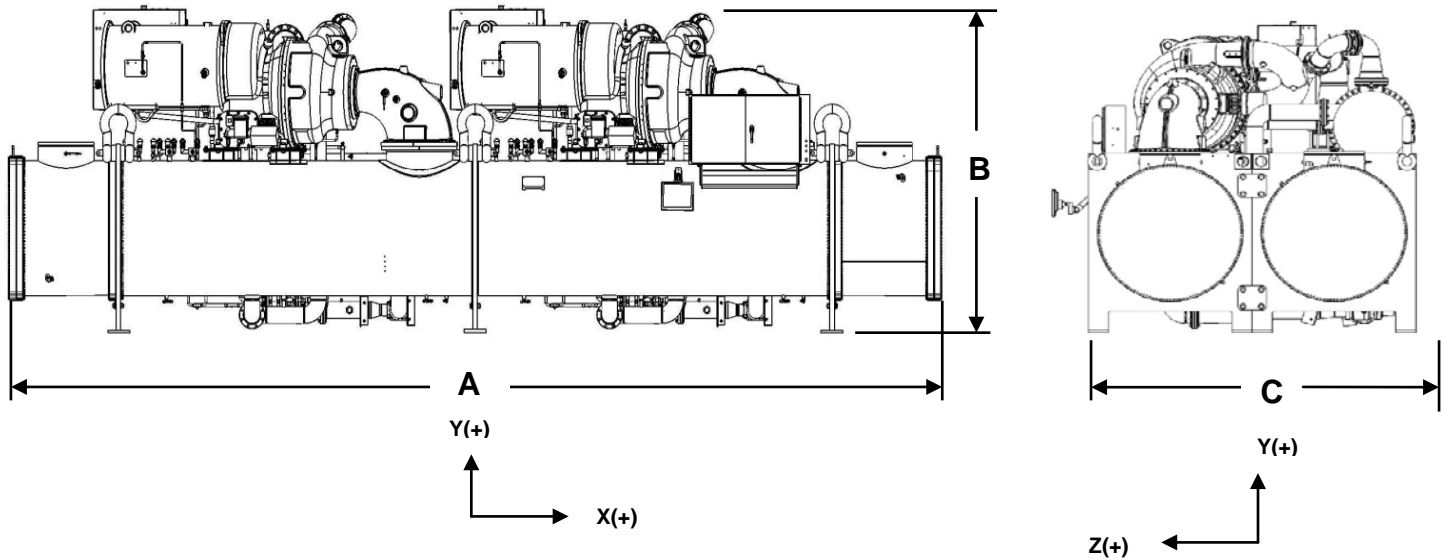
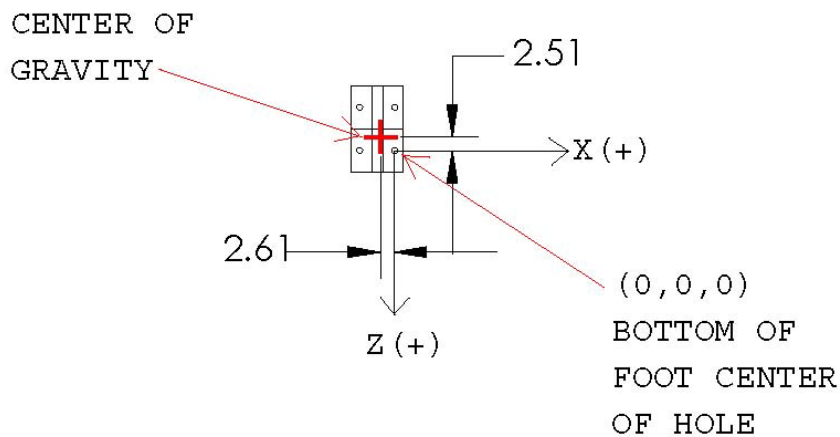
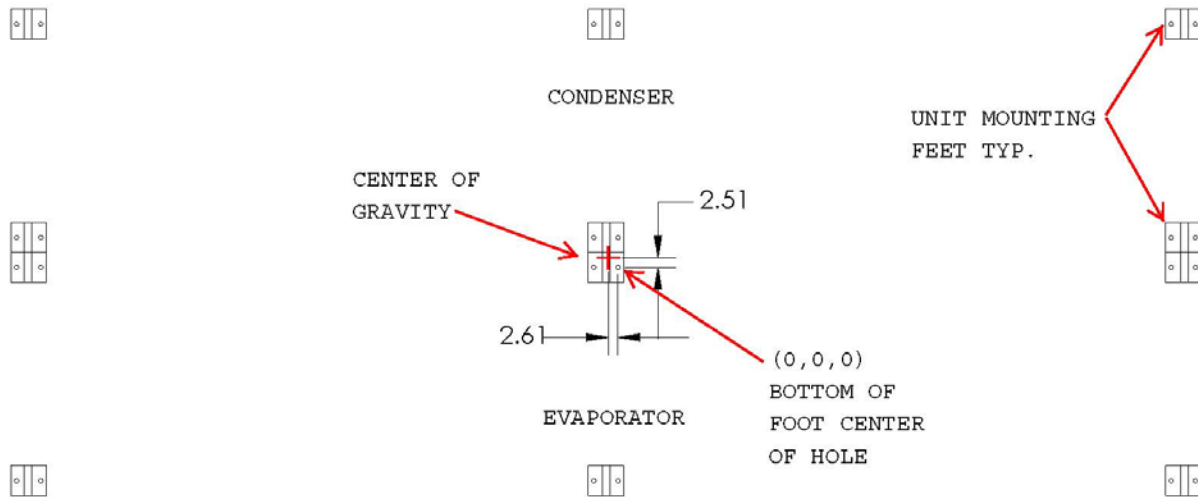

Figure 11, Unit Mounting Feet, Top Sectional View



**Table 6, Dimensions, Inches (mm)**

Nominal Tonnage	COMPR. MODEL	EVAP. MODEL	COND. MODEL	A' OVERALL LENGTH	B' OVERALL HEIGHT	C' OVERALL WIDTH	COG (OPERATING)			1 PASS EVAP. NOM. PIPE SIZE	1 PASS COND. NOM. PIPE SIZE
							X	Y	Z		
2500 -3000	K	E5426	C5426	395 (10033)	128 (3251)	130 (3300)	-2.6 (-66)	61.9 (1572)	-2.5 (-63.5)	24 (609.6)	24 (609.6)

**NOTES:**

1. Drawings included in this section are for rough layout purposes only. Detailed certified drawings, as .pdf or .dxf files, are available from the local McQuay sales office. Do not use catalog drawings for final construction.
2. Obtain specific unit certified drawings for detailed dimensions of water, and relief valve connections.
3. Allow three feet of service access on all four sides, plus allow the length of the tubes, plus two feet on one end, for tube removal. The last two numbers in the vessel code are the tube length in feet. The NEC or local code may require more than 3 feet clearance in front of control panels or starting equipment depending on voltage and layout.
4. The adjustable control interface panel is shipped un-mounted from the unit. When mounted, it can be folded back within the confines of the unit width and height and still be viewable.
5. A 1-inch manufacturing tolerance must be accounted for in the design and installation process.
6. To determine overall operating height, add the dimension in Table 5 for the appropriate isolator.
7. The shipping skid when used adds 4.00 inches [105 mm] to the overall unit height.
8. If main power wiring is brought up through the floor, this wiring must be outside the envelope of the unit.
9. The unit control panel/touch screen side is the "FRONT" of the unit. "RIGHT" and "LEFT" are determined looking at the front.
10. Neoprene pad isolators (with deflection) add an average of 0.375 in (9.5 mm) to height.
11. Tonnage Range is based on 100% Capacity per JIS B 8621 Rating Standard Conditions

# Supplemental Publications

---

Daikin McQuay has a large number of publications and software applications relating to centrifugal chillers and to chilled water systems. The latest versions are available on [www.daikinmcquay.com](http://www.daikinmcquay.com) or from the local McQuay sales office. Some of the available material is listed below:

## Application Guides

- *AG 31-002*, Centrifugal Chiller Fundamentals, a 20 page general guide, discussing compressor theory, vessel design and pass optimization, capacity control, prime movers and dual compressor chillers.
- *AG 31-003*, Chiller Plant Design, a 94 page comprehensive guide on designing chilled water plants. Some of the subjects included are water temperatures and ranges, parallel versus series flow, primary/secondary systems, free cooling, heat recovery.
- *AG 31-007* Refrigerant Application Guide, discusses refrigerant chemistry, specific refrigerant characteristics, phase-outs, substitutes, and what the future holds.

## Application Bulletins

- Application Bulletin, Issue No 4, Overview of ASHRAE Standard 90.1-1999, summarizes HVAC equipment efficiency requirements.

## MicroTech II Controls

- *A/SP 31-187*, McQuay Chiller System Manager (CSM), contains a description of the CSM panel used for control of up to twelve chillers in a chilled water plant.
- *IM 735*, installation manual for LONWORKS communication module on chillers.
- *IM 736*, installation manual for BACnet communication module on chillers.
- *IM 743*, installation manual for Modbus communication module on chillers.

## Software

- Energy Analyzer™, gives fast answers, with life cycle analysis, for optimizing chiller plant type and terminal equipment.
- Acoustic Analyzer™, with known equipment sound levels, this program will provide sound levels at various distances, with various wall configurations, giving total site results.

# Specifications

---

## SECTION 15XXX CENTRIFUGAL COUNTER-FLOW CHILLERS TWO-STAGE COMPRESSORS

### PART 1 — GENERAL

#### 1.1 SUMMARY

Section includes design, performance criteria, refrigerants, controls, and installation requirements for **two-stage** water-cooled centrifugal chillers.

#### 1.2 REFERENCES

Comply with the following codes and standards

▲HRI 550/590

ANSI/ASHRAE 15

ASME Section VIII Division I.

OSHA as adopted by the State

NEC

KHK

#### 1.3 SUBMITTALS

Submittals shall include the following:

- A. Dimensioned plan and elevation view drawings, including required clearances, and location of all field piping and electrical connections.
- B. Summaries of all auxiliary utility requirements such as: electricity, water, air, etc. Summary shall indicate quality and quantity of each required utility.
- C. Diagram of control system indicating points for field interface and field connection. Diagram shall fully depict field and factory wiring.
- D. Manufacturer's certified performance data at full load plus IPLV or NPLV.
- E. Installation, Operating and Maintenance Manuals.

#### 1.4 QUALITY ASSURANCE

- A. Qualifications: Equipment manufacturer must specialize in the manufacture of the products specified and have five years experience with the equipment and refrigerant offered.
- B. Regulatory Requirements: Comply with the codes and standards in Section 1.2.
- C. Chiller manufacturer plant shall be ISO Registered.

#### 1.5 DELIVERY AND HANDLING

- A. Chillers shall be delivered to the job site completely assembled and charged with helium.
- B. Comply with the manufacturer's instructions for rigging and transporting units. Leave protective covers in place until installation.

#### 1.6 WARRANTY

The refrigeration equipment manufacturer's warranty shall be for a period of (one) -- **OR** -- (two) --**OR**-- (five) years from date of equipment start up or 18 months from shipment whichever occurs first. The warranty shall include parts and labor costs for the repair or replacement of defects in material or workmanship.

#### 1.7 MAINTENANCE

Chiller maintenance shall be the responsibility of the owner with the following exceptions:

- A. The manufacturer shall provide the first year scheduled oil and filter change if required.

**PART 2 — PRODUCTS**

2.1 ACCEPTABLE MANUFACTURERS

- A. Daikin McQuay
- B. (Approved Equal)

2.2 UNIT DESCRIPTION

Provide and install as shown on the plans a factory-assembled, factory charged, and factory run-tested water-cooled packaged chiller. Each unit shall be complete with a two-stage helical-gear drive centrifugal compressor with hermetic motor, lubrication and control system, evaporator, condenser, economizer, refrigerant control device and any other components necessary for a complete and operable chiller package.

2.3 DESIGN REQUIREMENTS

- A. General: Provide a complete water-cooled hermetic centrifugal compressor water-chilling package as specified herein. Machine shall be provided according to referenced standards Section 1.2. In general, unit shall consist of a driveline, condenser, evaporator, economizer, lubrication system, and control system.

Note: Chillers shall use a refrigerant such as R-134a, not subject to the Montreal Protocol and the U. S. Clean Air Act.

- B. Performance: Refer to schedule on the drawings. The chiller shall be capable of stable operation to twenty percent of full load with standard AHRI entering condensing water relief without the use of hot gas bypass.
- C. Acoustics: Sound pressure levels for the complete unit shall not exceed the following specified levels. Provide the necessary acoustic treatment to chiller as required. Sound data shall be measured according to the latest version of AHRI Standard 575. Data shall be in dB. Data shall be the highest levels recorded at all load points. Test shall be in accordance with AHRI Standard 575.

Octave Band Center Freq. Hz

63	125	250	500	1000	2000	4000	8000	<b>dB</b>
----	-----	-----	-----	------	------	------	------	-----------

2.4 CHILLER COMPONENTS

- A. Compressor:

- 1. Unit shall have a 2-stage helical gear drive centrifugal compressor. Casing design shall ensure major wearing parts, main bearings, and thrust bearings are accessible for maintenance and replacement.
- 2. The impeller shall be statically and dynamically balanced. The compressor shall be vibration tested and not exceed a level of 0.14 inch per second (3.56 mm/s).
- 3. The motor driven inlet guide vanes (IGV) located at the entrance to the compressor first stage impeller control the quantity of refrigerant entering the impeller thereby controlling the compressor capacity in the first-stage and a motor driven variable diffuser or discharge diffuser control ( DDC ) in the second stage.

- B. Refrigerant Evaporator, Economizer and Condenser:

- 1. The evaporator and condenser shall be of the shell-and-tube type, the economizer will be flash type designed, constructed, tested and stamped according to the requirements of the ASME Code, Section VIII. Regardless of the operating pressure, the refrigerant side of each vessel will bear the ASME stamp indicating compliance with the code and indicating a test pressure of 1.1 times the working pressure, but not less than 100 psig. Provide intermediate tube supports at a maximum of 24 inch (610 mm) spacing.
- 2. Tubes shall be enhanced for maximum heat transfer, rolled into steel tube sheets and sealed with Loctite® or equal sealer. The tubes shall be individually replaceable.
- 3. Isolation valves will be part of the unit to hold the full refrigerant charge in the condenser.
- 4. The water sides shall be designed for a minimum of 150 psig (1034 kPa) DWP or as specified elsewhere. Vents and drains shall be provided.
- 5. Chilled water minimum temperature shall be 35°F (1.7°C).
- 6. A thermal refrigerant expansion valve shall control refrigerant flow to the economizer and float expansion valves will control refrigerant flow to the evaporator.
- 7. The evaporator, condenser and economizer shall be separate shells. A single shell containing more than one vessel functions is not acceptable because of the possibility of internal leaks.
- 8. Reseating type spring loaded pressure relief valves according to ASHRAE-15 safety code shall be furnished. The evaporator shall be provided with a single valve. The condenser shall be provided with dual relief valves equipped with a transfer valve so one valve can be removed for testing or replacement without loss of refrigerant or removal of refrigerant from the vessel. Rupture disks are not acceptable.
- 9. Factory-mounted thermal dispersion flow sensors shall be provided on each vessel to prevent unit operation with no flow.
- 10. Insulation on all cold surfaces subject to condensation, ¾-inch.

D. Prime Mover: Squirrel-cage induction motor of the hermetic type of sufficient size to efficiently fulfill compressor horsepower requirements. Motor shall be liquid refrigerant cooled with internal thermal overload protection devices embedded in the winding of each phase. Motor shall be compatible with the starting method specified hereinafter. If additional cooling is required, manufacturer shall be responsible for the installation, wiring and controls of a cooling system. Chiller selection shall compensate for tonnage and efficiency loss to make certain the owner is not penalized.

E. Motor Starter:

1. The starter must comply with the requirements of Section 1.2.

2. Low Voltage (200 through 600 volts) motor controllers are to be continuous duty AC magnetic type constructed according to NEMA standards for Industrial Controls and Systems (ICS) and capable of carrying the specified current on a continuous basis. The starter shall be:

Solid-State Reduced Voltage - Starter shall be furnished with silicon controlled rectifiers (SCR) connected for starting and include a bypass contactor. When operating speed is reached, the bypass contactor bypasses the SCRs.

-- OR --

Wye-Delta Closed Transition - The wye contactor shall be capable of handling 33% of the delta locked rotor current and be equipped with properly sized resistors to provide a smooth transition. The resistors shall be protected with a transition resistor protector, tripping in a maximum of two seconds, locking out the starter, and shall be manually reset. A clearly marked transition timer shall be adjustable from 0 to 30 seconds.

3. The starter shall be coordinated with the chiller package(s) making certain all terminals are properly marked according to the chiller manufacturer's wiring diagrams.

4. The starters shall be equipped with redundant motor control relays (MCR) with coils in parallel. The relays interconnect the starters with the unit control panels and directly operate the main motor contactors. The MCRs shall constitute the only means of energizing the motor contacts.

5. The main contactors shall have a normally open and a normally closed auxiliary contact rated at 125VA pilot duty at 115 VAC. An additional set of normally open contacts shall be provided for each MCR.

6. There shall be electronic overloads in each phase set at 107% of the rated load amps of each motor. Overloads shall be manual reset and shall de-energize the main contactors when the overcurrent occurs. The overloads shall be adjustable and selected for mid-range. Overloads shall be adjusted for a locked rotor trip time of 8 seconds at full voltage and must trip in 60 seconds or less at reduced voltage (33% of delta LRA).

7. Each starter shall have a current transformer and adjustable voltage dropping resistor(s) to supply a 5.0 VAC signal at full load to the unit control panels.

8. Each starter shall be equipped with a line-to-115 VAC control transformer, fused in both the primary and secondary, to supply power to the control panels, oil heaters and oil pumps.

9. Each starter shall have phase failure and reversal protection

Medium Voltage (601 through 5000 volts) and High Voltage (5001 through 7200 volts). The starter shall be:

1. Solid-State Reduced Voltage - Starter shall be furnished with silicon controlled rectifiers (SCR) connected for starting and include a bypass contactor. When operating speed is reached, the bypass contactor shall be energized removing the SCRs from the circuit during normal running.

2. The starter shall be coordinated with the chiller package(s) making certain all terminals are properly marked according to the chiller manufacturer's wiring diagrams.

3. The starters shall be equipped with redundant motor control relays (MCR) with coils in parallel. The relays interconnect the starters with the unit control panels and directly operate the main motor contactors. The MCRs shall constitute the only means of energizing the motor contacts.

4. The main contactors shall have a normally open and a normally closed auxiliary contact rated at 125VA pilot duty at 115 VAC. An additional set of normally open contacts shall be provided for each MCR.

5. There shall be electronic overloads in each phase set at 107% of the rated load amps of each motor. Overloads shall be manual reset and shall de-energize the main contactors when the overcurrent occurs. The overloads shall be adjustable and selected for mid-range. Overloads shall be adjusted for a locked rotor trip time of 8 seconds at full voltage and must trip in 60 seconds or less at reduced voltage (33% of delta LRA).

6. Each starter shall have a current transformer and adjustable voltage dropping resistor(s) to supply a 5.0 VAC signal at full load to the unit control panels.

7. Each starter shall be equipped with a line-to-115 VAC control transformer, fused in both the primary and secondary, to supply power to the control panels, oil heaters and oil pumps.

8. Each starter shall include the following:

a) Phase failure and reversal protection

b) Load break disconnect switch

c) Current limiting power fuses

--OR--

Across-the-Line type with primary contactor allowing locked rotor amps to reach the motor when energized.

--OR--

Autotransformer type factory wired to the 65% tap with drawout magnetic, three-pole, vacuum break shorting contactor, drawout magnetic, two-pole, vacuum break starting contactor, and open delta starting auto-transformer factory set at 65%.

--OR--

Primary Reactor type with drawout magnetic, three-pole, vacuum break shorting assembly, and three-phase starting reactor, factory set at the 65% tap.

All medium and high voltage starters shall have the following components:

**Main Control Relays**

Redundant motor control relays with coils in parallel and contacts in series to interlock the starter with the chiller. These two relays shall constitute the only means of energizing the motor contractors. No other devices (manual or automatic) with the capability of energizing the starter can be used. The starter is controlled by the unit microprocessor.

**Motor Protection and Overloads**

The starter shall include overload protection functions. These controls include:

- Solid state overload (overcurrent) protection
- Phase unbalance protection
- Phase reversal and phase loss protection.
- Adjustable overload to closely match motor performance
- Three current transformers to measure motor current and a fourth current transformer for input to the chiller microprocessor.

**Undervoltage (UV) Relay**

The undervoltage relay is an adjustable three-phase protection system that is activated when the voltage falls below a predetermined safe value and is factory set at 85% of nominal.

**Control Voltage Transformer**

The starter is provided with a 3KVA control transformer with both secondary and primary fuses to supply control power to the chiller.

**Additional Standard Components**

- Mechanical type solderless connectors to handle NEC wire sizes.
- Three isolated vertical line contactors
- Three-pole, gang operated non-load break isolating switch
- Three vertically mounted current limiting power fuse blocks (fuses included)
- Magnetic three-pole, vacuum break contactor
- Single phase control circuit transformer
- Vertically mounted control circuit primary current limiting fuses
- Current transformers
- Load terminals
- Control circuit terminal blocks and secondary fuses
- Phase failure and reversal relay

G. **CHILLER CONTROLLER**

The chiller shall have a microprocessor-based control consisting of a unit controller, a compressor controller and a 15-inch super VGA color touch screen for operator interface with the control system.

The touch screen shall have graphics clearly depicting the chiller status, operating data, including water temperatures, percent RLA, water setpoint, alarm status and have STOP and AUTO control buttons.

The operator interface touch screen shall have inherent trend logging capabilities, which are transferable to other PC management systems such as an Excel spreadsheet via a USB port. Active trend logging data shall be available for viewing in 20 minute, 2 hour or 8 hour intervals. A full 24 hours of history is downloadable via a USB port.

The following trended parameters shall be displayed:

- Entering and leaving chilled water temps
- Entering and leaving condenser water temps
- Evaporator saturated refrigerant pressure
- Condenser saturated refrigerant pressure
- Net oil pressure
- % rated load amps

In addition to the trended items above, other real-time operating parameters shall also be shown on the touch screen. These items can be displayed in two ways: by chiller graphic showing each component or from a color-coded, bar chart format. At a minimum, the following critical areas must be monitored:

- Oil sump temperature
- Oil feed line temperature
- Evaporator saturated refrigerant temperature
- Suction temperature
- Condenser saturated refrigerant temperature
- Discharge temperature
- Liquid line temperature

Unit setpoints shall be viewable on screens and changeable after insertion of a password.

Complete unit operating and maintenance instructions shall be viewable on the touch screen and be downloadable via an onboard USB port.

Automatic corrective action to reduce unnecessary cycling shall be accomplished through pre-emptive control of low evaporator or high discharge pressure conditions to keep the unit operating through ancillary transient conditions.

System specific, chiller plant architecture software shall be employed to display the chiller, piping, pumps and cooling tower. Chiller plant optimization software for up to 4 chillers shall also be included to provide automatic control of: evaporator and condenser pumps (primary and standby), up to 4 stages of cooling tower fans and a cooling tower modulating bypass valve and/or cooling tower fan variable frequency drives. There shall be five possible tower control strategies:

- Tower fan staging only – up to 4 stages controlled by either the entering condenser water temperature or lift differential temperature between the condenser and evaporator saturated temperatures.
- Tower fan staging plus low limit - controlled as in # 1 plus tower bypass valve set at a minimum entering condenser water temperature
- Tower staging with staged bypass control – similar to # 2 with additional control of the bypass valve between fan staging to smooth control and minimize fan staging.
- VFD staging only – in this mode, a variable speed drive controls the first fan with up to 3 more fans to be staged on and off and there is no bypass valve.
- VFD and Valve Staging – same as # 4 plus bypass valve control

## 2.5. MISCELLANEOUS ITEMS

- A. Waffle type vibration pads for field mounting under unit feet.

### **PART 3 — EXECUTION**

#### 3.1 INSTALLATION

- A. Install according to manufacturer's requirements, shop drawings, and Contract Documents.
- B. Adjust chiller alignment on concrete foundations, sole plates or subbases as called for on drawings.
- C. Arrange the piping on each vessel to allow for dismantling the pipe to permit head removal and tube cleaning.
- D. Coordinate electrical installation with electrical contractor.
- E. Coordinate controls with control contractor.
- F. Provide all materiel required to ensure a fully operational and functional chiller.

#### 3.2 START-UP

- A. Factory Start-Up Services: The manufacturer shall provide factory authorized supervision for as long a time as is necessary to ensure proper operation of the unit, but in no case for less than two full working days. During the period of start-up, the start-up technician shall instruct the owner's representative in proper care and operation of the unit.



For more information email [info@daikinapplied.uk](mailto:info@daikinapplied.uk) or visit [www.daikinapplied.uk](http://www.daikinapplied.uk)

For all Daikin Applied UK,  
Daikin Applied Service &  
Spares enquiries call us on:  
**0345 565 2700**



Daikin Europe N.V. participates in the Eurovent Certified Performance programme for Liquid Chilling Packages and Hydronic Heat Pumps, Fan Coil Units and Variable Refrigerant Flow systems. Check ongoing validity of certificate: [www.eurovent-certification.com](http://www.eurovent-certification.com)

The present publication is drawn up by way of information only and does not constitute an offer binding upon Daikin Europe N.V. Daikin Europe N.V. has compiled the content of this publication to the best of its knowledge. No express or implied warranty is given for the completeness, accuracy, reliability or fitness for particular purpose of its content and the products and services presented therein. Specifications are subject to change without prior notice. Daikin Europe N.V. explicitly rejects any liability for any direct or indirect damage, in the broadest sense, arising from or related to the use and/or interpretation of this publication. All content is copyrighted by Daikin Europe N.V.

