

EWV(D)(H)(S)-VZ

Water cooled chillers with variable speed compressor

Installation, maintenance & operation manual



Cooling capacity from 450 kW to 2100 kW
Refrigerant: R134a or R1234ze

D-EIMWC003H02-18_05EN

REV	05
Date	January 2023
Supersedes	D-EIMWC003H02-18_04EN



Contents

1	INTRODUCTION	8
1.1	Precautions against residual risks	8
1.2	General Description	9
1.3	Application.....	9
1.4	Information about refrigerant R1234ze(E)	9
1.5	Safety installation.....	10
1.5.1	Safety devices	10
1.5.2	Additional guidelines for safe use of R1234ze(E) for equipment located in the open air	11
1.5.3	Additional guidelines for safe use of R1234ze(E) for equipment located in a machinery room.....	11
2	INSTALLATION.....	13
2.1	Storage.....	13
2.2	Receiving and handling.....	13
2.3	Lifting instructions	14
2.4	Positioning and assembly	15
2.5	Shock absorbers	15
2.6	Anchoring.....	16
2.7	Water pipes	16
2.7.1	Evaporator and condenser water pipes.....	16
2.7.2	Flow Switch.....	16
2.7.3	Water treatment.....	17
2.8	Temperature limits and water flow	17
2.8.1	Operating limits EWWD-VZ.....	18
2.8.2	Operating limits EWWH-VZ.....	19
2.8.3	Operating limits EWWS-VZ.....	20
2.9	Minimum water content in the system	21
2.10	Evaporator freeze protection.....	21
2.11	Condenser protection and design considerations	21
2.11.1	Condensation control with evaporative cooling tower	21
2.11.2	Condensation control with well water	23
2.12	Chilled water control sensor.....	23
2.13	Safety Valve	23
2.14	Open the isolation and/or shut off valves.....	23
2.15	Electrical connections	24
2.16	Phase imbalance	24
2.17	Control circuit	25
3	OPERATION.....	26
3.1	Operator's responsibilities.....	26
3.2	Unit description	26
3.3	Cooling cycle description	27
3.3.1	Evaporator	27
3.3.2	Condenser	27
3.3.3	Expansion valve	27
3.3.4	Compressors	27
3.3.5	Capacity control.....	28
3.3.6	Volumetric variable compression ratio (VVR).....	28
3.3.7	Oil management system.....	28
3.3.8	Oil recovery system	29
3.3.9	Electrical Control Panel	29
3.3.10	Safeties for each refrigerant circuit.....	30
3.3.11	System safeties	30
3.3.12	Regulation type.....	30
3.3.13	Compressor alternation	31
3.3.14	High pressure condensation control.....	31
3.3.15	High pressure mechanical safety pressure switch	31
3.3.16	Compressor motor protection	31
4	MAINTENANCE	32
4.1	Maintenance and repair	32
4.2	Pressure/Temperature Table	33
4.3	Routine maintenance	34

4.3.1	Check condenser performance	34
4.3.2	Electronic expansion valve.....	34
4.3.3	Cooling circuit	34
4.3.4	Delivery and suction valves (optional).....	34
4.3.5	Refrigerant charge	36
4.3.6	Electrical Installation.....	36
4.4	Cleaning and Storage	36
4.5	Seasonal maintenance	37
4.5.1	Seasonal shutdown	37
4.5.2	Seasonal start up	37
5	SERVICE SCHEDULE	38
6	MAINTENANCE SCHEDULE	39
7	PRECOMMISSIONING CHECK LIST	41
8	IMPORTANT INFORMATION REGARDING THE REFRIGERANT USED	43
8.1	Factory and Field charged units instructions	43
9	PERIODIC CHECKS AND COMMISSIONING OF PRESSURE VESSELS	44
10	DEMOLITION AND DISPOSAL	44

List of figures

Figure1	- Description of the labels applied to the unit.....	5
Figure2	- Description of the labels applied to the electric panel	7
Figure3	- Lifting instructions	14
Figure4	- Unit positioning	15
Figure5	- Envelope EWWD_VZ_SS.....	18
Figure6	- EWWD-VZ-XS/PS.....	18
Figure7	- EWWH_VZ_SS.....	19
Figure8	- EWWH_VZ_XS.....	19
Figure9	- EWWS_VZ_XS/PS	20
Figure10	- EWWS_VZ_SS	20
Figure11	- Condenser control scheme with cooling tower	22
Figure12	- Condensation control scheme with well water.....	23
Figure13	- Unit interface	30
Figure14	- Typical single circuit cooling circuit.....	35
Figure15	- Typical dual circuit cooling circuit	35

Figure1 - Description of the labels applied to the unit

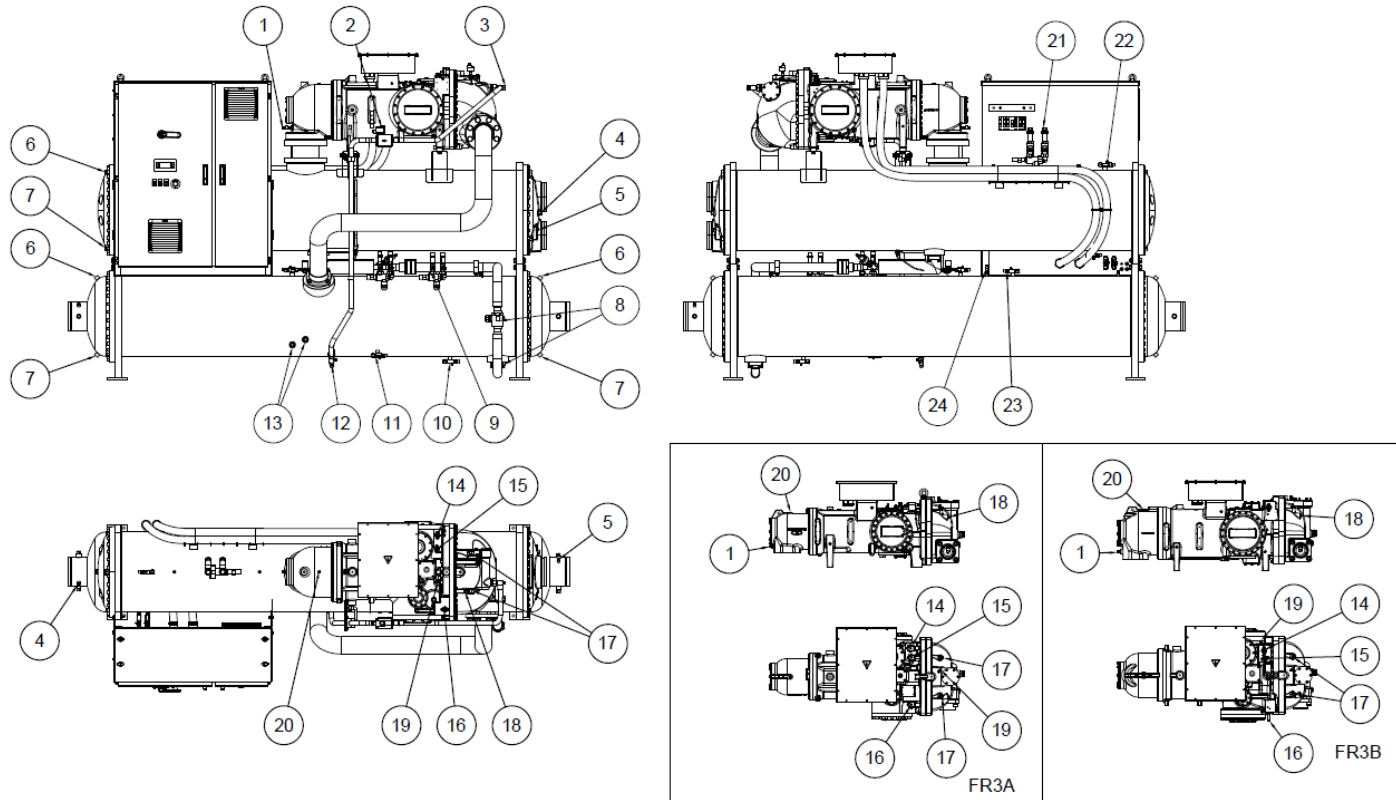

Single circuit unit

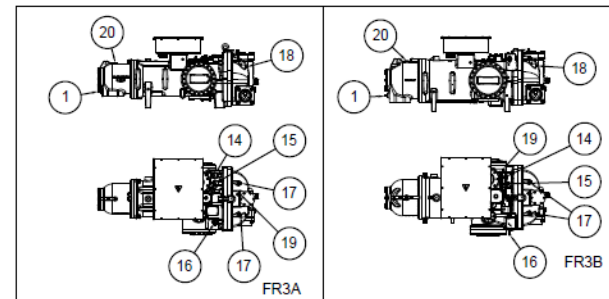
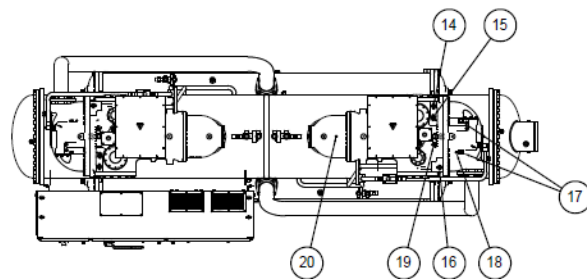
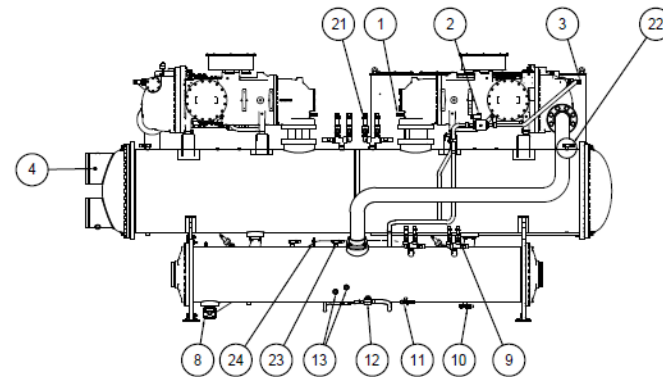
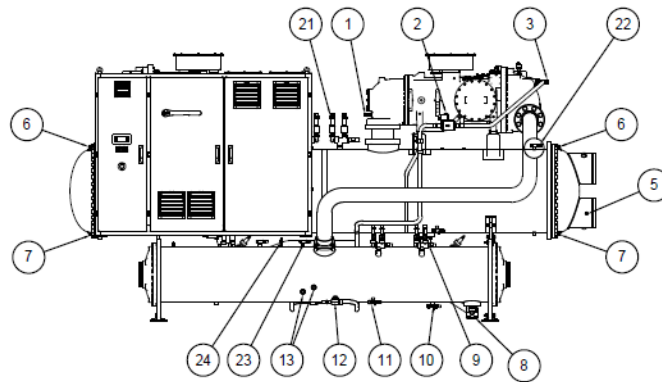

Double circuit unit

1	Low pressure transducer	13	Oil level
2	Oil injection solenoid valve	14	VVR solenoid valve circ.1 (3.1 VR)
3	Oil flow sight glass	15	VVR solenoid valve circ.1 (2.4 VR)
4	Leaving water temperature sensor	16	VVR solenoid valve circ.1 (1.8 VR)
5	Entering water temperature sensor	17	High pressure switch
6	Air purge	18	Discharge temperature sensor
7	Water drain	19	Oil Pressure Transducer
8	Liquid line shut-off valve	20	Suction temperature sensor
9	High pressure safety valves	21	Low Pressure safety valves
10	Refrigerant charge service valve	22	Service valve
11	Oil discharge service valve	23	Jet pump valve
12	Oil line shut-off valve	24	High pressure transducer

Figure2 - Description of the labels applied to the electric panel

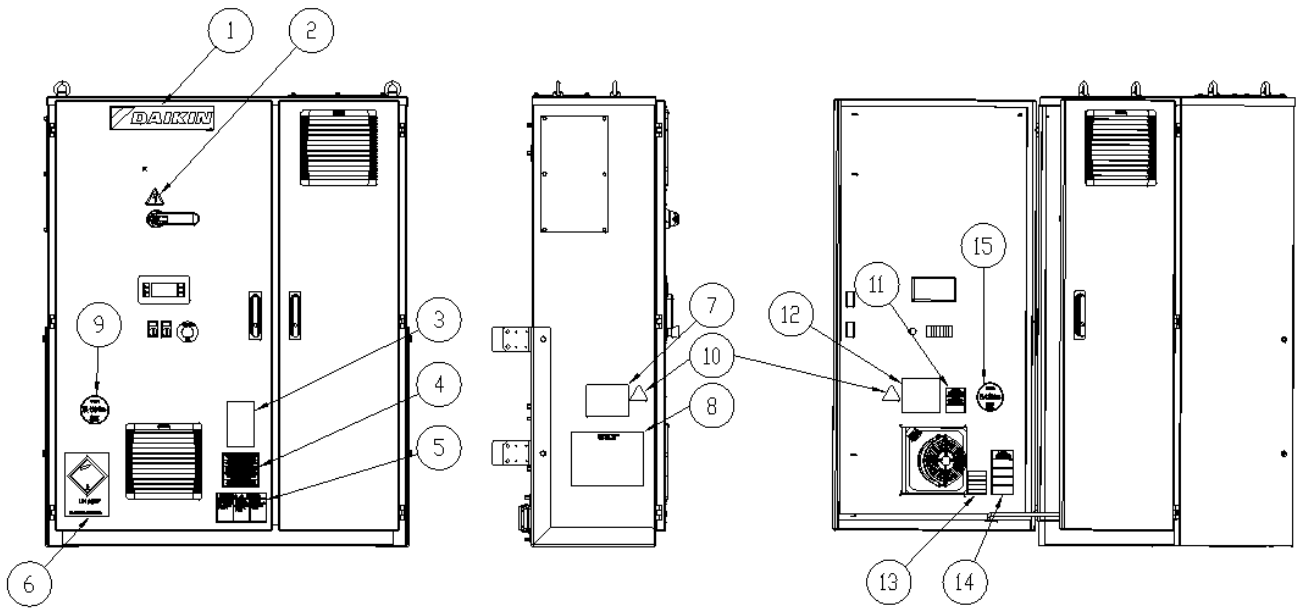

Single circuit unit

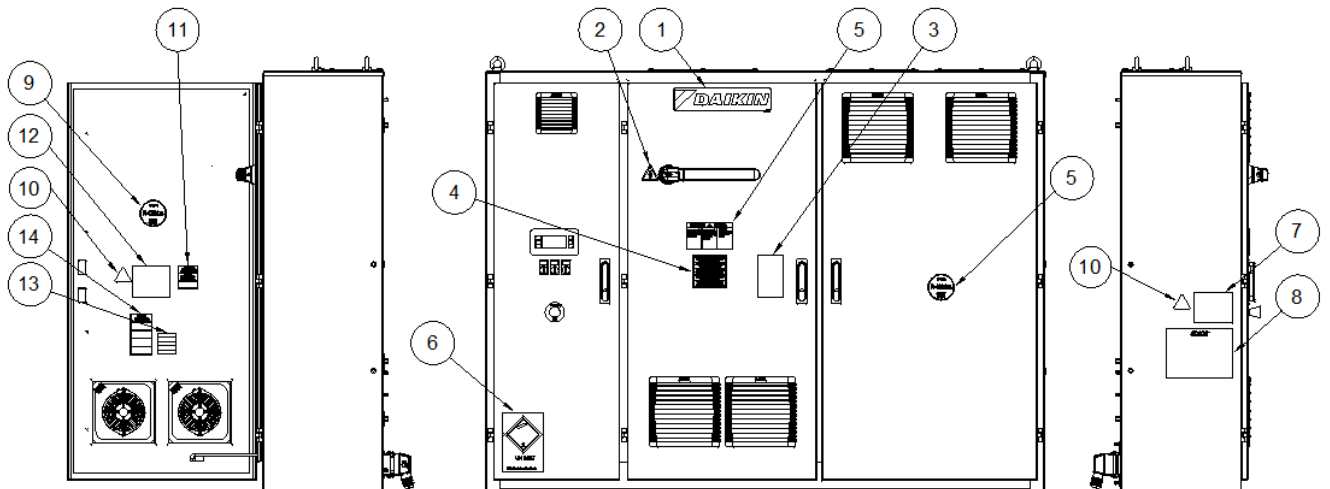

Double circuit unit

Identification of labels

1	Manufacturer's logo	8	Lifting instructions
2	Electricity warning	9	Refrigerant
3	Shutoff valve position	10	W012 Symbol
4	Wire tightness check	11	Attention Closed Valve
5	High Voltage Danger	12	Attention
6	Transportation Label UN 2857	13	Copper Cables
7	Unit nameplate	14	Pressure Gauge Valves

1 INTRODUCTION

This manual provides information about the capabilities and standard procedures for all units in the series and is an important support document for qualified personnel, but it is not intended to replace such personnel.

All units are supplied complete with wiring diagrams and dimensional drawings that provide information about the size and weight of each model.

In case of discrepancies between the content of the manual and the documentation that came with the unit, always rely to the wiring diagram and dimensional drawings because **they are an integral part of this manual**.

Read this manual carefully before installing and starting up the unit.

Improper installation can cause shock, short circuits, leaks, fire or other damages to the equipment or personal injury.

The unit must be installed by professionals/professional technicians in accordance with current laws of the country of installation.

The unit must also be started by authorized and trained personnel and all activities must be conducted in accordance and in full compliance with local standards and laws.

IF THE INSTRUCTIONS IN THIS MANUAL ARE NOT ABSOLUTELY CLEAR, DO NOT INSTALL AND/OR START UP THE UNIT.

If in doubt, for service and further information, contact the manufacturer's authorized representative.

1.1 Precautions against residual risks

1. install the unit according to the instructions set out in this manual
2. regularly carry out all the maintenance operations foreseen in this manual
3. wear protective equipment suited to the work in hand; do not wear clothes or accessories that can get caught or sucked in by flows of air; tie back long hair before entering the unit
4. before opening the machine panelling make sure that it is firmly hinged to the machine
5. the fins on heat exchangers and the edges of metal components and panels can cause cuts
6. do not remove the guards from mobile components while the unit is operating
7. make sure that mobile component guards are fitted correctly before restarting the unit
8. fans, motors and belts drives might be running: before entering, always wait for these to stop and take appropriate measures to prevent them from starting up
9. the surfaces of the machine and pipes can get very hot or cold and cause the risk of scalding
10. never exceed the maximum pressure limit (PS) of the water circuit of the unit
11. before removing parts on the pressurised water circuits, close the section of the piping concerned and drain the fluid gradually to stabilise the pressure at the atmospheric level
12. do not use your hands to check possible refrigerant leaks
13. disable the unit from the mains using the main switch before opening the control panel
14. check that the unit has been grounded correctly before starting it
15. install the machine in a suitable area; in particular, do not install it outdoors if it is intended for use indoors
16. do not use cables with inadequate sections nor extension cord connections, even for very short periods or emergencies
17. for units with power correction capacitors, wait 5 minutes after removing the electric power supply before accessing the inside of the switch board
18. if the unit is equipped with compressors with integrated inverter, disconnect it from the mains and wait a minimum of 20 minutes before accessing it to carry out maintenance: residual energy in the components, which takes at least this length of time to dissipate, poses the risk of electrocution
19. the unit contains pressurised refrigerant gas: the pressurised equipment must not be touched except during maintenance, which must be entrusted to qualified and authorized personnel
20. connect up the utilities to the unit following the indications set out in this manual and on the panelling of the unit itself
21. In order to avoid an environmental risk, make sure that any leaking fluid is collected in suitable devices in accordance with local regulations.
22. if a part needs to be dismantled, make sure it is correctly re-assembled before starting the unit
23. when the rules in force require the installation of fire-fighting systems near the machine, check that these are suitable for extinguishing fires on electrical equipment and on the lubricating oil of the compressor and the refrigerant, as specified on the safety data sheets of these fluids
24. when the unit is equipped with devices for venting overpressure (safety valves): when these valves are triggered, the refrigerant gas is released at a high temperature and speed; prevent the release of gas from harming people or objects and, if necessary, discharge the gas according to the provisions of EN 378-3 and the local regulations in force.

25. keep all the safety devices in good working order and check them periodically according to the regulations in force
26. keep all lubricants in suitably marked containers
27. do not store inflammable liquids near the unit
28. solder or braze only empty pipes after removing all traces of lubricant oil; do not use flames or other heat sources in the vicinity of pipes containing refrigerant fluid
29. do not use naked flames near the unit
30. the machinery must be installed in structures protected against atmospheric discharge according to the applicable laws and technical standards
31. do not bend or hit pipes containing pressurised fluids
32. it is not permitted to walk or rest other objects on the machine
33. the user is responsible for overall evaluation of the risk of fire in the place of installation (for example, calculation of the fire load)
34. during transport, always secure the unit to the bed of the vehicle to prevent it from moving about and overturning
35. the machine must be transported according to the regulations in force taking into account the characteristics of the fluids in the machine and the description of these on the safety data sheet
36. inappropriate transport can cause damage to the machine and even leaking of the refrigerant fluid. Before start-up, the machine must be checked for leaks and repaired accordingly.
37. the accidental discharge of refrigerant in a closed area can cause a lack of oxygen and, therefore, the risk of asphyxiation: install the machinery in a well ventilated environment according to EN 378-3 and the local regulations in force.
38. the installation must comply with the requirements of EN 378-3 and the local regulations in force; in the case of installations indoors, good ventilation must be guaranteed and refrigerant detectors must be fitted when necessary.

1.2 General Description

Daikin water chillers with screw compressor Inverters, are completely factory assembled and tested before shipment.

The machine, extremely compact, uses R134a/R1234ze(E)/R513A refrigerant suitable for the entire machine application range.

The controller is pre-wired, set and tested at the factory. Only normal connections are required on site such as piping, electrical connections and pump interlocks, making installation easier and more reliable. All operating safety and control systems are factory installed in the control panel.

The instructions in this manual apply to all models of this series unless otherwise indicated.

1.3 Application

The EWWD/(EWWH/EWWS) VZ units with single screw compressor and adjustment inverters are designed and constructed to cool and/or heat buildings or industrial processes. Daikin technicians, specifically trained for this purpose, must start the final system for the first time. Failure to follow this starting procedure affects the warranty.

The standard warranty covers parts of this equipment with proven defects in material or workmanship. Materials subject to natural consumption are not, however, covered by the warranty.

The cooling towers used with Daikin units with screw compressor must be selected for a wide scope of application, as described in the "Operating limits" section. From an energy savings point of view it is always preferable to keep the temperature difference between the hot circuit (condenser) and the cold circuit (evaporator) to a minimum. However, it is always necessary to verify that the machine works in the temperature range specified in this manual.

1.4 Information about refrigerant R1234ze(E)

This product can be equipped with refrigerant R1234ze(E) which has minimal impact to the environment, thanks to its low value of Global Warming Potential (GWP). R1234ze(E) refrigerant is classified by European Directive 2014/68/EU as a Group 2 (non-dangerous) substance, as it is nonflammable at standard ambient temperature and non-toxic. Due to this, no special precautions are required for storage, transport and handling.

Daikin Applied Europe S.p.A. products comply with applicable European Directives and refer for unit design to product Standard EN378:2016 and industrial Standard ISO5149. Local authorities approval should be verified referring to European Standard EN378 and/or ISO 5149 (where R1234ze(E) is classified A2L – Mildly flammable gas).

Physical characteristics of refrigerant R1234ze (E)

Safety Class	A2L
PED Fluid Group	2
Practical limit (kg/m ³)	0.061
ATEL/ ODL (kg/m ³)	0.28
LFL (kg/m ³) @ 60 °C	0.303
Vapour density @25 °C, 101.3 kPa (kg/m ³)	4.66
Molecular Mass	114.0
Normal Boling Point (°C)	-19
GWP (100 yr ITH)	7
GWP (ARS 100 yr ITH)	<1
Auto Ignition Temperature (°C)	368

1.5 Safety installation

The chiller has to be installed in open air or machinery room (location classification III).

To ensure location classification III a mechanical vent on the secondary circuit(s) has to be installed.

DAE units can be installed without charge restrictions into machinery rooms or in open air (location class.III).

According to EN 378-1, a mechanical vent on the secondary circuit(s) has to be installed: to ensure location classification III the system shall be classified as an “indirect vented closed system”.

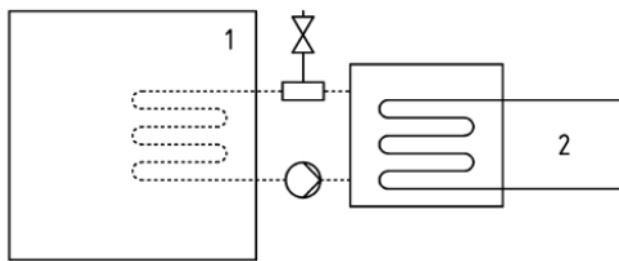

Indirect vented closed system

Key

- 1) Occupied Space
- 2) Refrigerant containing part(s)

Machinery rooms shall not be considered occupied space (except as defined in part 3, 5.1: machinery room used as a maintenance workspace shall be considered occupied spaces under access category c).

Local building codes and safety standards shall be followed; in absence of local codes and standards refer to EN 378-3:2016 as a guide.

In paragraph “Additional guidelines for safe use of R1234ze(E)” there are provided additional information that should be added to the requirements of safety standards and building codes.

Each exchanger (evaporator and condenser) is provided with a safety valve installed on a changeover valve that allows maintenance and periodic checks, without losing a significant amount of refrigerant. Do not leave the safety valve in the intermediate position.

To prevent damages due to inhalation and direct contact with refrigerant gas, the safety valve outlets must be connected with a conveyor pipe before operations. These pipes must be installed so that, in case the valve opens, the discharged refrigerant flow not invest people and/or things, or can enter the building through windows and/or other openings.

The installer is responsible for connecting the safety valve to the purge pipe and pipe dimensioning. In this regard, refer to the harmonized standard EN13136 to dimension the drain pipes to be connected to the safety valves.

All precautions concerning handling of refrigerant must be observed in accordance with local regulations.

1.5.1 Safety devices

In accordance with the Pressure Equipment Directive the following protection devices are used:

- High pressure switch → safety accessory.
- External relief valve (refrigerant side) → over pressure protection.
- External relief valve (heat transfer fluid side) → **The selection of these relief valves must be made by the personnel responsible for completing the hydraulic circuit(s).**

All factory-installed relief valves are lead-sealed to prevent any calibration change.

If the relief valves are installed on a changeover valve, this is equipped with a relief valve on both outlets. Only one of the two relief valves is operating, the other one is isolated. Never leave the changeover valve in the intermediate position.

If a relief valve is removed for checking or replacement please ensure that there is always an active relief valve on each of the changeover valves installed in the unit.

1.5.2 Additional guidelines for safe use of R1234ze(E) for equipment located in the open air

Refrigerating systems sited in the open air shall be positioned to avoid leaked refrigerant flowing into a building or otherwise endangering people and property.

The refrigerant shall not be able to flow into any ventilation fresh air opening, doorway, trap door or similar opening in the event of a leak. Where a shelter is provided for refrigerating equipment sited in the open air it shall have natural or forced ventilation.

For refrigeration systems installed outside in a location where a release of refrigerant can stagnate e.g. below ground, then the installation shall comply with the requirements for gas detection and ventilation of machinery rooms.

1.5.3 Additional guidelines for safe use of R1234ze(E) for equipment located in a machinery room

When a machinery room is chosen for the location of the refrigerating equipment it shall be located in accordance with local and national regulations. The following requirements (according to EN 378-3:2016) can be used for the assessment.

- A risk analysis based on the safety concept for the refrigerating system (as determined by the manufacturer and including the charge and safety classification of the refrigerant used) shall be conducted to determine whether it is necessary to place the refrigerating system in a separate refrigeration machinery room.
- Machinery rooms should not be used as occupied spaces. The building owner or user shall ensure that access is permitted only by qualified and trained personnel doing the necessary maintenance to the machinery room or general plant.
- Machinery rooms shall not be used for storage with the exception of tools, spare parts and compressor oil for the installed equipment. Any refrigerants, or flammable or toxic materials shall be stored as required by national regulations.
- Open (naked) flames shall not be permitted in machinery rooms, except for welding, brazing or similar activity and then only provided the refrigerant concentration is monitored and adequate ventilation is ensured. Such open flames shall not be left unattended.
- A remote switching (emergency type) for stopping the refrigerating system shall be provided outside the room (near the door). A similar acting switch shall be located at a suitable location inside the room.
- All piping and ducting passing through floors, ceiling and walls of machinery room shall be sealed.
- Hot surfaces shall not exceed a temperature of 80% of the auto-ignition temperature (in °C) or 100 K less than the auto-ignition temperature of the refrigerant, whichever is higher.

Refrigerant	Auto ignition temperature	Maximum surface temperature
R1234ze	368 °C	268 °C

- Machinery rooms shall have doors opening outward and sufficient in number to ensure freedom for persons to escape in an emergency; the doors shall be tight fitting, self-closing and so designed that they can be opened from inside (antipanic system).
- Special machinery rooms where the refrigerant charge is above the practical limit for the volume of the room shall have a door that either opens directly to the outside air or through a dedicated vestibule equipped with self-closing, tight-fitting doors.
- The ventilation of machinery rooms shall be sufficient both for normal operating conditions and emergencies.
- Ventilation for normal operating conditions shall be in accordance with national regulations.
- The emergency mechanical ventilation system shall be activated by a detector(s), located in the machinery room.
 - This ventilation system shall be:
 - independent of any other ventilation system on the site;
 - provided with two independent emergency controls one located outside the machinery room, and the other inside.
 - The emergency exhaust ventilation fan shall:

- be either in the air flow with the motor outside the airflow, or rated for hazardous areas (according to the assessment);
 - be located to avoid pressurization of the exhaust ductwork in the machinery room;
 - not cause sparks to occur if it contacts the duct material.
- Airflow of the emergency mechanical ventilation shall be at least

$$V = 0,014 \times m^{2/3}$$

where

V is the air flow rate in m³/s;

m is the mass of refrigerant charge, in kg, in the refrigerating system with the largest charge, any part of which is located in the machinery room;

0,014 is a conversion factor.

- Mechanical ventilation shall be operated continuously or shall be switched on by the detector.
- Detector shall automatically activate an alarm, start mechanical ventilation and stop the system when it triggers.
- The location of detectors shall be chosen in relation to the refrigerant and they shall be located where the refrigerant from the leak will concentrate.
- The positioning of the detector shall be done with due consideration of local airflow patterns, accounting for location sources of ventilation and louvers. Consideration shall also be given to the possibility of mechanical damage or contamination.
- At least one detector shall be installed in each machinery room or the occupied space being considered and/or at the lowest underground room for refrigerants heavier than air and at the highest point for refrigerants lighter than air.
- Detectors shall be continuously monitored for functioning. In the case of a detector failure, the emergency sequence should be activated as if refrigerant had been detected.
- The pre-set value for the refrigerant detector at 30 °C or 0 °C, whichever is more critical, shall be set to 25 % of the LFL. The detector shall continue to activate at higher concentrations.

Refrigerant	LFL	Pre-set alarm	
		kg/m ³	ppm
R1234ze	0,303 kg/m ³	0,07575 kg/m ³	16500 ppm

- All electrical equipment (not only the refrigerating system) shall be selected to be suitable for use in the zones identified in the risk assessment. Electrical equipment shall be deemed to comply with the requirements if the electrical supply is isolated when the refrigerant concentration reaches 25 % of the lower flammable limit or less.
- Machinery rooms or special machinery rooms shall be **clearly marked** as such on the entrances to the room, together with warning notices indicating that unauthorized persons shall not enter, and that smoking, naked light or flames are prohibited. The notices shall also state that, in the event of an emergency, only authorized persons conversant with emergency procedures shall decide whether to enter the machinery room. Additionally, warning notices shall be displayed prohibiting unauthorized operation of the system.
- The owner / operator shall keep an updated logbook of the refrigerating system.



The optional leak detector supplied by DAE with the chiller should be used exclusively to check refrigerant leakage from the chiller itself

2 INSTALLATION

2.1 Storage

Should it be necessary to store the unit prior to installation, it is necessary to observe some precautions.

- Do not remove the protective plastic
- Do not leave the unit exposed to the elements
- Do not expose the unit to direct sunlight
- Do not use the machine near a heat source and/or open flame
- Keep in places where room temperature is between +5 °C to 55 °C (room temperature over the maximum limit may trigger the safety valve resulting in loss of refrigerant).

2.2 Receiving and handling

Inspect the unit immediately after delivery. Make sure the machine is intact in all its parts and that there are no deformations due to collisions. Should damages be found upon receipt, immediately file a written complaint with the carrier.

Machine returns are Ex-factory Daikin Applied Europe SpA.

Daikin Applied Europe SpA. cannot be held liable for any equipment damages incurred during transportation to the place of destination.

The isolation of the evaporator corners, where the lifting holes are located, are shipped separately and must be assembled on site after the unit has been permanently installed. Even the anti-vibration pads (optional) are shipped separately. Make sure these items, if required, are delivered with the unit.

Use extreme caution when handling the unit to prevent damage to the control panel and the refrigerant pipes.

The unit must be lifted by inserting a hook in each of the four corners, where the lifting holes are located (see lifting instructions). Distancer bars must be used along the line connecting the lifting holes to prevent damages to the electrical panel and the compressor terminal box (see figure). Do not use any other point to lift the machine.

During the lifting phase, check that the lifting cords and/or chains do not touch the electrical panel and/or piping.

If, to move the machine, slides or shoes are used, just push the base of the machine without touching the copper and steel pipes, compressors and/or electric panel.

Be careful not to hit, during handling, pipes, cables and installed accessories.

All the necessary devices guaranteeing personal safety must be provided during machine handling.

2.3 Lifting instructions

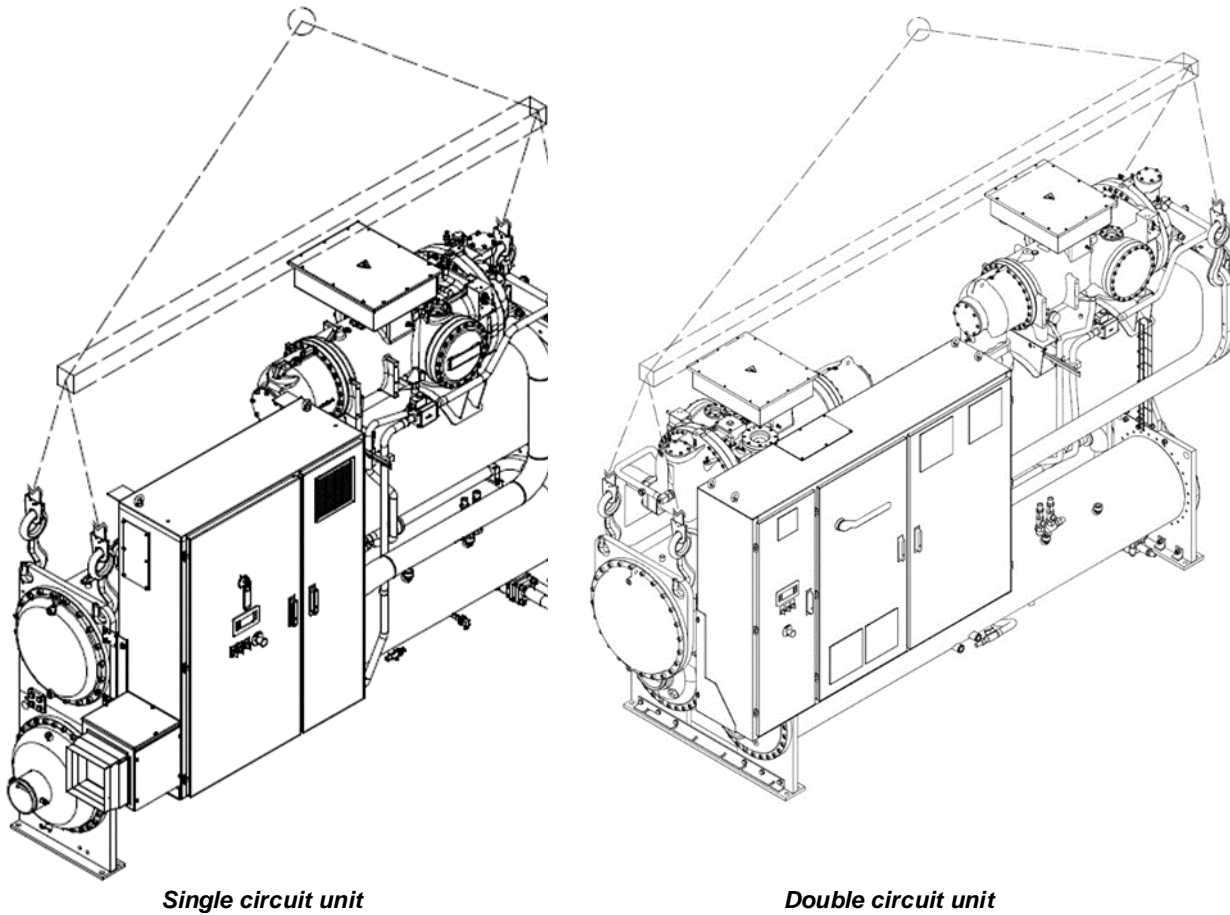
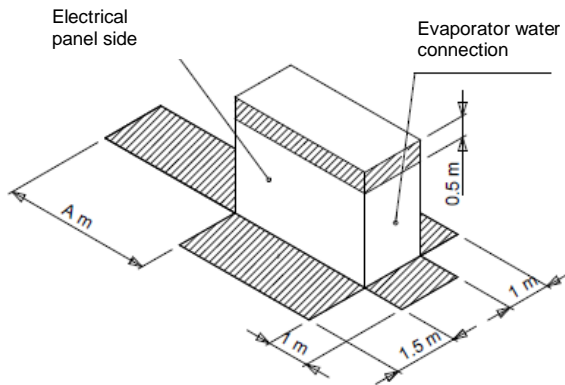

Figure3 - Lifting instructions

- 1) Equipment, ropes, lifting accessories and handling procedures must comply with local regulations and legislation.
- 2) To lift the machine, use only the holes on the heat exchangers.
- 3) Any lifting points should be used during handling.
- 4) Use lifting hooks with closing device exclusively. The hooks must be safely secured prior to handling.
- 5) The ropes and hooks used must have capacity suited to the load. Check the nameplate on the unit that indicates the machine weight.
- 6) The installer must correctly select and use lifting equipment. We recommend using cables with minimum vertical capacity equal to the total machine weight.
- 7) The machine must be lifted slowly and well leveled. Adjust the lifting equipment, if necessary, to ensure the leveling.

2.4 Positioning and assembly

The unit must be mounted on a level cement or steel base, suitable to support the overall weight of the complete machine in operation, and must be positioned so as to provide space for maintenance at one end of the unit, to allow the cleaning and/or the removal of the evaporator and the condenser pipes. Refer to the figure below for the areas of respect. The condenser and evaporator pipes are expanded inside the pipe plate to allow replacement, if necessary.



Unit type	A (m)
VZ Single Circuit	3.5
VZ Dual Circuit	4.5

Figure4 - Unit positioning

The machine position should be designed to ensure access to all the safety and control devices. Never cover the safety devices (safety valves, pressure switches), which, due to their importance, are subject to periodic checks. The safety valves must be connected externally. For safety valve outlet pipe dimensions, we recommend applying harmonized standards EN378 and EN13136.

These units include the installation of two safety valves for each exchanger, installed on changeover device, which always maintains an active valve. Thus, both safety valves on each exchanger must be connected outside the machinery room. These pipes must be installed so that, in case the valve opens, the discharged refrigerant flow does not invest people and/or things, or can enter the building through windows and/or other openings.

The engine room must be adequately ventilated to prevent refrigerant accumulation inside that can deprive air of the right oxygen content that can cause asphyxiation. In this regard, we recommend the application of harmonized standard EN378-3 (Safety and Environmental Requirements - Installation and protection of persons) or equivalent.



The air contaminated by a high percentage of refrigerant (see refrigerant safety sheet), can cause asphyxiation, loss of mobility and consciousness if inhaled. Avoid eye and skin contact.

2.5 Shock absorbers

The anti-vibration rubber mats (optional), shipped separately, should be placed under the corners of the unit (except for special specifications). These mats provide a minimum insulation. Mats are recommended on all installations where the transmission of vibrations can be considerable. Also install the anti-vibration joints on water pipes to reduce the stress on pipes, vibrations, and noise.



The units are shipped with refrigerant valves closed to isolate such fluids during shipment. The valves must remain closed until such time as an authorized Daikin technician, after inspecting the machine and checked its installation, commissions the machine.

2.6 Anchoring

After positioning, the machine must be firmly anchored to the ground or foreseen metal structure to support the machine. In this regard, 22 mm diameter holes are included on the machine base to ensure the anchoring.

2.7 Water pipes

2.7.1 Evaporator and condenser water pipes

The condensers and evaporators are provided with grooved sleeves for Victaulic connections or optionally with flanged connections. The installer must provide the mechanical coupling with the connections appropriately sized to the system.



Important notes regarding welding

- 1. If the connection flanges require welding, remove the temperature sensors from the wells, to prevent damage to the controller electronic boards.***
 - 2. Grounding must be done correctly to avoid damage to the electronic controller.***
 - 3. Start the mechanical ventilation of machinery room for any service operation.***
-

Some pressure couplings are included on both the inlet and outlet of the exchanger's heads. These couplings control water load loss. Water load loss and flow for condensers and evaporators are shown in the relevant product manual. To identify the heat exchanger, refer to its plate.

Make sure that the water inlet and outlet connections agree with the dimensional drawing and the indications found on the connections. Incorrect water pipe installation could create machine malfunctions and/or reduce performance.

When using a hydraulic connection shared with the heating system, make sure the temperature of the water flowing into the evaporator does not exceed the maximum allowed value. This phenomenon might cause the safety valve to open and thus the refrigerant to discharge into the atmosphere.

The pipes, before being attached to the machine, must be supported to reduce the weight and the stress on connections. In addition, the pipes must be adequately insulated. A water filter that can be inspected must also be installed on both inputs (evaporator and condenser). Install shutoff valves on both heat exchangers with suitable dimensions to permit draining and inspection without having to completely drain the system in addition to the water pressure gages.



To prevent damage to exchanger pipes, install a mechanical filter.

Recommended maximum opening for strainer mesh is:

0,87 mm (DX S&T)

1,0 mm (BPHE)

1,2 mm (Flooded)

For double circuit units only one temperature transducer (TT) for the condenser water outlet and one for the condenser water inlet are provided. After the connection of the two water circuits the installer must relocate the water outlet TT on the manifold.

2.7.2 Flow Switch

A flow switch must be installed on the evaporator inlet pipe to ensure the correct water flow rate, before the unit is started. Furthermore, this device shuts off the unit when water flow is interrupted, protecting the machine from the evaporator freezing.



The flow switch must not be used as a machine control system

The absence of the flow switch on the evaporator water connection, voids the warranty for frost damage.



The evaporator and condenser are not self-draining; both must be purged

Thermometers and pressure gages must be installed on the water pipes near the heat exchangers connections. Furthermore, breather valves must also be installed at the highest points on the pipe.

If necessary, only the evaporator water caps can be reversed. If this operation is completed, new gaskets and control sensors have to be repositioned.



Condenser inlet and outlet water connections cannot be reversed. The particular condenser configuration only provides optimal machine operations in countercurrent. The wrong water flow direction in the condenser reduces the overall efficiency of the machine

Should water pump noise be excessive, we recommend using rubber insulating joints at both pump inlet and outlet. In most cases it is not necessary to install anti-vibration joints on condenser pipe inlet and outlet but, where the noise and vibration are critical (for example where a buried pipe passes through a wall in an inhabited area), it may be necessary.

If a cooling tower is used, a balancing valve must be installed. A temperature control system is required if the water tower is very cold. The controller installed on the machine manages tower fan on/off or continuously manages a control valve or fan speed controller by means of a 0-10 V DC analog signal. We recommend that you carry out the connection, allowing fan management by the machine controller (see wiring diagram for connection).

2.7.3 Water treatment

Before commissioning the machine, clean the water circuits. Make sure that the tower purge and emptying system is operational. Atmospheric air contains many contaminants, so you need a good water treatment.

The use of untreated water can result in corrosion, erosion, mud, fouling and formation of algae. Daikin Applied Europe is not liable for equipment damage or malfunction due to a lack of a water treatment or water not properly treated.



**Use industrial glycol only.
Do not use automotive antifreeze.
Automotive antifreeze contains inhibitors which cause a plating on copper pipes.
Used glycol handling and disposal must be in accordance with current regulations**

DAE Water quality requirements	Shell&tube	BPHE
Ph (25 °C)	6.8 ÷ 8.4	7.5 – 9.0
Electrical conductivity [μ S/cm] (25 °C)	< 800	< 500
Chloride ion [mg Cl ⁻ / l]	< 150	< 70 (HP1); < 300 (CO ₂)
Sulphate ion [mg SO ₄ ²⁻ / l]	< 100	< 100
Alkalinity [mg CaCO ₃ / l]	< 100	< 200
Total Hardness [mg CaCO ₃ / l]	< 200	75 ÷ 150
Iron [mg Fe / l]	< 1	< 0.2
Ammonium ion [mg NH ₄ ⁺ / l]	< 1	< 0.5
Silica [mg SiO ₂ / l]	< 50	NO
Chlorine molecular (mg Cl ₂ /l)	< 5	< 0.5

2.8 Temperature limits and water flow

The units are designed to operate with an evaporator outlet water temperature between +4 °C and +15 °C and a condenser outlet water temperature between 15 °C and 50 °C (standard units). However, the minimum temperature difference between the evaporator outlet water temperature and the condenser inlet water temperature must not be less than 15 °C. Always check the exact operating point with the selection software. Some simultaneous operating conditions (high evaporator inlet water temperature and high condenser inlet water temperature) may be inhibited.

Glycol must be used for all applications with the evaporator outlet fluid below 4 °C. The maximum permissible water temperature in the evaporator with the machine off is 50 °C. Higher temperatures could cause the safety valves on the evaporator sleeve to open. Water flow rate under the minimum value indicated in the condenser and evaporator load loss diagram can cause freezing problems, incrustations and poor control. Water flow rate higher than the maximum value indicated in the condenser and evaporator load loss diagram results in an unacceptable load loss and excessive erosion of the pipes and vibrations that can cause breakage.

2.8.1 Operating limits EWWD-VZ

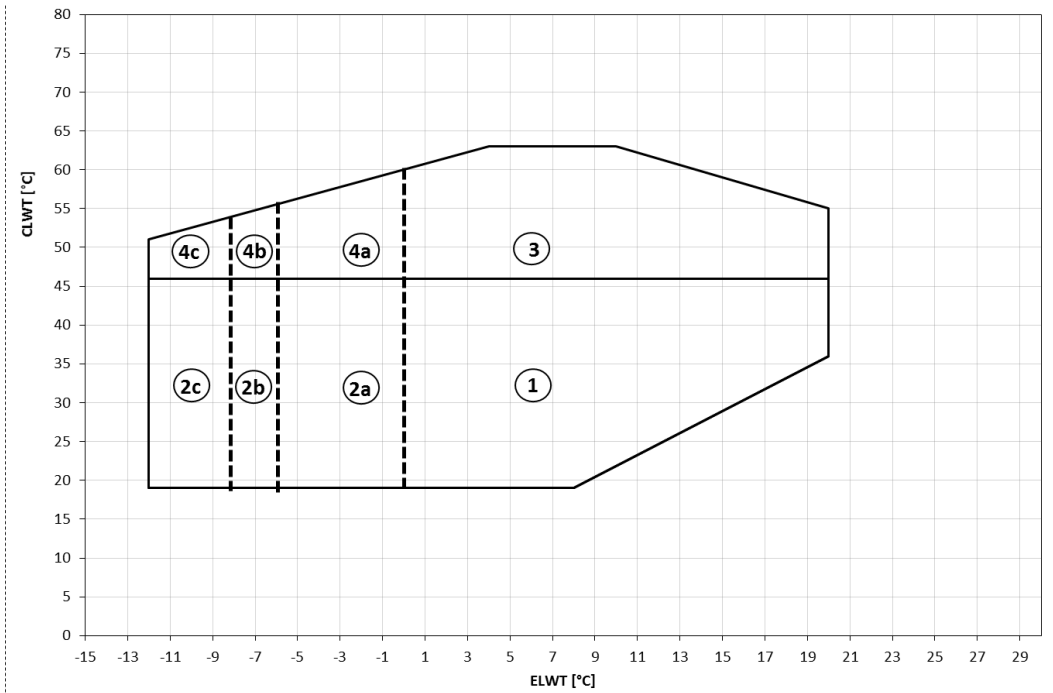

Figure5 - Envelope EWWD_VZ_SS

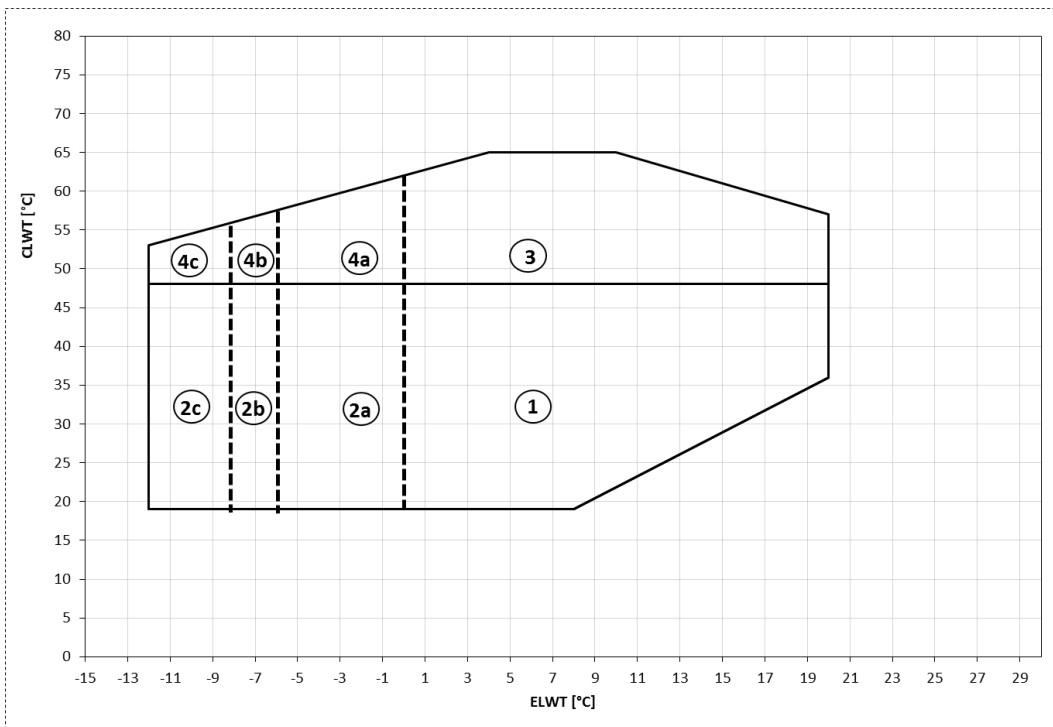

Figure6 - EWWD-VZ-XS/PS

ELWT: Evaporator outlet water temperature

CLWT: Condenser outlet water temperature

Ref.1: standard unit (no options are required to operate in this area)

Ref.2a: standard unit + opt. 08 (Brine). Limit for Propylene Glycol: ELWT = 0 °C

Ref.2b: standard unit + opt. 08 (Brine). Limit for Ethylene Glycol: ELWT = -6 °C

Ref.2c: standard unit + opt. 174 (Low Brine). Limit for Propylene Glycol: ELWT = -8 °C

Ref.3: standard unit + opt. 111 (High temperatures kit).

Ref.4a: standard unit + opt. 08 (Brine) + opt.111 (high temperature kit). Limit for Propylene Glycol: ELWT = -0 °C

Ref.4b: standard unit + opt. 08 (Brine) + opt.111 (high temperature kit). Limit for Ethylene Glycol: ELWT = -6 °C

Ref.4c: standard unit + opt. 174 (Low Brine) + opt.111 (high temperature kit). Limit for Propylene Glycol: ELWT = -8 °C

2.8.2 Operating limits EWWH-VZ

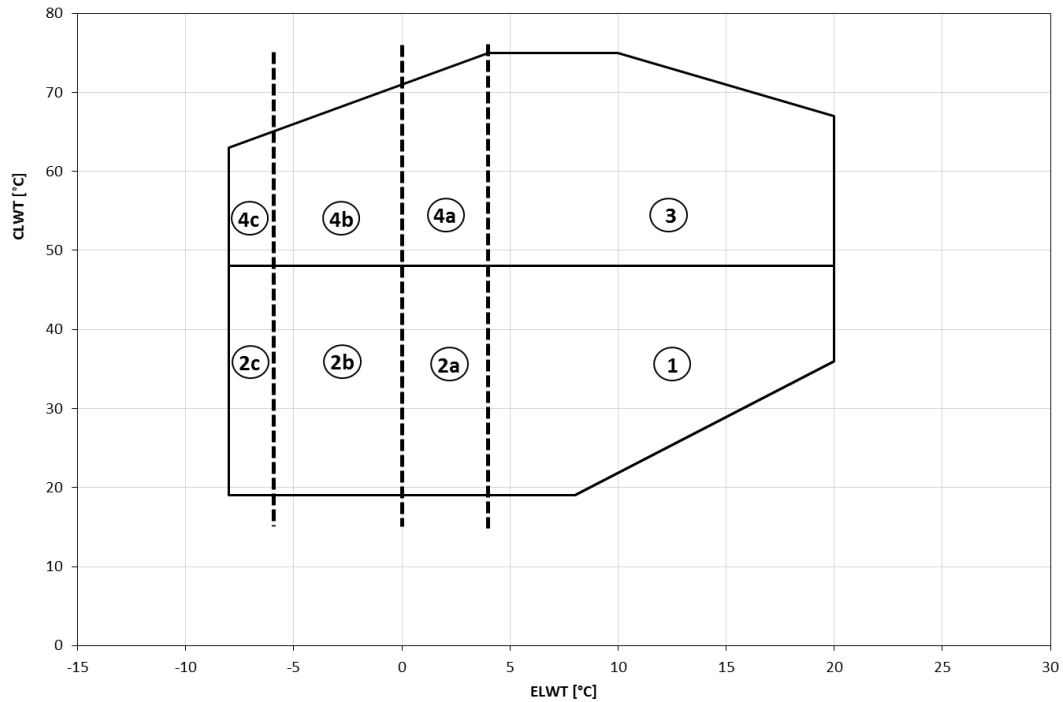

Figure7 - EWWH_VZ_SS

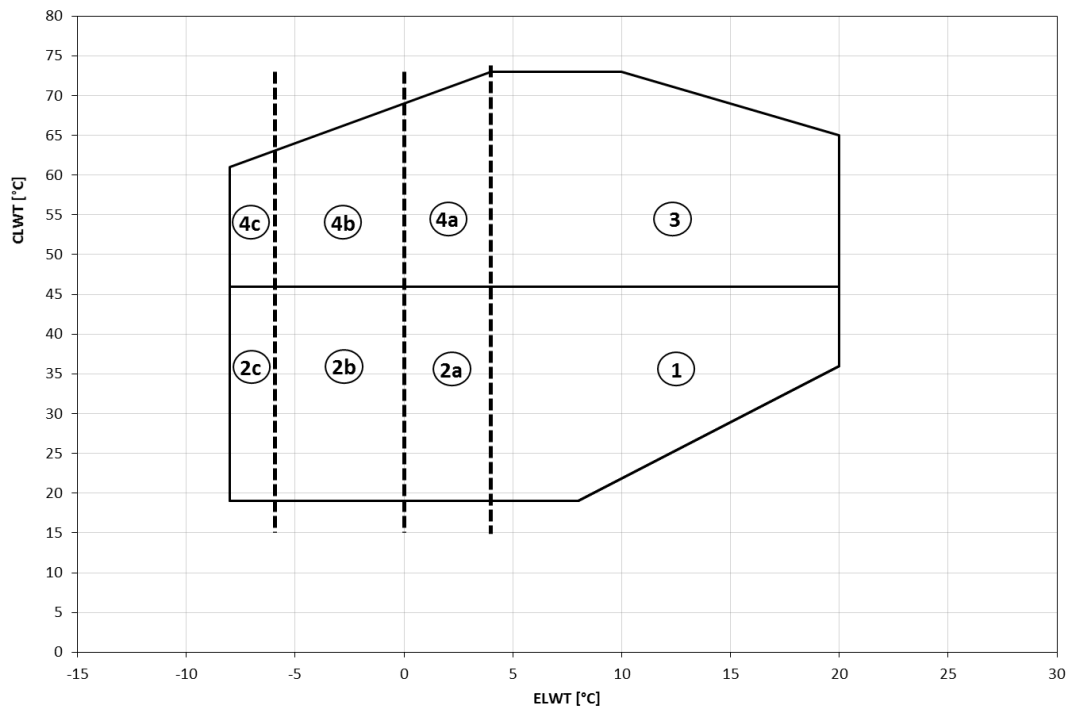

Figure8 - EWWH_VZ_XS

Ref.1: standard unit (no options are required to operate in this area)

Ref.2a: standard unit + opt. 08 (Brine). Limit for Propylene Glycol: ELWT = 0 °C

Ref.2b: standard unit + opt. 08 (Brine). Limit for Ethylene Glycol: ELWT = -6 °C

Ref.2c: standard unit + opt. 174 (Low Brine). Limit for low brine Ethylene Glycol: ELWT = -8 °C

Ref.3: standard unit + opt. 111 (High temperatures kit).

Ref.4a: standard unit + opt. 08 (Brine) + opt.111 (high temperature kit). Limit for Propylene Glycol: ELWT = -0 °C

Ref.4b: standard unit + opt. 08 (Brine) + opt.111 (high temperature kit). Limit for Ethylene Glycol: ELWT = -6 °C

Ref.4c: standard unit + opt. 174 (Low Brine) + opt.111 (high temperature kit). Limit for low brine Ethylene Glycol: ELWT = -8 °C

2.8.3 Operating limits EWWS-VZ

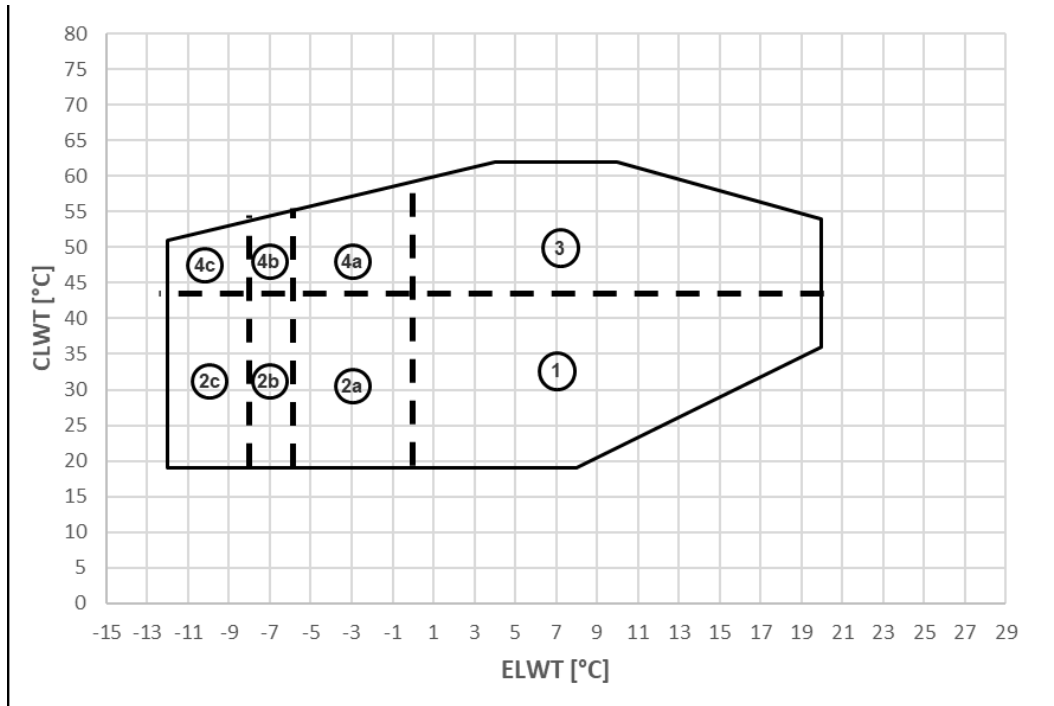

Figure9 - EWWS_VZ_XS/PS

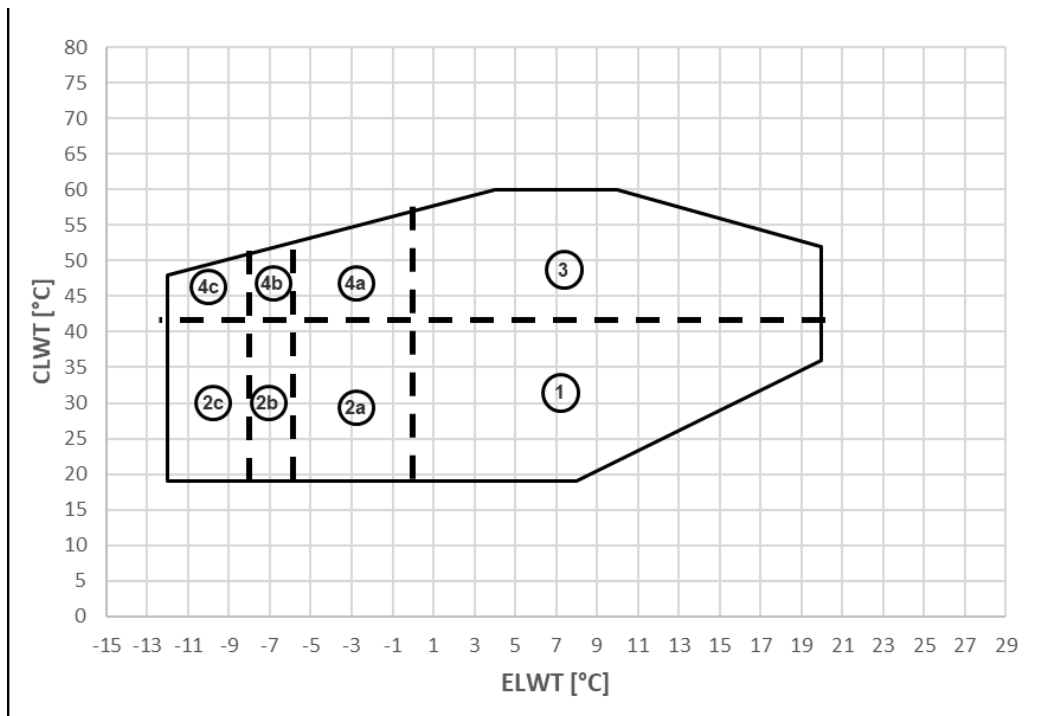

Figure10 - EWWS_VZ_SS

- Ref.1: standard unit (no options are required to operate in this area)
- Ref.2a: standard unit + opt. 08 (Brine). Limit for Propylene Glycol: ELWT = 0 °C
- Ref.2b: standard unit + opt. 08 (Brine). Limit for Ethylene Glycol: ELWT = -6 °C
- Ref.2c: standard unit + opt. 174 (Low Brine). Limit for Propylene Glycol: ELWT = -8 °C
- Ref.3: standard unit + opt. 111 (High temperatures kit).
- Ref.4a: standard unit + opt. 08 (Brine) + opt.111 (high temperature kit). Limit for Propylene Glycol: ELWT = -0 °C
- Ref.4b: standard unit + opt. 08 (Brine) + opt.111 (high temperature kit). Limit for Ethylene Glycol: ELWT = -6 °C
- Ref.4c: standard unit + opt. 174 (Low Brine) + opt.111 (high temperature kit). Limit for Propylene Glycol: ELWT = -8 °C

2.9 Minimum water content in the system

For correct VZ machine operations and the necessary operating stability, it is important to ensure a minimum water content in the system. An accumulation tank with suitable volume may be required for this purpose.

The minimum water content must be calculated by considering the following specifications:

Application	VZ single circuit	VZ Dual circuit
Conditioning	3.3 lt/kW	2.5 lt/kW
Process	6.6 lt/kW	5.0 lt/kW
Variable capacity	6.6 lt/kW	5.0 lt/kW

Calculation example:

Cooling capacity at 100% = 670 kW

Minimum system volume for conditioning: $670 \times 3.3 = 2211$ lt

Minimum system volume for processing: $670 \times 6.6 = 4422$ lt

Minimum system volume at variable capacity: $670 \times 6.6 = 4422$ lt

Note: The calculation formula described above, takes into account several factors such as the compressor stop time and the admissible temperature difference between the last compressor stop and start. In this regard, the minimum water content calculated refers to the machine operations in a normal climate control system. If the machine is used for process activities or if higher operating stability is required, we recommend doubling the calculated water content. In very simple systems, an inertial accumulation tanks may be necessary on the hydraulic circuit to reach the required minimum water volume. Adding this component must guarantee correct water mixing and, therefore, we recommend you select a tank that includes an internal diaphragm for this purpose.

Note: If the evaporator water circuit operates in a variable flow system, the minimum water flow rate must not be less than 50% of the water flow rate at nominal conditions and the variation should not be greater than 10% of the nominal flow per minute.

2.10 Evaporator freeze protection

1. If the machine is idle during the winter, drain and rinse the evaporator and chilled water pipes with glycol. Drain and air vent connections are included on the evaporator for this purpose.
2. We recommend adding glycol in proper proportion to the condenser cooling system. The freezing temperature, of the water-glycol solution, must be at least 6 °C lower than the expected minimum ambient temperature.
3. Insulate pipes especially chilled water ones to avoid condensation.



Damage caused by freezing is not covered by warranty, therefore, Daikin Applied Europe SpA cannot be held liable.

2.11 condenser protection and design considerations

If lake, river or ground water is used as the cooling fluid and the water valves have a leak, the condenser and liquid refrigerant line temperatures could drop under room temperature when the machine is off. This problem occurs when cold water circulates through the condenser and the unit remains off waiting load. If this happens:

1. Turn off the condenser water pump when the compressor is off.
2. Check that the liquid line expansion valve is working properly.

2.11.1 Condensation control with evaporative cooling tower

The minimum condenser inlet water temperature should not be less than 20 °C at full water tower flow rate.

If the water temperature must be lower, even the water flow must be reduced proportionately.

To modulate the water flow to the condenser, install a three-way by-pass valve. The figure shows how the three-way valve is applied to cool the condenser. The three-way valve can be activated by a pressure actuator which guarantees proper condensing pressure in the case where the water temperature entering the condenser is less than 20 °C.

In place of a valve with pressure actuator you might use a three-way servo-operated valve or a circulation pump controlled by an inverter. Both of these two devices may be controlled by an analog 0-10 Vdc signal issued by the machine's electronic controller according to the water temperature entering the condenser.

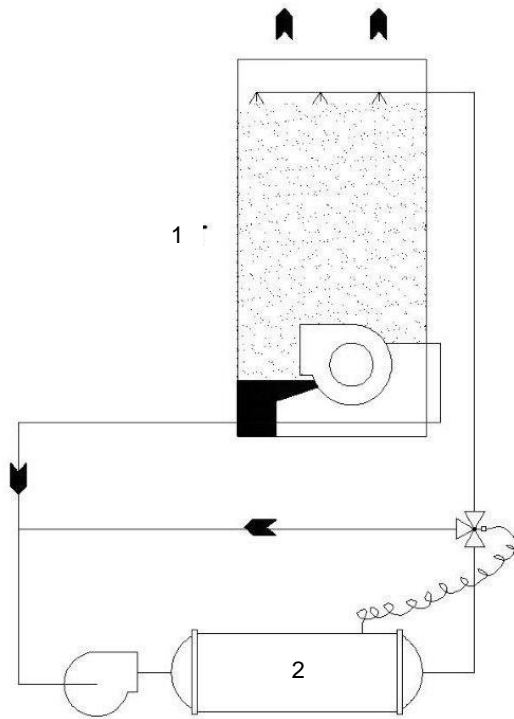

1	Cooling tower
2	Condenser

Figure11 - Condenser control scheme with cooling tower

2.11.2 Condensation control with well water

If ground water is used to cool the condenser, install a normally regulating control valve, direct drive, at condenser outlet. This regulating valve must ensure an adequate condensing pressure in the case where the water temperature entering the condenser is less than 20 °C.

A service valve with pressure outlet is provided on the condenser sleeve for this purpose.

The valve must modulate its opening according to condensing pressure. When the machine shuts down, the valve will close preventing the condenser from emptying.

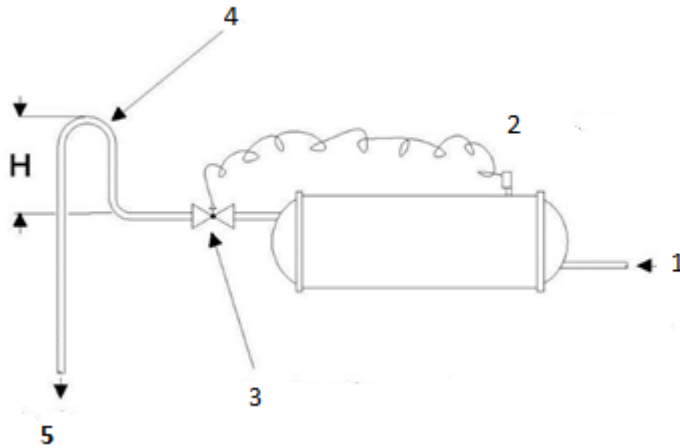

Figure12 - Condensation control scheme with well water

1	From the main condenser pump
2	Service valve
3	Direct acting water regulating valve
4	Configuration required when the regulating valve is not used
5	At Drain

2.12 Chilled water control sensor

The water cooled EWW/D/EWWH/EWWS VZ unit is equipped with a microprocessor. Be careful when working around the unit to avoid damaging cables and sensors. Check cables before starting the unit. Prevent rubbing of the cables on the frame or other components. Make sure the cables are securely locked. If the temperature sensor is removed for maintenance, do not eliminate the conductive paste in the well and replace the sensor correctly. After replacing the sensor, tighten the lock nut to prevent accidental slipping.

2.13 Safety Valve

Each exchanger (evaporator and condenser) is provided with a safety valve installed on a changeover valve that allows maintenance and periodic checks, without losing a significant amount of refrigerant. Do not leave the safety valve in the intermediate position.



To prevent damages due to inhalation and direct contact with refrigerant gas, the safety valve outlets must be connected with a conveyor pipe before operations. These pipes must be installed so that, in case the valve opens, the discharged refrigerant flow not invest people and/or things, or can enter the building through windows and/or other openings. The installer is responsible for connecting the safety valve to the purge pipe and pipe dimensioning. In this regard, refer to the harmonized standard EN13136 to dimension the drain pipes to be connected to the safety valves

2.14 Open the isolation and/or shut off valves

Before powering the machine and thus starting the compressors, open all valves that were closed at the factory for shipping.

The valves to be opened are:

1. Valve (optional) installed on the compressor line.
2. Oil return pipe shutoff valves (jet pump). These valves are positioned below the evaporator sleeve in the vicinity of the jet pump.
3. Liquid line valve installed under the condenser.
4. Oil valves installed on the line that feeds the compressor lubrication system. This line comes from the bottom of the oil separator located inside the condenser.
5. Valve (optional) installed on the compressor pump line.

2.15 Electrical connections

The unit must be connected with in the proper section copper cables relative to the plate absorption values and in accordance with applicable electrical regulations.

Daikin Applied Europe SpA cannot be held liable for improper electrical connections.



***The connections to the terminals must be made with copper terminals and cables.
The electrical connection must be made by qualified personnel.
There is a risk of electric shock***

The electrical panel must be connected keeping the correct phase sequence.

2.16 Phase imbalance

In a three-phase system, excessive imbalance between the phases is the cause of motor overheating. The maximum allowed voltage imbalance is 2%, calculated as follows:

$$\text{Imbalance \%} = \frac{(V_x - V_m) * 100}{V_m}$$

V_x = phase with greatest imbalance

V_m = average of the voltages

I.e. the three phases measure 383, 386 and 392 volts respectively, the average is:

$$\frac{383+386+392}{3} = 387 \text{ V}$$

3

the percentage of imbalance is thus

$$\frac{(392-387)}{387} * 100 = 1,29\% \text{ less than the maximum admitted (2\%)}$$

387



***Before any maintenance and/or electrical connection to the compressor inverter, make sure the system is turned off and the unit main switch open.
After turning off the main switch, wait at least 20 minutes for the inverter condensers to completely discharge. Do not perform any maintenance and/or electrical connection in this period of time.***

2.17 Control circuit

The unit control circuit is powered at 230 Vac.

The controller ON/OFF switch (Q0) must be rotated to the OFF position whenever machine operations are not required.

Water flow switch interlock terminals are included in the controller. See the wiring diagram for the correct connections on the field.

The purpose of the water flow switch interlock is to prevent the compressor from running for enough time to let the two evaporator and condenser water pumps to operate and ensure the correct water flow. The flow switch can be supplied on request from Daikin Applied Europe and in any case must be compulsorily installed on the machine. For better protection against freezing, connecting the evaporator flow switch, contactor clean contact or pump circuit breaker in series.

It is best to leave pump control to the microprocessor for better system management.

If an external system independently manages pump start, follow this logic.

Evaporator water inlet:

- turn on the pump 2 minutes before enabling the machine
- turn off the pump 5 minutes after disabling the machine

Condenser water pumps:

- turn the pump on 30 seconds before enabling the machine
- turn the pump off 1 minute after the last compressor is turned off.

With the machine off, the condenser pump must always be turned off.

Testing the control circuit

Each unit is factory tested. Both the control and power circuits undergo a careful functional test before the machine is shipped.

3 OPERATION

3.1 Operator's responsibilities

It is important that the operator becomes familiar with the equipment before operating the machine.

In addition to reading this manual, the operator should study the operation manual and the wiring diagram supplied with the unit to understand commissioning, operation and the shutdown sequence as well as the shutdown mode and safeties.

During initial machine start-up, the Daikin technician is available to answer any questions and instruct on proper operating procedures.

The operator should keep an operating data log for each specific machine. Furthermore, an additional maintenance log should be kept for periodic maintenance and service.

This Daikin unit represents a substantial investment and deserves the attention and care to keep this equipment in good working order. If the operator observes abnormal or unusual operating conditions, calling Daikin technical service is recommended.

In any case, it is essential to follow the instructions below during operation and maintenance:

- Do not allow unauthorized and/or unskilled personnel to access the unit.
- It is forbidden to access the electrical components without having opened the unit main switch and switched off the power supply.
- It is forbidden to access the electrical components without using an insulating platform. Do not access electrical components if water and/or moisture are present.
- Ensure that all operations on the refrigerant circuit and on components under pressure are exclusively carried out by qualified personnel.
- Compressors must be replaced, and lubricant oil filled by qualified personnel.
- Sharp edges can cause injuries. Avoid direct contact.
- Do not introduce solid objects into the water pipes while the unit is connected to the system.
- A mechanical filter must be fitted to the water pipe connected to the heat exchanger inlet.
- The unit is equipped with high-pressure safety pressure switches on each compressor, which stop it when triggered when the pressure exceeds the set value. If triggered, reset the pressure switches by pressing the blue button and then the alarm on the microprocessor.
- It is absolutely forbidden to remove any protection system covering moving parts.

In case of sudden stop of the unit, follow the instructions on the Control Panel Operating Manual which is part of the on-board documentation delivered to the end user.

It is strongly recommended to perform installation and maintenance with other people.

3.2 Unit description

The machine is made up of a latest generation, high efficiency, new VVR series single screw compressor, flooded shell and tube evaporator with the refrigerant outside the tubes and the water to be cooled flowing inside the tube.

A shell and tube condenser where the refrigerant condenses outside the tubes while the cooling water flows inside of the high-efficiency tubes.

The compressor is of the mono screw semi-hermetic type and utilizes the suction gas coming from the evaporator to cool the motor and permit the optimum operations in all machine load conditions. The compressor, controlled by inverters, changes its cooling load according to the rotational speed decided by the controller. In this way the machine perfectly adapts to system operating conditions to maximize performance.

The oil injection lubrication system, in addition to allowing normal moving part lubrication, also seals the screw ensuring gas compression, without the aid of an external oil pump.

The cooling circuit also installs an electronic expansion valve that, in addition to managing the level of refrigerant in the heat exchangers and guaranteeing the correct operation of the compressor, also manages the PUMP-DOWN function.

All the described components are managed by an innovative microprocessor control system that, by monitoring all the machine operating parameters, optimizes operations.

A diagnostic system helps the operator in identifying alarm and fault causes.



Before starting the compressors ensure that all valves are open and the closing caps are repositioned and tightened.

3.3 Cooling cycle description

The low temperature refrigerant gas coming from the evaporator is sucked by the compressor and flows through the electric motor, cooling it. It is subsequently compressed and during this phase the refrigerant mixes with the oil, injected in the compressor, from the separator.

The high-pressure oil-refrigerant mixture is introduced inside the three-stage high efficiency oil separator which performs the separation. The oil deposited on the bottom of the separator is sent, by pressure difference, to the compressor again while the refrigerant separated from the oil is sent to the condenser.

The refrigerant fluid inside the condenser, which crosses the heat exchanger pipes in countercurrent, de-superheats and starts to condense. The de-superheating heat and condensation is released to the condensation water which heats accordingly.

The condensed fluid at saturation temperature passes through the sub cooling section, where it yields heat to further increase cycle efficiency. The sub cooled fluid flows through the expansion device which, through a pressure drop, initiates the expansion process by vaporizing a part of the refrigerant liquid.

The result at this point is a mixture of liquid and gas at low pressure and temperature, which is introduced into the evaporator.

The liquid-vapor refrigerant after being evenly distributed along the tube bundle exchanges heat with the water to be cooled by reducing the temperature, and it gradually changes state until being fully evaporated.

Reaching the vapor state, it leaves the evaporator to be sucked by compressor again and restart the cycle.

3.3.1 Evaporator

The evaporator is a flooded shell and tube type with water flowing inside the tubes and the gas refrigerant outside. Normally it does not require any maintenance and service. Should a tube require replacement, the old tube can be removed and replaced. The water dome gasket must be replaced after tube cleaning and/or replacement.

3.3.2 Condenser

The condenser is a shell and tube type with water flowing inside the tubes and the refrigerant outside. The condenser tubes are externally finned and expanded on the tube plate. A sub cooler is built into the condenser on all units. Should a tube require replacement, the old tube can be removed and replaced. The water dome gasket must be replaced after tube cleaning and/or replacement.

3.3.3 Expansion valve

The expansion valve is electrically controlled by the electronic controller by means of a specifically designed electronic board. A special algorithm designed for machines with flooded evaporators, manages the refrigerant flow to the evaporator according to machine operating parameters. In the event of blackout, the expansion valve automatically closes thanks to an electric power accumulation system placed inside the electronic control board (supercap)

3.3.4 Compressors

The refrigeration compressor is the single screw type with the rotation shaft directly coupled to the electric motor.

The vapor flows through the electric motor cooling the windings before entering the suction ports. Sensors able to constantly monitor temperature are located inside the motor windings to fully protect the motor against dangerous overheating. The thermistor and power terminals are housed within a terminal box placed above the motor housing.

Moving compressor parts that effect the compression consist of three rotating parts, there are no parts in eccentric or reciprocating movement in the compressor. The essential components are the main rotor and the two side satellites

that perfectly integrate together. The compressor is sealed by a suitably shaped special synthetic material placed between the main rotor and the satellites. The main shaft on which both the motor and the main rotor are installed is supported by three ball bearings. This system is both statically and dynamically balanced before assembly. Two large closing flanges are installed on the sides of the compressor for easy access to the satellites, the rotor, the shaft and the bearings, without which assembly tolerances are influenced with their opening.

3.3.5 Capacity control

The latest generation compressors, installed on EWWH VZ units, are directly controlled by a speed controller with inverter technology. This technology has allowed for the elimination of the shutter trays, improving partial loads performance to a value never reached before. Compressor capacity, therefore, is directly managed by setting the electric motor rotation speed, as a function of a special control algorithm. The compressor rotation speed can vary from a minimum of 840 RPM (14 Hz) to a maximum of 4800 RPM (80 Hz) according to the system operating conditions and the machine model.

Devices were installed instead of slide valve to control the volumetric ratio intrinsic to compression.

3.3.6 Volumetric variable compression ratio (VVR)

The compressor is designed to operate in a very wide operating range and ensure the best possible efficiency in each working condition. In this regard, a sophisticated device dynamically manages the volumetric compression ratio (VVR). This system ensures the optimum position of the discharge ports as a function of the operating compression ratio, choosing one among the four available positions. 3 solenoids are evident on the compressor which, directly connected to the machine controller, are powered according to the operating compression ratio.

3.3.7 Oil management system

Each screw compressor is connected to the device (oil separator) that separates oil from the exhaust gases to collect on the bottom of the device itself.

The exhaust gas pressure pushes the oil into the compressor where, after passing through a high-capacity filter, is sent to the main injection port, maintaining compressing and lubricating moving parts.

The oil, during the compression phase, reunites with the exhaust gas to then be sent back in the separator and restart the cycle.

The oil flow is ensured by the pressure difference that is created between the condenser and the evaporator. This difference is dependent on the cooling water temperature and the evaporator water temperature. Therefore, it is important that the correct temperature difference is rapidly established during the starting phase with an adequate control of the cooling water temperature.

In order to ensure the correct pressure difference, it is necessary to install a condenser inlet water temperature regulation system (three-way valve, inverter on the cooling water pump, etc.) to return the machine operating temperatures within the expected operating range.

On the compressor, after the oil filter, a pressure transmitter is installed that continuously monitors the oil pressure and sends the values to the microprocessor. Oil pressure control protects the compressor from any operating faults. The oil filter must be replaced within the first 500 hours of compressor operations. The electronic controller generates an alarm for high oil differential pressure when 2.5 bar is reached. In this case, replace the oil filter.

The units are already equipped with the correct oil load. Once the system has been started, it is not necessary to add additional oil, except in the event that repairs are carried out or when a large amount of oil has been removed from the system.



Performing incorrect maintenance on the lubrication system, including excessive addition of oil or oil and not suitable to use a different quality oil filter, is harmful to the machine.

3.3.7.1 Lubricant oils

In addition to bearing and moving part lubrication, the oil also has the important function of maintaining compression thus increasing the efficiency.

Contact Daikin Service for approved oil.

3.3.7.2 Liquid injection

EWWH VZ series Daikin units do not require any delivery gas and thus oil cooling system if used within the rated operating range.

In the case where the operating conditions exceed the standard conditions (High Temperature Kit), the compressor requires the oil cooling kit defined as "liquid injection".

This system is directly controlled by the microprocessor installed on the machine, in function of the compressor discharge temperature. Under normal operating conditions and with the compressor off, the solenoid valve that controls liquid injection is off. If the oil temperature exceeds the set point value set in the microprocessor, the system feeds the solenoid valve, by injecting refrigerant liquid into the port designed for this purpose. The oil temperature gradually decreases until reaching the set point less the control differential where the microprocessor de-energizes the solenoid valve. Liquid injection may be activated during system commissioning phases and/or during operation at partial loads.

The liquid injection kit is standard when the "High temperature kit" is required.

3.3.8 Oil recovery system

Each circuit is provided with a system that allows the oil accumulated in the evaporator during normal operation to be recovered.

This system is made up of a "Jet-Pump" which, exploiting the Venturi principle, continuously recovers the oil in circulation in the system that would otherwise accumulate in the evaporator interior due the low speed of the refrigerant gas.

The Jet Pump is fed by the high pressure discharge gas and creates a depression that allows the oil + refrigerant mix to be sucked by the evaporator and conveys it into the compressor to restore the oil level in the lubrication system.

Therefore check:

- 1) oil recovery system valve opening
- 2) Correct solenoid valve operations located at Jet Pump feed

3.3.9 Electrical Control Panel

The unit controller is a microprocessor control panel designed to perform compressor start up step by step, monitor and adjust compressor capacity, protecting it, and perform the shutdown sequence in the absence of load or at a set time. The control panel provides a wide range of data control and registration capacity options. It is important to have good familiarity with the control system for optimal machine operations.

Please note that all units are also provided with the Operating Control Manual.

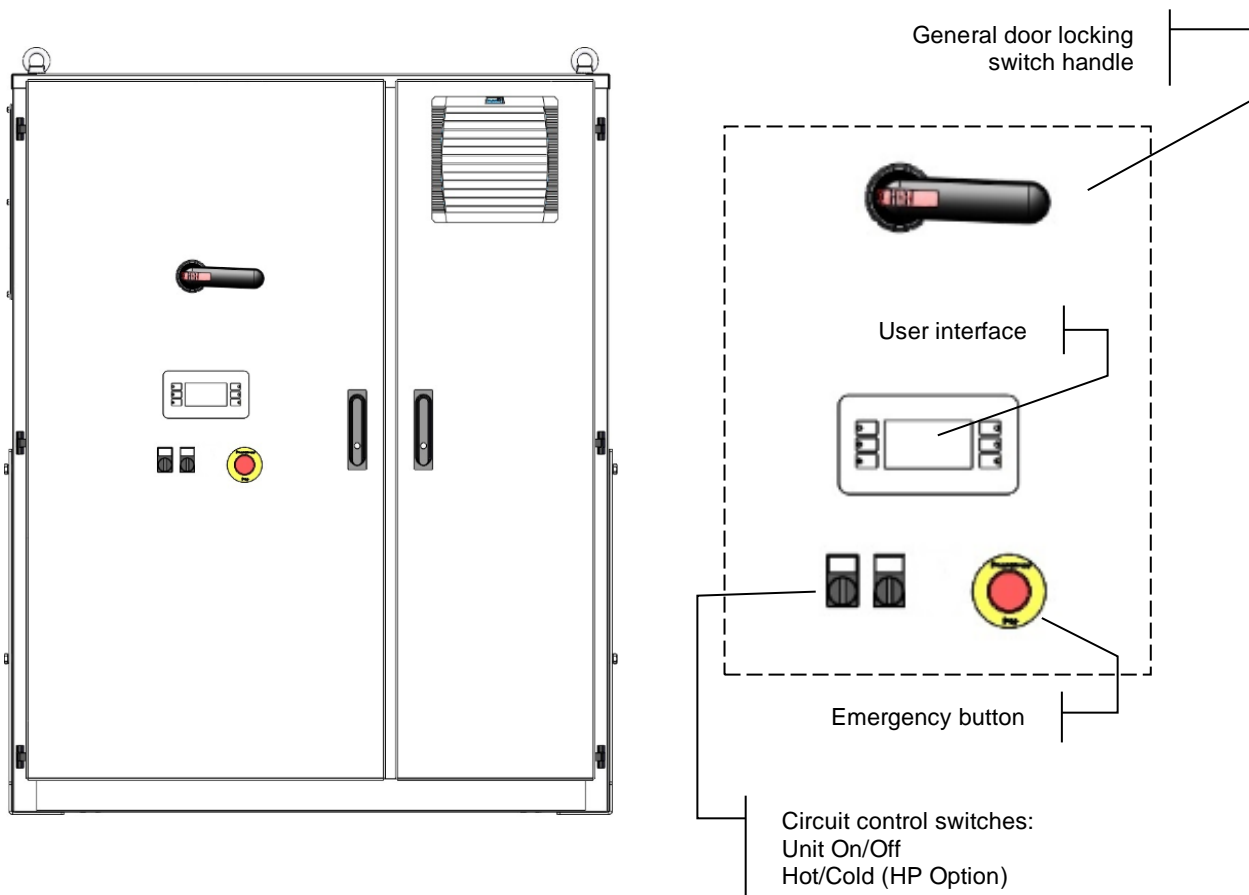

Figure13 - Unit interface

3.3.10 Safeties for each refrigerant circuit

- High pressure (pressure switch)
- Motor cooling
- High compressor delivery temperature
- Compressor suction temperature
- Failed start
- High oil pressure differential
- Low pressure

3.3.11 System safeties

- Antifreeze
- Correct phase sequence and phase failure
- Low pressure (pressure switch)
- Evaporator flow switch

3.3.12 Regulation type

PID regulation (Proportional - Integrative - Derivative on the evaporator sensor for perfect water temperature regulation ($\Delta T = \pm 0.2 \text{ }^\circ\text{C}$).

3.3.13 Compressor alternation

The water-cooled Daikin VZ units alternate the compressor start sequence (VZ dual compressor) to balance the number of starts and operating hours. Compressors are automatically alternated by the controller.

If the unit is in automatic mode, the compressor with the lowest number of starts is started first. If both compressors are in operation and one compressor must be turned off, the one with most hours is switched off.

3.3.14 High pressure condensation control

The microprocessor is provided with a transducer to monitor condensation pressure. Although the main purpose of the high pressure transducer is to maintain proper control of the condensing pressure (by controlling the cooling towers if connected), another purpose is to send a signal to the microprocessor which stops the compressor in case the discharge pressure is excessive. If the unit is switched off for high condensing pressure, the microprocessor must be reset manually.

3.3.15 High pressure mechanical safety pressure switch

The high pressure safety switch is a single pole switch that opens when the pressure exceeds the set limit. The opening of the mechanical safety pressure switch directly triggers the compressor inverter, stopping the IGBT bridge supply. This condition interrupts the compressor power supply inverter output in accordance with EN 60204-1 (stop category 0).

The pressure switch is mounted on the compressor discharge cap.

If the pressure switch triggers, once evaluated and resolved the cause that made it trigger, the alarm can be reset by pressing the blue button on the pressure switch body itself and then resetting the alarm on the microprocessor.

The high-pressure switch can be triggered by:

- a) Lack of water flow to the condenser
- b) Incorrect control of the cooling tower fan and/or of the condenser water temperature control valve (if present).
- c) Wrong measurement of the water temperature in the case of heat pump operation.

3.3.16 Compressor motor protection

The compressor motors are protected against overheating by the use of thermistors inserted on each motor winding. Thanks to these three thermistors, the controller is able to constantly monitor winding temperature and stop the corresponding compressor in the event that the temperature exceeds the safety value.

Repeated interventions of this protection, during normal operation, may indicate a potential problem with the compressor motor or a high suction superheat value due to low refrigerant load. The inverter also has a protective function against overload that stops the corresponding compressor in case of over-absorption. This alarm is manually reset.

4 MAINTENANCE

4.1 Maintenance and repair

Personel working on the electrical or the refrigeration components must be authorized, trained and fully qualified.

Maintenance and repair requiring the assistance of other skilled personnel should be carried out under the supervision of the person competent in the use of flammable refrigerants. Any person conducting servicing or maintenance on a system or associated parts of the equipment should be competent according to EN 13313.

Persons working on refrigerating systems with flammable refrigerants should have competence in safety aspects of flammable refrigerant handling supported by evidence of appropriate training.

Always protect the operating personnel with personal protective equipment appropriate for the tasks to be performed. Common individual devices are helmet, goggles, gloves, caps, safety shoes. Additional individual and group protective equipment should be adopted after an adequate analysis of the specific risks in the area of relevance, according to the activities to be performed.

<p>electrical components</p>	<p>Never work on any electrical components, until the general supply to the unit has been cut using the disconnect switch(es) in the control box. The frequency variators used are equipped with capacitor batteries with a discharge time of 20 minutes; after disconnecting power wait 20 minutes before opening the control box.</p>
<p>refrigerating system</p>	<p>The following precautions should be taken before working on the refrigerant circuit:</p> <ul style="list-style-type: none"> — obtain permit for hot work (if required); — ensure that no flammable materials are stored in the work area and that no ignition sources are present anywhere in the work area; — ensure that suitable fire extinguishing equipment is available; — ensure that the work area is properly ventilated before working on the refrigerant circuit or before welding, brazing or soldering work; — ensure that the leak detection equipment being used is non-sparking, adequately sealed or intrinsically safe; — ensure that all maintenance staff have been instructed. <p>The following procedure should be followed before working on the refrigerant circuit:</p> <p>remove refrigerant (specify the residual pressure); purge circuit with inert gas (e.g. nitrogen); evacuate to a pressure of 0,3 (abs.) bar (or 0,03 MPa); purge again with inert gas (e.g. nitrogen); open the circuit.</p> <p>The area should be checked with an appropriate refrigerant detector prior to and during any hot work to make the technician aware of a potentially flammable atmosphere. If compressors or compressor oils are to be removed, it should be ensured that it has been evacuated to an acceptable level to ensure that there is no flammable refrigerant remaining within the lubricant.</p> <p>Only refrigerant recovery equipment designed for use with flammable refrigerants should be employed.</p> <p>If the national rules or regulations permit the refrigerant to be drained, this should be done safely, using a hose, for example, through which the refrigerant is discharged into the outside atmosphere in a safe area. It should be ensured that an inflammable explosive refrigerant concentration cannot occur in the vicinity of an ignition source or penetrate into a building under any circumstance.</p> <p>In the case of refrigerating systems with an indirect system, the heat-transfer fluid should be checked for the possible presence of refrigerant.</p> <p>After any repair work, the safety devices, for example refrigerant detectors and mechanical ventilation systems, should be checked and the results recorded.</p> <p>It should be ensured that any missing or illegible label on components of the refrigerant circuit is replaced.</p> <p>Sources of ignition should not be used when searching for a refrigerant leak.</p>

4.2 Pressure/Temperature Table

HFC-134a Pressure/Temperature Table							
°C	Bar	°C	Bar	°C	Bar	°C	Bar
-14	0,71	12	3,43	38	8,63	64	17,47
-12	0,85	14	3,73	40	9,17	66	18,34
-10	1,01	16	4,04	42	9,72	68	19,24
-8	1,17	18	4,37	44	10,3	70	20,17
-6	1,34	20	4,72	46	10,9	72	21,13
-4	1,53	22	5,08	48	11,53	74	22,13
-2	1,72	24	5,46	50	12,18	76	23,16
0	1,93	26	5,85	52	13,85	78	24,23
2	2,15	28	6,27	54	13,56	80	25,33
4	2,38	30	6,7	56	14,28	82	26,48
6	2,62	32	7,15	58	15,04	84	27,66
8	2,88	34	7,63	60	15,82	86	28,88
10	3,15	36	8,12	62	16,63	88	30,14

HFO-R1234ze(E) Pressure/ Temperature conversion table									
°C	kPa	°C	kPa	°C	kPa	°C	kPa	°C	kPa
-15	20	4	150	23	369	43	731	62	1239
-14	25	5	159	25	399	44	754	63	1271
-13	30	6	169	26	414	45	776	64	1304
-12	36	7	178	27	430	46	800	65	1337
-11	42	8	188	28	445	47	823	66	1370
-10	47	9	198	29	462	48	848	67	1405
-9	53	10	208	30	478	49	872	68	1440
-8	60	11	219	31	496	50	898	69	1475
-7	66	12	230	32	513	51	923	70	1511
-6	73	13	241	33	531	52	949	71	1548
-5	79	14	252	34	549	53	976	72	1585
-4	86	15	264	35	568	54	1003	73	1623
-3	94	16	276	36	587	55	1031	74	1662
-2	101	17	289	37	606	56	1059	75	1701
-1	109	18	301	38	626	57	1088	76	1741
0	117	19	314	39	646	58	1117	77	1782
1	125	20	327	40	667	59	1147	78	1823
2	133	21	341	41	688	60	1177	79	1865
3	141	22	355	42	709	61	1208	80	1908

HFC-R513A Pressure/ Temperature conversion table							
°C	Bar	°C	Bar	°C	Bar	°C	Bar
-14	0.93	12	3.80	38	9.13	64	17.99
-12	1.08	14	4.11	40	9.67	66	18.86
-10	1.25	16	4.44	42	10.23	68	19.75
-8	1.42	18	4.78	44	10.82	70	20.68
-6	1.61	20	5.13	46	11.42	72	21.64
-4	1.80	22	5.51	48	12.05	74	22.63
-2	2.01	24	5.89	50	12.70	76	23.65
0	2.23	26	6.30	52	13.38	78	24.71
2	2.46	28	6.73	54	14.08	80	25.82
4	2.70	30	7.17	56	14.81	82	26.94
6	2.96	32	7.63	58	15.57	84	28.11
8	3.22	34	8.11	60	16.35	86	29.32
10	3.51	36	8.61	62	17.16	88	30.58

4.3 Routine maintenance

4.3.1 Check condenser performance

It is important to periodically check the internal cleanliness of the copper tubes, in order to prevent deteriorated performance. This check can be carried out by checking that the difference between the condensation temperature and the condenser outlet water temperature on the microprocessor does not exceed 3-5 °C (3 °C version XS and 5 °C for the SS version). If deviations from this value occur, run the specific cleaning procedure.

4.3.2 Electronic expansion valve

The units are equipped with one or two electronic expansion valves according to the number of compressors installed on the machine. The valves are managed and controlled by the main electronic controller that optimizes the flow of refrigerant gas to the evaporator according to machine operating conditions. The valve control logic prevents, together with compressor load control, machine operations beyond the allowed operation limits. Normally, no maintenance is required for this device.

4.3.3 Cooling circuit

Cooling circuit maintenance consists of recording operating conditions and making sure the unit has the correct amount of oil and refrigerant. (See the maintenance schedule and appropriate operating data at the end of this bulletin). Record the following for each circuit upon inspection:

Delivery pressure, discharge temperature, suction pressure, suction temperature, oil pressure, liquid temperature, evaporator inlet/outlet water temperature, condenser inlet/outlet water temperature, absorbed current, power voltage, compressor operating frequency.

Significant discharge sub cooling and/or superheating value changes, can be a symptom of low refrigerant load. The correct unit delivery superheating value of the unit at full load must be between 8 and 15 °C, while sub cooling must be between 3.5 and 6.0 °C (machine at full load).

4.3.4 Delivery and suction valves (optional)

If the valve remains in the same position for a long time, it is recommended to close and open the valve repeatedly at least 4 times per year.

Figure14 - Typical single circuit cooling circuit

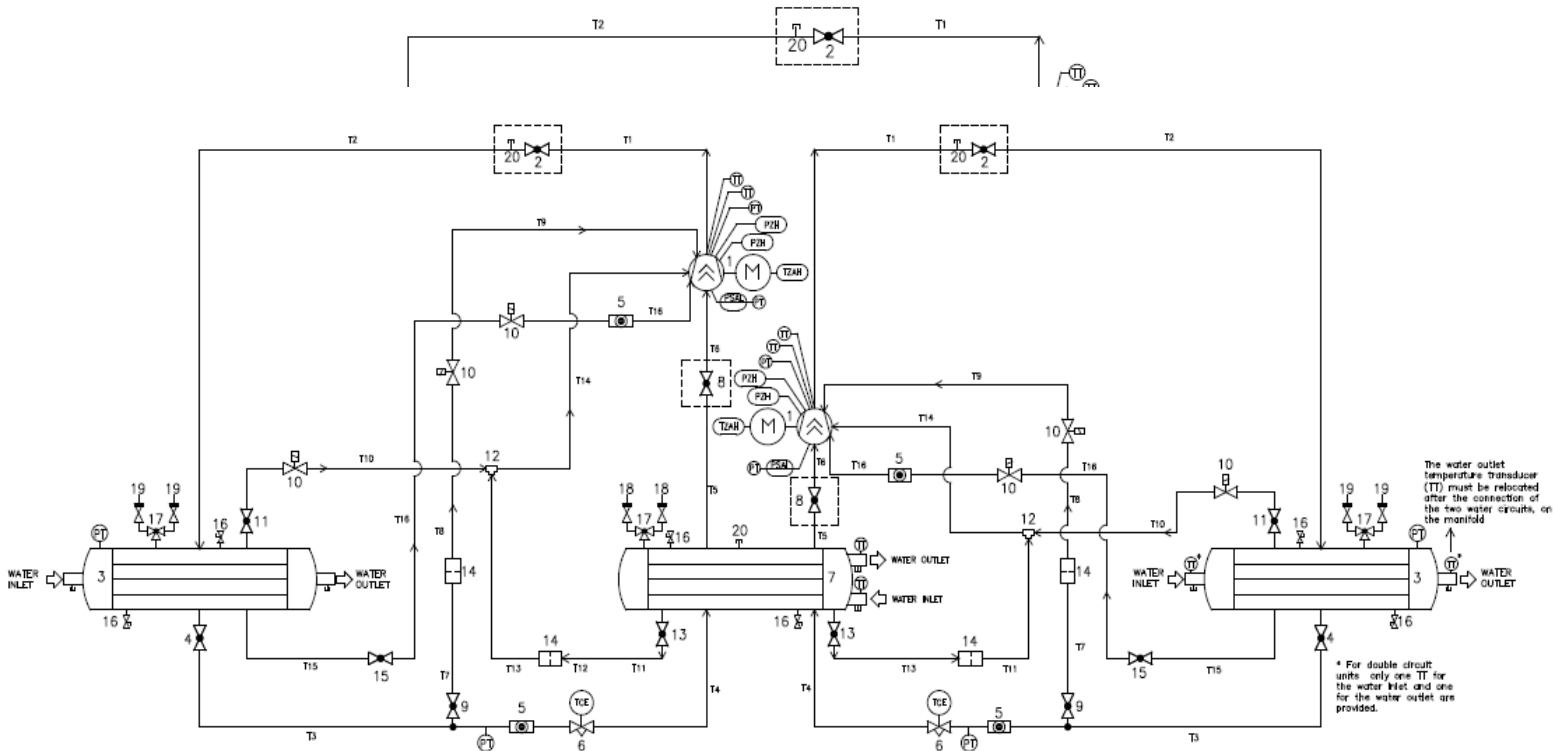

Figure15 - Typical dual circuit cooling circuit

Legend

1	Compressor	19	Pressure relief valve 22,0 bar
2	Discharge valve	20	Access fitting
3	Condenser	T1	Compressor-discharge valve
4	Shut-off device	T2	Discharge valve-condenser
5	Liquid indicator	T3	Condenser-expansion valve
6	Expansion valve	T4	Expansion valve-evaporator
7	Evaporator	T5	Evaporator-suction valve
8	Suction valve	T6	Suction valve-compressor
9	Shut-off device	T7	Shut-off device-strainer
10	Solenoid valve	T8	Strainer-solenoid valve
11	Shut-off valve	T9	Solenoid valve-compressor
12	Jet pump	T10	Thermoplastic pipe
13	Shut-off valve	T11	Shut-off device-strainer
14	Strainer	T13	Strainer-jet pump
15	Shut-off valve	T14	Jet-pump compressor
16	Valve access fitting	T15	Shut-off valve-solenoid valve
17	Changeover device	T16	Solenoid valve-compressor
18	Pressure relief valve 16,0 bar		

ID	DESCRIPTION
PT	Pressure transducer
PZH	High-pressure switch
TZAH	High temperature switch (Motor thermistor)
PSAL	Low pressure limiter (controller function)
TT	Temperature transducer

4.3.5 Refrigerant charge

The EWWD/EWWH/EWWS VZ units are designed to operate with R134a/R1234ze(E)/R513A refrigerant therefore DO NOT USE other refrigerants.



When you add or remove refrigerant gas, always ensure correct water flow in the evaporator and the condenser to avoid freezing pipes.

Freeze damage will void the warranty.

The removal of refrigerant and drainage operations has to be made by qualified technicians with the use of appropriate material for the unit. Improper maintenance can lead to uncontrolled loss of pressure and fluid. Also does not pollute the environment with refrigerant and lubricant oil. Always use an appropriate waste disposal system.

All units are shipped with a full refrigerant charge. If the unit needs to be recharged in the field, follow these recommendations. The optimum charge is one that allows the unit to operate with a correct flow of refrigerant in all conditions.

4.3.5.1 Check the refrigerant charge

To check whether the unit is operating with the correct refrigerant charge, you should check the following:

1. Bring the machine to maximum load conditions
2. Ensure that the evaporator outlet water temperature is in the range of 6 to 8 °C.
3. Verify that the condenser inlet water temperature is between 25 and 32 °C.
4. Under the conditions described above, check that:
 - a) Delivery superheating is between 8(for R134a)/5(for R1234ze/R513A) and 15 °C.
 - b) Sub cooling is between 4 and 6 °C. Liquid sight glass should not flashes.
 - c) The temperature difference between outlet water and evaporation is comprised between 0.5 and 4 °C.
 - d) The difference between condensing temperature and condenser outlet water temperature is between 1 and 3 °C.
5. Make sure the indicator on the liquid tube is full.

If one of these parameters exceeds the indicated limits, the machine may require additional refrigerant.

NOTE

As the unit changes the load, the sub cooling value varies, but will stabilize in a short period of time and in any case should never be less than 3 °C. The sub cooling value slightly varies as evaporator and condenser outlet water temperature varies.

A loss of refrigerant can be so small as to have little effect on the circuit, or may be so obvious as to cause the machine to shutdown triggered by safety protections.

4.3.6 Electrical Installation

The electrical installation involves the application of some general rules as described below:

1. The current absorbed by the compressor must be compared with the nameplate value. Normally, the absorbed current value is less than the nameplate value that corresponds to compressor absorption at full load at maximum operating conditions.
2. At least once every three months all the safety checks should be made to intervene to check its functionality. Each unit, with aging, can change its operating point and this should be monitored to possibly fix or replace it. Pump interlocks and flow switches should be checked to make sure that they interrupt the control circuit when triggered. The high-pressure switches must be checked on the bench separately.
3. The compressor motor ground resistance must be checked every six months. This checks insulation deterioration. A resistance of less than 50 ohms indicates a possible defect in insulation or moisture in the circuit that must be checked.



***Never measure the motor resistance while it is empty.
It may cause serious damage.***

4.4 Cleaning and Storage

A common cause of the equipment failure and subsequent service call is dirt. This can be prevented with regular maintenance. System components more prone to dirt are:

1. Clean the electrical panel ventilation and cooling filters, make sure ventilation correctly starts on the electrical panel.
2. Remove and clean the filters in the chilled water system, in the cooling water system at each inspection.

4.5 Seasonal maintenance

Before you turn off the unit for a long period of time and starting it again, proceed as follows:



Shut-off valves must be turned at least once a year in order to preserve their function.

4.5.1 Seasonal shutdown

1. Where the unit may be subject to freezing temperatures, the condenser and the cooling water pipes must be disconnected and drained of all water. Blow dry air through the condenser; this operation will help to eliminate all water. Both the condenser that the evaporator is not self-draining. If water remains in the pipes and the heat exchanger, these can be damaged in case of freezing.

The forced circulation of the antifreeze solution through the water circuit is a sure way to eliminate the risk of freezing.

2. Care should be taken to prevent the accidental opening of the water circuit shut-off valves.
3. If you are using a cooling tower and if the water pump is exposed to freezing temperatures, remove the pump drain plug to prevent the accumulation of water.
4. Open the compressor switch and remove the fuses. Set the 1/0 manual switch to 0.
5. To avoid corrosion, clean and paint rusted surfaces.
6. Clean and drain the water tower on all units operating with a tower. Make sure tower emptying is effective. Follow a good maintenance program to prevent the formation of lime scale deposits both in the tower in the condenser. Take into account that the atmospheric air contains many contaminants that increase the need of proper water purification. The use of untreated water can result in corrosion, erosion, fouling or the formation of algae. We recommend you contact an expert for reliable water purification.
7. Remove the condenser heads at least once a year to inspect the pipes and clean if necessary.



Daikin Applied Europe SpA cannot be held liable for damage caused by untreated or improperly treated water.

4.5.2 Seasonal start up

Annual start up is a good time to assess motor winding ground resistance. A semi-annual check and recording the resistance value measured keeps track of insulation deterioration. All new units have a resistance over 100 Mega Ohm between each motor terminal and grounding.

1. Check and tighten all electrical connections.
2. The control circuit must be switched off for the entire time.
3. Replace the cooling tower pump drain plug if it was removed during previous season shutdown.
4. Install the main fuses (if removed).
5. Reconnect water lines and refill the circuit. Purge the condenser and check for leaks.

5 SERVICE SCHEDULE

It is important that all systems receive adequate maintenance. The entire system benefits if the system is in good conditions.

The maintenance program must be continuous from first system start: Full inspection must be made after three or four weeks of normal operation and continue regularly.

Daikin Applied Europe offers a variety of maintenance services through its local Daikin service departments and through a worldwide service organization and can adapt their services to the customer's needs.

For more information on service availability, contact your Daikin service department.

6 MAINTENANCE SCHEDULE

	Monthly	Quarterly	Semi-annually	Annually	As Required By Performance
A. Performance evaluation	O				
B. Motor					
• Winding insulation			X		
• Current balance (within 10%)		X			
• Terminals check (tork, cleaning)				X	
C. Lubrication system					
• Oil line temperature	O				
• Oil solenoid operation		X			
• Oil Analysis				X (a)	
• Oil appearance (color and quantity)	O				
• Oil filter change					X (b)
• Oil (+ filter) replacement (after proper analisys)					X
D. VVR operation					
Loading VVR: Check motor current and record		X			
Unload VVR: Check motor current and record		X			
II. Controller					
A. Controller operation					
• Check settings and operation			X		
• Check unload operation			X		
• Check of load balancing			X		
B. Safety check					
Operating test of:					
• Alarm output		X			
• Water pumps interlock		X			
• High and low pressure operation		X			
• High discharge temperature cut-out		X			
• High differential oil pressure		X			
III. Condenser					
A. Capacity evaluation (°)	O				
B. Water quality analisys		X			
C. Condenser tube cleaning					X (d)
E. Seasonal Protection (e.g. antifreeze)					X
IV. Evaporator					
A. Capacity evaluation	O				
B. Water quality analisys		X			
C. Evaporator tube cleaning (when required)					X
E. Seasonal Protection (e.g. antifreeze)					X
V. Expansion valves					
A. Operating check		X			

Legend:

O = Carried out by customer staff; X = Carried out by Daikin rrepresentative technical staff

Note

(a) Oil Analysis have to be performed each year or every 5000 hours of operation, whichever shall first occur.

(b) Change the oil filter if $\Delta p > 2$ bar

(c) Check water temperature entering and leaving the condenser

(d) If the approach is > 5 °C

	Monthly	Quarterly	Semi-annually	Annually	As Required By Performance
VI. Unit					
A. Capacity assessment	O				
B. Leak test					X ^(e)
C. Vibration Test		X			
D. General items:					
• Painting				X ^(f)	
• Thermal Insulation				X ^(f)	
VII. Frequency Driver					
A. Check operation		X			
B. Electrical connections		X			
C. Clean driver heat sink		X			
VIII. Optional checks for HT version only					
Liquid injection checks		X			

Legend:

O = Carried out by customer staff; X = Carried out by Daikin representative technical staff

Note

(^e) According to F-gas Regulation and local rules

(^f) In aggressive environment increase the frequency

NOTE

The compressors are connected to the variable frequency driver. Disconnect the cable to the driver for proper insulation measurement. This test must be done from specialized technical personnel.

7 PRECOMMISSIONING CHECK LIST

Job Name: _____

Unit Model No.(s): _____

Daikin Serial Unit No.: _____

Chilled Water	Yes	No	N/A
- Piping complete	<input type="checkbox"/>	<input type="checkbox"/>	<input type="checkbox"/>
- Water System flushed, filled and vented	<input type="checkbox"/>	<input type="checkbox"/>	<input type="checkbox"/>
- Pumps installed & operational (rotation checked)	<input type="checkbox"/>	<input type="checkbox"/>	<input type="checkbox"/>
- Strainers installed and clean	<input type="checkbox"/>	<input type="checkbox"/>	<input type="checkbox"/>
- Controls (3-way valves, bypass valves, damper, etc.) operable	<input type="checkbox"/>	<input type="checkbox"/>	<input type="checkbox"/>
- Flow switch installed	<input type="checkbox"/>	<input type="checkbox"/>	<input type="checkbox"/>
- Water system operated and flow balanced to meet unit design requirements	<input type="checkbox"/>	<input type="checkbox"/>	<input type="checkbox"/>
- Proper glycol percentage for the application in accordance with Daikin specifications	<input type="checkbox"/>	<input type="checkbox"/>	<input type="checkbox"/>
Condenser Water			
- Cooling tower flushed, filled and piping vented	<input type="checkbox"/>	<input type="checkbox"/>	<input type="checkbox"/>
- Pumps installed & operational (rotation checked)	<input type="checkbox"/>	<input type="checkbox"/>	<input type="checkbox"/>
- Strainers installed and clean	<input type="checkbox"/>	<input type="checkbox"/>	<input type="checkbox"/>
- Controls (3-way valves, bypass valves, etc.) operable	<input type="checkbox"/>	<input type="checkbox"/>	<input type="checkbox"/>
- Water system operated and flow balanced to meet unit design requirements	<input type="checkbox"/>	<input type="checkbox"/>	<input type="checkbox"/>
- Proper glycol percentage for the application in accordance with Daikin specifications	<input type="checkbox"/>	<input type="checkbox"/>	<input type="checkbox"/>
Electrical			
- Power leads connected to unit main terminal block	<input type="checkbox"/>	<input type="checkbox"/>	<input type="checkbox"/>
- Power leads have been checked for proper electrical phasing U-V-W for L1, L2, & L3 respectively	<input type="checkbox"/>	<input type="checkbox"/>	<input type="checkbox"/>
- All interlock wiring complete and complies with Daikin specifications	<input type="checkbox"/>	<input type="checkbox"/>	<input type="checkbox"/>
- Pumps starter and interlocks wired	<input type="checkbox"/>	<input type="checkbox"/>	<input type="checkbox"/>
- Cooling tower fans and controls wired	<input type="checkbox"/>	<input type="checkbox"/>	<input type="checkbox"/>
- Wiring complies with National Electrical Code and local codes	<input type="checkbox"/>	<input type="checkbox"/>	<input type="checkbox"/>

Miscellaneous			
- Unit installed in accordance with Daikin IOM specifications (leveling, space requirements,...)	<input type="checkbox"/>	<input type="checkbox"/>	<input type="checkbox"/>
- Thermometer wells, thermometers, gauges, control wells, controls, etc., installed	<input type="checkbox"/>	<input type="checkbox"/>	<input type="checkbox"/>
- A minimum system load of 60% of machine capacity is available for testing and adjusting controls	<input type="checkbox"/>	<input type="checkbox"/>	<input type="checkbox"/>

Warning: Under no condition should these units be started prior to the authorized start-up by Daikin Applied. Failure to follow this warning may result in serious equipment damage and will negate the warranty.

All installation work has been completed as checked above; the system has been inspected and the unit is ready for start-up

Site Engineer

Name: _____

Date: _____

Signature: _____

Daikin Applied Europe S.p.A.

Servicesupport@daikinapplied.eu

8 IMPORTANT INFORMATION REGARDING THE REFRIGERANT USED

This product contains fluorinated greenhouse gases. Do not vent gases into the atmosphere.

Refrigerant type: R134a / R1234ze/R513A
 GWP(1) value: 1430 / 7/ 572
 (1)GWP = global warming potential

8.1 Factory and Field charged units instructions

The refrigerant system will be charged with fluorinated greenhouse gases, and the factory charge(s) are recorded on the label, shown below, which is adhered inside the electrical panel.

Periodic inspections for refrigerant leaks may be required depending on European or local legislation.

Please contact your local dealer for more information.

1 Fill in with indelible ink the refrigerant charge label supplied with the product as following instructions:

- any refrigerant charge for each circuit (1; 2; 3) added during commissioning
- the total refrigerant charge (1 + 2 + 3)
- **calculate the greenhouse gas emission with the following formula:**

$$GWP \text{ value} * \text{total refrigerant charge [kg]}/1000$$

(Use the GWP value mentioned on the greenhouse gases label. This GWP value is based on the 4th IPCC Assessment Report)

The diagram shows a rectangular label with the following elements:

- Top left: Warning icon and text "Contains fluorinated greenhouse gases" (labeled 'a').
- Top center: Refrigerant type "R1234ze" (labeled 'm') and "GWP: 7" (labeled 'n').
- Top right: Serial number "CH-XXXXXXXX-KKKKXX" (labeled 'p').
- Center: A table for recording charges:

	Factory charge (c)	Field charge (d)	kg
1 =	[]	[]	kg
2 =	[]	[]	kg
3 =	[]	[]	kg
<hr/>			
1 + 2 + 3 =	[]	[]	kg
Total refrigerant charge	[]		kg
Factory + Field	[]		kg
GWP x kg/1000	[]		tCO ₂ eq

- a Contains fluorinated greenhouse gases
- b Circuit number
- c Factory charge
- d Field charge
- e Refrigerant charge for each circuit (according to the number of circuits)
- f Total refrigerant charge
- g Total refrigerant charge (Factory + Field)
- h **Greenhouse gas emission** of the total refrigerant charge expressed as tonnes of CO₂ equivalent
- m Refrigerant type
- n GWP = Global Warming Potential
- p Unit serial number



In Europe, the greenhouse gas emission of the total refrigerant charge in the system (expressed as tonnes CO₂ equivalent) is used to determine the maintenance intervals. Follow the applicable legislation.

9 PERIODIC CHECKS AND COMMISSIONING OF PRESSURE VESSELS

The units described in this manual fall under category IV of the classification determined by the European Directive 2014/68 / EU (PED). For chillers in that category some local regulations require a periodic inspection by an authorized agency.

Please verify and contact these organizations to also request authorization to start it up.

10 DEMOLITION AND DISPOSAL

The unit is made up of metal, plastic and electronic components. All these components must be disposed of in accordance with local laws regarding disposal and, if in scope, with the national laws implementing the Directive 2012/19/EU (RAEE).

Batteries and electrical components must be sent to specific waste collection centres.

Prevent refrigerant gases from polluting the environment using suitable pressure vessels and means to transfer the pressurized fluid. This operation must be carried out by personnel trained in refrigeration plants and in accordance with applicable laws of the country of installation.

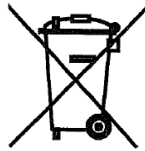

For more information email info@daikinapplied.uk or visit www.daikinapplied.uk

For all Daikin Applied UK,
Daikin Applied Service &
Spares enquiries call us on:
0345 565 2700



Daikin Europe N.V. participates in the Eurovent Certified Performance programme for Liquid Chilling Packages and Hydronic Heat Pumps, Fan Coil Units and Variable Refrigerant Flow systems. Check ongoing validity of certificate:
www.eurovent-certification.com

The present publication is drawn up by way of information only and does not constitute an offer binding upon Daikin Europe N.V. Daikin Europe N.V. has compiled the content of this publication to the best of its knowledge. No express or implied warranty is given for the completeness, accuracy, reliability or fitness for particular purpose of its content and the products and services presented therein. Specifications are subject to change without prior notice. Daikin Europe N.V. explicitly rejects any liability for any direct or indirect damage, in the broadest sense, arising from or related to the use and/or interpretation of this publication. All content is copyrighted by Daikin Europe N.V.

