

EWWH VZ

Water cooled inverter
screw chillers

Product manual

Nominal capacity range: 330 - 1540 kW
Best performances at full load and part loads
Full flexibility with 3 efficiency versions
Low noise option
Designed for wide application range and compact footprint

Refrigerant: R1234ze
Performance according to EN14511-1 (2013)

Code	WEB CSS
Date	November 2018
WATERFL2C	R1.0.0

Table of content

EWWH-VZ

Features and benefits		2	Operating limits	
General characteristics		4	Operating envelope	27
			Water charge, flow, quality	30
Nomenclature		8	Dimensional drawings	31
Options			Installation notes	34
Standard options		9	Technical specification	35
Mechanical options		10		
Electrical options		12		
Installation and other options		13		
Technical specifications performance data				
Silver series				
EWWH VZ SS		14		
Gold series				
EWWH VZ XS		16		
Platinum series				
EWWH VZ PS		19		
Electrical specifications				
Silver series				
EWWH VZ SS		20		
Gold series				
EWWH VZ XS		21		
Platinum series				
EWWH VZ PS		23		
Sound levels				
Silver series				
EWWH VZ SS		24		
Gold series				
EWWH VZ XS		25		
Platinum series				
EWWH VZ PS		26		

Features and Benefits

Low operating cost High Flexibility and Reliability. The EWWH~VZ A is the result of careful design, aimed to optimize the energy efficiency of the chiller and with the clear target to reduce operating costs. The chiller series features Daikin design single screw compressor driven by inverter. Heat exchangers are flooded type for optimized heat transfer.

The EWWH~VZ A range is available with 3 different efficiency versions:

- EWWH~VZ A SS "SILVER": average EER 5,09 (up to 5,35) and average ESEER 8,07 (up to 8,48)
- EWWH~VZ A XS "GOLD": average EER 5,31 (up to 5,53) and average ESEER 8,31 (up to 8,81)
- EWWH~VZ A PS "PLATINUM": average EER 5,48 (up to 5,71) and average ESEER 8,63 (up to 8,9)

Those three efficiency levels can be combined with numerous options resulting in several different available configurations.

Leading class efficiency. The EWWH~VZ A series is designed to achieve leading class efficiency at both full load and part load operations.

Compactness. The EWWH~VZ A series is designed to achieve the smallest possible footprint making the product the ideal solution to fit through the tightest doorways and consequently the perfect product for replacement projects.

Application flexibility. The EWWH~VZ A series can satisfy a large variety of applications not limited to traditional comfort cooling but also data centers, brine water, ice storage and high temperature heat pump (up to 65°C).

Outstanding reliability. EWWH~VZ A series features one or two independent refrigerant circuits in order to guarantee highest possible redundancy and simplified maintenance activities. Units are equipped with rugged compressor design with advanced and robust composite compressor gate-rotors material. Units are factory tested before shipment for an on-site trouble free operation.

Stepless capacity control. Cooling capacity is controlled by means of inverter driving the compressor motor. Units are enjoying infinitely variable capacity control from 100% load down to minimum capacity which is variable depending on unit model. No any mechanical unloading system is used. This advanced capacity control method allows the unit to perfectly match the cooling (or heating) load and consequently providing extremely accurate water temperature control.

Variable Volume Ratio. Compressors are enjoying the Variable Volume Ratio (VVR) technology. This innovative system allows the compressor to adapt the discharge pressure of the refrigerant to the specific operating conditions. In this way, it is possible to prevent energy losses deriving from under or over compression phenomena that are typical of traditional compressor technologies (with fixed volume ratio). The reduction of energy losses inside compressor brings to an increased unit efficiency.

Ecological solution. Daikin EWWH~VZ is the best answer to both Ecodesign and F-GAS regulation with highest efficiency levels in the market and now also with extremely green refrigerant.

Superior control logic. The EWWH~VZ A series is enjoying MicroTech III controller that provides an easy to use control environment. The control logic is designed to provide highest efficiency performances and continuous operation. Easy interface with LonWorks, Bacnet, TCP/IP or Modbus communication protocols.

Quiet operation. Very low sound levels are achieved at part loads thanks to the reduction of compressor rotational speed. Compressor sound proof cabinet option is available to further reduce sound level.

No starting current. No any current spike is experienced at start up thanks to inverter driven compressor motors. The starting current is always lower than full load current (FLA).

Displacement power factor always > 0,95. Thanks to inverter driven compressors, the EWWH~VZ A series always operates with a displacement power factor > 0,95 allowing to avoid power factor penalties and decreasing electrical losses in cables and transformers.

Codes and Certifications. The EWWH~VZ A series is CE marked, complying with European directive in force concerning manufacturing and safety. Units are designed and manufactured in accordance with applicable selections of the following:

- Construction of pressure vessel 2014/68/EU Machinery Directive 2006/42/EC
- Low Voltage 2014/35/EU
- Electromagnetic Compatibility 2014/30/EU
- Electrical & Safety codes EN60204-1/EN61439 1/EN61439-2
- Manufacturing & Quality Standards UNI EN ISO 9001:2008
- Environmental Management System UNI EN ISO 14001:2004
- Health & Safety Management System BS OHSAS 18001:2007

Additional information related to F-GAS Regulation (EU) No 517/2014 of the European Parliament and of the Council of 16th April 2014 on fluorinated greenhouse gases and repealing Regulation (EC) No 842/2006.

Unit model	Refrigerant type	Refrigerant GWP	No. of circuits	Refrigerant charge circuit 1 (kg)	Refrigerant charge circuit 1 (TCO2Eq)	Refrigerant charge circuit 2 (kg)	Refrigerant charge circuit 2 (TCO2Eq)
EWWH445VZSSA1	R1234ze	7	1	100	0,7	-	-
EWWH515VZSSA1	R1234ze	7	1	110	0,8	-	-
EWWH550VZSSA1	R1234ze	7	1	110	0,8	-	-
EWWH660VZSSA1	R1234ze	7	1	170	1,2	-	-
EWWH770VZSSA1	R1234ze	7	1	180	1,3	-	-
EWWH860VZSSA2	R1234ze	7	2	125	0,9	125	0,9
EWWH940VZSSA2	R1234ze	7	2	130	0,9	130	0,9
EWWHC10VZSSA2	R1234ze	7	2	145	1,0	145	1,0
EWWHC12VZSSA2	R1234ze	7	2	145	1,0	145	1,0
EWWHC13VZSSA2	R1234ze	7	2	160	1,1	160	1,1
EWWHC14VZSSA2	R1234ze	7	2	160	1,1	160	1,1
EWWHC15VZSSA2	R1234ze	7	2	175	1,2	175	1,2
EWWH335VZXSA1	R1234ze	7	1	95	0,7	-	-
EWWH365VZXSA1	R1234ze	7	1	95	0,7	-	-
EWWH450VZXSA1	R1234ze	7	1	100	0,7	-	-
EWWH525VZXSA1	R1234ze	7	1	110	0,8	-	-
EWWH580VZXSA1	R1234ze	7	1	170	1,2	-	-
EWWH670VZXSA1	R1234ze	7	1	170	1,2	-	-
EWWH800VZXSA1	R1234ze	7	1	180	1,3	-	-
EWWH875VZXSA2	R1234ze	7	2	125	0,9	125	0,9
EWWH950VZXSA2	R1234ze	7	2	130	0,9	130	0,9
EWWHC11VZXSA2	R1234ze	7	2	145	1,0	145	1,0
EWWHC12VZXSA2	R1234ze	7	2	145	1,0	145	1,0
EWWHC13VZXSA2	R1234ze	7	2	160	1,1	160	1,1
EWWHC14VZXSA2	R1234ze	7	2	160	1,1	160	1,1
EWWHC15VZXSA2	R1234ze	7	2	175	1,2	175	1,2
EWWH370VZPSA1	R1234ze	7	2	100	0,7	-	-
EWWH530VZPSA1	R1234ze	7	2	150	1,1	-	-
EWWH680VZPSA1	R1234ze	7	2	180	1,3	-	-
EWWH880VZPSA2	R1234ze	7	2	145	1,0	145	1,0
EWWHC12VZPSA2	R1234ze	7	2	160	1,1	160	1,1
EWWHC13VZPSA2	R1234ze	7	2	175	1,2	175	1,2

Note: Equipment contains fluorinated greenhouse gases. Actual refrigerant charge depends on the final unit construction, details can be found on the unit nameplate.

General Characteristics

Product line up is made by single compressor models from 350 kW up to 800 kW. From 900 kW up to 1500 kW, models are with two compressors on two independent refrigerant circuits. In this case, all main components are duplicated per each circuit in order to have the highest redundancy*.

Single compressor unit

350 kW – 800 kW



Dual compressor unit

900 kW – 1500 kW



*Dual compressor unit are supplied with a single temperature probe for condensers outlet. The installing of the probe on the common line is an installer responsibility.

Cabinet and structure. The cabinet is made of galvanized steel and painted to provide high resistance to corrosion. Color is Ivory White (Munsell code 5Y7.5/1, ± RAL7044). Unit is fitted with eyehook for lifting with ropes and for an easy handling. The weight is uniformly distributed along the base's profiles for a simplified unit installation.

Inverter Driven Single Screw Compressor. The EWWH~VZ A series is equipped with latest Daikin design Single Screw Compressors. This technology is enjoying highly balanced loads resulting in reduced mechanical stress for the main components. Lifetime and reliability are in this way improved and, at the same time, vibrations and noise emissions are reduced. The high volumetric efficiency of Daikin single screw compressors makes them the ideal solution for variable speed applications. Thanks to inverter technology the EWWH~VZ A screw compressors are able to match the cooling output of the unit to the actual load requirement. Compressor's rotational speed is continuously adjusted (stepless regulation) allowing excellent water temperature control and efficient capacity modulation.

Compressors are enjoying the Variable Volume Ratio (VVR) technology. This innovative system allows the compressor to adapt the discharge pressure of the refrigerant to the specific operating conditions. In this way, it is possible to prevent energy losses deriving from under or over compression phenomena that are typical of traditional compressor technologies (with fixed volume ratio). The reduction of energy losses inside compressor brings to an increased unit efficiency. Oil separator is integrated within the Condenser shell.

Low GWP refrigerant Latest revision of F-GAS, entered into force in 2015, set up a phase down program for traditional HFC's refrigerants. In 2018 first significant reduction step will be introduced (37%) and in 2030 the reduction (calculated in equivalent CO2 tons) will need to achieve almost 80%.

HFC's phase down objectives*:

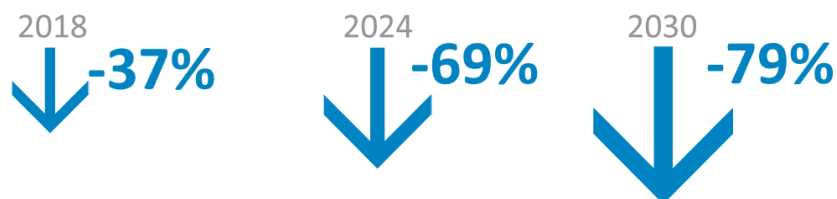

(*) Baseline value (100%) is the annual average of total quantity of CO2 equivalents placed on EU Market from 2009 to 2012

The most popular hydro-fluorocarbon (HFC) refrigerants for screw chiller applications is R-134a, that is the first non-ozone-depleting fluorocarbon refrigerant to be commercialized. It is a single-component refrigerant, so with no glide. Refrigerant R-1234ze is the best alternative with low GWP for screw chiller applications. It belongs to the family of HFO fluids (Hydrofluoroolefins): like traditional hydrofluorocarbons (HFCs), they are composed from hydrogen, fluorine and

carbon. The only difference is that they are unsaturated and contain a carbon-carbon double bond, featured by zero ODP (Ozone Depletion Potential) and very low GWP (Global Warming Potential<11), resulting in low TEWI (Total Equivalent Warming Impact).

Comparison on thermophysical properties between R-134a and R-1234ze

Refrigerant name	R-134a	R-1234ze
ODP	0	0
GWP	1300 ¹ /1430 ²	<1 ¹ /6 ²
Toxicity	Class A ³ (non toxic)	Class A ³ (non toxic)
Safety group (ANSI/ASHRAE 34-2007)	A1 ³	A2L ³
Normal boiling temperature	-26,4	-19,3
Critical temperature	101,1	109,4

¹IPCC fifth assessment report 2014 (AR5).²IPCC fourth assessment report (AR4 - reference for F-GAS Regulation (EU) No 517/2014). ³ Source: ISO 817:2014 : Designation and Safety Classification of Refrigerants.

R-1234ze is categorized under the A2L flammability class of ASHRAE. For installation requirements, please refer to IOM manual.

Evaporator. High efficiency flooded type shell and tube heat exchanger. Evaporator tubes have been selected in order to achieve the highest heat transfer. Optimized nucleate boiling is guaranteed by specifically designed cavities on the external tubes’ surface. Internal tubes surface area has helical type design. The extremely high heat transfer coefficient allows the reduction of the temperature difference between chilled water and refrigerant thus resulting in higher overall unit efficiency. The evaporator is designed according to 2014/68/EU European standard (Construction of pressure vessel). The water side is designed for 10 bar maximum operating pressure; vents and drain are provided. Water connections are Victaulic type as standard, flanged connections are available as optional. As standard unit evaporator is two water passes design. As standard, thermal insulation (20 mm thickness) is fitted on the external evaporator surface area.

Condenser. High efficiency shell and tube type heat exchanger. Condenser tubes have been selected in order to achieve the highest heat transfer. Optimized condensation is achieved by finned type tube external surface area. Internal tubes surface area has helical type design. The extremely high heat transfer coefficient allows the reduction of the temperature difference between condenser water and refrigerant thus resulting in higher overall unit efficiency. The condenser is designed according to 2014/68/EU European standard (Construction of pressure vessel). The water side is designed for 10 bar maximum operating pressure; vents and drain are provided. Water connections are Victaulic type as standard, flanged connections are available as optional. Unit condenser is single water pass with counter-flow design for optimize heat transfer between water and refrigerant. Within Condenser shell, specific section is dedicated to the oil separation, that allows very low oil carry over and extremely reduced refrigerant pressure drops.

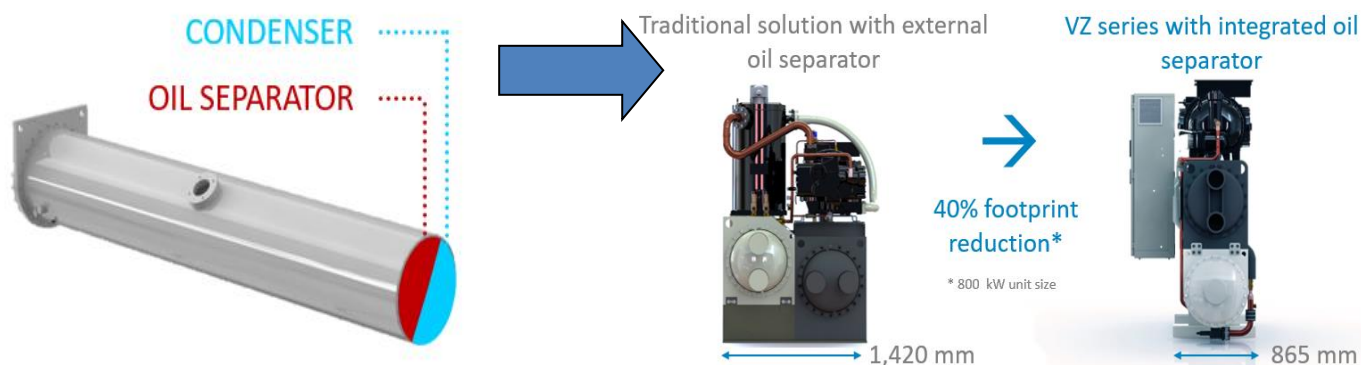

Thanks to the new condenser technology VZ series is enjoying 40% reduced footprint if compared with previous generation of water cooled chillers. The width of the units up to 800 kW can be reduced below 900 mm (selecting opt.167, knock down electrical panel) allowing installation throughout the tightest doorways. This is great advantage especially for replacement projects.

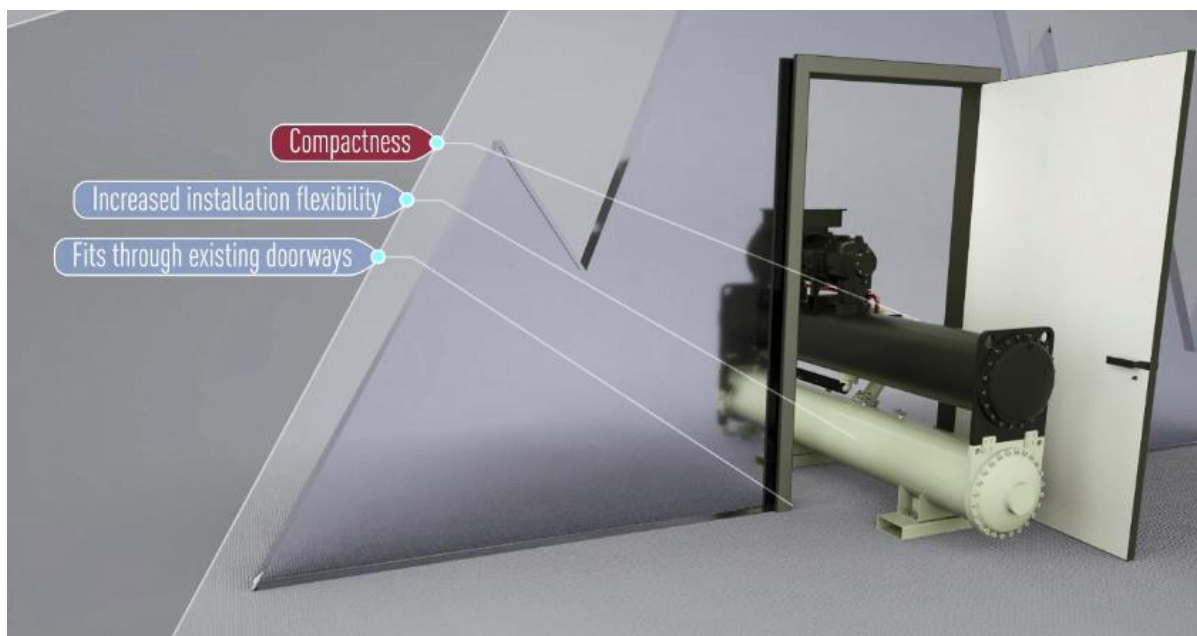

Electronic expansion valve. Unit is equipped with latest technology electronic expansion valve to achieve precise control of refrigerant mass flow. As today's system requires improved energy efficiency, tighter temperature control and wide operating range, the application of electronic expansion valve is the recommended solution. Electronic expansion valve provides unique features such as short opening and closing times, high resolution, positive shut-off function eliminating the need for additional solenoid valve, continuous modulation of mass flow with reduced stress in the refrigerant circuit.

Refrigerant Circuit. Each unit has one or two independent refrigerant circuits and each of them includes:

- Single screw compressor inverter driven
- Refrigerant charge
- Independent refrigerant circuit into the evaporator
- Water cooled condenser
- Electronic expansion valve
- Liquid line shut off valve
- Sight glass with moisture indicator
- High pressure switch
- High pressure transducer
- Low pressure transducer
- Oil pressure transducer
- Suction temperature sensor

Electrical Panel. Power and control sections are located into the main electrical panel IP54 designed. The main panel doors are interlocked to the main switch (standard) in order guarantee safe operation when doors are opened. The power section includes compressor protection devices and compressor starters (inverter type).

MicroTech III Controller. The MicroTech III control system consists of a microprocessor-based controller and a number of extension modules, which vary depending on the unit size and configuration. The system provides the monitoring and control functions required for an efficient and trouble free operation of the chiller.

A display installed on the outside of the control panel's door allows easy access to chiller operating status including water temperatures and refrigerant pressures and temperatures.

A sophisticated software with predictive logic selects the most energy efficient combination of compressor load and electronic expansion valve position keeping stable operating conditions and maximizing chiller efficiency and reliability.

In addition to normal operating functionalities, MicroTech III controller will take corrective actions in case the chiller operating outside recommended working conditions.

Unit controller is able to protect critical unit components thanks to the signals received by the various unit sensors (such as motor temperature sensors, refrigerant and oil pressure/temperature sensors, pressure switches.....etc..).

Main control features are (for more information refer to Unit Control Manual):

- Optimized management of compressors stepless capacity control through inverter drive.
- Display of evaporator entering/leaving water temperatures.

- Display of condenser entering/leaving water temperatures.
- Display of refrigerant condensing/evaporating temperatures and pressures.
- Regulation of leaving evaporator water (cooling mode) or condenser water (heating mode).
- Display of compressor working hours and number of compressor starts.
- Re-start in case of power failure (automatic or manual depending on failure type).
- Soft load (optimized management of the compressor load during the start-up).
- Set point reset.
- Master/Slave operation (up to 4 chillers connected).

Alarms signaling (for more information refer to Unit Control Manual):

- Phase loss.
- Evaporator water flow loss.
- Evaporator water freezing protection.
- External alarm.
- Low evaporator refrigerant pressure.
- High refrigerant pressure (transducer).
- High refrigerant pressure (switch).
- Low pressure ratio.
- High refrigerant discharge temperature.
- High oil pressure differential.
- High motor temperature.

Alarm logging: when alarm occurs, the alarm type, date, time and main unit working parameters are recorder and stored into the controller memory. The last 25 alarms occurred are stored.

Regulation type: Proportional-Integral-Derivative (PID) type based on the evaporator leaving water temperature set point (cooling mode) or based on the condenser leaving water temperature set point (heating mode).

Connection to BMS: MicroTech III controlled is capable to communicate with BMS systems based on the most common protocols such as: Modbus, LonWorks, BacNet IP and MS/TP (class 4), Ethernet TCP/IP. Communication cards (optional) are to be selected according to the required communication protocol.

Nomenclature

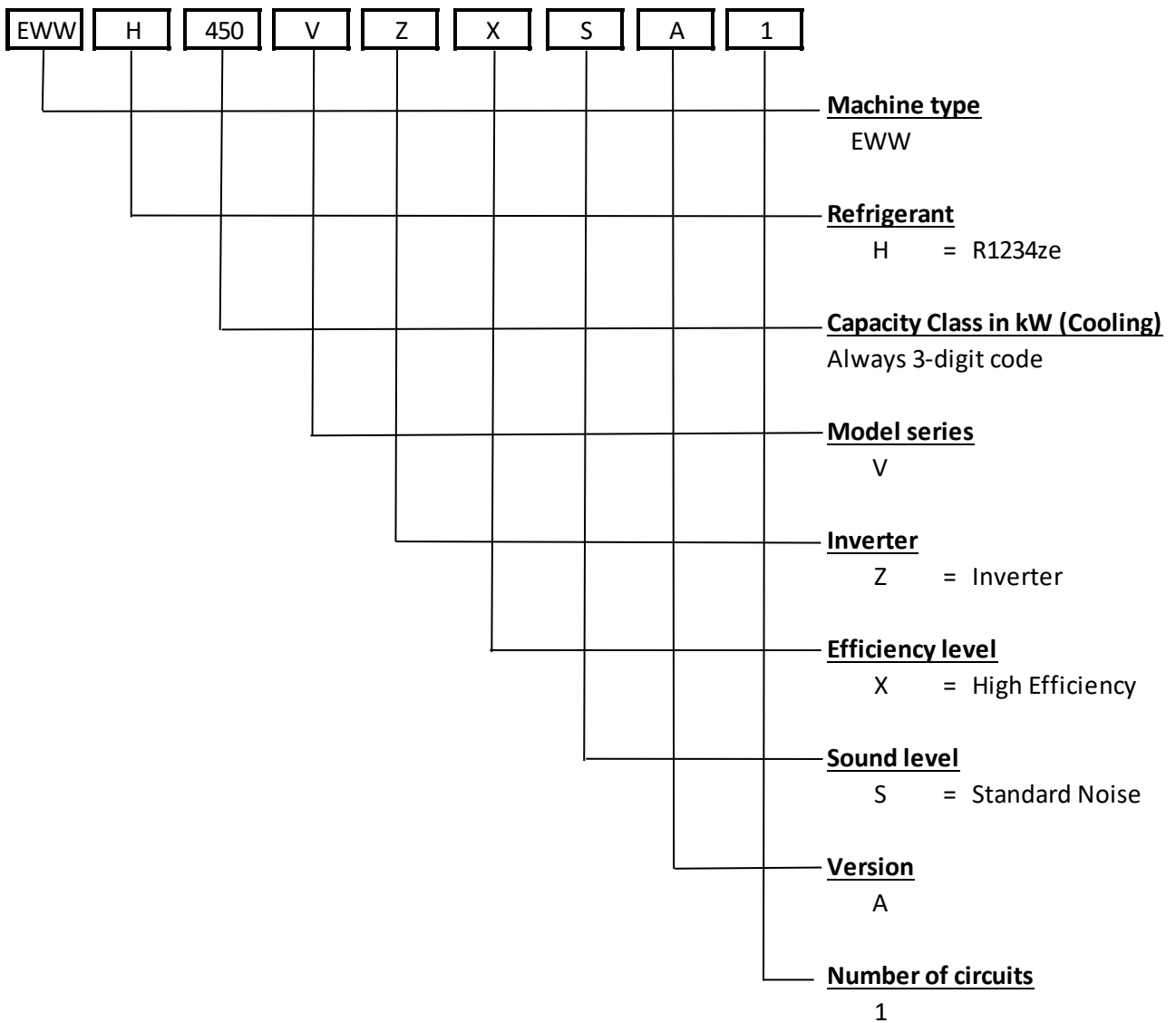

Standard Options (Supplied on basic unit)

Double set point (option 10 – STANDARD). Possibility to pre-set two different chilled water temperature set points (cooling mode) or two different hot water temperature set points (heating mode).

Compressor thermal overload relays (option 11 – STANDARD). Functionality Included in the compressor inverter device - *Option incompatibility: 95*

Phase monitor (option 13 – STANDARD). Functionality Included in the compressor inverter device. Protect the unit in case of phase loss or phase reversal.

Inverter compressor starter (option 14 – STANDARD). Electronic device used as starter and for compressor capacity control.

Under/over voltage control (option 15 – STANDARD). Functionality Included in the compressor inverter device. Electronic device that monitors and displays input voltage, and stops the chiller in case of phase loss, wrong phase sequence, or voltage exceeding minimum and maximum allowed values.

Evaporator Victaulic kit (option 20 - STANDARD). Victaulic joints and counter-pipes - *Option incompatibility: 104.*

Evaporator water design pressure 10 bar (option 27 – STANDARD).

20 mm evaporator insulation (option 29 – STANDARD). Thermal insulation of the evaporator shell - *Option incompatibility: 08-174.*

Condenser Victaulic kit (option 36 - STANDARD). Victaulic joints and counter-pipes - *Option incompatibility: 26-50.*

Condenser water design pressure 10 bar (option 47a – STANDARD).

Condenser single pass (option 51 – STANDARD). Single pass water side design. Refer to unit dimensional drawing for water INLET/OUTLET details. Water connections cannot be reversed.

Electronic expansion valve (option 60 – STANDARD).

Hour run meter (option 68 – STANDARD). Standard functionality of unit controller.

General fault contactor (option 69 – STANDARD). Standard functionality of unit controller.

Set point reset, demand limit and alarm from an external device (option 90 – STANDARD). Standard functionality of unit controller. Set point reset: possibility to re-set the water temperature set point by means of a 4-20 mA signal. Demand Limit: possibility to limit unit capacity by means of 4-20 mA signal. Alarm from external device: unit controller capability to receive an external alarm signal. The user can decide whether this alarm signal will stop the unit controller or not. Refer to unit control manual for more information.

Double pressure relief valve with diverter (opt.91 – STANDARD).

Main switch interlocked doors (option 97 – STANDARD). Electrical panel's doors are interlocked with the main switch isolator for safe operation.

Evaporator two passes (option 103a – STANDARD). Two passes water side design. Refer to unit dimensional drawing for water INLET/OUTLET details - *Option incompatibility: 103-103b.*

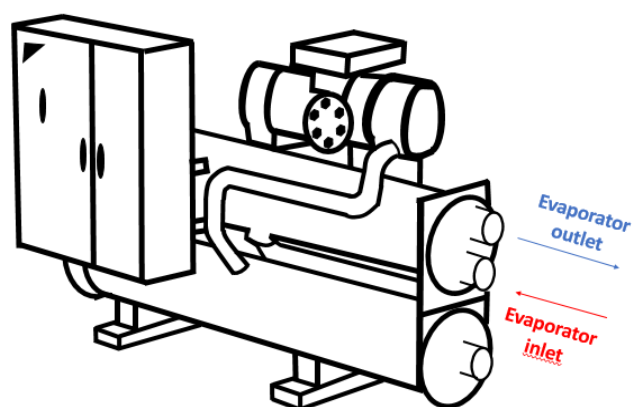

Master/Slave (option 128 – STANDARD). Standard controller functionality allowing to connect up to 4 units (of the same series) and providing basic sequencing functionalities such as: balancing of working hours of unit & compressors. An additional probe (PT1000 or NTC10K, not provided by Factory) must be installed on the common water header and connected to the master unit.

Options on request

MECHANICAL OPTIONS

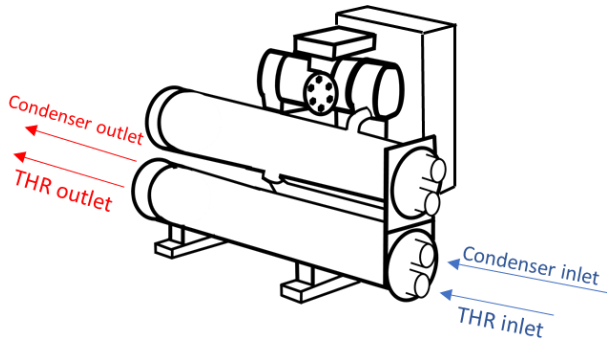

Total heat recovery (option 01 – ON REQUEST). Unit is equipped with a double tube bundle in the condenser (one for cooling water, one for heat recovery water). Heat exchanger heads are provided with 2 connections for entering/leaving heat recovery water and 2 separate connections for condensing water. An additional temperature probe (not provided by the factory) must be installed at the inlet of total heat recovery exchanger (customer side). Total heat recovery option is available only for GOLD version - *Option incompatibility: 07a-33-111-149-150.*

Total heat recovery operation has to be managed on site. When heat recovery is needed, customer controller needs to turn on total heat recovery pumps and to switch off the condensing pumps.

Note the heat recovery is available only when cooling load is requested and capacity available is result of the cooling demand.

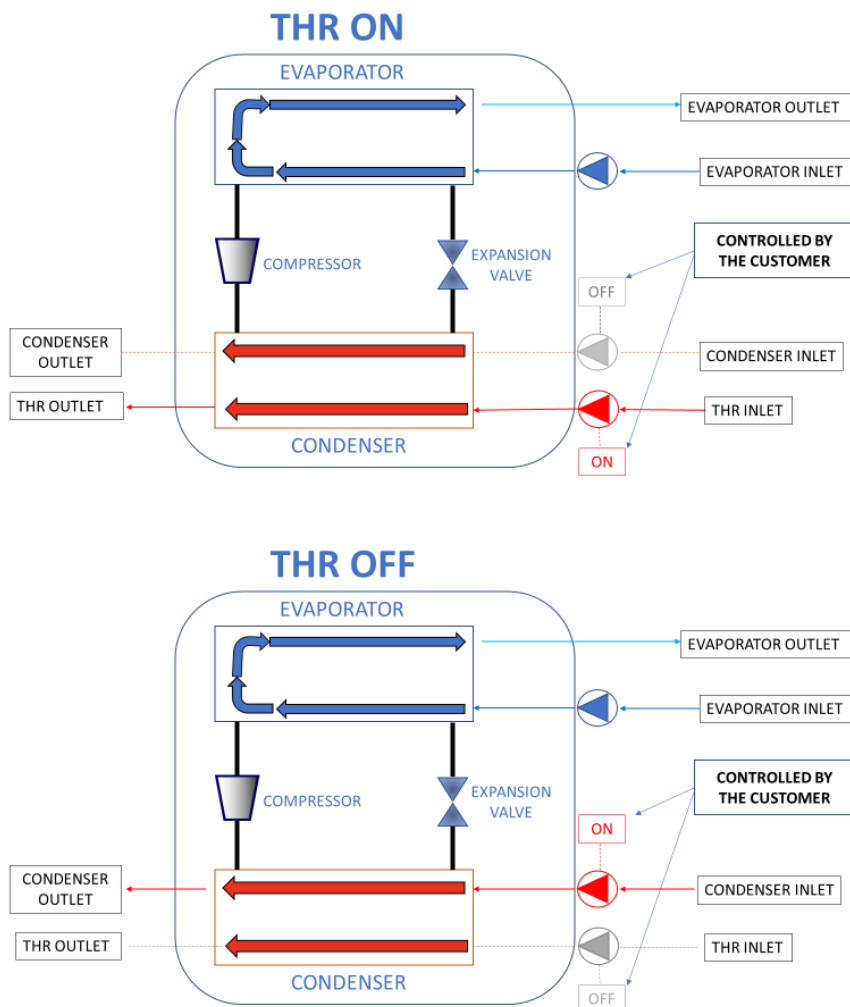

Heat Pump Version – including Pursuit Mode (option 07a – ON REQUEST). Reversibility on the water side. Unit capability to follow two different set points (cooling mode or heating mode). During “cooling mode operation”, unit microprocessor is following evaporator leaving water temperature set point. When the machine is switched to “heating mode operation”, the unit microprocessor is following condenser leaving water temperature set point. Cooling or heating mode operation can be selected by means of a dedicated switch installed on the unit electrical panel. If communication card is selected, cooling or heating mode operation can be managed by BMS. Heat Pump Version option includes 20 mm condenser insulation (option 33).

In case pursuit mode operation is enabled via Microtech III, unit controller will follow both set points (cooling and heating). When the first set point is satisfied, either the cold or the hot one, the unit will maintain that set point. Ideal applications are when cooling and heating loads are balanced. Pursuit mode operation is not recommended in case of unbalanced loads (e.g. 80% of nominal cooling load and 20% of nominal heating load) - *Option incompatibility: 33-111.*

Brine Version (option 08 – ON REQUEST). Required in case of unit operation with chilled water temperatures below +4°C. Unit will be fitted with double thermal insulation on evaporator (40 mm thickness). Brine Version option includes compressor thermal insulation option (option 146). Refer to the unit operating envelope for more information about minimum allowed evaporator leaving water temperatures. - *Option incompatibility: 146-174-29.*

Low Brine Version (option 174 – ON REQUEST). Required in case of unit operation with chilled water below -6°C with Ethylene glycol and 0°C with Propylene glycol. Option includes a dedicated tubes selection to allow operation at low temperature. Unit will be fitted with double thermal insulation on evaporator (40 mm thickness) and compressor thermal insulation (opt.146). Refer to the unit operating envelope for more information about minimum allowed evaporator leaving water temperatures. To select unit with opt.174 refer to CSS web. Unit selected with opt.174 needs to be ordered with such option. Is not possible on site to retrofit units with op.174 - *Option incompatibility: 146-08-29.*

Condenser double flanges kit (option 26 – ON REQUEST). Victaulic-to-flange adapter (shipped loose and including counter-flanges, gaskets and bolts) - *Option incompatibility: 36.*

20 mm condenser insulation (option 33 – ON REQUEST). Thermal insulation of the condenser shell (included with option 07a – Heat Pump Version and with option 111 – High temperature kit). *Option incompatibility: 07a-111.*

Cu-Ni 90-10 condenser tubes (option 50 – ON REQUEST). Condenser tubes made of Cu-Ni 90-10 material and Cu-Ni 90-10 tube sheets cladding. Epoxy ceramic coating of water headers and sacrificial anodes. Cupronickel is highly resistance to corrosion in seawater; for this reason it is used for piping in seawater system. Unit performances may differ from standard. Contact factory for more details. When selecting option 50, condenser double flanges kit option (option 26) must be selected as well - *Option incompatibility: 36.*

Discharge line shut off valve (option 61 – ON REQUEST). Installed on the discharge line of the compressor to facilitate maintenance operations.

Suction line shut off valve (option 62 – ON REQUEST). Installed on the suction line of the compressor to facilitate maintenance operations.

High-pressure side manometers (option 63 – ON REQUEST).

Low-pressure side manometers (option 64 – ON REQUEST).

Soundproof system - Integral (option 76-a – ON REQUEST). High performance soundproof cabinet made in pre-coated galvanized steel installed around the entire unit. The profile (in natural aluminum) is designed for indoor installations and allow the unit to work without a bottom panel/base frame. Panels in mineral wool are installed in order to minimize unit sound level (~12 dB(A)). Electrical panel is installed outside the Sound proof cabinet to ensure the proper ventilation. Sound proof cabinet will be supplied dismantled (shipped loose) with mounting instructions. Mounting of the cabinet and the cuttings of the cabinet in proximity of the rear part of electrical panel and in correspondence of the water connections of the heat exchangers has to be done on site (customer responsibility).

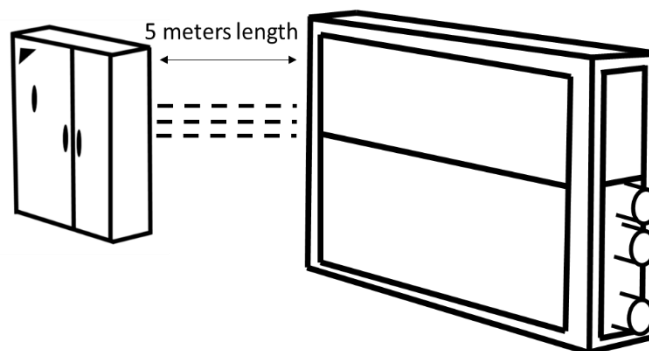

Factory provided the electrical panel dismantled and shipped loose. Electrical panel has to be installed on-site considering the following specifications:

- Remote panel must be visible from the unit;
- Remote panel has to be positioned lifted from the ground, in order to guarantee adequate ventilation;
- Remote panel assembly activity has to be done on site and is a responsibility of the customer.

Compressor soundproof system (option 76-b – ON REQUEST). High performance soundproof cabinet installed around compressor and specifically designed in order to decrease unit sound levels (~3dB(A)).

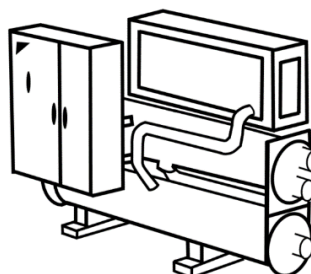

Victaulic-to-flange

Evaporator double flanges kit (option 104 – ON REQUEST). adapter (shipped loose and including counter-flanges, gaskets and bolts).

Refrigerant leak detection (option 121 – ON REQUEST). Electronic device (shipped loose) for automatic detection of refrigerant leak. The leak detection device should be installed within the machinery room in the most appropriate location (refer to the leak detection device installation manual). When leak above a pre-set concentration of refrigerant (2000 ppm) is detected, signal is sent to unit controller (a specific alarm is visualized on the unit microprocessor’s display). The Factory does not supply interconnecting cables between leak detection device and unit controller.

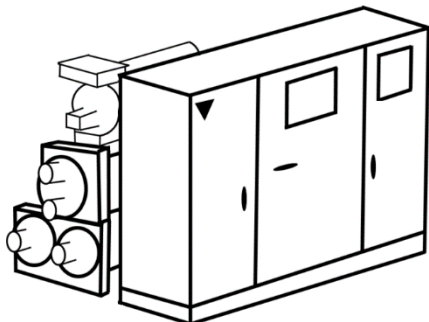

High temperature kit (option 111 – ON REQUEST). Required in case of condenser leaving water temperature higher than approximately 48°C (note: this limit may change depending on evaporator water temperature and on specific unit version/size. Refer to operating envelope and to chiller selection software for detailed information). Specifically selected components are used in order to allow the unit to operate at such conditions. Unit dimensions and weight may change from standard. For the biggest size electrical panel is available in free-standing installation (on ground), refer to the unit dimensional confirmed drawing. High temperature kit option includes 20 mm condenser insulation (option 33) and heat pump version (option 07a). Unit selected with opt.111 needs to be ordered with such option. Is not possible on site to retrofit units with op.111 - *Option incompatibility: 07a-33-149-150.*

Compressor thermal insulation (option 146 – ON REQUEST). 20 mm thermal insulation of compressor suction side. (Included with option 08 – Brine version) - *Option incompatibility: 08-174.*

Knock down electrical panel (option 147 – ON REQUEST). Electrical panel dismantled from the unit and shipped separately, in order to reduce dimensions of the unit during the delivery and the installation. The mounting of the electrical panel is in charge of the customer. In case of remote control panel required (max. 5 mt additional cable length), please contact the factory. The unit must be visible from electrical panel position. Remote electrical panel must be installed lifted from ground, in order to ensure the proper ventilation.

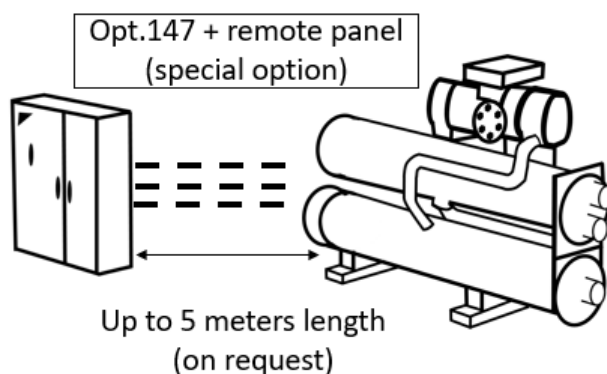
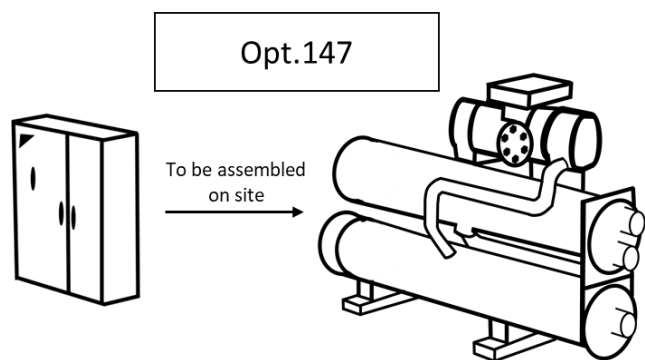

Evaporator single pass (option 103 – ON REQUEST). Single pass water side evaporator. May be required in case of evaporator water temperature difference lower than 4°C. Unit performances may differ from standard. Refer to CSS web for more details- *Option incompatibility: 103a-103b.*

Evaporator 3 passes (option 103b – ON REQUEST). Three passes water side evaporator. May be required in case of evaporator water temperature difference higher than 8°C. Unit performances may differ from standard. Refer to CSS web for more details - *Option incompatibility: 103-103a.*

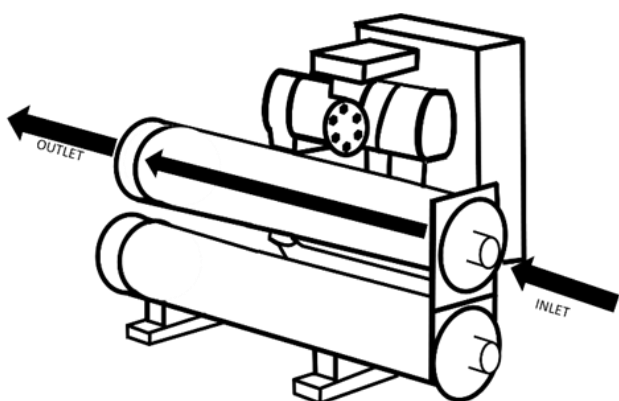

SINGLE PASS EVAPORATOR

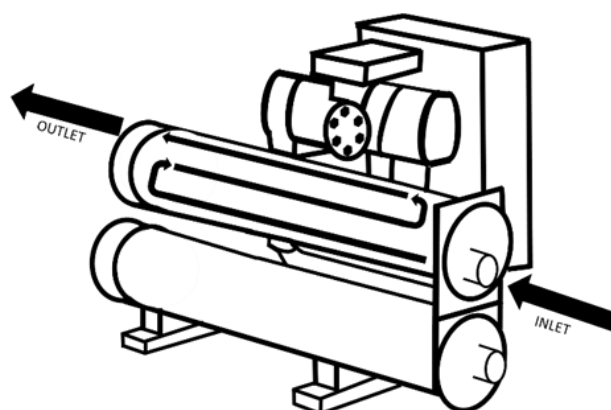

THREE PASSES EVAPORATOR

ELECTRICAL OPTIONS

Energy meter – including current limit (option 16a – ON REQUEST). Electronic device installed within unit electrical panel. Measures and display supply line individual phase voltage and current, active and reactive power input, active and reactive energy consumption. An integrated RS485 module allows Modbus communication to BMS. It includes current limit functionality.

Evaporator flow switch (option 58 – ON REQUEST). Paddle flow switch shipped loose. Refer to unit installation manual for more details.

Condenser flow switch (option 59 – ON REQUEST). Paddle flow switch shipped loose. Refer to unit installation manual for more details.

Compressor circuit breakers (option 95 – ON REQUEST). Protection device including protection from current overload and overcurrent. In case this option is selected, compressor fuses are removed - *Option incompatibility: 11.*

Ground fault relay (option 102 – ON REQUEST). Unit shuts down in case of ground fault is detected.

Rapid restart (option 110 – ON REQUEST). Ideal solution for those critical applications that cannot afford the loose of cooling or heating. In case of power failure unit will re-start as fast as 15 seconds from power restoration. Unit will reach full load within 160 seconds and 180 seconds respectively for single compressor and dual compressors unit models. Refer to unit control manual for more information about this option.

Automatic transfer switch – free standing (option 149 – ON REQUEST). Free standing panel separate from the unit allowing to connect two separate power supply lines (e.g. main supply line and secondary line from backup generator). In case of failure of main power supply line, the automatic transfer switch device will automatically switch to the secondary line if power is detected - *Option incompatibility: 111.*

Inverter EN61800-3 Class C2 compliant (option 150 – ON REQUEST). Additional RFI filters on the unit power supply line. Reduces electromagnetic interferences. Increases the inverter immunity level according to residential environment and allows its compliancy with emissions level required in C2 category - *Option incompatibility: 111.*

Daikin on site modem with antenna (opt. code 155). Whenever LAN connection to the unit will not be available, connecting the unit to Daikin on Site will be possible through a dedicated 3G M2M modem that can be ordered from Factory. When ordered, the modem will be installed on the unit before leaving the Factory.

INSTALLATION OPTIONS

Rubber pads (option 152 – ON REQUEST). Rubber pad mounts to be installed under the unit base frame during installation.

OTHER OPTIONS

Container kit (option 71 – ON REQUEST). Dedicated yellow base supplied for the shipment of the unit, specially designed to ease loading/unloading operation into the container (standard option for mono-circuit unit) - *Option incompatibility: 112.*

Transport kit (option 112 – ON REQUEST). Wooden pallet covered by a Ethafoam lay that is located between the unit and the pallet, in order to offer additional shock absorption during transportation. - *Option incompatibility: 71.*

Marine Version (option 167 – on request).

In marine applications, chillers may be exposed to specific operating conditions (depending on the installation), such as:

- Pitch and roll conditions can affect the refrigerant and oil circuits operation;
- Vibrations, with impact on the mechanical parts of the unit;
- Sea water (on condenser side).

Marine Version is composed by a set of solutions in order to meet every specific need (as standard, included in opt. 167):

- *Special cross-flow condenser specifically designed to operate in pitch and roll conditions;*
- *Oil sump to ensure proper oil return, in pitch and roll operation;*
- *Accelerometer activating dedicated EEXV control specifically designed for marine applications;*
- *Dedicated Circuit breaker in order to improve electrical protection of the auxiliary circuits;*
- *Running lamps and digital outputs signal;*
- *Cable trays in stainless steel, specific for corrosive environment.*

To select unit with opt. 167, please refer to the factory.

In addition to the above further customization are possible, such as:

- Cu-Ni condenser (Option 50 in price list) – to prevent damages on condenser due to sea water application. Performance of the unit will be different than VZ standard. To select unit with opt. 50 refer to CSS web;
- Halogen free cables and insulation;
- Power Supply 690V/60Hz;
- Power Supply 440V/60Hz;
- IT-system for the Inverter;
- Nitrogen charge in heat exchangers before shipment, to preserve reliability for long term storage period of the unit;
- Marine certification for heat exchangers (i.e. DNVGL, Lloyd's, RINA, Bureau Veritas, ecc...);
- Marine water box (evaporator-opt.25; condenser-opt.41). This option consists of a cylindrical box installed at one of the two vessel heads (customer can decide which one of the heads, basing on the installation site layout). It is available with Victaulic or flanged connection.

Contact factory for feasibility analysis and quotations.

EWWH~VZ-SS

MODEL		EWWH445V ZSSA1	EWWH515V ZSSA1	EWWH550V ZSSA1	EWWH660V ZSSA1	EWWH770V ZSSA1	EWWH860V ZSSA2
COOLING PERFORMANCE							
Capacity - Cooling	kW	443	512	548	657	768	865
Capacity control - Type		Stepless	Stepless	Stepless	Stepless	Stepless	Stepless
Capacity control - Minimum capacity	%	20	20	20	20	20	10
Unit power input - Cooling	kW	82.8	98.1	106	123	149	172
EER		5.35	5.22	5.15	5.34	5.14	5.02
ESEER		7.98	7.83	7.90	8.03	7.99	7.93
IPLV		9.25	9.25	9.24	9.48	9.32	8.94
SEASONAL ENERGY EFFICIENCY ****							
SEER (12/7°C)		8.61	8.66	8.62	8.91	8.83	8.16
$\eta_{s,cool}(12/7°C)$	%	336.4	338.4	336.8	348.4	345.2	318.4
DIMENSIONS							
Height	mm	2123	2123	2123	2292	2487	2296
Width	mm	1178	1179	1179	1233	1303	1484
Length	mm	3722	3750	3750	3690	3822	4792
WEIGHT							
Unit Weight	kg	2892	2928	2941	3451	4237	5570
Operating Weight	kg	2977	3033	3053	3611	4488	5980
HEAT EXCHANGER - EVAPORATOR							
Type *		Flooded S&T	Flooded S&T	Flooded S&T	Flooded S&T	Flooded S&T	Flooded S&T
Fluid		Water	Water	Water	Water	Water	Water
Fouling Factor	m ² °C /W	0	0	0	0	0	0
Water Volume	l	88	88	96	134	156	230
Water temperature in	°C	12	12	12	12	12	12
Water temperature out	°C	7	7	7	7	7	7
Water flow rate	l/s	21.2	24.5	26.2	31.5	36.8	41.4
Water pressure drop	kPa	46.0	61.0	52.0	59.0	64.0	39.0
HEAT EXCHANGER - CONDENSER							
Type *		S&T	S&T	S&T	S&T	S&T	S&T
Fluid		Water	Water	Water	Water	Water	Water
Fouling Factor	m ² °C /W	0	0	0	0	0	0
Water Volume	l	81	102	102	126	217	180
Water temperature in	°C	30	30	30	30	30	30
Water temperature out	°C	35	35	35	35	35	35
Water flow rate	l/s	25.5	29.6	31.8	38.1	44.8	50.3
Water pressure drop	kPa	19.0	17.0	20.0	19.0	17.0	25.0
COMPRESSOR							
Oil charge	l	36.0	36.0	36.0	50.0	50.0	68.0
Quantity	No.	1	1	1	1	1	2
SOUND LEVEL**							
Sound Power - Cooling	dB(A)	101	105	105	105	107	106
Sound Pressure level@1m distance - Cooling	dB(A)	82	86	86	86	88	87
REFRIGERANT CIRCUIT							
Refrigerant type		R1234ze	R1234ze	R1234ze	R1234ze	R1234ze	R1234ze
Refrigerant charge	kg	100	110	110	170	180	250
N. of circuits	No.	1	1	1	1	1	2
PIPING CONNECTIONS							
Evaporator water inlet/outlet	mm	139.7	139.7	139.7	168.3	219.1	219.1
Condenser water inlet/outlet	mm	168.3	168.3	168.3	219.1	219.1	168.3/168.3

All the performances (Cooling capacity, unit power input and EER) are based on the following conditions: evaporator 12.0/7.0°C; condenser 30.0/35.0°C, unit at full load operation; operating fluid: Water; fouling factor = 0. S&T: Single Pass Shell & Tube; CC: Closed Cell; (**) The values are according to ISO 3744 and are referred to: evaporator 12/7° C, condenser 30/35° C, full load operation. The minimum capacity indicated is referred to unit operating at standard Eurovent conditions. Dimensions and weights are for indication only and not considered binding. Before designing the installation, consult the official drawings available from the factory at request. All the data are referred to standard unit without options. All data are subject to change without notice. (***) The value refers to the pressure drops in the evaporator/condenser only). (****) In accordance with standard EN14825:2013, comfort low temperature, average climate. SEER and η_s values applicable Ecodesign regulation: (EU) No 2016/2281.

Eurovent certified values

EWWH~VZ-SS

MODEL		EWWH940V ZSSA2	EWWHC10V ZSSA2	EWWHC12V ZSSA2	EWWHC13V ZSSA2	EWWHC14V ZSSA2	EWWHC15V ZSSA2
COOLING PERFORMANCE							
Capacity - Cooling	kW	941	1,012	1,142	1,271	1,396	1,525
Capacity control - Type		Stepless	Stepless	Stepless	Stepless	Stepless	Stepless
Capacity control - Minimum capacity	%	10	10	10	10	10	10
Unit power input - Cooling	kW	188	205	234	253	282	302
EER		5.00	4.93	4.87	5.01	4.95	5.04
ESEER		7.95	8.12	8.00	8.46	8.00	8.48
IPLV		9.08	9.13	9.14	9.30	9.13	9.34
SEASONAL ENERGY EFFICIENCY ****							
SEER (12/7°C)		8.38	8.69	8.48	8.7	8.84	9.03
$\eta_{s,cool}(12/7°C)$	%	327.2	339.6	331.2	340	345.6	353.2
DIMENSIONS							
Height	mm	2296	2296	2296	2350	2338	2498
Width	mm	1487	1487	1484	1580	1627	1753
Length	mm	4792	4792	4792	4508	4508	4750
WEIGHT							
Unit Weight	kg	5790	5820	6220	6890	7260	8260
Operating Weight	kg	6220	6290	6690	7480	7830	9070
HEAT EXCHANGER - EVAPORATOR							
Type *		Flooded S&T	Flooded S&T	Flooded S&T	Flooded S&T	Flooded S&T	Flooded S&T
Fluid		Water	Water	Water	Water	Water	Water
Fouling Factor	m ² °C /W	0	0	0	0	0	0
Water Volume	l	230	270	270	320	320	380
Water temperature in	°C	12	12	12	12	12	12
Water temperature out	°C	7	7	7	7	7	7
Water flow rate	l/s	45.0	48.4	54.6	60.8	66.8	72.9
Water pressure drop	kPa	46.0	39.0	50.0	44.0	53.0	45.0
HEAT EXCHANGER - CONDENSER							
Type *		S&T	S&T	S&T	S&T	S&T	S&T
Fluid		Water	Water	Water	Water	Water	Water
Fouling Factor	m ² °C /W	0	0	0	0	0	0
Water Volume	l	200	200	200	270	250	430
Water temperature in	°C	30	30	30	30	30	30
Water temperature out	°C	35	35	35	35	35	35
Water flow rate	l/s	54.8	59.0	66.8	74.0	81.4	88.7
Water pressure drop	kPa	22.0	25.0	38.0	25.0	32.0	18.0
COMPRESSOR							
Oil charge	l	72.0	72.0	86.0	86.0	100	100
Quantity	No.	2	2	2	2	2	2
SOUND LEVEL**							
Sound Power - Cooling	dB(A)	106	107	107	108	108	110
Sound Pressure level@1m distance - Cooling	dB(A)	87	88	88	89	89	90
REFRIGERANT CIRCUIT							
Refrigerant type		R1234ze	R1234ze	R1234ze	R1234ze	R1234ze	R1234ze
Refrigerant charge	kg	260	290	290	320	320	350
N. of circuits	No.	2	2	2	2	2	2
PIPING CONNECTIONS							
Evaporator water inlet/outlet	mm	219.1	219.1	219.1	219.1	219.1	219.1
Condenser water inlet/outlet	mm	168.3/168.3	168.3/168.3	168.3/168.3	219.1/219.1	219.1/219.1	219.1/219.1

All the performances (Cooling capacity, unit power input and EER) are based on the following conditions: evaporator 12.0/7.0°C; condenser 30.0/35.0°C, unit at full load operation; operating fluid: Water; fouling factor = 0. S&T: Single Pass Shell & Tube; CC: Closed Cell; (**) The values are according to ISO 3744 and are referred to: evaporator 12/7° C, condenser 30/35° C, full load operation. The minimum capacity indicated is referred to unit operating at standard Eurovent conditions. Dimensions and weights are for indication only and not considered binding. Before designing the installation, consult the official drawings available from the factory at request. All the data are referred to standard unit without options. All data are subject to change without notice. (***) The value refers to the pressure drops in the evaporator/condenser only). (****) In accordance with standard EN14825:2013, comfort low temperature, average climate. SEER and η_s values applicable Ecodesign regulation: (EU) No 2016/2281.

Eurovent certified values

EWWH~VZ-XS

MODEL		EWWH335V ZXSA1	EWWH365V ZXSA1	EWWH450V ZXSA1	EWWH525V ZXSA1	EWWH580V ZXSA1	EWWH670V ZXSA1
COOLING PERFORMANCE							
Capacity - Cooling	kW	329	365	448	521	579	665
Capacity control - Type		Stepless	Stepless	Stepless	Stepless	Stepless	Stepless
Capacity control - Minimum capacity	%	20	20	20	20	20	20
Unit power input - Cooling	kW	60.5	66.6	81.0	96.0	109	121
EER		5.44	5.48	5.53	5.42	5.29	5.49
ESEER		7.14	7.56	8.32	8.32	8.34	8.46
IPLV		8.51	8.79	9.46	9.51	9.47	9.63
SEASONAL ENERGY EFFICIENCY ****							
SEER (12/7°C)		7.6	7.88	8.79	8.88	8.78	9.1
$\eta_{s\ cool}(12/7^\circ C)$	%	296	307.2	343.6	347.2	343.2	356
DIMENSIONS							
Height	mm	2135	2135	2123	2235	2235	2487
Width	mm	1178	1178	1179	1189	1189	1303
Length	mm	3722	3722	3750	3690	3690	3822
WEIGHT							
Unit Weight	kg	2968	2911	3102	3470	3451	4257
Operating Weight	kg	3098	3006	3274	3648	3611	4518
HEAT EXCHANGER - EVAPORATOR							
Type *		Flooded S&T	Flooded S&T	Flooded S&T	Flooded S&T	Flooded S&T	Flooded S&T
Fluid		Water	Water	Water	Water	Water	Water
Fouling Factor	m ² °C /W	0	0	0	0	0	0
Water Volume	l	70	88	136	134	134	168
Water temperature in	°C	12	12	12	12	12	12
Water temperature out	°C	7	7	7	7	7	7
Water flow rate	l/s	15.8	17.5	21.4	24.9	27.7	31.8
Water pressure drop	kPa	54.0	38.0	35.0	37.0	31.0	39.0
HEAT EXCHANGER - CONDENSER							
Type *		S&T	S&T	S&T	S&T	S&T	S&T
Fluid		Water	Water	Water	Water	Water	Water
Fouling Factor	m ² °C /W	0	0	0	0	0	0
Water Volume	l	81	92	126	145	126	217
Water temperature in	°C	30	30	30	30	30	30
Water temperature out	°C	35	35	35	35	35	35
Water flow rate	l/s	18.9	20.9	25.7	30.0	33.5	38.4
Water pressure drop	kPa	19.0	16.0	13.0	12.0	15.0	13.0
COMPRESSOR							
Oil charge	l	32.0	32.0	36.0	36.0	50.0	50.0
Quantity	No.	1	1	1	1	1	1
SOUND LEVEL **							
Sound Power - Cooling	dB(A)	97	99	101	105	105	105
Sound Pressure level@1m distance - Cooling	dB(A)	78	80	82	86	86	86
REFRIGERANT CIRCUIT							
Refrigerant type		R1234ze	R1234ze	R1234ze	R1234ze	R1234ze	R1234ze
Refrigerant charge	kg	95	95	100	110	170	170
N. of circuits	No.	1	1	1	1	1	1
PIPING CONNECTIONS							
Evaporator water inlet/outlet	mm	139.7	139.7	139.7	168.3	168.3	219.1
Condenser water inlet/outlet	mm	168.3	168.3	219.1	219.1	219.1	219.1

All the performances (Cooling capacity, unit power input and EER) are based on the following conditions: evaporator 12.0/7.0°C; condenser 30.0/35.0°C, unit at full load operation; operating fluid: Water; fouling factor = 0. S&T: Single Pass Shell & Tube; CC: Closed Cell; (**) The values are according to ISO 3744 and are referred to: evaporator 12/7° C, condenser 30/35° C, full load operation. The minimum capacity indicated is referred to unit operating at standard Eurovent conditions. Dimensions and weights are for indication only and not considered binding. Before designing the installation, consult the official drawings available from the factory at request. All the data are referred to standard unit without options. All data are subject to change without notice. (***) The value refers to the pressure drops in the evaporator/condenser only). (****) In accordance with standard EN14825:2013, comfort low temperature, average climate. SEER and η_s values applicable Ecodesign regulation: (EU) No 2016/2281.

Eurovent certified values

EWWH~VZ-XS

MODEL		EWWH800V ZXSA1	EWWH875V ZXSA2	EWWH950V ZXSA2	EWWHC11V ZXSA2	EWWHC12V ZXSA2	EWWHC13V ZXSA2
COOLING PERFORMANCE							
Capacity - Cooling	kW	788	877	952	1,029	1,169	1,288
Capacity control - Type		Stepless	Stepless	Stepless	Stepless	Stepless	Stepless
Capacity control - Minimum capacity	%	20	10	10	10	10	10
Unit power input - Cooling	kW	146	167	184	198	224	248
EER		5.37	5.23	5.16	5.19	5.22	5.19
ESEER		8.55	8.26	8.26	8.50	8.54	8.81
IPLV		9.65	9.19	9.27	9.46	9.37	9.52
SEASONAL ENERGY EFFICIENCY ****							
SEER (12/7°C)		9.06	8.35	8.55	8.87	8.87	8.87
$\eta_{s\ cool}(12/7°C)$	%	354.4	326	334	346.8	346.8	346.8
DIMENSIONS							
Height	mm	2487	2296	2296	2301	2350	2500
Width	mm	1303	1484	1639	1579	1580	1610
Length	mm	3822	4792	4792	4508	4508	4750
WEIGHT							
Unit Weight	kg	4552	5860	6240	6520	6920	7530
Operating Weight	kg	4860	6370	6760	7130	7530	8300
HEAT EXCHANGER - EVAPORATOR							
Type *		Flooded S&T	Flooded S&T	Flooded S&T	Flooded S&T	Flooded S&T	Flooded S&T
Fluid		Water	Water	Water	Water	Water	Water
Fouling Factor	m ² °C /W	0	0	0	0	0	0
Water Volume	l	199	270	270	320	320	380
Water temperature in	°C	12	12	12	12	12	12
Water temperature out	°C	7	7	7	7	7	7
Water flow rate	l/s	37.7	41.9	45.5	49.1	55.9	61.6
Water pressure drop	kPa	36.0	29.0	34.0	28.0	37.0	32.0
HEAT EXCHANGER - CONDENSER							
Type *		S&T	S&T	S&T	S&T	S&T	S&T
Fluid		Water	Water	Water	Water	Water	Water
Fouling Factor	m ² °C /W	0	0	0	0	0	0
Water Volume	l	241	240	250	290	290	390
Water temperature in	°C	30	30	30	30	30	30
Water temperature out	°C	35	35	35	35	35	35
Water flow rate	l/s	45.7	50.7	55.1	59.6	67.6	74.6
Water pressure drop	kPa	16.0	16.0	16.0	13.0	19.0	16.0
COMPRESSOR							
Oil charge	l	50.0	68.0	72.0	72.0	86.0	86.0
Quantity	No.	1	2	2	2	2	2
SOUND LEVEL**							
Sound Power - Cooling	dB(A)	107	106	106	107	107	108
Sound Pressure level@1m distance - Cooling	dB(A)	88	87	87	88	88	89
REFRIGERANT CIRCUIT							
Refrigerant type		R1234ze	R1234ze	R1234ze	R1234ze	R1234ze	R1234ze
Refrigerant charge	kg	180	250	260	290	290	320
N. of circuits	No.	1	2	2	2	2	2
PIPING CONNECTIONS							
Evaporator water inlet/outlet	mm	219.1	219.1	219.1	219.1	219.1	219.1
Condenser water inlet/outlet	mm	219.1	168.3/219.1	219.1/219.1	219.1/219.1	219.1/219.1	219.1/219.1

All the performances (Cooling capacity, unit power input and EER) are based on the following conditions: evaporator 12.0/7.0°C; condenser 30.0/35.0°C, unit at full load operation; operating fluid: Water; fouling factor = 0. S&T: Single Pass Shell & Tube; CC: Closed Cell; (**) The values are according to ISO 3744 and are referred to: evaporator 12/7° C, condenser 30/35° C, full load operation. The minimum capacity indicated is referred to unit operating at standard Eurovent conditions. Dimensions and weights are for indication only and not considered binding. Before designing the installation, consult the official drawings available from the factory at request. All the data are referred to standard unit without options. All data are subject to change without notice. (***) The value refers to the pressure drops in the evaporator/condenser only). (****) In accordance with standard EN14825:2013, comfort low temperature, average climate. SEER and η_s values applicable Ecodesign regulation: (EU) No 2016/2281.

Eurovent certified values

EWWH~VZ-XS

MODEL		EWWHC14V ZXSA2	EWWHC15V ZXSA2
COOLING PERFORMANCE			
Capacity - Cooling	kW	1,422	1,540
Capacity control - Type		Stepless	Stepless
Capacity control - Minimum capacity	%	10	10
Unit power input - Cooling	kW	275	298
EER		5.16	5.16
ESEER		8.61	8.72
IPLV		9.23	9.50
SEASONAL ENERGY EFFICIENCY ****			
SEER (12/7°C)		9.15	9.12
$\eta_{s\ cool}(12/7^\circ C)$	%	358	356.8
DIMENSIONS			
Height	mm	2469	2493
Width	mm	1704	1769
Length	mm	4874	4874
WEIGHT			
Unit Weight	kg	7790	8670
Operating Weight	kg	8560	9630
HEAT EXCHANGER - EVAPORATOR			
Type *		Flooded S&T	Flooded S&T
Fluid		Water	Water
Fouling Factor	m ² °C /W	0	0
Water Volume	l	480	480
Water temperature in	°C	12	12
Water temperature out	°C	7	7
Water flow rate	l/s	67.9	73.6
Water pressure drop	kPa	28.0	33.0
HEAT EXCHANGER - CONDENSER			
Type *		S&T	S&T
Fluid		Water	Water
Fouling Factor	m ² °C /W	0	0
Water Volume	l	290	480
Water temperature in	°C	30	30
Water temperature out	°C	35	35
Water flow rate	l/s	82.3	89.3
Water pressure drop	kPa	23.0	16.0
COMPRESSOR			
Oil charge	l	100	100
Quantity	No.	2	2
SOUND LEVEL**			
Sound Power - Cooling	dB(A)	109	110
Sound Pressure level@1m distance - Cooling	dB(A)	89	90
REFRIGERANT CIRCUIT			
Refrigerant type		R1234ze	R1234ze
Refrigerant charge	kg	320	350
N. of circuits	No.	2	2
PIPING CONNECTIONS			
Evaporator water inlet/outlet	mm	273	273
Condenser water inlet/outlet	mm	219.1/219.1	219.1/219.1

All the performances (Cooling capacity, unit power input and EER) are based on the following conditions: evaporator 12.0/7.0°C; condenser 30.0/35.0°C, unit at full load operation; operating fluid: Water; fouling factor = 0. S&T: Single Pass Shell & Tube; CC: Closed Cell; (**) The values are according to ISO 3744 and are referred to: evaporator 12/7° C, condenser 30/35° C, full load operation. The minimum capacity indicated is referred to unit operating at standard Eurovent conditions. Dimensions and weights are for indication only and not considered binding. Before designing the installation, consult the official drawings available from the factory at request. All the data are referred to standard unit without options. All data are subject to change without notice. (***) The value refers to the pressure drops in the evaporator/condenser only). (****) In accordance with standard EN14825:2013, comfort low temperature, average climate. SEER and η_s values applicable Ecodesign regulation: (EU) No 2016/2281.

Eurovent certified values

EWWH~VZ-PS

MODEL		EWWH370V ZPSA1	EWWH530V ZPSA1	EWWH680V ZPSA1	EWWH880V ZPSA2	EWWHC12V ZPSA2	EWWHC13V ZPSA2
COOLING PERFORMANCE							
Capacity - Cooling	kW	369	525	677	884	1,180	1,295
Capacity control - Type		Stepless	Stepless	Stepless	Stepless	Stepless	Stepless
Capacity control - Minimum capacity	%	20	20	20	10	10	10
Unit power input - Cooling	kW	64.7	94.9	119	165	220	246
EER		5.71	5.53	5.67	5.34	5.35	5.25
ESEER		7.90	8.64	8.83	8.54	8.85	9.00
IPLV		9.13	9.68	9.96	9.37	9.56	9.61
SEASONAL ENERGY EFFICIENCY ****							
SEER (12/7°C)		8.12	9.02	9.29	8.56	9.01	8.92
$\eta_{s\ cool}(12/7°C)$	%	316.8	352.8	363.6	334.4	352.4	348.8
DIMENSIONS							
Height	mm	2108	2430	2487	2302	2500	2493
Width	mm	1179	1287	1303	1579	1610	1769
Length	mm	3750	3822	3822	4508	4750	4874
WEIGHT							
Unit Weight	kg	3247	4082	4346	6310	7530	8250
Operating Weight	kg	3375	4349	4660	6900	8300	9200
HEAT EXCHANGER - EVAPORATOR							
Type *		Flooded S&T	Flooded S&T	Flooded S&T	Flooded S&T	Flooded S&T	Flooded S&T
Fluid		Water	Water	Water	Water	Water	Water
Fouling Factor	m ² °C /W	0	0	0	0	0	0
Water Volume	l	96	168	199	320	380	480
Water temperature in	°C	12	12	12	12	12	12
Water temperature out	°C	7	7	7	7	7	7
Water flow rate	l/s	17.7	25.1	32.3	42.2	56.4	61.9
Water pressure drop	kPa	32.0	25.0	27.0	20.0	26.0	23.0
HEAT EXCHANGER - CONDENSER							
Type *		S&T	S&T	S&T	S&T	S&T	S&T
Fluid		Water	Water	Water	Water	Water	Water
Fouling Factor	m ² °C /W	0	0	0	0	0	0
Water Volume	l	126	217	241	270	390	470
Water temperature in	°C	30	30	30	30	30	30
Water temperature out	°C	35	35	35	35	35	35
Water flow rate	l/s	21.1	30.1	38.9	50.9	68.0	74.9
Water pressure drop	kPa	9.00	9.00	12.0	13.0	12.0	16.0
COMPRESSOR							
Oil charge	l	36.0	40.0	50.0	68.0	86.0	86.0
Quantity	No.	1	1	1	2	2	2
SOUND LEVEL **							
Sound Power - Cooling	dB(A)	99	105	105	106	107	109
Sound Pressure level@1m distance - Cooling	dB(A)	80	86	86	87	88	89
REFRIGERANT CIRCUIT							
Refrigerant type		R1234ze	R1234ze	R1234ze	R1234ze	R1234ze	R1234ze
Refrigerant charge	kg	100	150	180	290	320	350
N. of circuits	No.	1	1	1	2	2	2
PIPING CONNECTIONS							
Evaporator water inlet/outlet	mm	139.7	219.1	219.1	219.1	219.1	273
Condenser water inlet/outlet	mm	219.1	219.1	219.1	219.1/219.1	219.1/219.1	219.1/219.1

All the performances (Cooling capacity, unit power input and EER) are based on the following conditions: evaporator 12.0/7.0°C; condenser 30.0/35.0°C, unit at full load operation; operating fluid: Water; fouling factor = 0. S&T: Single Pass Shell & Tube; (**) The values are according to ISO 3744 and are referred to: evaporator 12/7° C, condenser 30/35° C, full load operation. The minimum capacity indicated is referred to unit operating at standard Eurovent conditions. Dimensions and weights are for indication only and not considered binding. Before designing the installation, consult the official drawings available from the factory at request. All the data are referred to standard unit without options. All data are subject to change without notice. (***) The value refers to the pressure drops in the evaporator/condenser only). (****) In accordance with standard EN14825:2013, comfort low temperature, average climate. SEER and η_s values applicable Ecodesign regulation: (EU) No 2016/2281.

Eurovent certified values

EWWH~VZ-SS

MODEL		EWWH445V ZSSA1	EWWH515V ZSSA1	EWWH550V ZSSA1	EWWH660V ZSSA1	EWWH770V ZSSA1	EWWH860V ZSSA2
POWER SUPPLY							
Phases	No.	3	3	3	3	3	3
Frequency	Hz	50	50	50	50	50	50
Voltage	V	400	400	400	400	400	400
Voltage tolerance Minimum	%	-10%	-10%	-10%	-10%	-10%	-10%
Voltage tolerance Maximum	%	10%	10%	10%	10%	10%	10%
UNIT							
Maximum inrush current	A	0	0	0	0	0	0
Nominal running current cooling	A	131	153	167	188	227	264
Maximum running current	A	213	246	265	277	404	445
Maximum current for wires sizing	A	234	270	291	305	444	490
COMPRESSORS							
Phases	No.	3	3	3	3	3	3
Voltage	V	400	400	400	400	400	400
Voltage tolerance Minimum	%	-10%	-10%	-10%	-10%	-10%	-10%
Voltage tolerance Maximum	%	10%	10%	10%	10%	10%	10%
Maximum running current	A	213	246	265	277	404	246
Starting method		VFD	VFD	VFD	VFD	VFD	VFD

MODEL		EWWH940V ZSSA2	EWWHC10V ZSSA2	EWWHC12V ZSSA2	EWWHC13V ZSSA2	EWWHC14V ZSSA2	EWWHC15V ZSSA2
POWER SUPPLY							
Phases	No.	3	3	3	3	3	3
Frequency	Hz	50	50	50	50	50	50
Voltage	V	400	400	400	400	400	400
Voltage tolerance Minimum	%	-10%	-10%	-10%	-10%	-10%	-10%
Voltage tolerance Maximum	%	10%	10%	10%	10%	10%	10%
UNIT							
Maximum inrush current	A	0	0	0	0	0	0
Nominal running current cooling	A	287	312	353	385	426	458
Maximum running current	A	458	491	523	649	744	807
Maximum current for wires sizing	A	504	541	575	714	818	888
COMPRESSORS							
Phases	No.	3	3	3	3	3	3
Voltage	V	400	400	400	400	400	400
Voltage tolerance Minimum	%	-10%	-10%	-10%	-10%	-10%	-10%
Voltage tolerance Maximum	%	10%	10%	10%	10%	10%	10%
Maximum running current	A	229	246	277	404	372	404
Starting method		VFD	VFD	VFD	VFD	VFD	VFD

Allowed voltage tolerance $\pm 10\%$. Voltage unbalance between phases must be within $\pm 3\%$. In case of inverter driven units, no inrush current at start up is experienced. Nominal running current in cooling is referred to the following conditions: evaporator 12/7°C; condenser 30/35°C. Maximum running current is based on max compressor absorbed current in its envelope. Maximum current for wires sizing is based on minimum allowed voltage. Maximum current for wires sizing: compressors full load ampere x 1,1. The data are referred to the standard unit without options. All data are subject to change without notice. Please refer to unit nameplate data.

EWWH~VZ-XS

MODEL		EWWH335V ZXSA1	EWWH365V ZXSA1	EWWH450V ZXSA1	EWWH525V ZXSA1	EWWH580V ZXSA1	EWWH670V ZXSA1
POWER SUPPLY							
Phases	No.	3	3	3	3	3	3
Frequency	Hz	50	50	50	50	50	50
Voltage	V	400	400	400	400	400	400
Voltage tolerance Minimum	%	-10%	-10%	-10%	-10%	-10%	-10%
Voltage tolerance Maximum	%	10%	10%	10%	10%	10%	10%
UNIT							
Maximum inrush current	A	0	0	0	0	0	0
Nominal running current cooling	A	96	106	129	151	173	187
Maximum running current	A	178	199	213	246	275	277
Maximum current for wires sizing	A	196	219	234	270	303	305
COMPRESSORS							
Phases	No.	3	3	3	3	3	3
Voltage	V	400	400	400	400	400	400
Voltage tolerance Minimum	%	-10%	-10%	-10%	-10%	-10%	-10%
Voltage tolerance Maximum	%	10%	10%	10%	10%	10%	10%
Maximum running current	A	178	199	213	246	275	277
Starting method		VFD	VFD	VFD	VFD	VFD	VFD

MODEL		EWWH800V ZXSA1	EWWH875V ZXSA2	EWWH950V ZXSA2	EWWHC11V ZXSA2	EWWHC12V ZXSA2	EWWHC13V ZXSA2
POWER SUPPLY							
Phases	No.	3	3	3	3	3	3
Frequency	Hz	50	50	50	50	50	50
Voltage	V	400	400	400	400	400	400
Voltage tolerance Minimum	%	-10%	-10%	-10%	-10%	-10%	-10%
Voltage tolerance Maximum	%	10%	10%	10%	10%	10%	10%
UNIT							
Maximum inrush current	A	0	0	0	0	0	0
Nominal running current cooling	A	226	259	284	304	341	379
Maximum running current	A	404	445	458	491	523	649
Maximum current for wires sizing	A	444	490	504	541	575	714
COMPRESSORS							
Phases	No.	3	3	3	3	3	3
Voltage	V	400	400	400	400	400	400
Voltage tolerance Minimum	%	-10%	-10%	-10%	-10%	-10%	-10%
Voltage tolerance Maximum	%	10%	10%	10%	10%	10%	10%
Maximum running current	A	404	246	229	246	277	404
Starting method		VFD	VFD	VFD	VFD	VFD	VFD

Fluid: Water;

Allowed voltage tolerance $\pm 10\%$. Voltage unbalance between phases must be within $\pm 3\%$. In case of inverter driven units, no inrush current at start up is experienced. Nominal running current in cooling is referred to the following conditions: evaporator 12/7°C; condenser 30/35°C. Maximum running current is based on max compressor absorbed current in its envelope. Maximum current for wires sizing is based on minimum allowed voltage. Maximum current for wires sizing: compressors full load ampere x 1,1. The data are referred to the standard unit without options. All data are subject to change without notice. Please refer to unit nameplate data.

EWWH~VZ-XS

MODEL		EWWHC14V ZXSA2	EWWHC15V ZXSA2
POWER SUPPLY			
Phases	No.	3	3
Frequency	Hz	50	50
Voltage	V	400	400
Voltage tolerance Minimum	%	-10%	-10%
Voltage tolerance Maximum	%	10%	10%
UNIT			
Maximum inrush current	A	0	0
Nominal running current cooling	A	421	454
Maximum running current	A	744	807
Maximum current for wires sizing	A	818	888
COMPRESSORS			
Phases	No.	3	3
Voltage	V	400	400
Voltage tolerance Minimum	%	-10%	-10%
Voltage tolerance Maximum	%	10%	10%
Maximum running current	A	372	404
Starting method		VFD	VFD

Fluid: Water;

Allowed voltage tolerance $\pm 10\%$. Voltage unbalance between phases must be within $\pm 3\%$. In case of inverter driven units, no inrush current at start up is experienced. Nominal running current in cooling is referred to the following conditions: evaporator 12/7°C; condenser 30/35°C. Maximum running current is based on max compressor absorbed current in its envelope. Maximum current for wires sizing is based on minimum allowed voltage. Maximum current for wires sizing: compressors full load ampere x 1,1. The data are referred to the standard unit without options. All data are subject to change without notice. Please refer to unit nameplate data.

EWWH~VZ-PS

MODEL		EWWH370V ZPSA1	EWWH530V ZPSA1	EWWH680V ZPSA1	EWWH880V ZPSA2	EWWHC12V ZPSA2	EWWHC13V ZPSA2
POWER SUPPLY							
Phases	No.	3	3	3	3	3	3
Frequency	Hz	50	50	50	50	50	50
Voltage	V	400	400	400	400	400	400
Voltage tolerance Minimum	%	-10%	-10%	-10%	-10%	-10%	-10%
Voltage tolerance Maximum	%	10%	10%	10%	10%	10%	10%
UNIT							
Maximum inrush current	A	0	0	0	0	0	0
Nominal running current cooling	A	104	150	185	257	338	378
Maximum running current	A	199	246	277	445	523	649
Maximum current for wires sizing	A	219	270	305	490	575	714
COMPRESSORS							
Phases	No.	3	3	3	3	3	3
Voltage	V	400	400	400	400	400	400
Voltage tolerance Minimum	%	-10%	-10%	-10%	-10%	-10%	-10%
Voltage tolerance Maximum	%	10%	10%	10%	10%	10%	10%
Maximum running current	A	199	246	277	246	277	404
Starting method		VFD	VFD	VFD	VFD	VFD	VFD

Fluid: Water;

Allowed voltage tolerance $\pm 10\%$. Voltage unbalance between phases must be within $\pm 3\%$. In case of inverter driven units, no inrush current at start up is experienced. Nominal running current in cooling is referred to the following conditions: evaporator 12/7°C; condenser 30/35°C. Maximum running current is based on max compressor absorbed current in its envelope. Maximum current for wires sizing is based on minimum allowed voltage. Maximum current for wires sizing: compressors full load ampere x 1,1. The data are referred to the standard unit without options. All data are subject to change without notice. Please refer to unit nameplate data.

EWWH~VZ-SS

MODEL	Sound pressure level at 1 m from the unit (rif. 2 x 10 ⁻⁵ Pa)									Power db(A)
	63 Hz	125 Hz	250 Hz	500 Hz	1000 Hz	2000 Hz	4000 Hz	8000 Hz	db(A)	
445	65.7	67.5	74.5	82.2	75.8	73.8	65.7	58.3	82	101
515	69.7	71.5	78.5	86.2	79.8	77.8	69.7	62.3	86	105
550	69.7	71.5	78.5	86.2	79.8	77.8	69.7	62.3	86	105
660	69.7	71.5	78.5	86.2	79.8	77.8	69.7	62.3	86	105
770	71.7	73.5	80.5	88.2	81.8	79.8	71.7	64.3	88	107
860	70.2	73.2	81.3	86.5	81.3	79.3	70.9	63.2	87	106
940	70.2	73.2	81.3	86.5	81.3	79.3	70.9	63.2	87	106
C10	71.7	73.5	80.5	88.2	81.8	79.8	71.7	64.3	88	107
C12	71.7	73.5	80.5	88.2	81.8	79.8	71.7	64.3	88	107
C13	72.7	74.5	81.5	89.2	82.8	80.8	72.7	65.3	89	108
C14	72.7	74.5	81.5	89.2	82.8	80.8	72.7	65.3	89	108
C15	73.7	75.5	82.5	90.2	83.8	81.8	73.7	66.3	90	110

The values are according to ISO 3744 and are referred to: evaporator 12/7° C, condenser 30/35° C, full load operation.
The sound data in the Octave band spectrum is for intended for reference only and not considering binding.
The data are referred to the standard unit without options.

EWWH~VZ-XS

MODEL	Sound pressure level at 1 m from the unit (rif. 2 x 10 ⁻⁵ Pa)									Power db(A)
	63 Hz	125 Hz	250 Hz	500 Hz	1000 Hz	2000 Hz	4000 Hz	8000 Hz	db(A)	
335	58.4	66.2	76.0	73.2	73.9	72.0	62.9	53.7	78	97
365	60.4	68.2	78.0	75.2	75.9	74.0	64.9	55.7	80	99
450	65.7	67.5	74.5	82.2	75.8	73.8	65.7	58.3	82	101
525	69.7	71.5	78.5	86.2	79.8	77.8	69.7	62.3	86	105
580	69.7	71.5	78.5	86.2	79.8	77.8	69.7	62.3	86	105
670	69.7	71.5	78.5	86.2	79.8	77.8	69.7	62.3	86	105
800	71.7	73.5	80.5	88.2	81.8	79.8	71.7	64.3	88	107
875	70.2	73.2	81.3	86.5	81.3	79.3	70.9	63.2	87	106
950	70.2	73.2	81.3	86.5	81.3	79.3	70.9	63.2	87	106
C11	71.7	73.5	80.5	88.2	81.8	79.8	71.7	64.3	88	107
C12	71.7	73.5	80.5	88.2	81.8	79.8	71.7	64.3	88	107
C13	72.7	74.5	81.5	89.2	82.8	80.8	72.7	65.3	89	108
C14	72.7	74.5	81.5	89.2	82.8	80.8	72.7	65.3	89	109
C15	73.7	75.5	82.5	90.2	83.8	81.8	73.7	66.3	90	110

The values are according to ISO 3744 and are referred to: evaporator 12/7° C, condenser 30/35° C, full load operation.
The sound data in the Octave band spectrum is for intended for reference only and not considering binding.
The data are referred to the standard unit without options.

EWWH~VZ-PS

MODEL	Sound pressure level at 1 m from the unit (rif. 2 x 10⁻⁵ Pa)								Power	
	63 Hz	125 Hz	250 Hz	500 Hz	1000 Hz	2000 Hz	4000 Hz	8000 Hz	db(A)	db(A)
370	60.4	68.2	78.0	75.2	75.9	74.0	64.9	55.7	80	99
530	69.7	71.5	78.5	86.2	79.8	77.8	69.7	62.3	86	105
680	69.7	71.5	78.5	86.2	79.8	77.8	69.7	62.3	86	105
880	70.2	73.2	81.3	86.5	81.3	79.3	70.9	63.2	87	106
C12	71.7	73.5	80.5	88.2	81.8	79.8	71.7	64.3	88	107
C13	72.7	74.5	81.5	89.2	82.8	80.8	72.7	65.3	89	109

*The values are according to ISO 3744 and are referred to: evaporator 12/7° C, condenser 30/35° C, full load operation.
 The sound data in the Octave band spectrum is for intended for reference only and not considering binding.
 The data are referred to the standard unit without options.*

Operating Limits

EWWH-VZSS - Silver Version

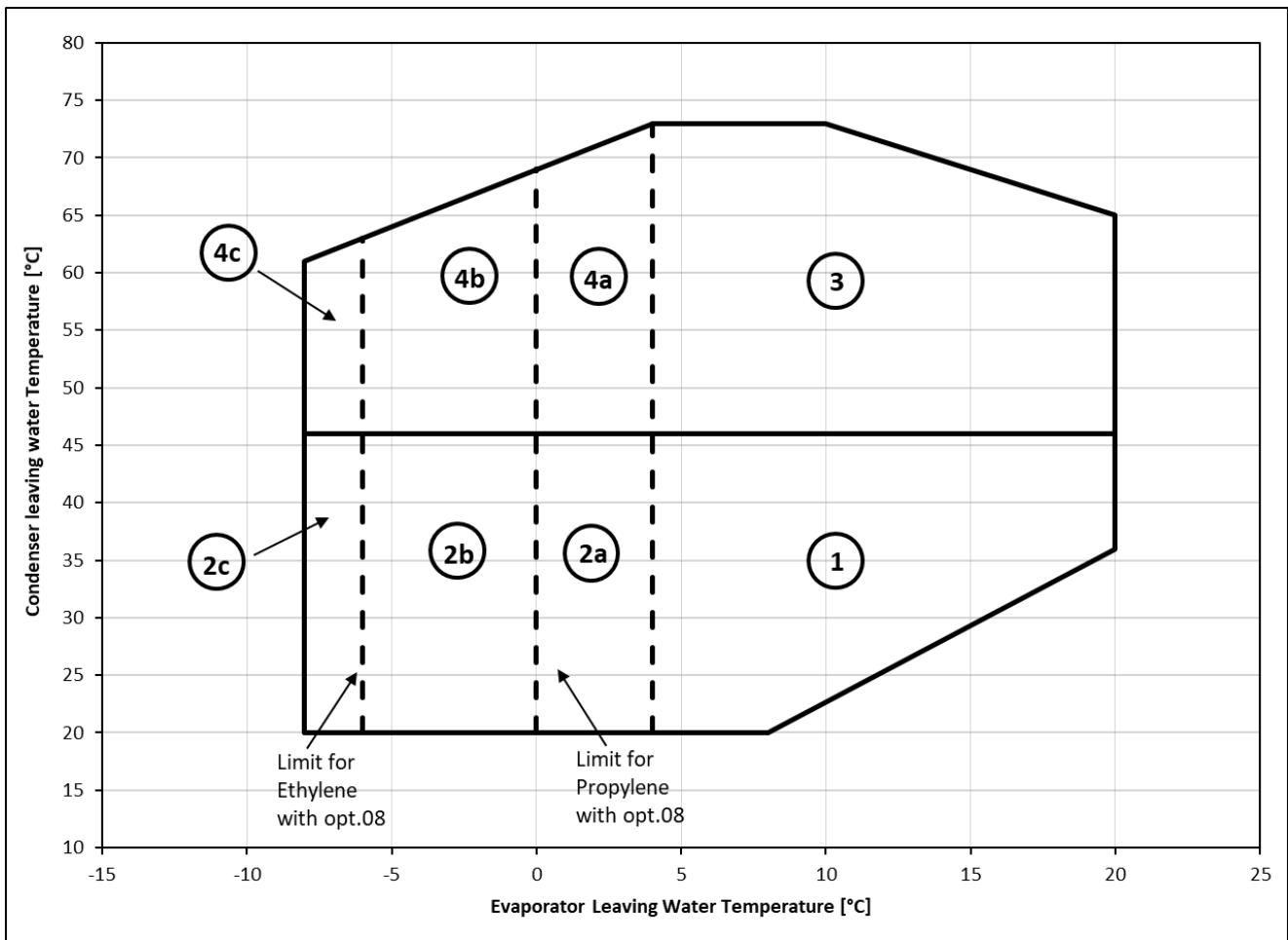

Legend:

ELWT: Evaporator Leaving Water Temperature (°C) CLWT: Condenser Leaving Water Temperature (°C)

Ref. 1: Standard Unit (no options are required to operate in this area).

Ref. 2a: Standard Unit plus Brine Version (option 08 - on request). Limit for Propylene Glycol: ELWT = 0°C

Ref. 2b: Standard Unit plus Brine Version (option 08 - on request). Limit for Ethylene Glycol: ELWT = -6°C

Ref. 2c: Standard Unit plus Low Brine Version (option 174 - on request).

Ref. 3: Standard Unit plus High temperature kit (option 111 - on request).

Ref. 4a: Standard Unit plus High temperature kit (option 111 - on request) plus Brine Version (option 08 - on request). Limit for Propylene Glycol: ELWT = 0°C

Ref. 4b: Standard Unit plus High temperature kit (option 111 - on request) plus Brine Version (option 08 - on request). Limit for Ethylene Glycol: ELWT = -6°C

Ref. 4c: Standard Unit plus High temperature kit (option 111 - on request) plus Low Brine Version (option 174 - on request).

Note: Unit selected with opt.174 either opt.111 needs to be ordered with such options. Is not possible on site to retrofit units with op.174/11.

Operating Limits

EWWH-VZXS & EWWH-VZPS - Gold & Platinum Version

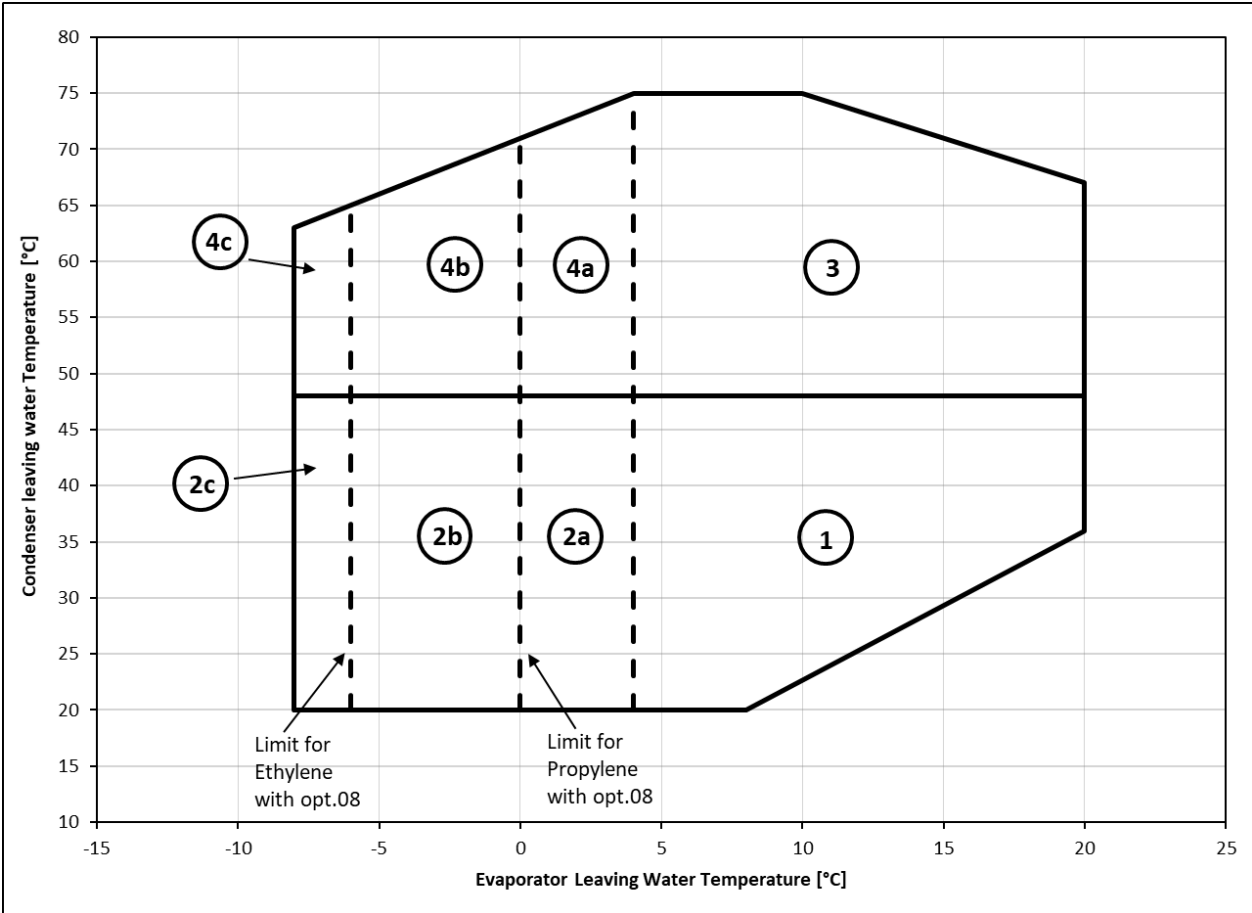

Legend:

ELWT: Evaporator Leaving Water Temperature (°C) CLWT: Condenser Leaving Water Temperature (°C)

Ref. 1: Standard Unit (no options are required to operate in this area).

Ref. 2a: Standard Unit plus Brine Version (option 08 - on request). Limit for Propylene Glycol: ELWT = 0°C

Ref. 2b: Standard Unit plus Brine Version (option 08 - on request). Limit for Ethylene Glycol: ELWT = -6°C

Ref. 2c: Standard Unit plus Low Brine Version (option 174 - on request).

Ref. 3: Standard Unit plus High temperature kit (option 111 - on request).

Ref. 4a: Standard Unit plus High temperature kit (option 111 - on request) plus Brine Version (option 08 - on request). Limit for Propylene Glycol: ELWT = 0°C

Ref. 4b: Standard Unit plus High temperature kit (option 111 - on request) plus Brine Version (option 08 - on request). Limit for Ethylene Glycol: ELWT = -6°C

Ref. 4c: Standard Unit plus High temperature kit (option 111 - on request) plus Low Brine Version (option 174 - on request).

Note: Unit selected with opt.174 either opt.111 needs to be ordered with such options. Is not possible on site to retrofit units with op.174/111.

Notes:

- The above graph refers to the unit operating at full load. Unit may be able to operate outside the above envelope with compressors unloading. Please contact factory for further details.
- For operation with EWLWT below 4°C, the unit must operate with glycol mixture. The glycol percentage must be provided according to the minimum ELWT needed.
- The above graphic represents a guideline about the operating limits of the range. Please refer to the latest Chiller Selection Software (CSS) for real operating limits working conditions for each size.
- In areas 2, 3 and 4 chiller may not unload to the minimum capacity. Please refer to chiller selection software.

Water heat exchangers - maximum/maximum water Δt

The minimum and maximum allowed Δt at full load standard conditions are respectively 4°C and 8°C. These values represent a guideline, please refer to the latest Chiller Selection Software (CSS) for real minimum and maximum allowed Δt each size. Contact factory in case lower or higher Δt are required.

Requirements for operation and storage

Unit is designed for indoor installation only.

Environmental conditions must be within the following limits:

Limits for operation:

- Maximum ambient temperature: 42°C
- Minimum ambient temperature: 5°C
- Maximum relative humidity: 95% not condensing

Limits for storage:

- Maximum ambient temperature 50°C
- Minimum ambient temperature: - 20°C
- Maximum relative humidity: 95% not condensing

Storage below the minimum temperature may cause damage to components. Storage above the maximum temperature causes opening of safety valves.

Storage in condensing atmosphere may damage electronic components.

Water treatment

Before putting the unit into operation, clean the water circuit. Dirt, scales, corrosion debris and other materials can accumulate inside the heat exchanger and reduce its heat exchanging capacity. Pressure drops can increase as well, thus reducing water flow. Proper water treatment therefore reduces the risk of corrosion, erosion, scaling, etc.. The most appropriate water treatment must be determined locally, according to the type of system and water characteristics. The manufacturer is not responsible for damage to or malfunctioning of equipment caused by improperly treated water.

Water charge, flow and quality

Items to be certified:	Cooling System			Once Flow		Cooled Water		Heated water (1)		Tendency if out of criteria
	Circulating water		Supply water (1)	Flowing water	Circulating water	Supply water (1)	Low temperature	High temperature	Supply water (1)	
	Circulating water	Supply water (1)	Supply water (1)	Flowing water	Circulating water [Below 20°C]	Supply water (1)	Circulating water [20°C ~ 50°C]	Supply water (1)	Circulating water [50°C ~ 80°C]	
pH	6.5 ~ 8.2	6.0 ~ 8.0	6.0 ~ 8.0	6.0 ~ 8.0	6.0 ~ 8.0	6.0 ~ 8.0	7.0 ~ 8.0	7.0 ~ 8.0	7.0 ~ 8.0	Corrosion + Scale
Electrical conductivity	[ns/cm] at 25°C Below 80	Below 30	Below 40	Below 40	Below 80	Below 80	Below 30	Below 30	Below 30	Corrosion + Scale
	[µS/cm] at 25°C (Below 800)	(Below 300)	(Below 400)	(Below 400)	(Below 800)	(Below 800)	(Below 300)	(Below 300)	(Below 300)	Corrosion + Scale
Chloride Ion	[mgCl ⁻ /l] Below 200	Below 50	Below 50	Below 50	Below 200	Below 50	Below 50	Below 50	Below 30	Corrosion
Sulfate Ion	[mgSO ⁴⁻² /l] Below 200	Below 50	Below 50	Below 50	Below 200	Below 50	Below 50	Below 50	Below 30	Corrosion
Alkalinity (pH, δ)	[mgCaCO ₃ /l] Below 100	Below 50	Below 50	Below 50	Below 100	Below 50	Below 50	Below 50	Below 50	Scale
Total hardness	[mgCaCO ₃ /l] Below 200	Below 70	Below 70	Below 70	Below 200	Below 70	Below 70	Below 70	Below 70	Scale
Calcium hardness	[mgCaCO ₃ /l] Below 150	Below 50	Below 50	Below 50	Below 50	Below 50	Below 50	Below 50	Below 50	Scale
Silica Ion	[mgSiO ₂ /l] Below 50	Below 30	Below 30	Below 30	Below 30	Below 30	Below 30	Below 30	Below 30	Scale
Oxygen	[mgO ₂ /l] Below 1.0	Below 1.0	Below 1.0	Below 1.0	Below 1.0	Below 1.0	Below 1.0	Below 1.0	Below 1.0	Corrosion
Particulate size	(mm) Below 0.5	Below 0.5	Below 0.5	Below 0.5	Below 0.5	Below 0.6	Below 0.5	Below 0.5	Below 0.6	Erosion
Total dissolved solids	(mg/l) Below 1000	Below 1000	Below 1000	Below 1000	Below 1000	Below 1001	Below 1000	Below 1000	Below 1001	Erosion
Ethylene Glycol (weight conc.)	Below 60%	Below 60%	---	---	Below 60%	Below 60%	Below 60%	Below 60%	Below 60%	---
Nitrate Ion	(mg NO ₃ ⁻ /l) Below 100	Below 100	Below 100	Below 100	Below 100	Below 101	Below 100	Below 101	Below 101	Corrosion
TOC Total organic carbon	(mg/l) Below 1.0	Below 1.0	Below 1.0	Below 1.0	Below 1.0	Below 1.0	Below 1.0	Below 1.0	Below 1.0	Scale
Iron	[mgFe/l] Below 1.0	Below 0.3	Below 1.0	Below 1.0	Below 1.0	Below 0.3	Below 1.0	Below 1.0	Below 0.3	Corrosion + Scale
Copper	[mgCu/l] Below 0.3	Below 0.1	Below 1.0	Below 1.0	Below 1.0	Below 0.1	Below 1.0	Below 1.0	Below 0.1	Corrosion
Sulfite Ion	[mgS ²⁻ /l] Not detectable	Not detectable	Not detectable	Not detectable	Not detectable	Not detectable	Not detectable	Not detectable	Not detectable	Corrosion
Ammonium Ion	[mgNH ⁺ ₄ /l] Below 1.0	Below 0.1	Below 1.0	Below 1.0	Below 1.0	Below 0.1	Below 0.3	Below 0.1	Below 0.1	Corrosion
Remineralizer	[mgOL/l] Below 0.3	Below 0.3	Below 0.3	Below 0.3	Below 0.3	Below 0.3	Below 0.25	Below 0.1	Below 0.1	Corrosion
Free chlorine	[mgCl ₂ /l] Below 4.0	Below 4.0	Below 4.0	Below 4.0	Below 4.0	Below 4.0	Below 0.4	Below 0.4	Below 0.4	Corrosion
Stability Index	6.0 ~ 7.0	---	---	---	---	---	---	---	---	Corrosion + Scale

1 Names, definitions and units are according to JIS K 0101. Units and figures between brackets are old units published as reference only.

2 In case of using heated water (more than 40°C), corrosion is generally noticeable.

3 In the cooling water using hermetic cooling tower, close circuit water is according to heated water standard, and scattered water is according to cooling water standard.

4 Supply water is considered drink water, industrial water and ground water except for genuine water, neutral water and soft water.

5 The above mentioned items are representative items in corrosion and scale cases.

6 The limits above have to be considered as a general prescription and cannot totally assure the absence of corrosion and erosion.

Some particular combinations of elements or the presence of components not listed in the table or factors not considered may trigger corrosion phenomena.

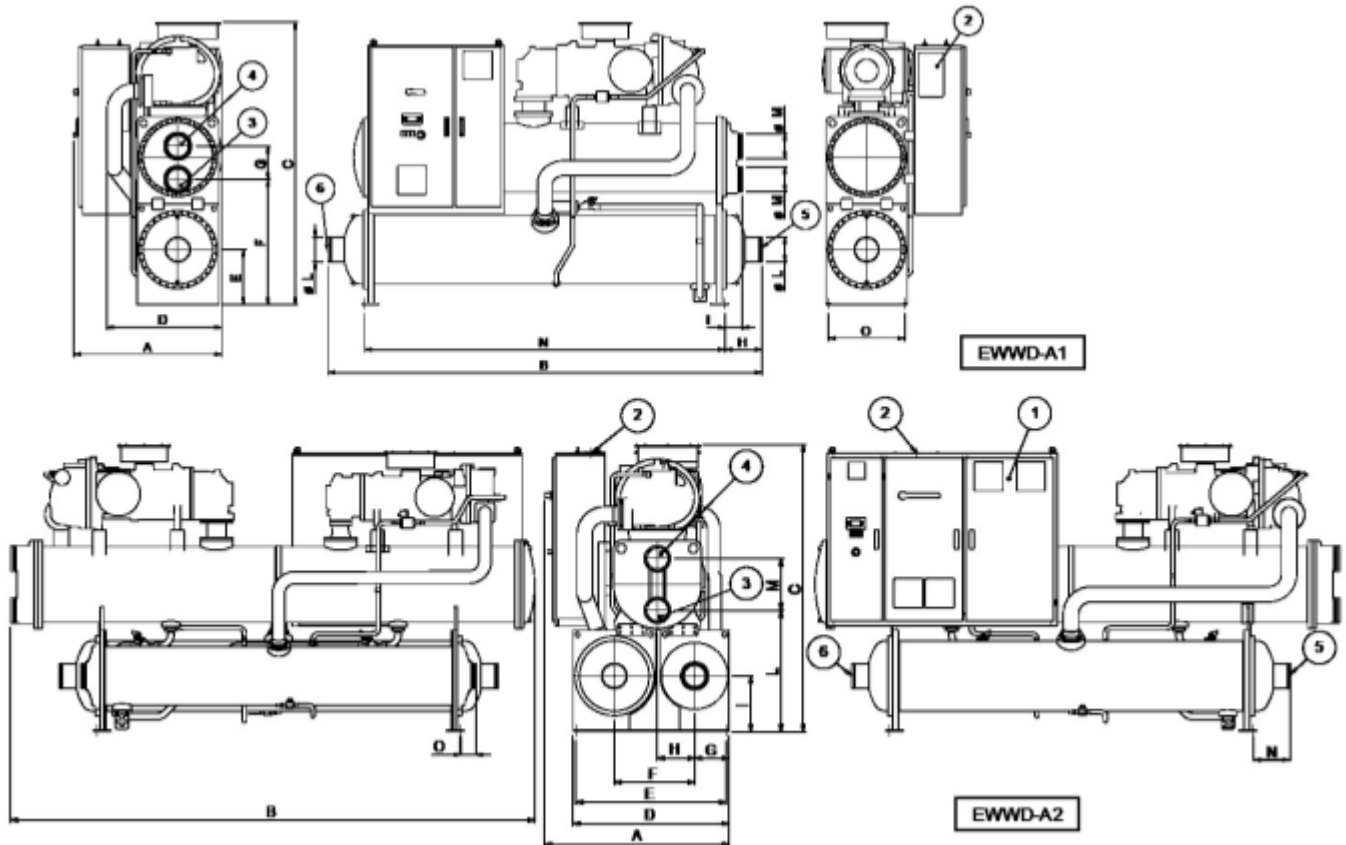

LEGEND

- 1. ELECTRICAL PANEL
- 2. POWER SUPPLY CABLE ENTRY
- 3. EVAPORATOR WATER INLET
- 4. EVAPORATOR WATER OUTLET
- 5. CONDENSER WATER INLET
- 6. CONDENSER WATER OUTLET

Unit dimensions below are in mm - note: the above drawings are not contractually binding. For the design of installation refer to the dedicated dimensional drawing available from the factory on request. The data are subject to change without notice.

MODEL	A	B	C
EWWH445VZSSA1	1178	3722	2123
EWWH515VZSSA1	1179	3750	2123
EWWH550VZSSA1	1179	3750	2123
EWWH660VZSSA1	1233	3690	2292
EWWH770VZSSA1	1303	3822	2487
EWWH860VZSSA2	1484	4792	2296
EWWH940VZSSA2	1487	4792	2296
EWWHC10VZSSA2	1487	4792	2296
EWWHC12VZSSA2	1484	4792	2296
EWWHC13VZSSA2	1580	4508	2350
EWWHC14VZSSA2	1627	4508	2338
EWWHC15VZSSA2	1753	4750	2498

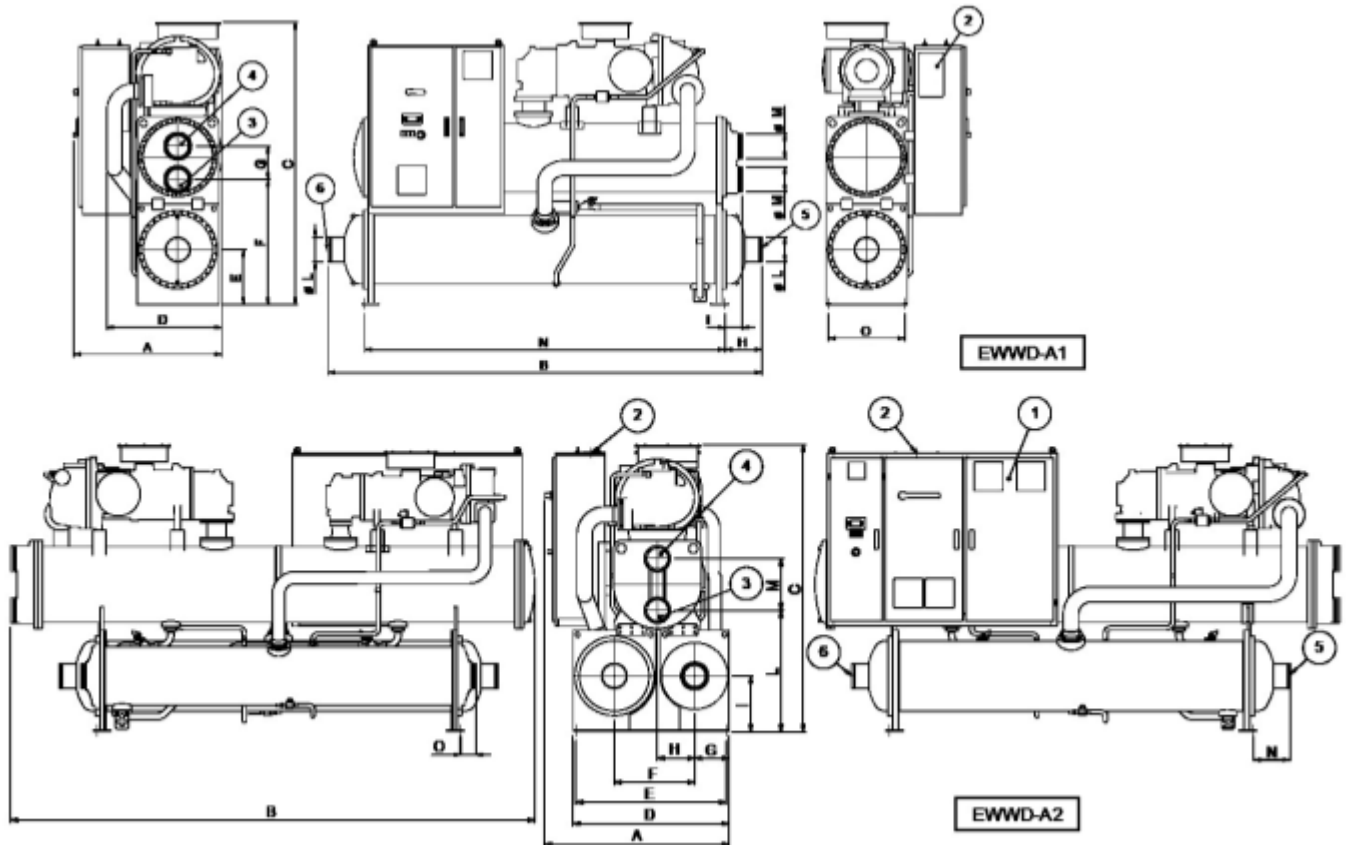

LEGEND

- 1. ELECTRICAL PANEL
- 2. POWER SUPPLY CABLE ENTRY
- 3. EVAPORATOR WATER INLET
- 4. EVAPORATOR WATER OUTLET
- 5. CONDENSER WATER INLET
- 6. CONDENSER WATER OUTLET

Unit dimensions below are in mm- note: the above drawings are not contractually binding. For the design of installation refer to the dedicated dimensional drawing available from the factory on request. The data are subject to change without notice.

MODEL	A	B	C
EWWH335VZXA1	1178	3722	2135
EWWH365VZXA1	1178	3722	2135
EWWH450VZXA1	1179	3750	2123
EWWH525VZXA1	1189	3690	2235
EWWH580VZXA1	1189	3690	2235
EWWH670VZXA1	1303	3822	2487
EWWH800VZXA1	1303	3822	2487
EWWH875VZXA2	1484	4792	2296
EWWH950VZXA2	1639	4792	2296
EWWHC11VZXA2	1579	4508	2301
EWWHC12VZXA2	1580	4508	2350
EWWHC13VZXA2	1610	4750	2500
EWWHC14VZXA2	1704	4874	2469
EWWHC15VZXA2	1769	4874	2493

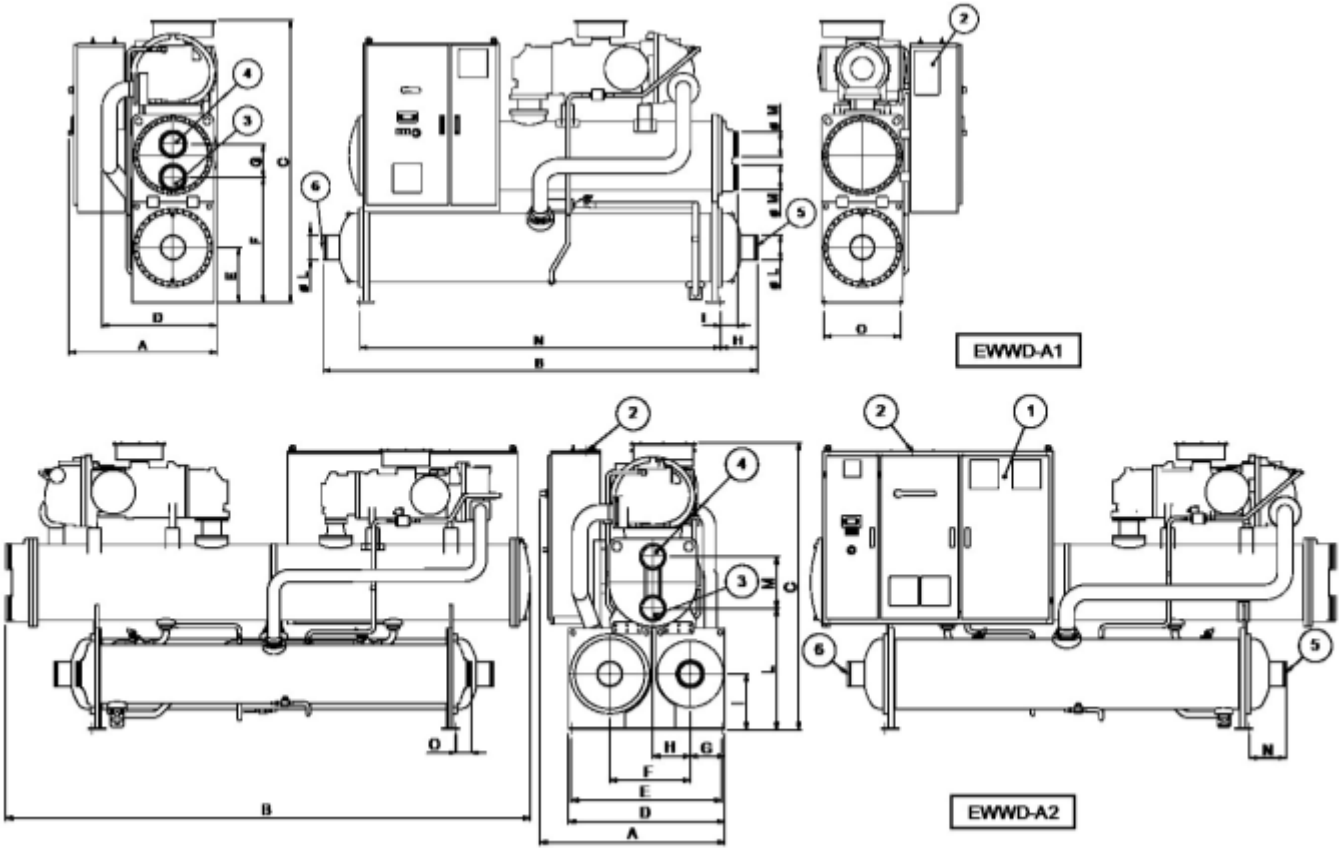

LEGEND

- 1. ELECTRICAL PANEL
- 2. POWER SUPPLY CABLE ENTRY
- 3. EVAPORATOR WATER INLET
- 4. EVAPORATOR WATER OUTLET
- 5. CONDENSER WATER INLET
- 6. CONDENSER WATER OUTLET

Unit dimensions below are in mm- note: the above drawings are not contractually binding. For the design of installation refer to the dedicated dimensional drawing available from the factory on request. The data are subject to change without notice.

MODEL	A	B	C
EWWH370VZPSA1	1179	3750	2108
EWWH530VZPSA1	1287	3822	2430
EWWH680VZPSA1	1303	3822	2487
EWWH880VZPSA2	1579	4508	2302
EWWHC12VZPSA2	1610	4750	2500
EWWHC13VZPSA2	1769	4874	2493

Installation Notes

Warning Installation and maintenance of the unit must be performed only by qualified personnel who have knowledge with local codes and regulations, and experience with this type of equipment. Must be avoided the unit installation in places that could be considered dangerous for all the maintenance operations.

Handling Avoid bumping and/or jolting during loading/unloading unit from the truck and moving it. Secure the unit inside the truck to prevent it from moving and causing damages. Do not allow any part of the unit to fall during transportation or loading/unloading.

Use extreme caution when handling the unit to prevent damage to the control or the refrigerant piping. The unit must be lifted by attaching cables or chains at the lifting holes in each corner. For more information please refer to the unit Installation Manual.

Location Unit is designed for indoor installation only. The unit must be mounted on a leveled base of concrete or steel. The unit must be installed on a robust and perfectly leveled foundation; it might be necessary to use weight distribution beams. Rubber mounts/pads as well as vibration isolators in all water piping connected to the chiller are recommended to avoid transmission of vibration and noise.

Space requirements Every side of the machine must be accessible for all post installation maintenance activities. The minimum space required is shown on the following drawing:

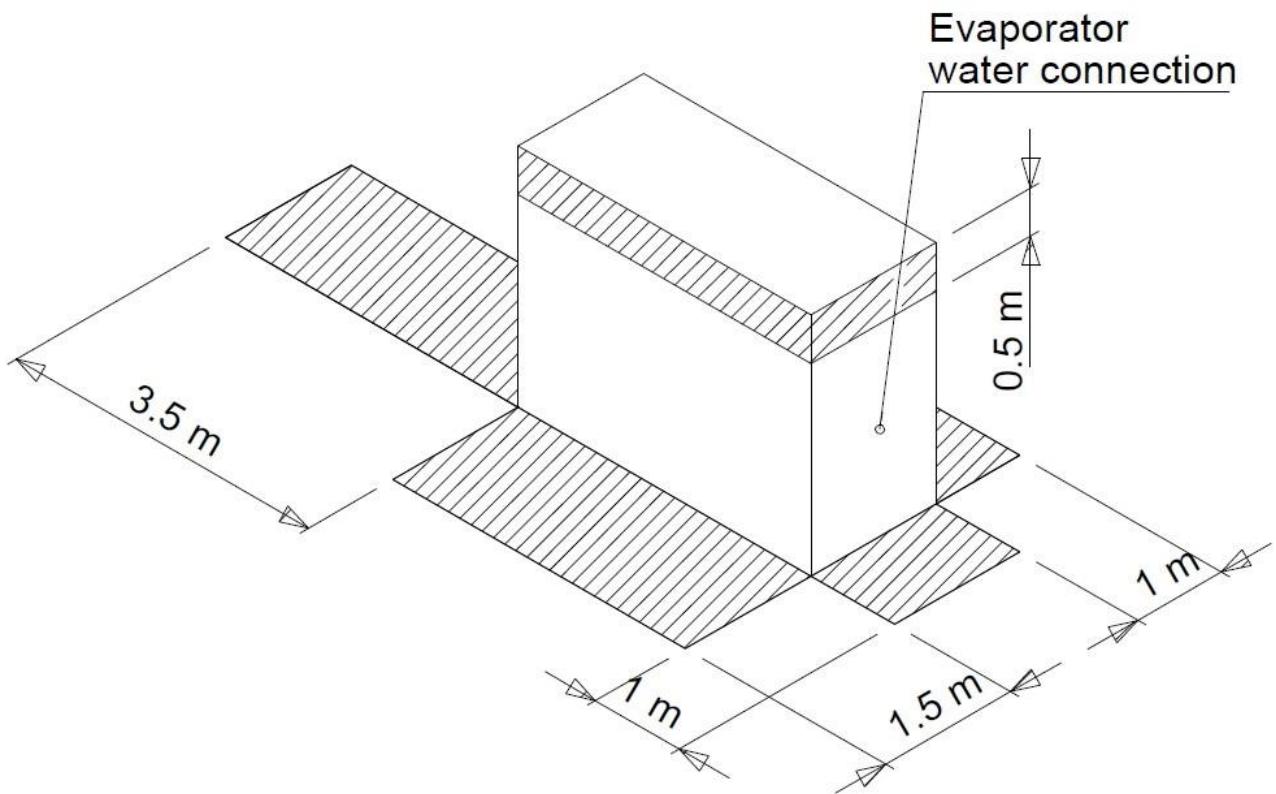

Acoustic protection When noise level must meet special requirements, it is necessary to pay the maximum attention to ensure the perfect insulation of the unit from the support base by applying appropriate anti-vibration devices on the unit, on the water pipes and on the electrical connections.

Storage The environment conditions have to be in the following limits:

- Maximum ambient temperature 50°C
- Minimum ambient temperature: - 20°C
- Maximum relative humidity: 95% not condensing

Storage below the minimum temperature may cause damage to components. Storage above the maximum temperature causes opening of safety valves. Storage in condensing atmosphere may damage electronic components

Technical Specifications

General The chiller will be designed and manufactured in accordance with the following European directives:

- Construction of pressure vessel 2014/68/EU
- Machinery Directive 2006/42/EC
- Low Voltage 2014/35/EU
- Electromagnetic Compatibility 2014/30/EU
- Electrical & Safety codes EN60204-1/EN61439-1/EN61439-2
- Manufacturing & Quality Standards UNI EN ISO 9001:2008
- Environmental Management System UNI EN ISO 14001:2004
- Health & Safety Management System BS OHSAS 18001:2007

To avoid any losses, the unit will be tested at full load in the factory (at the nominal working conditions and water temperatures). The chiller will be delivered to the job site completely assembled and charged with refrigerant and oil. The installation of the chiller must comply with the manufacturer's instructions for rigging and handling equipment.

The unit will be able to start up and operate (as standard) at full load with:

- evaporator leaving fluid temperature between °C and °C
- condenser leaving fluid temperature between °C and °C

Refrigerant Only HFO R1234ze can be used.

Performance Chiller shall supply the following performances:

- Number of chiller(s): unit(s)
- Cooling capacity for single chiller: kW
- Power input for single chiller in cooling mode: kW
- Evaporator heat exchanger entering water temperature in cooling mode: °C
- Evaporator heat exchanger leaving water temperature in cooling mode: °C
- Evaporator heat exchanger water flow: l/s
- Condenser heat exchanger entering water temperature in cooling mode: °C
- Condenser heat exchanger leaving water temperature in cooling mode: °C
- Condenser heat exchanger water flow: l/s

Operating voltage range should be 400V ±10%, 3ph, 50Hz , voltage unbalance maximum 3%, without neutral conductor and shall only have one power connection point.

Unit description Sound level and vibrations Sound pressure level at 1 meter distance in free field, semispherical conditions, shall not exceeddB(A). The sound pressure levels must be rated in accordance to ISO 3744. Vibration on the base frame should not exceed 2 mm/s.

Dimensions Unit dimensions shall not exceed following indications: Unit length mm

Unit width mm

Unit height mm

Compressors The unit shall be equipped with:

- Semi-hermetic, single-screw type with one main helical rotor and two gate rotors. The gate rotors will be constructed of a carbon impregnated engineered composite material. The gate rotor supports will be constructed of cast iron.
- Compressor's rotational speed shall be continuously adjusted by means of inverter (stepless regulation) allowing accurate water temperature control and efficient capacity modulation.
- Compressor shall be able to adapt the discharge pressure of the refrigerant to any operating conditions by means of variable volume ratio system.
- Refrigerant system differential pressure shall provide oil injection on all moving compressor parts to correctly lubricate them. Electrical oil pump lubricating system is not acceptable.

- The compressor's oil cooling must be realized, when necessary, by refrigerant liquid injection. External oil cooling system will not be accepted.
- The oil separator shall be integrated within the condenser and shall not require oil pump
- The compressor shall be direct driven type, without gear transmission between the screw and the electrical motor.
- Compressor shall be equipped with two thermal protections realized by means of thermistors for high temperature protection: one temperature sensor to protect electrical motor and another sensor to protect unit and lubricating oil from high discharge gas temperature.
- No any oil-crankcase heater will be accepted on the unit.
- Compressor shall be fully field serviceable.

Evaporator The units shall be equipped with a flooded shell & tube evaporator with water flowing inside the tubes and refrigerant boiling outside. The tubes are enhanced for maximum heat transfer and rolled into steel tube sheet and sealed. The tubes are individually replaceable.

- The external shell shall be insulated with flexible, closed cell polyurethane insulation material (20-mm thick).
- The water connections shall be VICTAULIC type connections as standard to ensure quick mechanical disconnection between the unit and the hydronic network.
- The evaporator will be manufactured in accordance to PED standard (2014/68/EU).
- The water side shall be designed for 10 bar of maximum operating pressure; vents and drain shall be provided.

Condenser The unit shall be equipped with single-pass counter-flow shell & tube heat exchanger with water flowing inside the tubes and refrigerant condensing outside. The lower side of the condenser shall be provided with subcooling section for improved unit performances. The tubes shall be enhanced for maximum heat transfer and rolled into steel tube sheet and sealed. The tubes shall be individually replaceable.

- The water connections shall be VICTAULIC type connections as standard to ensure quick mechanical disconnection between the unit and the hydronic network.
- The condenser will be manufactured in accordance to PED standard (2014/68/EU).
- The water side shall be designed for 10 bar of maximum operating pressure; vents and drain shall be provided.
- The oil separating section shall be integrated within the condenser.

Refrigerant circuit The unit shall have one independent refrigerant circuit and one variable frequency driver per compressor (Inverter).

The circuit shall include as standard: electronic expansion device piloted by unit's microprocessor control, compressor discharge shut-off valve, liquid line shut-off valve, sight glass with moisture indicator, replaceable filter drier, charging valves, high pressure switch, high and low pressure transducers, oil pressure transducer and insulated suction line.

Condensation control The compressor automatically unloads when high condensing pressure is detected. This to prevent the shutdown of the refrigerant circuit (shutdown of the unit) due to a high-pressure fault.

Low sound unit configurations (on request) The chiller shall be provided with an acoustical compressor enclosure. This enclosure shall be realized with a light, corrosion resistant aluminum structure and metal panels. The compressor sound-proof enclosure shall be internally fitted with flexible, multi-layer, high density materials.

Electrical control panel Power and control shall be located in the main panel that will be manufactured to ensure protection against all weather conditions.

- The electrical panel shall be IP54 and (with the doors opened) internally protected against possible accidental contact with electrical components (IP20).
- The main panel shall be fitted with a main switch interlocked door.
- The power section will include compressors protection devices, compressors starters and control circuit power supply.

Controller The controller will be installed as standard and it will be used to modify unit set-points and check control parameters.

A display installed on the outside of the control panel's door will allow easy access to chiller operating status including water temperatures and refrigerant pressures and temperatures.

A sophisticated software with predictive logic will select the most energy efficient combination of compressor load and electronic expansion valve position keeping stable operating conditions and maximizing chiller efficiency and reliability.

In addition to normal operating functionalities, unit controller will take corrective actions in case the chiller operating outside recommended working conditions.

Unit controller shall be able to protect critical unit components thanks to the signals received by the various unit sensors (such as motor temperature sensors, refrigerant and oil pressure/temperature sensors, pressure switches.....etc..).

Controller main features - Controller shall guarantee following minimum functions:

- Optimized management of compressors stepless capacity control through inverter drive.
- Display of evaporator entering/leaving water temperatures.
- Display of condenser entering/leaving water temperatures.
- Display of refrigerant condensing/evaporating temperatures and pressures.
- Regulation of leaving evaporator water (cooling mode) or condenser water (heating mode). Temp. tolerance $\pm 0,1^{\circ}\text{C}$.
- Display of compressor working hours and number of compressor starts.
- Re-start in case of power failure (automatic or manual depending on failure type).
- Soft load (optimized management of the compressor load during the start-up).
- Set point reset.
- Master/Slave operation (up to 4 chillers connected).

Controller shall guarantee following minimum alarms signaling:

- Phase loss.
- Evaporator water flow loss.
- Evaporator water freezing protection.
- External alarm.
- Low evaporator refrigerant pressure.
- High refrigerant pressure (transducer).
- High refrigerant pressure (switch).
- Low pressure ratio.
- High refrigerant discharge temperature.
- High oil pressure differential.
- High motor temperature.

High Level Communications Interface (on request) - The chiller shall be able to communicate to BMS (Building Management System) based on the most common protocols such as:

- ModbusRTU
- LonWorks
- BacNet BTP certified over IP and MS/TP (class 4) (Native)
- Ethernet TCP/IP.

Master/Slave - the unit shall be able to operate in Master / Slave mode in order to be connected with other similar unit (up to 4). The master unit shall manage the slave units connected in series on the hydraulic plant with the aim of optimize the running hours of each compressor.

For more information email info@daikinapplied.uk or visit www.daikinapplied.uk

For all Daikin Applied UK,
Daikin Applied Service &
Spares enquiries call us on:
0345 565 2700



Daikin Europe N.V. participates in the Eurovent Certified Performance programme for Liquid Chilling Packages and Hydronic Heat Pumps, Fan Coil Units and Variable Refrigerant Flow systems. Check ongoing validity of certificate:
www.eurovent-certification.com

The present publication is drawn up by way of information only and does not constitute an offer binding upon Daikin Europe N.V. Daikin Europe N.V. has compiled the content of this publication to the best of its knowledge. No express or implied warranty is given for the completeness, accuracy, reliability or fitness for particular purpose of its content and the products and services presented therein. Specifications are subject to change without prior notice. Daikin Europe N.V. explicitly rejects any liability for any direct or indirect damage, in the broadest sense, arising from or related to the use and/or interpretation of this publication. All content is copyrighted by Daikin Europe N.V.

