

EWAD TZ-B

Air cooled chiller
with inverter screw
compressor

Product manual

Nominal capacity range 170 - 1100 kW
3 efficiency levels / 3 sound configuration
Best performances at full load and part load
Design for commercial and industrial applications
Operation at full load up to 55°C

Refrigerant: R-134a
Performance according to EN14511

Code	CSS
Date	November 2018
EWAD	R3.7.2

Table of content

EWAD TZ-B

Features and benefits		2	Sound levels	64
General characteristics		5	Silver series	
Nomenclature		10	EWAD TZ SS B	64
Options			EWAD TZ SL B	65
Standard options		11	EWAD TZ SR B	66
Mechanical options		13	Gold Series	
Electrical options		15	EWAD TZ XS B	67
Installation options		18	EWAD TZ XL B	68
			EWAD TZ XR B	69
Technical specifications performance data		19	Platinum series	
Silver series			EWAD TZ PS B	70
EWAD TZ SS B		19	EWAD TZ PL B	71
EWAD TZ SL B		22	EWAD TZ PR B	72
EWAD TZ SR B		25		
Gold Series			Operating limits	73
EWAD TZ XS B		28	Operating envelope	73
EWAD TZ XL B		31	Minimum water flow	79
EWAD TZ XR B		34	Water quality	83
Platinum series			Pump curves (technical data)	84
EWAD TZ PS B		37	Single pump low lift	
EWAD TZ PL B		40	Silver series	84
EWAD TZ PR B		43	Gold series	86
			Platinum series	88
Electrical specifications		46	Single pump high lift	
Silver series			Silver series	90
EWAD TZ SS B		46	Gold series	92
EWAD TZ SL B		48	Platinum series	94
EWAD TZ SR B		50	Double pump low lift	
Gold Series			Silver series	96
EWAD TZ XS B		52	Gold series	98
EWAD TZ XL B		54	Platinum series	100
EWAD TZ XR B		56	Double pump high lift	
Platinum series			Silver series	102
EWAD TZ PS B		58	Gold series	104
EWAD TZ PL B		60	Platinum series	106
EWAD TZ PR B		62		
			Hydraulic scheme	109
			Dimensional drawings	112
			Installation notes	121
			Technical specification	123

Low operating cost Flexibility and Reliability The EWAD-TZ B chiller range is the result of careful design, aimed to optimize the energy efficiency of the chillers, with the objective of bringing down operating costs, effectiveness and economical management. The chillers feature high efficiency single screw Inverter driven compressor design, optimized condensing section, advanced technology condenser fans and a "shell & tube" or plate heat exchanger evaporator with low refrigerant pressure drops.

The EWAD-TZ B range came with 3 efficiency level

- **EWAD~TZ B S- "SILVER": avg. EER 2,9 avg. ESEER 4,5**
- **EWAD~TZ B X- "GOLD": avg. EER 3,2 avg. ESEER 5,1**
- **EWAD~TZ B P- "PLATINUM": avg. EER 3,5 avg. ESEER 5,5**

and 3 sound levels:

- **Standard sound**

- **Low sound:** the sound attenuation is achieved thanks to special connections at the suction of each compressor that allows to reduce drastically the vibration transmission.

- **Reduced sound:** the compressors are closed into a soundproof cabinet especially designed to minimize the sound emissions. Also special connections at the suction of each compressor allows to reduce drastically the vibration transmission.

An extensive list among of mechanical, electrical, control and installation related options are available



Combining all together, **more than 500 combinations are available.**

Low operating sound levels Very low sound levels both at full load and part load conditions are achieved by the latest compressor design and by a unique new fan that moves large volume of air at exceptionally low sound levels and by the virtually vibration-free operation.

Outstanding reliability The chillers have one or two truly independent refrigerant circuits, in order to assure maximum safety for any maintenance, whether planned or not. They are equipped with a rugged compressor design with advanced composite compressor gaterotors material, a proactive control logic and are full factory-run-tested to optimized trouble-free operation.

Infinite capacity control Cooling capacity control is infinitely variable by means of a Inverter driven screw compressor controlled by microprocessor system. Each unit has infinitely variable capacity control from 100% down to minimum capacity which is variable depending on unit model. This modulation allows the compressor capacity to exactly match the building cooling load without any leaving evaporator water temperature fluctuation. This chilled water temperature fluctuation is avoided only with a stepless control.

Inverter stepless regulation plus variable volume ratio control Based on the geographical location and the application, the outside temperature and the load profile of a building can vary enormously but our system has an infinitely variable load regulation and working conditions without pre-set steps for a perfect comfort solution. The inverter stepless regulation plus variable volume ratio control provides the required capacity to meet the demand, ensuring highly accurate leaving water temperature control and so delivering optimal comfort with the best performances possible at every condition.

Superior control logic The MicroTech III controller provides an easy to use control environmental. The control logic is designed to provide maximum efficiency, to continue operation in unusual operating conditions and to provide a history of unit operation. One of the greatest benefits is the easy interface with LonWorks, Bacnet, Ethernet TCP/IP or Modbus communications. Master/Slave operation is provided as standard allowing to connect up to 4 units working as a single bigger chiller.

Dynamic Condensing Pressure Management A new superior software logic has been developed to get the highest efficiency at whichever operating condition: thanks to the Dynamic Condensing Pressure Management the chiller controller adjusts the condensing pressure set-point to minimize the overall chiller power input.

High full load and part load efficiency

High efficiency at full load, but especially maximum efficiency at part load conditions - which is the majority of the operating time of a chiller - are the factors that allow considerable savings in a system's annual energy costs.

Comparing the performance of the EWAD~TZB (VFD technology Variable Volume Ratio) with the traditional fix-speed chiller without Variable Volume Ratio, the performance difference, in favor of the VFD technology, increases as the load decrease and becomes maximum in correspondence of the conditions that have the highest frequency of occurrence.

thanks to Inverter and Variable Volume Ratio technology EWAD~TZ B performances are always better than the standard technology without VFD.

The difference on performances increases at part load which is the condition that happen for the most of the time.

The high performances of EWAD~TZ B ensure short Return Of Investment versus standard technology

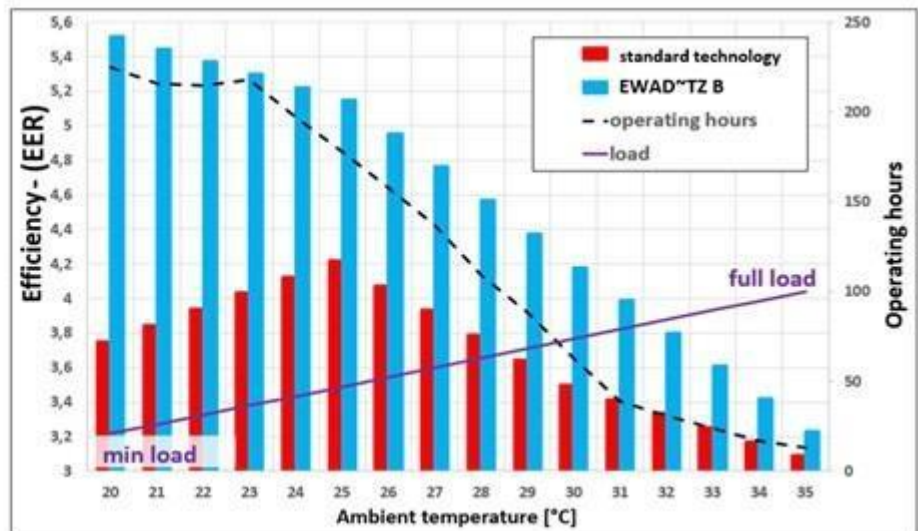

Note the operating hours for each temperature refers to EN14825 bin table.

Quick comfort conditions The ability to vary the output power in direct relation to the cooling requirements of the system, allow the possibility to achieve building comfort conditions much faster at start-up.

Seasonal quietness Very low sound levels in part load conditions are achieved by varying the fans speed, but especially thanks to the variation of compressor frequency, which ensure the minimum sound level at all the time.

No starting current No current spikes at start-up. The starting current is always lower than current absorbed in the maximum operating conditions (FLA).

Displacement power factor always > 0.95 The EWAD~TZ B range can operate always with a displacement power factor > 0.95, which allows building owners to avoid power factor penalties and decrease electrical losses in cable and transformers.

Code requirements – Safety and observant of laws/directives Units are designed and manufactured in accordance with applicable selections of the following:

Construction of pressure vessel	2014/68/EU
Machinery Directive	2006/42/EU
Low Voltage	2014/35/EU
Electromagnetic Compatibility	2014/30/EU
Electrical & Safety codes	EN 60204-1 / EN 60335-2-40
Manufacturing & Quality Standards	UNI EN ISO 1400

Certifications Units are CE marked, complying with European directives in force, concerning manufacturing and safety. On request units can be produced complying with laws in force in non European countries (ASME, GOST, etc.), and with other applications, such as naval (RINA, etc.).

Additional information related to F-GAS Regulation (EU) No 517/2014 of the European Parliament and of the Council of 16 April 2014 on fluorinated greenhouse gases and repealing Regulation (EC) No 842/2006

Unit model			Refrigerant type	Refrigerant GWP	No. of circuits	Refrigerant charge circuit 1 (kg)	Refrigerant charge circuit 1 (TCO2Eq)	Refrigerant charge circuit 2 (kg)	Refrigerant charge circuit 2 (TCO2Eq)	
SILVER	EWAD160TZSSB1	EWAD160TZSLB1	EWAD160TZSRB1	R134a	1430	1	27	39	-	-
	EWAD190TZSSB1	EWAD190TZSLB1	EWAD190TZSRB1	R134a	1430	1	29	41	-	-
	EWAD240TZSSB1	EWAD240TZSLB1	EWAD240TZSRB1	R134a	1430	1	33	47	-	-
	EWAD270TZSSB1	EWAD270TZSLB1	EWAD270TZSRB1	R134a	1430	1	38	54	-	-
	EWAD300TZSSB1	EWAD300TZSLB1	EWAD300TZSRB1	R134a	1430	1	41	59	-	-
	EWAD360TZSSB1	EWAD360TZSLB1	EWAD360TZSRB1	R134a	1430	1	52	74	-	-
	EWAD380TZSSB2	EWAD380TZSLB2	EWAD380TZSRB2	R134a	1430	2	29	41	29	41
	EWAD450TZSSB2	EWAD450TZSLB2	EWAD450TZSRB2	R134a	1430	2	30	42	30	42
	EWAD495TZSSB2	EWAD495TZSLB2	EWAD495TZSRB2	R134a	1430	2	34	49	34	49
	EWAD570TZSSB2	EWAD570TZSLB2	EWAD570TZSRB2	R134a	1430	2	38	54	38	54
	EWAD610TZSSB2	EWAD610TZSLB2	EWAD610TZSRB2	R134a	1430	2	39	55	39	55
	EWAD660TZSSB2	EWAD660TZSLB2	EWAD660TZSRB2	R134a	1430	2	42	59	42	59
	EWAD700TZSSB2	EWAD700TZSLB2	EWAD700TZSRB2	R134a	1430	2	45	64	45	64
	EWAD820TZSSB2	EWAD820TZSLB2	EWAD820TZSRB2	R134a	1430	2	55	79	55	79
	EWAD900TZSSB2	EWAD900TZSLB2	EWAD900TZSRB2	R134a	1430	2	55	79	55	79
	EWAD990TZSSB2	EWAD990TZSLB2	EWAD990TZSRB2	R134a	1430	2	63	90	63	90
	EWADC10TZSSB2	EWADC10TZSLB2	EWADC10TZSRB2	R134a	1430	2	71	101	71	101
EWADC11TZSSB2	EWADC11TZSLB2	EWADC11TZSRB2	R134a	1430	2	79	113	79	113	

Unit model			Refrigerant type	Refrigerant GWP	No. of circuits	Refrigerant charge circuit 1 (kg)	Refrigerant charge circuit 1 (TCO2Eq)	Refrigerant charge circuit 2 (kg)	Refrigerant charge circuit 2 (TCO2Eq)	
GOLD	EWAD190TZXS1	EWAD190TZXL1	EWAD190TZXR1	R134a	1430	1	36	51	-	-
	EWAD220TZXS1	EWAD220TZXL1	EWAD220TZXR1	R134a	1430	1	39	56	-	-
	EWAD240TZXS1	EWAD240TZXL1	EWAD240TZXR1	R134a	1430	1	40	57	-	-
	EWAD290TZXS1	EWAD290TZXL1	EWAD290TZXR1	R134a	1430	1	51	73	-	-
	EWAD320TZXS1	EWAD320TZXL1	EWAD320TZXR1	R134a	1430	1	51	73	-	-
	EWAD360TZXS2	EWAD360TZXL2	EWAD360TZXR2	R134a	1430	2	32	46	32	46
	EWAD420TZXS2	EWAD420TZXL2	EWAD420TZXR2	R134a	1430	2	32	46	32	46
	EWAD440TZXS2	EWAD440TZXL2	EWAD440TZXR2	R134a	1430	2	33	46	33	46
	EWAD450TZXS2	EWAD450TZXL2	EWAD450TZXR2	R134a	1430	2	37	53	37	53
	EWAD540TZXS2	EWAD540TZXL2	EWAD540TZXR2	R134a	1430	2	40	57	40	57
	EWAD570TZXS2	EWAD570TZXL2	EWAD570TZXR2	R134a	1430	2	40	57	40	57
	EWAD610TZXS2	EWAD610TZXL2	EWAD610TZXR2	R134a	1430	2	45	64	45	64
	EWAD660TZXS2	EWAD660TZXL2	EWAD660TZXR2	R134a	1430	2	48	69	48	69
	EWAD680TZXS2	EWAD680TZXL2	EWAD680TZXR2	R134a	1430	2	48	69	48	69
	EWAD770TZXS2	EWAD770TZXL2	EWAD770TZXR2	R134a	1430	2	63	90	63	90
	EWAD850TZXS2	EWAD850TZXL2	EWAD850TZXR2	R134a	1430	2	63	90	63	90
	EWAD910TZXS2	EWAD910TZXL2	EWAD910TZXR2	R134a	1430	2	71	101	71	101
EWADC10TZXS2	EWADC10TZXL2	EWADC10TZXR2	R134a	1430	2	79	113	79	113	
EWADC11TZXS2	EWADC11TZXL2	EWADC11TZXR2	R134a	1430	2	79	113	79	113	

Unit model			Refrigerant type	Refrigerant GWP	No. of circuits	Refrigerant charge circuit 1 (kg)	Refrigerant charge circuit 1 (TCO2Eq)	Refrigerant charge circuit 2 (kg)	Refrigerant charge circuit 2 (TCO2Eq)	
PLATINUM	EWAD190TZPS1	EWAD190TZPL1	EWAD190TZPR1	R134a	1430	1	49	70	-	-
	EWAD220TZPS1	EWAD220TZPL1	EWAD220TZPR1	R134a	1430	1	49	70	-	-
	EWAD240TZPS1	EWAD240TZPL1	EWAD240TZPR1	R134a	1430	1	50	72	-	-
	EWAD290TZPS1	EWAD290TZPL1	EWAD290TZPR1	R134a	1430	1	51	73	-	-
	EWAD300TZPS1	EWAD300TZPL1	EWAD300TZPR1	R134a	1430	1	58	83	-	-
	EWAD350TZPS2	EWAD350TZPL2	EWAD350TZPR2	R134a	1430	2	39	55	39	55
	EWAD420TZPS2	EWAD420TZPL2	EWAD420TZPR2	R134a	1430	2	43	61	43	61
	EWAD495TZPS2	EWAD495TZPL2	EWAD495TZPR2	R134a	1430	2	47	67	47	67
	EWAD550TZPS2	EWAD550TZPL2	EWAD550TZPR2	R134a	1430	2	53	76	53	76
	EWAD620TZPS2	EWAD620TZPL2	EWAD620TZPR2	R134a	1430	2	57	82	57	82
	EWAD720TZPS2	EWAD720TZPL2	EWAD720TZPR2	R134a	1430	2	79	113	79	113
	EWAD820TZPS2	EWAD820TZPL2	EWAD820TZPR2	R134a	1430	2	87	124	87	124
	EWAD950TZPS2	EWAD950TZPL2	EWAD950TZPR2	R134a	1430	2	94	135	94	135

Note: Equipment contains fluorinated greenhouse gases. Actual refrigerant charge depends on the final unit construction, details can be found on the unit labels.

Single screw compressor with integrated Inverter and Variable Volume Ratio technology

The EWAD~TZ B is equipped with the latest technology of screw single compressors. Thanks to the careful design, result of years of experience, the single screw compressors by DAIKIN are characterized by highly balanced load resulting in reduced stress for the components extending the useful life and improving reliability. Vibration and sound emission are also reduced. The high volumetric efficiency of single screw compressors makes them an ideal solution for variable speed applications. Thanks to the Variable Frequency Drive (VFD) technology the EWAD~TZ B is able to match the actual load required from the plant in every circumstances continuously modulating the speed of the compressor's motor, which is the most efficient way to perform the capacity control of the compressor.

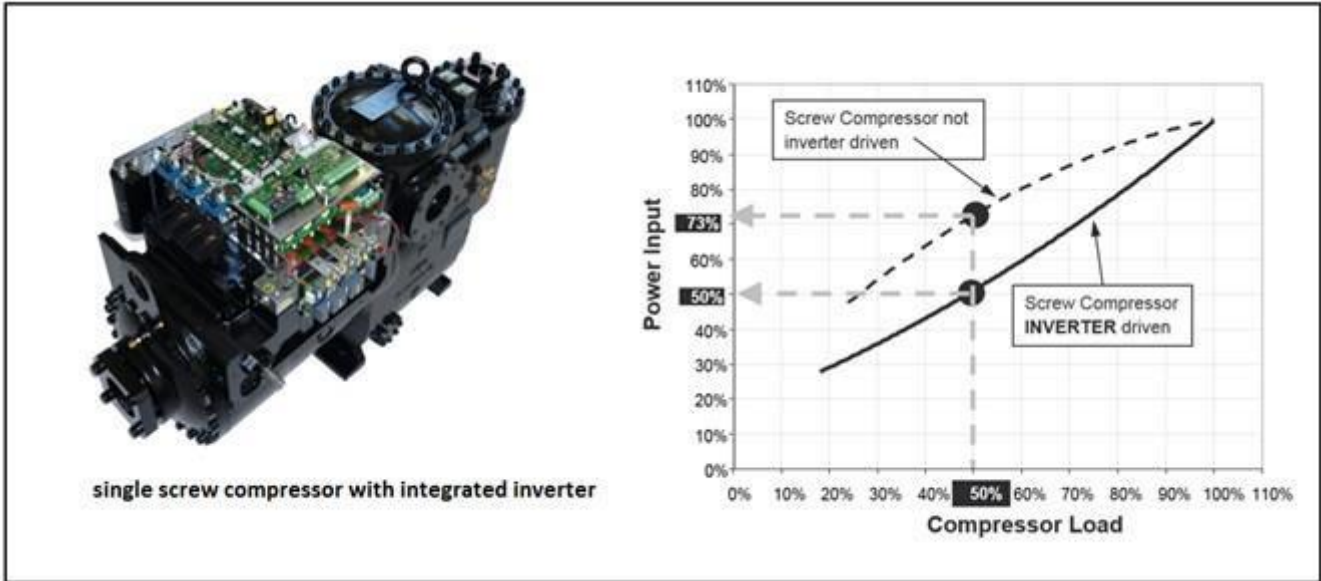

The VFD provides lower starting current compared to typical starters such that the inrush current does not exceed the full load operating current. This feature can help to reduce electrical installation costs, and allows to meet eventual local requirements on maximum possible inrush current.

The VFD drive is installed directly on the compressor and contained in a specifically designed sealed housing. The temperature of the electronic circuit is kept constant thanks to the refrigerant cooling system resulting in:

- more compact electrical panel
- extended life
- improved reliability

The compressors for Gold and Platinum series of EWAD~TZ B are equipped with the new brushless DC motors. This motors are characterized by even higher efficiency and improved reliability.

Variable Volume Ratio Technology

Screw compressors increases the refrigerant pressure by forcing it into a progressive smaller volume, from the suction to the discharge port. Once that the geometry of the compressor is defined the volume ratio of the compressor is also defined. The pressure ratio and the Volume ratio are defined as follow and linked through the equation of state of the gas.

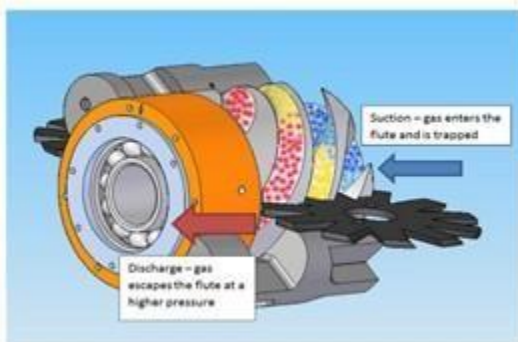

$$\text{Volume Ratio} = \frac{\text{volume of gas at the inlet (suction) of the compressor}}{\text{volume of gas at the outlet (discharge) of the compressor}}$$

$$\text{Pressure ratio} = \frac{\text{pressure of gas at the outlet (discharge) of the compressor}}{\text{pressure of gas at the inlet (suction) of the compressor}}$$

$$\text{Pressure ratio} = (\text{Volume Ratio})^k$$

k is a coefficient characteristic of the refrigerant

As result the geometry of the compressor define the characteristic pressure ratio. On the market are available compressors optimized for different pressure ratios to be used according to the application. A compressor optimized for low compression ratio will not be efficient in operations with high compression ratio and vice versa.

During chiller operation the working parameters (condensing and evaporating pressure) are subjected to sensible changes, due to the variations of the ambient temperature and energy demand from the plant, leading to a variable pressure ratio (defined as condensing pressure on evaporating pressure).

An air cooled chiller equipped with a compressor characterized by high volume ratio will have good performances at full load with high ambient temperatures, while in case of moderate ambient temperatures and during part load operation, the actual pressure ratio for the chiller will be lower the compressor's characteristic. In this situation the refrigerant will result more compressed than the actual needs. This lead to a phenomenon named "over-compression". The "extra-work" of the compressor result in an unnecessary waste of energy.

On the other and, a chiller equipped with a compressor characterized by low volume ratio will have good performance during part load operation and low ambient temperature, but it will be less efficient during full load operation and with high ambient temperature.

In this case the actual pressure ratio for the chiller will be higher the compressor's characteristic, so at the discharge of the compressor the gas will be at a lower pressure than the condensing pressure. Part of the refrigerant will go from the condenser back to the compressor and the compressor will spend additional work to re-send it to the condenser. This phenomenon is known as "under-compression"

In order to obtain the best efficiency possible at every working condition Daikin compressors can adjust their own geometry according to the real operating conditions enhancing the efficiency. This is possible thanks to a moving slide delay the discharge of the compression according to the actual operating conditions.

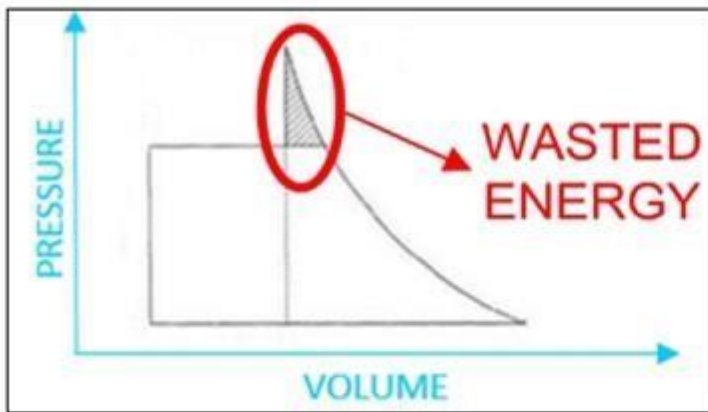

Over-Compression

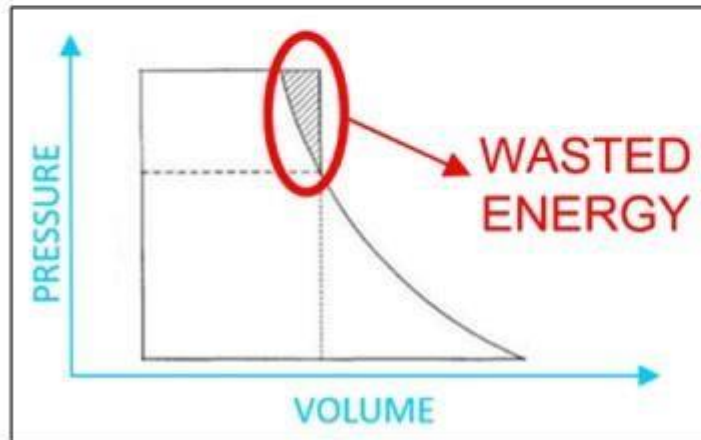
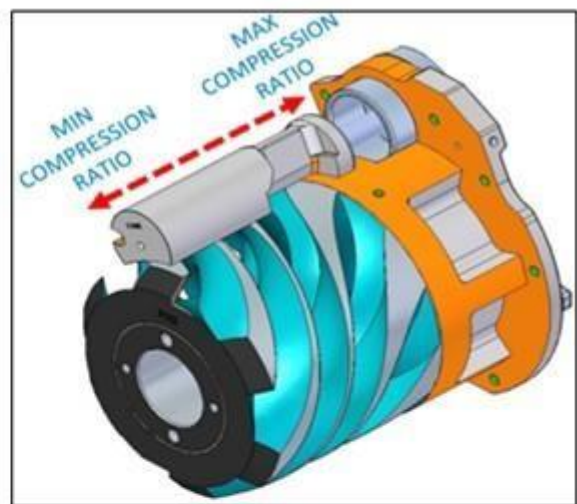

Under-Compression

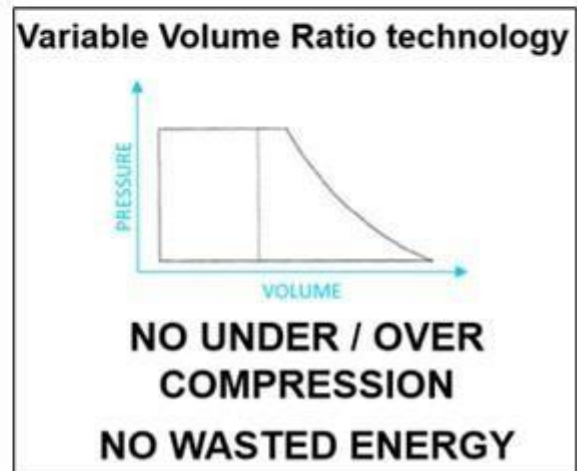

Refrigerant The compressors have been designed to operate with R-134a, ecological refrigerant with zero ODP (Ozone Depletion Potential) and very low GWP (Global Warming Potential), resulting in low TEWI (Total Equivalent Warming Impact).

Evaporator

Single circuit models (Plate Heat Exchanger) The unit is equipped with a direct expansion plate to plate type evaporator. This heat exchanger is made of stainless steel brazed plates and is covered with a 20mm closed cell insulation material. The exchanger is equipped with an electric heater for protection against freezing down to -28°C and evaporator water connections are provided with victaulic kit (as standard). The evaporator has 1 circuit (one compressor) and is manufactured in accordance to 2014/68/EU. Flow switch on evaporator available as option (shipped loose). Water filter is a standard option for single circuit unit.

Note the installation of the filter is mandatory.

Dual circuit models (Shell&Tube) The unit is equipped with a direct expansion Shell&Tube evaporator with refrigerant evaporating inside the tubes and water flowing outside. The tubes are enhanced for maximum heat transfer and rolled into steel tube sheet and sealed.

The evaporators are single-pass on both the refrigerant and water sides for pure counter-flow heat exchange and low refrigerant pressure drops. Both characteristics contribute to the heat exchanger effectiveness and total unit's outstanding efficiency. The water side is designed for 10 bar of maximum operating pressure and is provided with vents and drain.

The external shell is covered with a 10mm closed cell insulation material and the evaporator water connections are provided with victaulic kit (as standard). Each evaporator has 2 circuits, one for each compressor and is manufactured in accordance to 2014/68/EU. Flow switch on evaporator available as option (shipped loose). Water filter is not available as option from the factory.

Note the installation of the filter is mandatory.

Condenser The condenser is made entirely of aluminum with flat tubes containing small channels. Full-depth louvered aluminum fins are inserted between the tubes maximizing the heat exchange. The Microchannel technology ensures the highest performance with the minimum surface for the exchanger. The quantity of refrigerant is also reduced compared to Cu/Al condenser.

Special treatment ensure resistance to the corrosion by atmospheric agents extending the life time.

Note: for application in industrial, costal high polluted urban environment or combinations of the above a proper evaluation is needed to understand if, according to the specific environment, additional protections measures are needed.

Condenser fans

SILVER: The ON/OFF condenser fans are propeller type with high efficiency design blades to maximize performances. The material of the blades is glass reinforced resin and each fan is protected by a guard. Fan motors are protected by circuit breakers installed inside the electrical panel as a standard. The motors are IP54 and are suitable for use with inverters (available as option). The motors are IP54.

GOLD: The Inverter Driven (AC inverter type) condenser fans are propeller type with high efficiency design blades to maximize performances. The material of the blades is glass reinforced resin and each fan is protected by a guard. Fan motors are protected by circuit breakers installed inside the electrical panel as a standard. The motors are IP54.

PLATINUM: The condenser fans are "brushless" (EC) type and are made with synchronous motors excited by permanent magnets and with phase currents controlled by a PWM inverter integrated in the fan motor housing, that allows operation at different speeds. With this technology the fans reach high efficiencies with an extremely low noise level across a very wide speed range. The motors are IP54.

Electronic expansion valve The unit is equipped with the most advanced electronic expansion valves to achieve precise control of refrigerant mass flow. As today's system requires improved energy efficiency, tighter temperature control, wider range of operating conditions and incorporate features like remote monitoring and diagnostics, the application of electronic expansion valves becomes mandatory.

Electronic expansion valves possess unique features: short opening and closing time, high resolution, positive shut-off function to eliminate use of additional solenoid valve, continuous modulation of mass flow without stress in the refrigerant circuit and corrosion resistance stainless steel body.

Electronic expansion valves are typically working with lower ΔP between high and low pressure side, than a thermostatic expansion valve. The electronic expansion valve allows the system to work with low condenser pressure (winter time) without any refrigerant flow problems and with a perfect chilled water leaving temperature control.

Refrigerant circuit

Each unit has one or two independent refrigerant circuits and each one includes:

- Compressor Inverter driven with integrated oil separator
- Refrigerant
- Evaporator
- Air Cooled Condenser
- Electronic expansion valve
- Discharge line shut off valve
- Liquid line shut off valve
- Sight glass with moisture indicator
- Filter drier
- Economizer circuit with electronic expansion valve
- Charging valves
- High pressure switch
- High pressure transducers
- Low pressure transducers
- Oil pressure transducer
- Suction temperature sensor

Electrical control panel Power and control are located in the main panel that is manufactured to ensure protection against all weather conditions. The electrical panel is IP54 and (when opening the doors) internally protected against possible accidental contact with live parts. The main panel is fitted with a main switch interlocked door that shuts off power supply when opening.

Power Section The power section includes compressors and fans protection devices, fans starters and control circuit power supply.

MicroTech III controller MicroTech III controller is installed as standard; it can be used to modify unit set-points and check control parameters. A built-in display shows chiller operating status plus temperatures and pressures of water, refrigerant and air, programmable values, set-points. A sophisticated software with predictive logic, selects the most energy efficient combination of compressors, EEXV and condenser fans to keep stable operating conditions to maximize chiller energy efficiency and reliability. MicroTech III is able to protect critical components based on external signals from its system (such as motor temperatures, refrigerant gas and oil pressures, correct phase sequence, pressure switches and evaporator). The input coming from the high pressure switch cuts all digital output from the controller in less than 50ms, this is an additional security for the equipment. Fast program cycle (200ms) for a precise monitoring of the system. Floating point calculations supported for increased accuracy in Pressure / Temperature conversions.

Control section - main features

Main control features are (for more information refer to Unit Control Manual):

- Optimized management of compressors stepless capacity control through inverter drive.
- Display of evaporator entering/leaving water temperatures.
- Display of Ambient Temperature
- Display of refrigerant condensing/evaporating temperatures and pressures.
- Regulation of leaving evaporator water (cooling mode) or condenser water (heating mode).
- Display of compressor working hours and number of compressor starts.
- Re-start in case of power failure (automatic or manual depending on failure type).
- Soft load (optimized management of the compressor load during the start-up).
- Set point reset.
- Master/Slave operation (up to 4 chillers connected).
- Variable Primary Flow Management (available as option)

Alarms signaling (for more information refer to Unit Control Manual):

- Phase loss.
- Evaporator water flow loss.
- Evaporator water freezing protection.
- External alarm.
- Low evaporator refrigerant pressure.
- High refrigerant pressure (transducer).

- High refrigerant pressure (switch).
- Low pressure ratio.
- High refrigerant discharge temperature.
- High oil pressure differential.
- High motor temperature.

System security

The following securities are available.

- Phase monitor.
- Low Ambient temperature lock-out.
- Freeze protection.

Regulation type

Proportional integral derivative regulation on the evaporator leaving water output probe.

MicroTech III

MicroTech III built-in terminal has the following features.

- 164x44 dots liquid crystal display with white back lighting. Supports Unicode fonts for multi-lingual.
- Key-pad consisting of 3 keys.
- Push'n'Roll control for an increased usability.
- Memory to protect the data.
- General faults alarm relays.
- Password access to modify the setting.
- Application security to prevent application tampering or hardware usability with third party applications.
- Service report displaying all running hours and general conditions.
- Alarm history memory to allow an easy fault analysis.

Supervising systems (on request)**MicroTech III remote communication**

MicroTech III is able to communicate to BMS (Building Management System) based on the most common protocols as:

- ModbusRTU (Native)
- LonWorks, now also based on the international 8040 Standard Chiller Profile and LonMark Technology.
- BacNet BTP certified over IP and MS/TP (class 4) (Native).
- Ethernet TCP/IP (Native).

Nomenclature

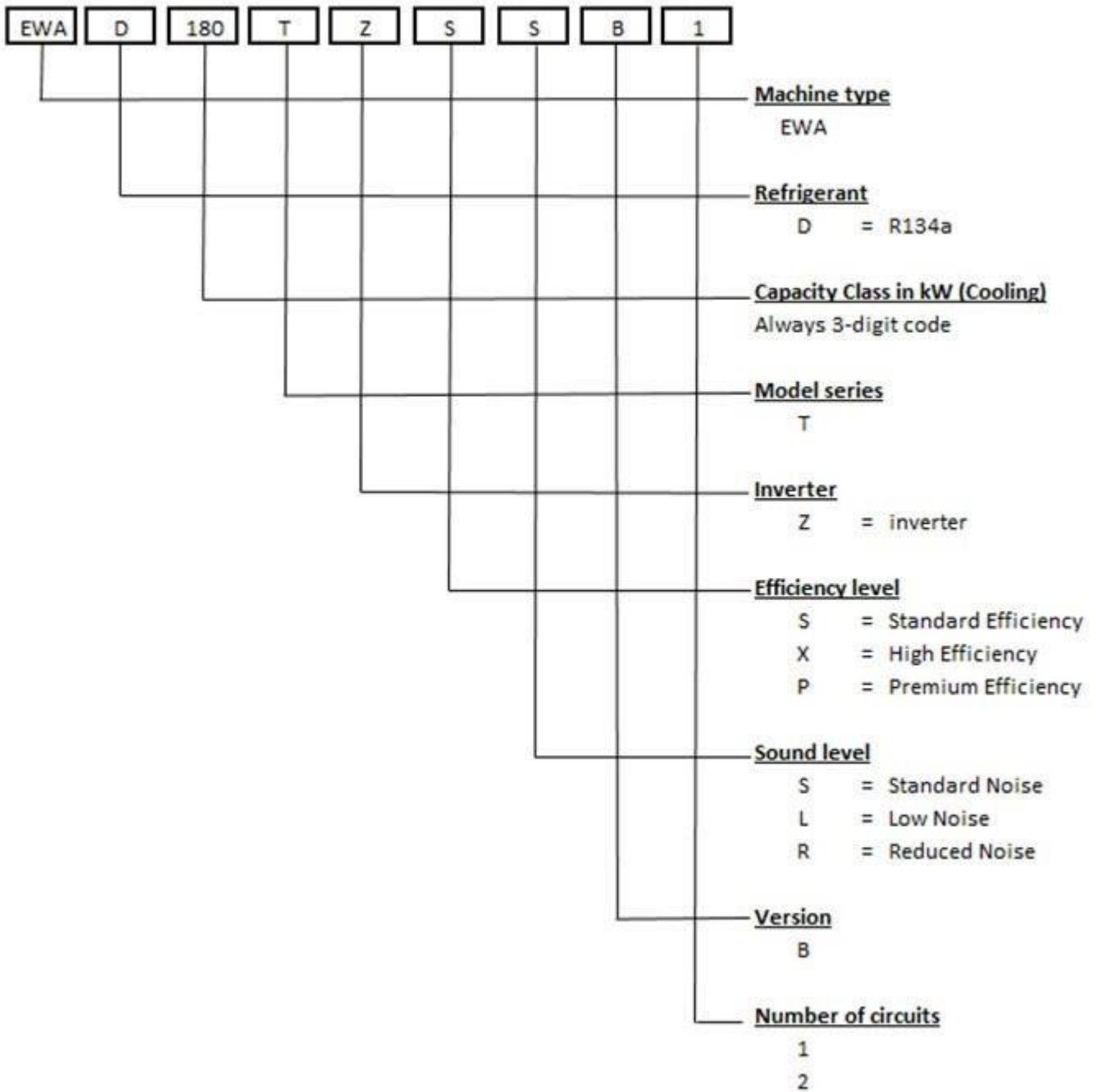

Standard Options (supplied on basic units)

Double set point (opt. code 10 – provided as standard)

Possibility to pre-set two different chilled water temperature set points (cooling mode).

Compressor thermal overload relays (opt. code 11 – provided as standard) – Functionality Included in the compressor inverter device - *Opt. incompatibility 95.*

Phase monitor (opt. code 13 – provided as standard)

Device that monitors input voltage and stops the chiller in case of phase loss or wrong phase sequence.

Inverter compressor starter (opt. code 14 – provided as standard)

Under over voltage control (opt. code 15 – provided as standard)

Electronic device that monitors and displays input voltage, and stops the chiller in case of phase loss, wrong phase sequence, or voltage exceeding minimum and maximum allowed values.

Evaporator Victaulic KIT (opt. code 20 – provided as standard)

For unit equipped with plate to plate heat exchanger the victaulic kit (provided as standard) includes the victaulic joint and the counter pipe fitted with victaulic groove to be welded with the plant pipes - *Opt. incompatibility 21.*

20mm evaporator insulation (opt. code 29 – provided as standard)

The heat exchanger is covered with a 20mm closed cell insulation material - *Opt. incompatibility 08.*

Evaporator electric heater (opt. code 57 – provided as standard)

Electronic expansion valve (opt. code 60 – provided as standard)

Discharge line shut-off valve (opt. code 61– provided as standard)

Installed on the discharge port of the compressor to facilitate maintenance operation.

Suction line shut-off valve (opt. code 62– provided as standard)

Installed on the suction port of the compressor to facilitate maintenance operation.

Set point reset, demand limit and alarm from external device (opt. code 67/90 – provided as standard) Setpoint Reset: The leaving water temperature set-point can be overwritten with an external 4-20mA, through the ambient temperature, or through the evaporator water temperature ΔT . Demand Limit: Chiller capacity can be limited through an external 4-20mA signal or via network. Alarm from external device: The unit controller is able to receive an external alarm signal. The user can decide whether this alarm signal will stop the unit or not.

Hour run meter (opt. code 68 – provided as standard)

General fault contactor (opt. code 69 – provided as standard)

Fans circuit breakers (opt. code 96- provided as standard)

Safety devices that, added to the standard protection devices, protect fan motors against overload and overcurrent.

Main switch interlock door (opt. code 97 – provided as standard)

Master / Slave (opt. code 128 – provided as standard)

The EWAD~TZ B features the new DAIKIN Master/ Slave (M/S) control. Once set which unit has the role of master, the other(s) will operate as slave(s) based on the inputs provided by the master. The chillers must be installed in parallel in the hydronic plant.

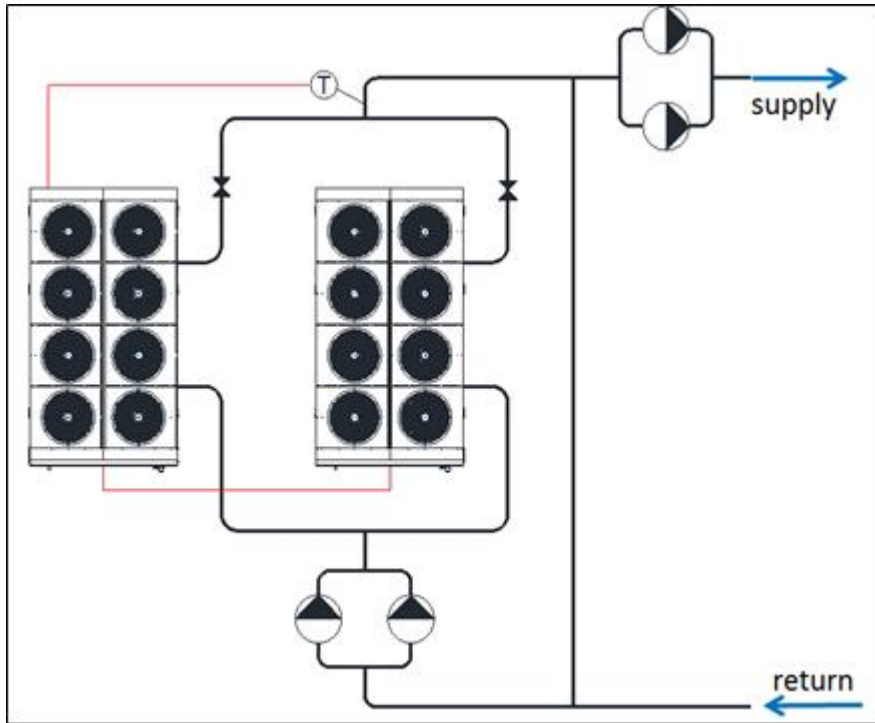

with Master / Slave control is possible to balance the working hours of the compressors enhancing reliability and extending the life of the system

In order to operate in Master/Slave mode an additional probe (PT1000 or NTC10K) must be installed on the common line of the plant and connected to the master unit. The additional probe is not provided by the factory.

Master/Slave can manage units selected with pump on board (fix speed pumps). Note: check valves must be installed at the outlet of each chiller.

Master/Slave can also manage the start and stop of external pumps (not provided by factory). The power supply of external pumps is not provided by the unit.

Water filter (opt. code 115– provided as standard for single circuit unit)

The water filter removes impurities from water by means of a fine physical barrier (available only on single circuit units). It must be installed on the water pipe connected to the heat exchanger inlet.

The filter is shipped loose together with two victaulic joints and two counter pipes to be welded on the plants. Opt. 115 is not available from factory for dual circuit units.

NOTE: The installation of the filter is mandatory.

Mechanical Options – On request

Total Heat Recovery (opt. code 01)

A plate to plate heat exchanger for each refrigerant circuit is installed in series to the air condenser coil. There is no switch nor solenoid valve in the circuit, thus compressor discharged refrigerant is always flowing through the heat recovery exchanger and warm water production is always available while the chiller is providing cooling. During the operation in heat recover the condenser coils provides the sub-cooling ensuring the right amount of liquid at the inlet of the expansion valve. The unit controller manages the condensing temperature set point in order to maximize the cooling effect and amount of energy recovered.

The amount of heat recovered is about the 80/85% (according to the operating conditions) of the total heat rejection of the chiller. The chiller performs the control on the recovery circuit, based on the return water temperature to the unit. Heat recovery capability is subject to cooling load demand (if no cooling demand is present then no heat recovery is available) - *Opt. incompatibility 03.*

Partial Heat Recovery (opt. code 03)

A plate to plate heat exchanger for each refrigerant circuit is installed in series to the air condenser coil. There is no switch nor solenoid valve in the circuit, thus compressor discharged refrigerant is always flowing through the heat recovery exchanger and warm water production is always available while the chiller is providing cooling. During the operation in partial heat recover the super-heated vapor is cooled in the plate heat exchanger than enters in the coil condenser coils provides the sub-cooling ensuring the right amount of liquid at the inlet of the expansion vale. The unit controller does not manage the partial heat recover operation. The recover must

be managed from the plant manager that controls the operation of the pump on the recovery circuit. The amount of heat recovered is about the 15/20% (according to the operating conditions) of the total heat rejection of the chiller. Heat recovery capability is subject to cooling load demand (if no cooling demand is present then no heat recovery is available) - *Opt. incompatibility 01.*

Brine Version (opt. code 08) - *Opt. incompatibility 29-142*

For operation with temperature at the outlet of the evaporator below +4°C the unit must operate with glycol mixture (with ethylene or propylene glycol) and the Brine Version option must be selected.

The Brine version provides different set-up according to the series:

- SILVER

from size 160 to 700: dedicated control function; 6 poles AC fans controlled with inverter. In order to operate with low water temperature the speed of the fans will be increased (from the standard speed of 700 RPM up to 900 RPM) according to the operating conditions; Enhanced insulation.

For size from 820 to C11, the brine option include dedicated control function.

- **GOLD:** Dedicated control function; 6 poles AC fans controlled with inverter. In order to operate with low water temperature the speed of the fans will be increased (from the standard speed of 700 RPM up to 900 RPM) according to the operating conditions; Enhanced insulation.

- **PLATINUM:** Dedicated control; EC fans; Enhanced insulation.

Note: opt. 08 is not compatible with opt. 142 High Ambient kit

Evaporator flange KIT (opt. code 21)

For unit equipped with Shell & Tube exchangers. The flange kit is not available for single circuit units - *Opt. incompatibility 20.*

High pressure side manometers (opt. code 63)

Low pressure side manometers (opt. code 64)

Hydronic kits:

- **One centrifugal pump (Low lift) (opt. code 78)** - *Opt. incompatibility – All the other centrifugal pumps.*
- **One centrifugal pump (high lift) (opt. code 79)** - *Opt. incompatibility – All the other centrifugal pumps.*
- **Two centrifugal pump (Low lift) (opt. code 80)** - *Opt. incompatibility – All the other centrifugal pumps.*
- **Two centrifugal pump (high lift) (opt. code 81)** - *Opt. incompatibility – All the other centrifugal pumps.*

Unit mounted hydronic kits are available with single and dual pumps.

The Low lift kits provides an average available head of 100 kPa at chiller standard conditions. The High lift kits provides an average available head of 200 kPa at chiller standard conditions.

The kit is completed with pressure gauge, safety valve, drain valve. The motor pump is protected by a circuit breaker installed in control panel. The kit is assembled and wired to the control panel. The pipe and pump are protected from freezing with an additional electrical heater.

In case of unit equipped with hydronic kit on board selected to operate with glycol mixture, contact factory.

Double pressure relief valve with diverter (opt. code 91)

Unit right water connection (opt. code 101) - Available on dual circuits unit only

Refrigerant leak detection (opt. code 121) Automated permanent refrigerant leak detection system installed on board. The refrigerant sensors are installed within the compressor acoustic enclosures and are specifically calibrated for R134a refrigerant. When leaks above a certain concentration are detected, the sensor sends a signal to the unit controller (a specific alarm is visualized on the unit microprocessor). The automatic shut down and pump down of refrigerant into the condensing section occurs on the detection of refrigerant leakage. The alarm threshold that triggers automatic pump down upon detection of refrigerant is set to a maximum of 2000ppm. Available only for Reduced Sound configuration.

E-coating microchannel coils (opt. code 139)

A protection a layer of an epoxy polymer is added on the surface of the exchanger. The process consists in the complete immersion of the exchanger in the epoxy polymer solution. An electric voltage applied to the exchanger causes a difference with the electrical charge of the polymer molecules that, as result, are drawn to the metal. The thickness of the coating is controlled by the applied voltage. The result is a uniform layer of epoxy polymers applied all over the exchanger surface. A final UV top-coat treatment is applied on the coil surface. The treatment is recommended in all application where high risk of corrosion exist (eg: high polluted urban, costal, industrial environments and their combinations). *Opt. incompatibility 153.*

Unit guards (to cover unit access) (opt. code 140)

Wire mesh that cover the access around the unit

Side panels on coil ends (opt. code 141)

Protection carter on both side of each condensing module.

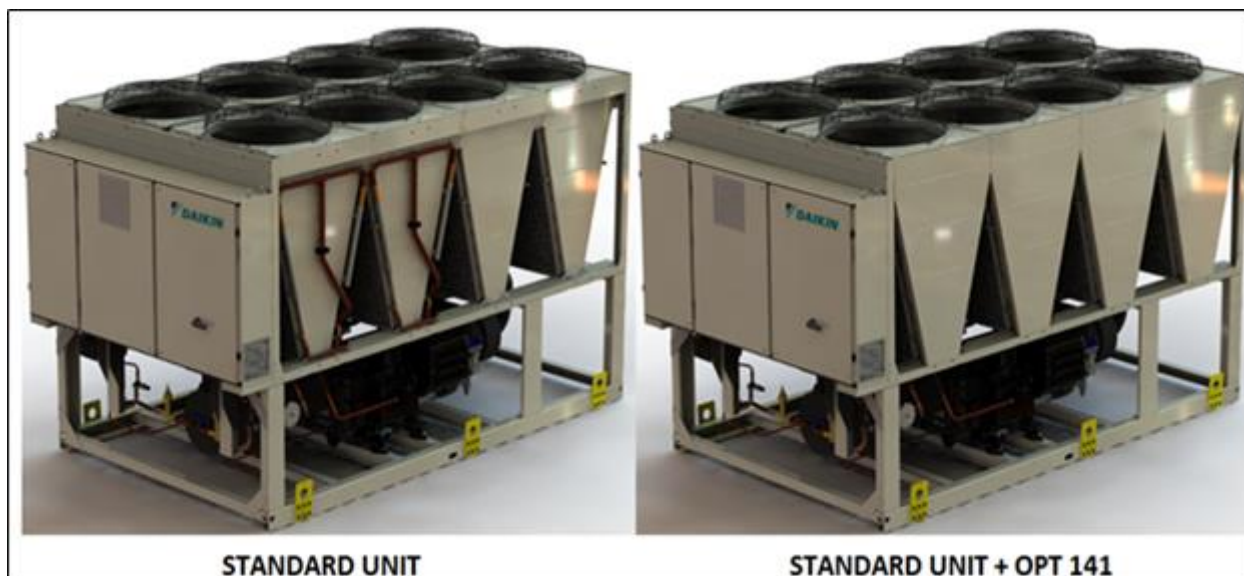

Blue coat (opt. code 153)

An epoxy powder is sprayed and electrostatically fixed to the coil. Once the surface is completely covered by the epoxy material, the coil is sent in to a furnace for the drying and curing phase. The result is an uniform and durable coating that enhance the resistance to the corrosion. The treatment is recommended in all application where moderate risk of corrosion exist (eg: urban, costal, industrial environments) - *Opt. incompatibility 139.*

Evaporator optimized for high delta T (opt. code 154) Unit performance may differ from standard. Contact factory for more details - *Opt. incompatibility 164.*

CU-NI evaporator tubes (Opt.code 164) Evaporator tubes made of Cu-Ni 90-10 material and Cu-Ni 90-10 tube sheets cladding. Epoxy ceramic coating of water headers and sacrificial anodes. Cupronickel is highly resistance to corrosion; for this reason it is used in aggressive environment. Unit performances may differ from standard. Contact factory for more details. - *Opt. incompatibility 154.*

Electrical options – On request

Energy meter (including current limit) (opt. code 16a)

Device installed inside the control box that displays all chiller electrical power parameters at line input such as line voltage and phase current, input active and reactive power, active and reactive energy, including current limit option. An integrated RS485 module allows a Modbus communication to an external BMS.

Speedtrol (opt. code 42) - *Opt. incompatibility 99a-142.*

Continuous fan speed regulation on the first fan (VFD driven) of each circuit. It allows unit operation down to -18°C (available only for SILVER version).

For GOLD and PLATINUM series the operation down to -18°C is allowed without additional options.

Evaporator flow switch (opt. code 58)

Supplied separately to be wired and installed on the evaporator water piping (by the customer). The installation of the flow switch is mandatory.

Compressors circuit breakers (opt. code 95)

Safety devices that include in a single device all safety functions otherwise provided by standard fuses and optional thermal relays, such as protection against overcurrent, overload, current unbalance - *Opt. incompatibility 11.*

Fans speed regulation (INVERTER) (opt. code 99a – provided as standard on GOLD series)

Available on Silver series as option.

Not available on Platinum series that provides the EC fans as standard.

Opt. incompatibility 42-142.

Ground fault relay (opt. code 102)

To shut down the entire unit if a ground fault condition is detected.

Rapid restart (opt. code 110)

Rapid Restart is the ideal solution for those application where we cannot afford the loose of cooling such as data centers, health care facilities, process cooling ...etc. For this kind of applications, in case of a power failure, chiller equipment are required to restore the cooling supply to the system as fast as possible. Standard unit (without the Rapid Restart option) will be starting within 310 seconds after the power is restored and it will be reaching full load cooling capacity within 20 ÷ 25 minutes (obviously depending on the load demand). Rapid Restart option includes an UPS unit for the chiller controller allowing the chiller to start in 10 seconds after power is restored and to reach full load cooling capacity in less than 3 minutes from the unit restart.

For more details about this option please refer to the Control Manual.

Inverter kit for pumps:

- **INVERTER KIT FOR 1 CENTR PUMP LOW LIFT (opt. code 120e)** – *opt. incompatibility 120f-120g-120 h.*
- **INVERTER KIT FOR 1 CENTR PUMP HIGH LIFT (opt. code 120f)** – *opt. incompatibility 120f-120g-120 h.*
- **INVERTER KIT FOR 2 CENTR PUMP LOW LIFT (opt. code 120g)** – *opt. incompatibility 120f-120g-120 h.*
- **INVERTER KIT FOR 2 CENTR PUMP HIGH LIFT (opt. code 120h)** – *opt. incompatibility 120f-120g-120 h.*

note: the Inverter kit must be associated with the corresponding hydronic kit (opt.code 78/79/80/81).

The inverter kit can be used for the following purposes:

- **Tuning the water flow during unit commissioning.**

- **Control the pump speed via external input from Building Management System (BMS)**

For this application a 0-10V signal for the pump speed must be provided from the plant manager according to the specific control strategy of the plant. The water must be within the minimum and maximum value allowed for the unit (refer to the "Operating limit" chapter). The change in water flow rate must not be exceed more than 10% of the design water flow rate per minute.

- **Set a "thermostat off" pump speed.** Providing the unit with the inverter kit for the on-board pump is possible to manage two different water flow settings. A setting for water flow during the "Thermostat ON" mode (when the chiller is actually providing cooling to the plant), and a set for the "thermostat off" mode (when the plant load is satisfied and the compressors are waiting to start). This feature allows to achieve energy saving on plant operating cost by reducing the speed of the pumps when the chiller has reached the set point.

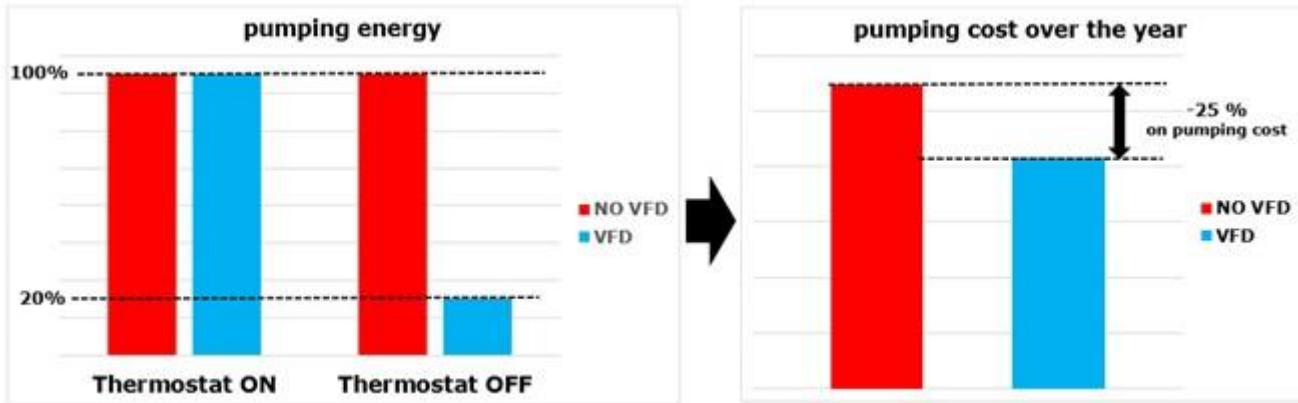

Thanks to the saving on pumping cost, the payback time for the Inverter Kit is approximately one year.

High ambient kit (opt. code 142) - Opt. incompatibility 99a-42-08.

The high ambient kit allows the operation of the unit for ambient temperature above 46°C. The set-up of the units with High ambient kit are the follows:

- **SILVER** series: includes oversized electrical equipment, enhanced ventilation for the electrical box, sunshield, 6 poles AC fans (fans speed 900 RPM).
Note: the performance will differ from the standard unit. Refer to selection software for performances.
- **GOLD & PLATINUM** series: oversized electrical equipment, enhanced ventilation for the electrical box, sunshield, EC fans (fans speed up to 900 RPM).

Note: Opt. 142 is not compatible with opt. 08 Brine

Variable Primary Flow (opt. code 143)

By selecting opt. 143 the chiller can manage the Variable Primary water flow according to the differential pressure measured in a specific point of the plant, selected by the plant designer. The differential pressure transducer, is available as option from the factory (opt. code 144). Once placed on the plant the differential pressure transducer must be connected to the unit. As alternative the unit controller can receive directly the differential pressure value from an external BMS communicating with the standards communications protocols (eg. MODBUS).

A bypass line (field supply) needs to be installed which guarantees that at all times the minimum water flow of the chiller is supplied (refer to the "Operating limit" chapter for indication on minimum water flow). The bypass valve will be an ON/OFF normally closed valve controlled by the chiller. In case the minimum water flow allowed is not reached, the chiller will open the bypass line restoring the water flow above the minimum value.

In case of multiple units installations in a primary only plant, to control the pump speed ICM is required.

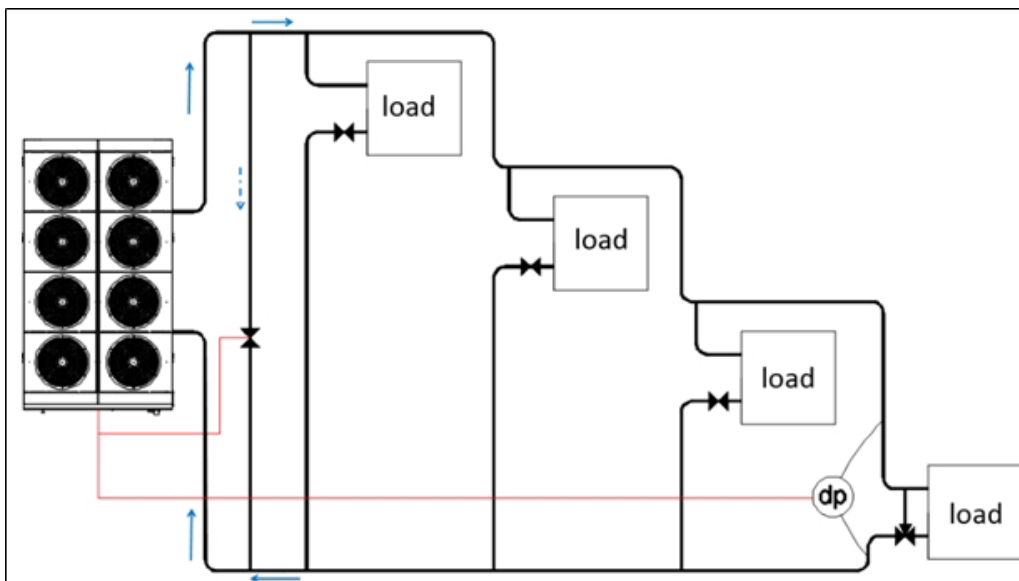

Hydronic options summarizing table

	Fixed speed	Variable speed pump (for "thermostat off" pump speed function or to be controlled with external BMS)	Variable Primary Flow management
ONE CENTRIFUGAL PUMP (LOW LIFT)	Opt 78	Opt 78 + Opt 120e	Opt 78 + Opt 120e + Opt 143
ONE CENTRIFUGAL PUMP (HIGH LIFT)	Opt 79	Opt 79 + Opt 120f	Opt 79 + Opt 120f + Opt 143
TWO CENTRIFUGAL PUMP (LOW LIFT)	Opt 80	Opt 80 + Opt 120g	Opt 80 + Opt 120g + Opt 143
TWO CENTRIFUGAL PUMP (HIGH LIFT)	Opt 81	Opt 81 + Opt 120h	Opt. 81 + Opt 120h + Opt 143

Note: opt.143 can be used only for units installed in a primary only plant to be controlled according to VPF strategy.

Differential Pressure Transducers - shipped loose - (opt. code 144).

Daikin on site modem with antenna (opt. code 155) - Whenever LAN connection to the unit will not be available, connecting the unit to Daikin on Site will be possible through a dedicated 3G M2M modem that can be ordered from Factory. When ordered, the modem will be installed on the unit before leaving the Factory.

AC 900 RPM fans (opt. code 156) - *option incompatibility 157-158-159-160-161.*
Refers to the table below in order to match the availability of the option.

AC 700 RPM fans (opt. code 157) - *option incompatibility 156-158-159-160-161.*
Refers to the table below in order to match the availability of the option.

Brushless fans up to 900 RPM fans (opt. code 158) - *option incompatibility 157-157-159-160-161-42-99a.*
Refers to the table below in order to match the availability of the option.

Brushless fans up to 700 RPM fans (opt. code 159) - *option incompatibility 156-157-160-161-42-99a.*
Refers to the table below in order to match the availability of the option.

100 PA ESP fans (opt. code 160) - *option incompatibility 156-157-158-159-161.*
Refers to the table below in order to match the availability of the option.

200 PA ESP fans (opt. code 161) - *option incompatibility 156-157-158-159-160-42-99a.*
Refers to the table below in order to match the availability of the option.

Fans options summarizing table

Model (up to 700 kW)	SS/L/R	XS/L/R	PS/L/R
AC 700 RPM FANS (opt.157)	STD	STD	NA
EC FANS UP TO 700 RPM (opt.159)	on request	on request	STD
100 PA ESP FANS (opt.160)	on request	on request	NA
200 PA ESP FANS (opt.161)	on request	CF	CF
SPEEDTROL (OPT.42)	on request	NA	NA
FANS SPEED REGULATION - INVERTER (OPT.99A)	on request	CF	CF

Model (from 820 kW)	SS/L	SR	XS/L/R	PS/L/R
AC 700 RPM FANS (opt.157)	NA	STD	STD	NA
AC 900 RPM FANS (opt.156)	STD	NA	NA	NA
EC FANS UP TO 700 RPM (opt.159)	NA	on request	on request	STD
EC FANS UP TO 900 RPM (opt.158)	on request	NA	NA	NA
100 PA ESP FANS (opt.160)	CF	on request	on request	NA
200 PA ESP FANS (opt.161)	on request	on request	CF	CF
SPEEDTROL (OPT.42)	on request	on request	NA	NA
FANS SPEED REGULATION - INVERTER (OPT.99A)	on request	on request	STD	NA

Installation options – On request

Rubber anti vibration mounts (opt. code 75) - option incompatibility 77.

Supplied separately, these are positioned under the base of the unit during installation. Ideal to reduce the vibrations when the unit is floor mounted.

Spring anti vibration mounts (opt. code 77) - option incompatibility 75.

Supplied separately, these are positioned under the base of the unit during installation. Ideal for dampening vibrations for installation on roofs and metallic structures.

External tank without cabinet – 500 L (opt. code 83)

Inertial tank for chilled water storage - *option incompatibility 84-87-88.*

External tank without cabinet – 1000 L (opt. code 84)

Inertial tank for chilled water storage - *option incompatibility 83-87-88.*

External tank with cabinet – 500 L (opt. code 87)

Inertial tank for chilled water storage with cabinet - *option incompatibility 83-84-88.*

External tank with cabinet – 1000 L (opt. code 88)

Inertial tank for chilled water storage with cabinet - *option incompatibility 83-84-87.*

Other options – On request

Container kit (opt. code 71) Several component (spacer, caps and slipping tapes) designed to ease loading/unloading of the unit into the container and to reduce risk of damage. - *option incompatibility 112.*

Transport kit (opt. code 112) A polyethylene foam (that is located below the units), that offers additional shock absorption during unit transportation. - *option incompatibility 71.*

EWAD~TZ-SS B

MODEL		EWAD160TZ -SS B1	EWAD190TZ -SS B1	EWAD240TZ -SS B1	EWAD270TZ -SS B1	EWAD300TZ -SS B1	EWAD360TZ -SS B1
COOLING PERFORMANCE							
Capacity - Cooling	kW	169	201	235	269	306	351
Capacity control - Type		Stepless	Stepless	Stepless	Stepless	Stepless	Stepless
Capacity control - Minimum capacity	%	37	31	34	29	25	24
Unit power input - Cooling	kW	56.5	69.9	83.0	89.9	108	119
EER		2.99	2.87	2.83	2.99	2.82	2.95
ESEER		4.37	4.46	4.30	4.40	4.42	4.50
IPLV		5.30	5.27	5.04	5.19	5.37	5.53
SEASONAL ENERGY EFFICIENCY ****							
SEER (12/7°C)		4.28	4.39	4.31	4.46	4.5	4.65
$\eta_{s\ cool}(12/7^\circ C)$	%	168	173	169	175	177	183
DIMENSIONS							
Height	mm	2540	2540	2540	2540	2540	2540
Width	mm	2282	2282	2282	2282	2282	2282
Length	mm	2331	2331	2331	3231	3231	4131
WEIGHT							
Unit Weight	kg	2121	2121	2121	2411	2411	2784
Operating Weight	kg	2160	2160	2160	2454	2454	2836
WATER HEAT EXCHANGER							
Type *		PHE	PHE	PHE	PHE	PHE	PHE
Water Volume	l	20	26	37	26	37	50
Water flow rate	l/s	8.1	9.6	11.2	12.9	14.6	16.8
Water pressure drop***	kPa	25.0	19.3	15.4	32.6	25.2	25.9
AIR HEAT EXCHANGER							
Type *		MCH	MCH	MCH	MCH	MCH	MCH
FAN							
Type *		DPT	DPT	DPT	DPT	DPT	DPT
Drive *		On/Off	On/Off	On/Off	On/Off	On/Off	On/Off
Diameter	mm	800	800	800	800	800	800
Nominal air flow	l/s	15109	15109	15109	22664	22664	30219
Quantity	No.	4	4	4	6	6	8
Speed	rpm	700	700	700	700	700	700
Motor input	kW	3.2	3.2	3.2	4.8	4.8	6.4
COMPRESSOR							
Oil charge	l	10.0	10.0	10.0	10.0	10.0	10.0
Quantity	No.	1	1	1	1	1	1
SOUND LEVEL **							
Sound Power - Cooling	dB(A)	96	96	96	97	98	99
Sound Pressure level@1m distance - Cooling	dB(A)	77	77	77	77	78	79
REFRIGERANT CIRCUIT							
Refrigerant type		R134a	R134a	R134a	R134a	R134a	R134a
Refrigerant charge	kg	27	29	33	38	41	52
N. of circuits	No.	1	1	1	1	1	1
PIPING CONNECTIONS							
Evaporator water inlet/outlet	mm	88.9	88.9	114.3	114.3	114.3	114.3

All the performances (Cooling capacity, unit power input in cooling and EER) are based on the following conditions: evaporator 12.0/7.0°C; ambient 35.0°C, unit at full load operation; operating fluid: Water; fouling factor = 0.

(*PHE: Plate Heat Exchanger; S&T: Single Pass Shell & Tube; MCH: Microchannel; DPT: Direct Propeller Type; DOL: Direct On Line - VFD: Inverter - BRS: Brushless

(**) Sound power level (referred to evaporator 12/7°C, ambient 35°C full load operation) are measured in accordance with ISO 9614 and Eurovent 8/1 for Eurovent certified units. The certification refers only to the overall sound power level, the sound pressure is calculated from the sound power level and are for information only and not considered binding. The minimum capacity indicated is referred to unit operating at standard Eurovent conditions. Dimensions and weights are for indication only and not considered binding. Before designing the installation, consult the official drawings available from the factory at request. All the data are referred to standard unit without options. All data are subject to change without notice.

(***) The value refers to the pressure drops in the evaporator only.

(****) In accordance with standard EN14825:2013, comfort low temperature, average climate. SEER and η_s values applicable Ecodesign regulation: (EU) No 2016/2281.

Eurovent certified values

EWAD~TZ-SS B

MODEL		EWAD380TZ -SS B2	EWAD450TZ -SS B2	EWAD495TZ -SS B2	EWAD570TZ -SS B2	EWAD610TZ -SS B2	EWAD660TZ -SS B2
COOLING PERFORMANCE							
Capacity - Cooling	kW	395	456	500	570	612	661
Capacity control - Type		Stepless	Stepless	Stepless	Stepless	Stepless	Stepless
Capacity control - Minimum capacity	%	16	17	16	14	13	12
Unit power input - Cooling	kW	139	163	174	198	217	239
EER		2.83	2.78	2.86	2.88	2.81	2.76
ESEER		4.46	4.44	4.49	4.54	4.59	4.63
IPLV		5.34	5.30	5.46	5.64	5.62	5.62
SEASONAL ENERGY EFFICIENCY ****							
SEER (12/7°C)		4.39	4.36	4.45	4.58	4.82	4.64
$\eta_{s\ cool}(12/7°C)$	%	173	171	175	180	190	183
DIMENSIONS							
Height	mm	2540	2540	2540	2540	2540	2540
Width	mm	2282	2282	2282	2282	2282	2282
Length	mm	4131	4131	5030	5887	5887	5887
WEIGHT							
Unit Weight	kg	4044	4044	4281	4588	4907	4907
Operating Weight	kg	4173	4173	4444	4751	5169	5169
WATER HEAT EXCHANGER							
Type *		S&T	S&T	S&T	S&T	S&T	S&T
Water Volume	l	158	164	158	158	270	255
Water flow rate	l/s	18.9	21.8	23.9	27.3	29.3	31.6
Water pressure drop***	kPa	25.9	32.4	44.0	55.7	38.8	32.3
AIR HEAT EXCHANGER							
Type *		MCH	MCH	MCH	MCH	MCH	MCH
FAN							
Type *		DPT	DPT	DPT	DPT	DPT	DPT
Drive *		On/Off	On/Off	On/Off	On/Off	On/Off	On/Off
Diameter	mm	800	800	800	800	800	800
Nominal air flow	l/s	30219	30219	37774	45328	45328	45328
Quantity	No.	8	8	10	12	12	12
Speed	rpm	700	700	700	700	700	700
Motor input	kW	6.4	6.4	8.0	9.6	9.6	9.6
COMPRESSOR							
Oil charge	l	20.0	20.0	20.0	20.0	20.0	20.0
Quantity	No.	2	2	2	2	2	2
SOUND LEVEL**							
Sound Power - Cooling	dB(A)	99	99	99	100	101	102
Sound Pressure level@1m distance - Cooling	dB(A)	79	79	79	80	80	82
REFRIGERANT CIRCUIT							
Refrigerant type		R134a	R134a	R134a	R134a	R134a	R134a
Refrigerant charge	kg	58	59	68	75	77	83
N. of circuits	No.	2	2	2	2	2	2
PIPING CONNECTIONS							
Evaporator water inlet/outlet	mm	139.7	139.7	139.7	139.7	168.3	168.3

All the performances (Cooling capacity, unit power input in cooling and EER) are based on the following conditions: evaporator 12.0/7.0°C; ambient 35.0°C, unit at full load operation; operating fluid: Water; fouling factor = 0.

(*)PHE: Plate Heat Exchanger; S&T: Single Pass Shell & Tube; MCH: Microchannel; DPT: Direct Propeller Type; DOL: Direct On Line - VFD: Inverter - BRS: Brushless

(**) Sound power level (referred to evaporator 12/7°C, ambient 35°C full load operation) are measured in accordance with ISO 9614 and Eurovent 8/1 for Eurovent certified units. The certification refers only to the overall sound power level, the sound pressure is calculated from the sound power level and are for information only and not considered binding. The minimum capacity indicated is referred to unit operating at standard Eurovent conditions. Dimensions and weights are for indication only and not considered binding. Before designing the installation, consult the official drawings available from the factory at request. All the data are referred to standard unit without options. All data are subject to change without notice.

(***) The value refers to the pressure drops in the evaporator only.

(****) In accordance with standard EN14825:2013, comfort low temperature, average climate. SEER and η_s values applicable Ecodesign regulation: (EU) No 2016/2281.

Eurovent certified values

EWAD~TZ-SS B

MODEL		EWAD700TZ -SS B2	EWAD820TZ -SS B2	EWAD900TZ -SS B2	EWAD990TZ -SS B2	EWADC10TZ -SS B2	EWADC11TZ -SS B2
COOLING PERFORMANCE							
Capacity - Cooling	kW	701	816	890	987	1,045	1,104
Capacity control - Type		Stepless	Stepless	Stepless	Stepless	Stepless	Stepless
Capacity control - Minimum capacity	%	12	10	10	10	10	10
Unit power input - Cooling	kW	249	257	296	321	346	366
EER		2.81	3.16	3.01	3.07	3.02	3.02
ESEER		4.70	4.43	4.44	4.44	4.44	4.51
IPLV		5.70	5.29	5.26	5.25	5.26	5.27
SEASONAL ENERGY EFFICIENCY ****							
SEER (12/7°C)		4.71	5.01	4.93	5.09	5.08	5.09
$\eta_{s,cool}(12/7°C)$	%	185	197	194	201	200	201
DIMENSIONS							
Height	mm	2540	2540	2540	2540	2540	2540
Width	mm	2282	2282	2282	2282	2282	2282
Length	mm	6786	6877	6877	7787	8687	9625
WEIGHT							
Unit Weight	kg	5078	5744	6026	6310	6652	6930
Operating Weight	kg	5341	6024	6306	6760	7102	7380
WATER HEAT EXCHANGER							
Type *		S&T	S&T	S&T	S&T	S&T	S&T
Water Volume	l	255	283	485	485	485	453
Water flow rate	l/s	33.5	39.1	42.6	47.2	50.0	52.8
Water pressure drop***	kPa	36.0	52.6	36.9	42.2	46.6	37.3
Insulation material *		CC	CC	CC	CC	CC	CC
AIR HEAT EXCHANGER							
Type *		MCH	MCH	MCH	MCH	MCH	MCH
FAN							
Type *		DPT	DPT	DPT	DPT	DPT	DPT
Drive *		On/Off	On/Off	On/Off	On/Off	On/Off	On/Off
Diameter	mm	800	800	800	800	800	800
Nominal air flow	l/s	52883	69177	69177	79060	88942	98825
Quantity	No.	14	14	14	16	18	20
Speed	rpm	700	900	900	900	900	900
Motor input	kW	11.2	24.5	24.5	28.0	31.5	35.0
COMPRESSOR							
Oil charge	l	20.0	36.0	36.0	36.0	36.0	36.0
Quantity	No.	2	2	2	2	2	2
SOUND LEVEL**							
Sound Power - Cooling	dB(A)	105	102	102	102	103	103
Sound Pressure level@1m distance - Cooling	dB(A)	84	81	81	81	81	81
REFRIGERANT CIRCUIT							
Refrigerant type		R134a	R134a	R134a	R134a	R134a	R134a
Refrigerant charge	kg	90	91	91	104	117	130
N. of circuits	No.	2	2	2	2	2	2
PIPING CONNECTIONS							
Evaporator water inlet/outlet	mm	168.3	168.3	219.1	219.1	219.1	219.1

All the performances (Cooling capacity, unit power input in cooling and EER) are based on the following conditions: evaporator 12.0/7.0°C; ambient 35.0°C, unit at full load operation; operating fluid: Water; fouling factor = 0.

(*):PHE: Plate Heat Exchanger; S&T: Single Pass Shell & Tube; MCH: Microchannel; DPT: Direct Propeller Type; DOL: Direct On Line - VFD: Inverter - BRS: Brushless

(**) Sound power level (referred to evaporator 12/7°C, ambient 35°C full load operation) are measured in accordance with ISO 9614 and Eurovent 8/1 for Eurovent certified units. The certification refers only to the overall sound power level, the sound pressure is calculated from the sound power level and are for information only and not considered binding. The minimum capacity indicated is referred to unit operating at standard Eurovent conditions. Dimensions and weights are for indication only and not considered binding. Before designing the installation, consult the official drawings available from the factory at request. All the data are referred to standard unit without options. All data are subject to change without notice.

(***) The value refers to the pressure drops in the evaporator only. (****) In accordance with standard EN14825:2013, comfort low temperature, average climate. SEER and η_s values applicable Ecodesign regulation: (EU) No 2016/2281.

Eurovent certified values

EWAD~TZ-SL B

MODEL		EWAD160TZ -SL B1	EWAD190TZ -SL B1	EWAD240TZ -SL B1	EWAD270TZ -SL B1	EWAD300TZ -SL B1	EWAD360TZ -SL B1
COOLING PERFORMANCE							
Capacity - Cooling	kW	169	201	235	269	306	351
Capacity control - Type		Stepless	Stepless	Stepless	Stepless	Stepless	Stepless
Capacity control - Minimum capacity	%	37	31	34	29	25	24
Unit power input - Cooling	kW	56.5	69.9	83.0	89.9	108	119
EER		2.99	2.87	2.83	2.99	2.82	2.95
ESEER		4.37	4.46	4.30	4.40	4.42	4.50
IPLV		5.30	5.27	5.04	5.19	5.37	5.53
SEASONAL ENERGY EFFICIENCY ****							
SEER (12/7°C)		4.28	4.39	4.31	4.46	4.5	4.65
$\eta_{s\ cool}(12/7°C)$	%	168	173	169	175	177	183
DIMENSIONS							
Height	mm	2540	2540	2540	2540	2540	2540
Width	mm	2282	2282	2282	2282	2282	2282
Length	mm	2331	2331	2331	3231	3231	4131
WEIGHT							
Unit Weight	kg	2121	2121	2121	2411	2411	2784
Operating Weight	kg	2160	2160	2160	2454	2454	2836
WATER HEAT EXCHANGER							
Type *		PHE	PHE	PHE	PHE	PHE	PHE
Water Volume	l	20	26	37	26	37	50
Water flow rate	l/s	8.1	9.6	11.2	12.9	14.6	16.8
Water pressure drop***	kPa	25.0	19.3	15.4	32.6	25.2	25.9
AIR HEAT EXCHANGER							
Type *		MCH	MCH	MCH	MCH	MCH	MCH
FAN							
Type *		DPT	DPT	DPT	DPT	DPT	DPT
Drive *		On/Off	On/Off	On/Off	On/Off	On/Off	On/Off
Diameter	mm	800	800	800	800	800	800
Nominal air flow	l/s	15109	15109	15109	22664	22664	30219
Quantity	No.	4	4	4	6	6	8
Speed	rpm	700	700	700	700	700	700
Motor input	kW	3.2	3.2	3.2	4.8	4.8	6.4
COMPRESSOR							
Oil charge	l	10.0	10.0	10.0	10.0	10.0	10.0
Quantity	No.	1	1	1	1	1	1
SOUND LEVEL**							
Sound Power - Cooling	dB(A)	90	90	90	91	92	93
Sound Pressure level@1m distance - Cooling	dB(A)	71	72	72	72	73	74
REFRIGERANT CIRCUIT							
Refrigerant type		R134a	R134a	R134a	R134a	R134a	R134a
Refrigerant charge	kg	27	29	33	38	41	52
N. of circuits	No.	1	1	1	1	1	1
PIPING CONNECTIONS							
Evaporator water inlet/outlet	mm	88.9	88.9	114.3	114.3	114.3	114.3

All the performances (Cooling capacity, unit power input in cooling and EER) are based on the following conditions: evaporator 12.0/7.0°C; ambient 35.0°C, unit at full load operation; operating fluid: Water; fouling factor = 0.

(*PHE: Plate Heat Exchanger; S&T: Single Pass Shell & Tube; MCH: Microchannel; DPT: Direct Propeller Type; DOL: Direct On Line - VFD; Inverter - BRS: Brushless

(**) Sound power level (referred to evaporator 12/7°C, ambient 35°C full load operation) are measured in accordance with ISO 9614 and Eurovent 8/1 for Eurovent certified units. The certification refers only to the overall sound power level, the sound pressure is calculated from the sound power level and are for information only and not considered binding. The minimum capacity indicated is referred to unit operating at standard Eurovent conditions. Dimensions and weights are for indication only and not considered binding. Before designing the installation, consult the official drawings available from the factory at request. All the data are referred to standard unit without options. All data are subject to change without notice.

(***) The value refers to the pressure drops in the evaporator only.

(****) In accordance with standard EN14825:2013, comfort low temperature, average climate. SEER and η_s values applicable Ecodesign regulation: (EU) No 2016/2281.

Eurovent certified values

EWAD~TZ-SL B

MODEL		EWAD380TZ -SL B2	EWAD450TZ -SL B2	EWAD495TZ -SL B2	EWAD570TZ -SL B2	EWAD610TZ -SL B2	EWAD660TZ -SL B2
COOLING PERFORMANCE							
Capacity - Cooling	kW	395	456	500	570	612	661
Capacity control - Type		Stepless	Stepless	Stepless	Stepless	Stepless	Stepless
Capacity control - Minimum capacity	%	16	17	16	14	13	12
Unit power input - Cooling	kW	139	163	174	198	217	239
EER		2.83	2.78	2.86	2.88	2.81	2.76
ESEER		4.46	4.44	4.49	4.54	4.59	4.63
IPLV		5.34	5.30	5.46	5.64	5.62	5.62
SEASONAL ENERGY EFFICIENCY ****							
SEER (12/7°C)		4.39	4.36	4.45	4.58	4.82	4.64
$\eta_{s\ cool}(12/7°C)$	%	173	171	175	180	190	183
DIMENSIONS							
Height	mm	2540	2540	2540	2540	2540	2540
Width	mm	2282	2282	2282	2282	2282	2282
Length	mm	4131	4131	5030	5887	5887	5887
WEIGHT							
Unit Weight	kg	4044	4044	4281	4588	4907	4907
Operating Weight	kg	4173	4173	4444	4751	5169	5169
WATER HEAT EXCHANGER							
Type *		S&T	S&T	S&T	S&T	S&T	S&T
Water Volume	l	158	164	158	158	270	255
Water flow rate	l/s	18.9	21.8	23.9	27.3	29.3	31.6
Water pressure drop***	kPa	25.9	32.4	44.0	55.7	38.8	32.3
AIR HEAT EXCHANGER							
Type *		MCH	MCH	MCH	MCH	MCH	MCH
FAN							
Type *		DPT	DPT	DPT	DPT	DPT	DPT
Drive *		On/Off	On/Off	On/Off	On/Off	On/Off	On/Off
Diameter	mm	800	800	800	800	800	800
Nominal air flow	l/s	30219	30219	37774	45328	45328	45328
Quantity	No.	8	8	10	12	12	12
Speed	rpm	700	700	700	700	700	700
Motor input	kW	6.4	6.4	8.0	9.6	9.6	9.6
COMPRESSOR							
Oil charge	l	20.0	20.0	20.0	20.0	20.0	20.0
Quantity	No.	2	2	2	2	2	2
SOUND LEVEL**							
Sound Power - Cooling	dB(A)	93	93	94	94	95.5	96.5
Sound Pressure level@1m distance - Cooling	dB(A)	74	74	74	74	75	76
REFRIGERANT CIRCUIT							
Refrigerant type		R134a	R134a	R134a	R134a	R134a	R134a
Refrigerant charge	kg	58	59	68	75	77	83
N. of circuits	No.	2	2	2	2	2	2
PIPING CONNECTIONS							
Evaporator water inlet/outlet	mm	139.7	139.7	139.7	139.7	168.3	168.3

All the performances (Cooling capacity, unit power input in cooling and EER) are based on the following conditions: evaporator 12.0/7.0°C; ambient All the performances (Cooling capacity, unit power input in cooling and EER) are based on the following conditions: evaporator 12.0/7.0°C; ambient 35.0°C, unit at full load operation; operating fluid: Water; fouling factor = 0.

(*PHE: Plate Heat Exchanger; S&T: Single Pass Shell & Tube; MCH: Microchannel; DPT: Direct Propeller Type; DOL: Direct On Line - VFD: Inverter - BRS: Brushless

(**) Sound power level (referred to evaporator 12/7°C, ambient 35°C full load operation) are measured in accordance with ISO 9614 and Eurovent 8/1 for Eurovent certified units. The certification refers only to the overall sound power level, the sound pressure is calculated from the sound power level and are for information only and not considered binding. The minimum capacity indicated is referred to unit operating at standard Eurovent conditions. Dimensions and weights are for indication only and not considered binding. Before designing the installation, consult the official drawings available from the factory at request. All the data are referred to standard unit without options. All data are subject to change without notice.

(***) The value refers to the pressure drops in the evaporator only.

(****) In accordance with standard EN14825:2013, comfort low temperature, average climate. SEER and η_s values applicable Ecodesign regulation: (EU) No 2016/2281.

Eurovent certified values

EWAD~TZ-SL B

MODEL		EWAD700TZ -SL B2	EWAD820TZ -SL B2	EWAD900TZ -SL B2	EWAD990TZ -SL B2	EWADC10TZ -SL B2	EWADC11TZ -SL B2
COOLING PERFORMANCE							
Capacity - Cooling	kW	701	816	890	987	1,045	1,104
Capacity control - Type		Stepless	Stepless	Stepless	Stepless	Stepless	Stepless
Capacity control - Minimum capacity	%	12	10	10	10	10	10
Unit power input - Cooling	kW	249	257	296	321	346	366
EER		2.81	3.16	3.01	3.07	3.02	3.02
ESEER		4.70	4.43	4.44	4.44	4.44	4.51
IPLV		5.70	5.29	5.26	5.25	5.26	5.27
SEASONAL ENERGY EFFICIENCY ****							
SEER (12/7°C)		4.71	5.01	4.93	5.09	5.08	5.09
$\eta_{s\ cool}(12/7°C)$	%	185	197	194	201	200	201
DIMENSIONS							
Height	mm	2540	2540	2540	2540	2540	2540
Width	mm	2282	2282	2282	2282	2282	2282
Length	mm	6786	6877	6877	7787	8687	9625
WEIGHT							
Unit Weight	kg	5104	5744	6026	6310	6652	6930
Operating Weight	kg	5359	6024	6306	6760	7102	7380
WATER HEAT EXCHANGER							
Type *		S&T	S&T	S&T	S&T	S&T	S&T
Water Volume	l	255	283	485	485	485	453
Water flow rate	l/s	33.5	39.1	42.6	47.2	50.0	52.8
Water pressure drop***	kPa	36.0	52.6	36.9	42.2	46.6	37.3
AIR HEAT EXCHANGER							
Type *		MCH	MCH	MCH	MCH	MCH	MCH
FAN							
Type *		DPT	DPT	DPT	DPT	DPT	DPT
Drive *		On/Off	On/Off	On/Off	On/Off	On/Off	On/Off
Diameter	mm	800	800	800	800	800	800
Nominal air flow	l/s	52883	69177	69177	79060	88942	98825
Quantity	No.	14	14	14	16	18	20
Speed	rpm	700	900	900	900	900	900
Motor input	kW	11.2	24.5	24.5	28.0	31.5	35.0
COMPRESSOR							
Oil charge	l	20.0	36.0	36.0	36.0	36.0	36.0
Quantity	No.	2	2	2	2	2	2
SOUND LEVEL **							
Sound Power - Cooling	dB(A)	98	99	99	99	100	100
Sound Pressure level@1m distance - Cooling	dB(A)	77	78	78	78	78	78
REFRIGERANT CIRCUIT							
Refrigerant type		R134a	R134a	R134a	R134a	R134a	R134a
Refrigerant charge	kg	90	91	91	104	117	130
N. of circuits	No.	2	2	2	2	2	2
PIPING CONNECTIONS							
Evaporator water inlet/outlet	mm	168.3	168.3	219.1	219.1	219.1	219.1

All the performances (Cooling capacity, unit power input in cooling and EER) are based on the following conditions: evaporator 12.0/7.0°C; ambient 35.0°C, unit at full load operation; operating fluid: Water; fouling factor = 0.

(*)PHE: Plate Heat Exchanger; S&T: Single Pass Shell & Tube; MCH: Microchannel; DPT: Direct Propeller Type; DOL: Direct On Line - VFD: Inverter - BRS: Brushless

(**) Sound power level (referred to evaporator 12/7°C, ambient 35°C full load operation) are measured in accordance with ISO 9614 and Eurovent 8/1 for Eurovent certified units. The certification refers only to the overall sound power level, the sound pressure is calculated from the sound power level and are for information only and not considered binding. The minimum capacity indicated is referred to unit operating at standard Eurovent conditions. Dimensions and weights are for indication only and not considered binding. Before designing the installation, consult the official drawings available from the factory at request. All the data are referred to standard unit without options. All data are subject to change without notice.

(***) The value refers to the pressure drops in the evaporator only.

(****) In accordance with standard EN14825:2013, comfort low temperature, average climate. SEER and η_s values applicable Ecodesign regulation: (EU) No 2016/2281.

Eurovent certified values

EWAD~TZ-SR B

MODEL		EWAD160TZ -SR B1	EWAD190TZ -SR B1	EWAD240TZ -SR B1	EWAD270TZ -SR B1	EWAD300TZ -SR B1	EWAD360TZ -SR B1
COOLING PERFORMANCE							
Capacity - Cooling	kW	169	201	235	269	306	351
Capacity control - Type		Stepless	Stepless	Stepless	Stepless	Stepless	Stepless
Capacity control - Minimum capacity	%	37	31	34	29	25	24
Unit power input - Cooling	kW	56.5	69.9	83.0	89.9	108	119
EER		2.99	2.87	2.83	2.99	2.82	2.95
ESEER		4.37	4.46	4.30	4.40	4.42	4.50
IPLV		5.30	5.27	5.04	5.19	5.37	5.53
SEASONAL ENERGY EFFICIENCY ****							
SEER (12/7°C)		4.28	4.39	4.31	4.46	4.5	4.65
$\eta_{s\ cool}(12/7°C)$	%	168	173	169	175	177	183
DIMENSIONS							
Height	mm	2540	2540	2540	2540	2540	2540
Width	mm	2282	2282	2282	2282	2282	2282
Length	mm	2331	2331	2331	3231	3231	4131
WEIGHT							
Unit Weight	kg	2121	2121	2121	2411	2411	2784
Operating Weight	kg	2160	2160	2160	2454	2454	2836
WATER HEAT EXCHANGER							
Type *		PHE	PHE	PHE	PHE	PHE	PHE
Water Volume	l	20	26	37	26	37	50
Water flow rate	l/s	8.1	9.6	11.2	12.9	14.6	16.8
Water pressure drop***	kPa	25.0	19.3	15.4	32.6	25.2	25.9
AIR HEAT EXCHANGER							
Type *		MCH	MCH	MCH	MCH	MCH	MCH
FAN							
Type *		DPT	DPT	DPT	DPT	DPT	DPT
Drive *		On/Off	On/Off	On/Off	On/Off	On/Off	On/Off
Diameter	mm	800	800	800	800	800	800
Nominal air flow	l/s	15109	15109	15109	22664	22664	30219
Quantity	No.	4	4	4	6	6	8
Speed	rpm	700	700	700	700	700	700
Motor input	kW	3.2	3.2	3.2	4.8	4.8	6.4
COMPRESSOR							
Oil charge	l	10.0	10.0	10.0	10.0	10.0	10.0
Quantity	No.	1	1	1	1	1	1
SOUND LEVEL**							
Sound Power - Cooling	dB(A)	86	87	87	88	88	90
Sound Pressure level@1m distance - Cooling	dB(A)	67	68	68	68	69	70
REFRIGERANT CIRCUIT							
Refrigerant type		R134a	R134a	R134a	R134a	R134a	R134a
Refrigerant charge	kg	27	29	33	38	41	52
N. of circuits	No.	1	1	1	1	1	1
PIPING CONNECTIONS							
Evaporator water inlet/outlet	mm	88.9	88.9	114.3	114.3	114.3	114.3

All the performances (Cooling capacity, unit power input in cooling and EER) are based on the following conditions: evaporator 12.0/7.0°C; ambient 35.0°C, unit at full load operation; operating fluid: Water; fouling factor = 0.

(*)PHE: Plate Heat Exchanger; S&T: Single Pass Shell & Tube; MCH: Microchannel; DPT: Direct Propeller Type; DOL: Direct On Line - VFD: Inverter - BRS: Brushless

(**) Sound power level (referred to evaporator 12/7°C, ambient 35°C full load operation) are measured in accordance with ISO 9614 and Eurovent 8/1 for Eurovent certified units. The certification refers only to the overall sound power level, the sound pressure is calculated from the sound power level and are for information only and not considered binding. The minimum capacity indicated is referred to unit operating at standard Eurovent conditions. Dimensions and weights are for indication only and not considered binding. Before designing the installation, consult the official drawings available from the factory at request. All the data are referred to standard unit without options. All data are subject to change without notice.

(***) The value refers to the pressure drops in the evaporator only.

(****) In accordance with standard EN14825:2013, comfort low temperature, average climate. SEER and η_s values applicable Ecodesign regulation: (EU) No 2016/2281.

Eurovent certified values

EWAD~TZ-SR B

MODEL		EWAD380TZ -SR B2	EWAD450TZ -SR B2	EWAD495TZ -SR B2	EWAD570TZ -SR B2	EWAD610TZ -SR B2	EWAD660TZ -SR B2
COOLING PERFORMANCE							
Capacity - Cooling	kW	394	455	499	569	610	659
Capacity control - Type		Stepless	Stepless	Stepless	Stepless	Stepless	Stepless
Capacity control - Minimum capacity	%	16	17	16	14	13	12
Unit power input - Cooling	kW	140	164	175	199	218	240
EER		2.81	2.76	2.85	2.86	2.80	2.74
ESEER		4.44	4.43	4.47	4.53	4.61	4.60
IPLV		5.30	5.26	5.43	5.60	5.61	5.60
SEASONAL ENERGY EFFICIENCY ****							
SEER (12/7°C)		4.38	4.34	4.43	4.56	4.79	4.62
$\eta_{s\ cool}(12/7°C)$	%	172	171	174	179	189	182
DIMENSIONS							
Height	mm	2540	2540	2540	2540	2540	2540
Width	mm	2282	2282	2282	2282	2282	2282
Length	mm	4131	4131	5030	5887	5887	5887
WEIGHT							
Unit Weight	kg	4044	4044	4281	4588	4907	4907
Operating Weight	kg	4173	4173	4444	4751	5169	5169
WATER HEAT EXCHANGER							
Type *		S&T	S&T	S&T	S&T	S&T	S&T
Water Volume	l	158	164	158	158	270	255
Water flow rate	l/s	18.8	21.7	23.9	27.2	29.2	31.5
Water pressure drop***	kPa	25.8	32.2	43.9	55.5	38.6	32.2
AIR HEAT EXCHANGER							
Type *		MCH	MCH	MCH	MCH	MCH	MCH
FAN							
Type *		DPT	DPT	DPT	DPT	DPT	DPT
Drive *		On/Off	On/Off	On/Off	On/Off	On/Off	On/Off
Diameter	mm	800	800	800	800	800	800
Nominal air flow	l/s	29650	29650	36920	44475	44475	44475
Quantity	No.	8	8	10	12	12	12
Speed	rpm	700	700	700	700	700	700
Motor input	kW	6.4	6.4	8.0	9.6	9.6	9.6
COMPRESSOR							
Oil charge	l	20.0	20.0	20.0	20.0	20.0	20.0
Quantity	No.	2	2	2	2	2	2
SOUND LEVEL**							
Sound Power - Cooling	dB(A)	90	90	90	91	91	92
Sound Pressure level@1m distance - Cooling	dB(A)	70	70	70	70	70	71
REFRIGERANT CIRCUIT							
Refrigerant type		R134a	R134a	R134a	R134a	R134a	R134a
Refrigerant charge	kg	58	59	68	75	77	83
N. of circuits	No.	2	2	2	2	2	2
PIPING CONNECTIONS							
Evaporator water inlet/outlet	mm	139.7	139.7	139.7	139.7	168.3	168.3

All the performances (Cooling capacity, unit power input in cooling and EER) are based on the following conditions: evaporator 12.0/7.0°C; ambient 35.0°C, unit at full load operation; operating fluid: Water; fouling factor = 0.

(*)PHE: Plate Heat Exchanger; S&T: Single Pass Shell & Tube; MCH: Microchannel; DPT: Direct Propeller Type; DOL: Direct On Line - VFD: Inverter - BRS: Brushless

(**) Sound power level (referred to evaporator 12/7°C, ambient 35°C full load operation) are measured in accordance with ISO 9614 and Eurovent 8/1 for Eurovent certified units. The certification refers only to the overall sound power level, the sound pressure is calculated from the sound power level and are for information only and not considered binding. The minimum capacity indicated is referred to unit operating at standard Eurovent conditions. Dimensions and weights are for indication only and not considered binding. Before designing the installation, consult the official drawings available from the factory at request. All the data are referred to standard unit without options. All data are subject to change without notice.

(***) The value refers to the pressure drops in the evaporator only.

(****) In accordance with standard EN14825:2013, comfort low temperature, average climate. SEER and η_s values applicable Ecodesign regulation: (EU) No 2016/2281.

Eurovent certified values

EWAD~TZ-SR B

MODEL		EWAD700TZ -SR B2	EWAD820TZ -SR B2	EWAD900TZ -SR B2	EWAD990TZ -SR B2	EWADC10TZ -SR B2	EWADC11TZ -SR B2
COOLING PERFORMANCE							
Capacity - Cooling	kW	700	800	895	956	1,013	1,067
Capacity control - Type		Stepless	Stepless	Stepless	Stepless	Stepless	Stepless
Capacity control - Minimum capacity	%	12	10	10	10	10	10
Unit power input - Cooling	kW	250	247	294	317	335	358
EER		2.80	3.23	3.04	3.02	3.02	2.97
ESEER		4.68	4.80	4.80	4.85	4.83	4.98
IPLV		5.67	5.92	5.74	5.77	5.75	5.86
SEASONAL ENERGY EFFICIENCY ****							
SEER (12/7°C)		4.69	5.45	5.41	5.42	5.48	5.52
$\eta_{s\ cool}(12/7^\circ C)$	%	185	215	213	214	216	218
DIMENSIONS							
Height	mm	2540	2540	2540	2540	2540	2540
Width	mm	2282	2282	2282	2282	2282	2282
Length	mm	6786	7787	7787	8687	9587	10488
WEIGHT							
Unit Weight	kg	5104	6178	6310	6652	6930	7258
Operating Weight	kg	5359	6458	6760	7102	7380	7708
WATER HEAT EXCHANGER							
Type *		S&T	S&T	S&T	S&T	S&T	S&T
Water Volume	l	255	283	485	485	485	453
Water flow rate	l/s	33.5	38.3	42.8	45.7	48.5	51.0
Water pressure drop***	kPa	35.9	52.1	36.3	41.0	45.6	36.3
AIR HEAT EXCHANGER							
Type *		MCH	MCH	MCH	MCH	MCH	MCH
FAN							
Type *		DPT	DPT	DPT	DPT	DPT	DPT
Drive *		On/Off	On/Off	On/Off	On/Off	On/Off	On/Off
Diameter	mm	800	800	800	800	800	800
Nominal air flow	l/s	51745	59299	59299	66570	74124	81394
Quantity	No.	14	16	16	18	20	22
Speed	rpm	700	700	700	700	700	700
Motor input	kW	11.2	12.8	12.8	14.4	16.0	17.6
COMPRESSOR							
Oil charge	l	20.0	36.0	36.0	36.0	36.0	36.0
Quantity	No.	2	2	2	2	2	2
SOUND LEVEL **							
Sound Power - Cooling	dB(A)	94	94	94	94	94	95
Sound Pressure level@1m distance - Cooling	dB(A)	73	73	73	73	73	73
REFRIGERANT CIRCUIT							
Refrigerant type		R134a	R134a	R134a	R134a	R134a	R134a
Refrigerant charge	kg	90	104	104	117	130	143
N. of circuits	No.	2	2	2	2	2	2
PIPING CONNECTIONS							
Evaporator water inlet/outlet	mm	168.3	168.3	219.1	219.1	219.1	219.1

All the performances (Cooling capacity, unit power input in cooling and EER) are based on the following conditions: evaporator 12.0/7.0°C; ambient 35.0°C, unit at full load operation; operating fluid: Water; fouling factor = 0.

(*)PHE: Plate Heat Exchanger; S&T: Single Pass Shell & Tube; MCH: Microchannel; DPT: Direct Propeller Type; DOL: Direct On Line - VFD: Inverter - BRS: Brushless

(**) Sound power level (referred to evaporator 12/7°C, ambient 35°C full load operation) are measured in accordance with ISO 9614 and Eurovent 8/1 for Eurovent certified units. The certification refers only to the overall sound power level, the sound pressure is calculated from the sound power level and are for information only and not considered binding. The minimum capacity indicated is referred to unit operating at standard Eurovent conditions. Dimensions and weights are for indication only and not considered binding. Before designing the installation, consult the official drawings available from the factory at request. All the data are referred to standard unit without options. All data are subject to change without notice.

(***) The value refers to the pressure drops in the evaporator only.

(****) In accordance with standard EN14825:2013, comfort low temperature, average climate. SEER and η_s values applicable Ecodesign regulation: (EU) No 2016/2281.

Eurovent certified values

EWAD~TZ-XS B

MODEL		EWAD190TZ -XS B1	EWAD220TZ -XS B1	EWAD240TZ -XS B1	EWAD290TZ -XS B1	EWAD320TZ -XS B1	EWAD360TZ -XS B2
COOLING PERFORMANCE							
Capacity - Cooling	kW	180	211	240	277	313	361
Capacity control - Type		Stepless	Stepless	Stepless	Stepless	Stepless	Stepless
Capacity control - Minimum capacity	%	34	29	34	29	25	17
Unit power input - Cooling	kW	52.1	63.2	72.5	83.9	100	109
EER		3.46	3.34	3.30	3.30	3.13	3.30
ESEER		5.11	5.06	4.99	5.09	5.13	5.14
IPLV		6.26	6.15	6.19	6.17	6.17	6.40
SEASONAL ENERGY EFFICIENCY ****							
SEER (12/7°C)		4.95	5.04	4.96	5.15	5.14	4.96
$\eta_{s\ cool}(12/7^\circ C)$	%	195	199	195	203	203	195
DIMENSIONS							
Height	mm	2540	2540	2540	2540	2540	2540
Width	mm	2282	2282	2282	2282	2282	2282
Length	mm	3231	3231	4131	4131	5030	5030
WEIGHT							
Unit Weight	kg	2411	2411	2411	2784	2784	4281
Operating Weight	kg	2454	2454	2454	2836	2836	4444
WATER HEAT EXCHANGER							
Type *		PHE	PHE	PHE	PHE	PHE	S&T
Water Volume	l	26	37	37	50	50	158
Water flow rate	l/s	8.6	10.1	11.5	13.2	15.0	17.3
Water pressure drop***	kPa	16.4	13.2	16.2	17.1	21.0	34.3
AIR HEAT EXCHANGER							
Type *		MCH	MCH	MCH	MCH	MCH	MCH
FAN							
Type *		DPT	DPT	DPT	DPT	DPT	DPT
Drive *		VFD	VFD	VFD	VFD	VFD	VFD
Diameter	mm	800	800	800	800	800	800
Nominal air flow	l/s	22664	22664	22664	30219	30219	37774
Quantity	No.	6	6	6	8	8	10
Speed	rpm	700	700	700	700	700	700
Motor input	kW	4.8	4.8	4.8	6.4	6.4	8.0
COMPRESSOR							
Oil charge	l	10.0	10.0	10.0	10.0	10.0	20.0
Quantity	No.	1	1	1	1	1	2
SOUND LEVEL**							
Sound Power - Cooling	dB(A)	96	97	96	97	98	99
Sound Pressure level@1m distance - Cooling	dB(A)	77	77	77	77	78	79
REFRIGERANT CIRCUIT							
Refrigerant type		R134a	R134a	R134a	R134a	R134a	R134a
Refrigerant charge	kg	36	39	40	51	51	64
N. of circuits	No.	1	1	1	1	1	2
PIPING CONNECTIONS							
Evaporator water inlet/outlet	mm	88.9	88.9	114.3	114.3	114.3	139.7

All the performances (Cooling capacity, unit power input in cooling and EER) are based on the following conditions: evaporator 12.0/7.0°C; ambient 35.0°C, unit at full load operation; operating fluid: Water; fouling factor = 0.

(*)PHE: Plate Heat Exchanger; S&T: Single Pass Shell & Tube; MCH: Microchannel; DPT: Direct Propeller Type; DOL: Direct On Line - VFD: Inverter - BRS: Brushless

(**) Sound power level (referred to evaporator 12/7°C, ambient 35°C full load operation) are measured in accordance with ISO 9614 and Eurovent 8/1 for Eurovent certified units. The certification refers only to the overall sound power level, the sound pressure is calculated from the sound power level and are for information only and not considered binding. The minimum capacity indicated is referred to unit operating at standard Eurovent conditions. Dimensions and weights are for indication only and not considered binding. Before designing the installation, consult the official drawings available from the factory at request. All the data are referred to standard unit without options. All data are subject to change without notice.

(***) The value refers to the pressure drops in the evaporator only.

(****) In accordance with standard EN14825:2013, comfort low temperature, average climate. SEER and η_s values applicable Ecodesign regulation: (EU) No 2016/2281.

Eurovent certified values

EWAD~TZ-XS B

MODEL		EWAD420TZ -XS B2	EWAD450TZ -XS B2	EWAD540TZ -XS B2	EWAD570TZ -XS B2	EWAD610TZ -XS B2	EWAD660TZ -XS B2
COOLING PERFORMANCE							
Capacity - Cooling	kW	417	473	529	563	599	639
Capacity control - Type		Stepless	Stepless	Stepless	Stepless	Stepless	Stepless
Capacity control - Minimum capacity	%	16	17	16	15	14	13
Unit power input - Cooling	kW	132	144	163	181	191	202
EER		3.16	3.26	3.24	3.11	3.13	3.16
ESEER		5.09	5.00	5.07	5.07	5.11	5.15
IPLV		6.30	6.22	6.22	6.29	6.31	6.25
SEASONAL ENERGY EFFICIENCY ****							
SEER (12/7°C)		5.03	5.07	5.1	5.04	5.17	5.23
$\eta_{s\ cool}(12/7^\circ C)$	%	198	200	201	199	204	206
DIMENSIONS							
Height	mm	2540	2540	2540	2540	2540	2540
Width	mm	2282	2282	2282	2282	2282	2282
Length	mm	5030	5887	5887	5887	6786	7684
WEIGHT							
Unit Weight	kg	4281	4588	4907	4907	5078	5434
Operating Weight	kg	4444	4751	5169	5169	5341	5718
WATER HEAT EXCHANGER							
Type *		S&T	S&T	S&T	S&T	S&T	S&T
Water Volume	l	158	158	255	255	255	255
Water flow rate	l/s	20.0	22.6	25.3	27.0	28.7	30.6
Water pressure drop***	kPa	31.2	39.7	36.7	41.1	27.1	30.5
AIR HEAT EXCHANGER							
Type *		MCH	MCH	MCH	MCH	MCH	MCH
FAN							
Type *		DPT	DPT	DPT	DPT	DPT	DPT
Drive *		VFD	VFD	VFD	VFD	VFD	VFD
Diameter	mm	800	800	800	800	800	800
Nominal air flow	l/s	37774	45328	45328	45328	52883	60438
Quantity	No.	10	12	12	12	14	16
Speed	rpm	700	700	700	700	700	700
Motor input	kW	8.0	9.6	9.6	9.6	11.2	12.8
COMPRESSOR							
Oil charge	l	20.0	20.0	20.0	20.0	20.0	20.0
Quantity	No.	2	2	2	2	2	2
SOUND LEVEL**							
Sound Power - Cooling	dB(A)	99	99	99	100	100	101
Sound Pressure level@1m distance - Cooling	dB(A)	79	79	79	79	79	80
REFRIGERANT CIRCUIT							
Refrigerant type		R134a	R134a	R134a	R134a	R134a	R134a
Refrigerant charge	kg	64	74	80	80	89	96
N. of circuits	No.	2	2	2	2	2	2
PIPING CONNECTIONS							
Evaporator water inlet/outlet	mm	139.7	139.7	168.3	168.3	168.3	168.3

All the performances (Cooling capacity, unit power input in cooling and EER) are based on the following conditions: evaporator 12.0/7.0°C; ambient 35.0°C, unit at full load operation; operating fluid: Water; fouling factor = 0.

(*)PHE: Plate Heat Exchanger; S&T: Single Pass Shell & Tube; MCH: Microchannel; DPT: Direct Propeller Type; DOL: Direct On Line - VFD: Inverter - BRS: Brushless

(**) Sound power level (referred to evaporator 12/7°C, ambient 35°C full load operation) are measured in accordance with ISO 9614 and Eurovent 8/1 for Eurovent certified units. The certification refers only to the overall sound power level, the sound pressure is calculated from the sound power level and are for information only and not considered binding. The minimum capacity indicated is referred to unit operating at standard Eurovent conditions. Dimensions and weights are for indication only and not considered binding. Before designing the installation, consult the official drawings available from the factory at request. All the data are referred to standard unit without options. All data are subject to change without notice.

(***) The value refers to the pressure drops in the evaporator only.

(****) In accordance with standard EN14825:2013, comfort low temperature, average climate. SEER and η_s values applicable Ecodesign regulation: (EU) No 2016/2281.

Eurovent certified values

EWAD~TZ-XS B

MODEL		EWAD680TZ -XS B2	EWAD770TZ -XS B2	EWAD850TZ -XS B2	EWAD910TZ -XS B2	EWADC10TZ -XS B2	EWADC11TZ -XS B2
COOLING PERFORMANCE							
Capacity - Cooling	kW	678	764	850	912	1,001	1,045
Capacity control - Type		Stepless	Stepless	Stepless	Stepless	Stepless	Stepless
Capacity control - Minimum capacity	%	13	10	10	10	10	10
Unit power input - Cooling	kW	219	226	266	275	303	320
EER		3.09	3.37	3.20	3.31	3.30	3.27
ESEER		5.09	5.09	5.09	5.13	5.15	5.22
IPLV		6.21	6.26	6.08	6.19	6.29	6.24
SEASONAL ENERGY EFFICIENCY ****							
SEER (12/7°C)		5.21	5.79	5.74	5.91	6.15	6
$\eta_{s\ cool}(12/7°C)$	%	205	229	227	233	243	237
DIMENSIONS							
Height	mm	2540	2540	2540	2540	2540	2540
Width	mm	2282	2282	2282	2282	2282	2282
Length	mm	7684	7787	7787	8687	9587	10488
WEIGHT							
Unit Weight	kg	5434	6178	6310	6652	6930	7258
Operating Weight	kg	5718	6458	6760	7102	7380	7708
WATER HEAT EXCHANGER							
Type *		S&T	S&T	S&T	S&T	S&T	S&T
Water Volume	l	255	301	485	485	485	453
Water flow rate	l/s	32.4	36.6	40.7	43.6	47.9	50.0
Water pressure drop***	kPa	33.3	40.5	33.5	37.5	42.4	34.3
AIR HEAT EXCHANGER							
Type *		MCH	MCH	MCH	MCH	MCH	MCH
FAN							
Type *		DPT	DPT	DPT	DPT	DPT	DPT
Drive *		VFD	VFD	VFD	VFD	VFD	VFD
Diameter	mm	800	800	800	800	800	800
Nominal air flow	l/s	60438	60438	60438	67993	75547	83102
Quantity	No.	16	16	16	18	20	22
Speed	rpm	700	700	700	700	700	700
Motor input	kW	12.8	12.8	12.8	14.4	16.0	17.6
COMPRESSOR							
Oil charge	l	20.0	36.0	36.0	36.0	36.0	36.0
Quantity	No.	2	2	2	2	2	2
SOUND LEVEL**							
Sound Power - Cooling	dB(A)	101	101	101	101	101	102
Sound Pressure level@1m distance - Cooling	dB(A)	80	80	80	79	79	79
REFRIGERANT CIRCUIT							
Refrigerant type		R134a	R134a	R134a	R134a	R134a	R134a
Refrigerant charge	kg	96	104	104	117	130	143
N. of circuits	No.	2	2	2	2	2	2
PIPING CONNECTIONS							
Evaporator water inlet/outlet	mm	168.3	168.3	219.1	219.1	219.1	219.1

All the performances (Cooling capacity, unit power input in cooling and EER) are based on the following conditions: evaporator 12.0/7.0°C; ambient 35.0°C, unit at full load operation; operating fluid: Water; fouling factor = 0.

(*)PHE: Plate Heat Exchanger; S&T: Single Pass Shell & Tube; MCH: Microchannel; DPT: Direct Propeller Type; DOL: Direct On Line - VFD: Inverter - BRS: Brushless

(**) Sound power level (referred to evaporator 12/7°C, ambient 35°C full load operation) are measured in accordance with ISO 9614 and Eurovent 8/1 for Eurovent certified units. The certification refers only to the overall sound power level, the sound pressure is calculated from the sound power level and are for information only and not considered binding. The minimum capacity indicated is referred to unit operating at standard Eurovent conditions. Dimensions and weights are for indication only and not considered binding. Before designing the installation, consult the official drawings available from the factory at request. All the data are referred to standard unit without options. All data are subject to change without notice.

(***) The value refers to the pressure drops in the evaporator only.

(****) In accordance with standard EN14825:2013, comfort low temperature, average climate. SEER and η_s values applicable Ecodesign regulation: (EU) No 2016/2281.

Eurovent certified values

EWAD~TZ-XL B

MODEL		EWAD190TZ -XL B1	EWAD220TZ -XL B1	EWAD240TZ -XL B1	EWAD290TZ -XL B1	EWAD320TZ -XL B1	EWAD360TZ -XL B2
COOLING PERFORMANCE							
Capacity - Cooling	kW	180	211	240	277	313	361
Capacity control - Type		Stepless	Stepless	Stepless	Stepless	Stepless	Stepless
Capacity control - Minimum capacity	%	34	29	34	29	25	17
Unit power input - Cooling	kW	52.1	63.2	72.5	83.9	100	109
EER		3.46	3.34	3.30	3.30	3.13	3.30
ESEER		5.11	5.06	4.99	5.09	5.13	5.14
IPLV		6.26	6.15	6.19	6.17	6.17	6.40
SEASONAL ENERGY EFFICIENCY ****							
SEER (12/7°C)		4.95	5.04	4.96	5.15	5.14	4.96
$\eta_{s\ cool}(12/7^\circ C)$	%	195	199	195	203	203	195
DIMENSIONS							
Height	mm	2540	2540	2540	2540	2540	2540
Width	mm	2282	2282	2282	2282	2282	2282
Length	mm	3231	3231	4131	4131	5030	5030
WEIGHT							
Unit Weight	kg	2411	2411	2411	2784	2784	4281
Operating Weight	kg	2454	2454	2454	2836	2836	4444
WATER HEAT EXCHANGER							
Type *		PHE	PHE	PHE	PHE	PHE	S&T
Water Volume	l	26	37	37	50	50	158
Water flow rate	l/s	8.6	10.1	11.5	13.2	15.0	17.3
Water pressure drop***	kPa	16.4	13.2	16.2	17.1	21.0	34.3
AIR HEAT EXCHANGER							
Type *		MCH	MCH	MCH	MCH	MCH	MCH
FAN							
Type *		DPT	DPT	DPT	DPT	DPT	DPT
Drive *		VFD	VFD	VFD	VFD	VFD	VFD
Diameter	mm	800	800	800	800	800	800
Nominal air flow	l/s	22664	22664	22664	30219	30219	37774
Quantity	No.	6	6	6	8	8	10
Speed	rpm	700	700	700	700	700	700
Motor input	kW	4.8	4.8	4.8	6.4	6.4	8.0
COMPRESSOR							
Oil charge	l	10.0	10.0	10.0	10.0	10.0	20.0
Quantity	No.	1	1	1	1	1	2
SOUND LEVEL**							
Sound Power - Cooling	dB(A)	91	91	91	91	92	93
Sound Pressure level@1m distance - Cooling	dB(A)	72	72	72	72	73	73
REFRIGERANT CIRCUIT							
Refrigerant type		R134a	R134a	R134a	R134a	R134a	R134a
Refrigerant charge	kg	36	39	40	51	51	64
N. of circuits	No.	1	1	1	1	1	2
PIPING CONNECTIONS							
Evaporator water inlet/outlet	mm	88.9	88.9	114.3	114.3	114.3	139.7

All the performances (Cooling capacity, unit power input in cooling and EER) are based on the following conditions: evaporator 12.0/7.0°C; ambient 35.0°C, unit at full load operation; operating fluid: Water; fouling factor = 0.

(*)PHE: Plate Heat Exchanger; S&T: Single Pass Shell & Tube; MCH: Microchannel; DPT: Direct Propeller Type; DOL: Direct On Line - VFD: Inverter - BRS: Brushless

(**) Sound power level (referred to evaporator 12/7°C, ambient 35°C full load operation) are measured in accordance with ISO 9614 and Eurovent 8/1 for Eurovent certified units. The certification refers only to the overall sound power level, the sound pressure is calculated from the sound power level and are for information only and not considered binding. The minimum capacity indicated is referred to unit operating at standard Eurovent conditions. Dimensions and weights are for indication only and not considered binding. Before designing the installation, consult the official drawings available from the factory at request. All the data are referred to standard unit without options. All data are subject to change without notice.

(***) The value refers to the pressure drops in the evaporator only.

(****) In accordance with standard EN14825:2013, comfort low temperature, average climate. SEER and η_s values applicable Ecodesign regulation: (EU) No 2016/2281.

EWAD~TZ-XL B

MODEL		EWAD420TZ -XL B2	EWAD450TZ -XL B2	EWAD540TZ -XL B2	EWAD570TZ -XL B2	EWAD610TZ -XL B2	EWAD660TZ -XL B2
COOLING PERFORMANCE							
Capacity - Cooling	kW	417	473	529	563	599	639
Capacity control - Type		Stepless	Stepless	Stepless	Stepless	Stepless	Stepless
Capacity control - Minimum capacity	%	16	17	16	15	14	13
Unit power input - Cooling	kW	132	144	163	181	191	202
EER		3.16	3.26	3.24	3.11	3.13	3.16
ESEER		5.09	5.00	5.07	5.07	5.11	5.15
IPLV		6.30	6.22	6.22	6.29	6.31	6.25
SEASONAL ENERGY EFFICIENCY ****							
SEER (12/7°C)		5.03	5.07	5.1	5.04	5.17	5.23
$\eta_{s\ cool}(12/7°C)$	%	198	200	201	199	204	206
DIMENSIONS							
Height	mm	2540	2540	2540	2540	2540	2540
Width	mm	2282	2282	2282	2282	2282	2282
Length	mm	5030	5887	5887	5887	6786	7684
WEIGHT							
Unit Weight	kg	4281	4588	4907	4907	5078	5434
Operating Weight	kg	4444	4751	5169	5169	5341	5718
WATER HEAT EXCHANGER							
Type *		S&T	S&T	S&T	S&T	S&T	S&T
Water Volume	l	158	158	255	255	255	255
Water flow rate	l/s	20.0	22.6	25.3	27.0	28.7	30.6
Water pressure drop***	kPa	31.2	39.7	36.7	41.1	27.1	30.5
AIR HEAT EXCHANGER							
Type *		MCH	MCH	MCH	MCH	MCH	MCH
FAN							
Type *		DPT	DPT	DPT	DPT	DPT	DPT
Drive *		VFD	VFD	VFD	VFD	VFD	VFD
Diameter	mm	800	800	800	800	800	800
Nominal air flow	l/s	37774	45328	45328	45328	52883	60438
Quantity	No.	10	12	12	12	14	16
Speed	rpm	700	700	700	700	700	700
Motor input	kW	8.0	9.6	9.6	9.6	11.2	12.8
COMPRESSOR							
Oil charge	l	20.0	20.0	20.0	20.0	20.0	20.0
Quantity	No.	2	2	2	2	2	2
SOUND LEVEL **							
Sound Power - Cooling	dB(A)	94	94	94	94	95	95
Sound Pressure level@1m distance - Cooling	dB(A)	74	73	73	74	74	74
REFRIGERANT CIRCUIT							
Refrigerant type		R134a	R134a	R134a	R134a	R134a	R134a
Refrigerant charge	kg	64	74	80	80	89	96
N. of circuits	No.	2	2	2	2	2	2
PIPING CONNECTIONS							
Evaporator water inlet/outlet	mm	139.7	139.7	168.3	168.3	168.3	168.3

All the performances (Cooling capacity, unit power input in cooling and EER) are based on the following conditions: evaporator 12.0/7.0°C; ambient 35.0°C, unit at full load operation; operating fluid: Water; fouling factor = 0.

(*)PHE: Plate Heat Exchanger; S&T: Single Pass Shell & Tube; MCH: Microchannel; DPT: Direct Propeller Type; DOL: Direct On Line - VFD: Inverter - BRS: Brushless

(**) Sound power level (referred to evaporator 12/7°C, ambient 35°C full load operation) are measured in accordance with ISO 9614 and Eurovent 8/1 for Eurovent certified units. The certification refers only to the overall sound power level, the sound pressure is calculated from the sound power level and are for information only and not considered binding. The minimum capacity indicated is referred to unit operating at standard Eurovent conditions. Dimensions and weights are for indication only and not considered binding. Before designing the installation, consult the official drawings available from the factory at request. All the data are referred to standard unit without options. All data are subject to change without notice.

(***) The value refers to the pressure drops in the evaporator only.

(****) In accordance with standard EN14825:2013, comfort low temperature, average climate. SEER and η_s values applicable Ecodesign regulation: (EU) No 2016/2281.

Eurovent certified values

EWAD~TZ-XL B

MODEL		EWAD680TZ -XL B2	EWAD770TZ -XL B2	EWAD850TZ -XL B2	EWAD910TZ -XL B2	EWADC10TZ -XL B2	EWADC11TZ -XL B2
COOLING PERFORMANCE							
Capacity - Cooling	kW	678	764	850	912	1,001	1,045
Capacity control - Type		Stepless	Stepless	Stepless	Stepless	Stepless	Stepless
Capacity control - Minimum capacity	%	13	10	10	10	10	10
Unit power input - Cooling	kW	219	226	266	275	303	320
EER		3.09	3.37	3.20	3.31	3.30	3.27
ESEER		5.09	5.09	5.09	5.13	5.15	5.22
IPLV		6.21	6.26	6.08	6.19	6.29	6.24
SEASONAL ENERGY EFFICIENCY ****							
SEER (12/7°C)		5.21	5.79	5.74	5.91	6.15	6
$\eta_{s\ cool}(12/7°C)$	%	205	229	227	233	243	237
DIMENSIONS							
Height	mm	2540	2540	2540	2540	2540	2540
Width	mm	2282	2282	2282	2282	2282	2282
Length	mm	7684	7787	7787	8687	9587	10488
WEIGHT							
Unit Weight	kg	5434	6178	6310	6652	6930	7258
Operating Weight	kg	5718	6458	6760	7102	7380	7708
WATER HEAT EXCHANGER							
Type *		S&T	S&T	S&T	S&T	S&T	S&T
Water Volume	l	255	301	485	485	485	453
Water flow rate	l/s	32.4	36.6	40.7	43.6	47.9	50.0
Water pressure drop***	kPa	33.3	40.5	33.5	37.5	42.4	34.3
AIR HEAT EXCHANGER							
Type *		MCH	MCH	MCH	MCH	MCH	MCH
FAN							
Type *		DPT	DPT	DPT	DPT	DPT	DPT
Drive *		VFD	VFD	VFD	VFD	VFD	VFD
Diameter	mm	800	800	800	800	800	800
Nominal air flow	l/s	60438	60438	60438	67993	75547	83102
Quantity	No.	16	16	16	18	20	22
Speed	rpm	700	700	700	700	700	700
Motor input	kW	12.8	12.8	12.8	14.4	16.0	17.6
COMPRESSOR							
Oil charge	l	20.0	36.0	36.0	36.0	36.0	36.0
Quantity	No.	2	2	2	2	2	2
SOUND LEVEL **							
Sound Power - Cooling	dB(A)	95	97	97	97	97	97
Sound Pressure level@1m distance - Cooling	dB(A)	74	75	75	75	75	75
REFRIGERANT CIRCUIT							
Refrigerant type		R134a	R134a	R134a	R134a	R134a	R134a
Refrigerant charge	kg	96	104	104	117	130	143
N. of circuits	No.	2	2	2	2	2	2
PIPING CONNECTIONS							
Evaporator water inlet/outlet	mm	168.3	168.3	219.1	219.1	219.1	219.1

All the performances (Cooling capacity, unit power input in cooling and EER) are based on the following conditions: evaporator 12.0/7.0°C; ambient 35.0°C, unit at full load operation; operating fluid: Water; fouling factor = 0.

(*)PHE: Plate Heat Exchanger; S&T: Single Pass Shell & Tube; MCH: Microchannel; DPT: Direct Propeller Type; DOL: Direct On Line - VFD: Inverter - BRS: Brushless

(**) Sound power level (referred to evaporator 12/7°C, ambient 35°C full load operation) are measured in accordance with ISO 9614 and Eurovent 8/1 for Eurovent certified units. The certification refers only to the overall sound power level, the sound pressure is calculated from the sound power level and are for information only and not considered binding. The minimum capacity indicated is referred to unit operating at standard Eurovent conditions. Dimensions and weights are for indication only and not considered binding. Before designing the installation, consult the official drawings available from the factory at request. All the data are referred to standard unit without options. All data are subject to change without notice.

(***) The value refers to the pressure drops in the evaporator only.

(****) In accordance with standard EN14825:2013, comfort low temperature, average climate. SEER and η_s values applicable Ecodesign regulation: (EU) No 2016/2281.

Eurovent certified values

EWAD~TZ-XR B

MODEL		EWAD190TZ -XR B1	EWAD220TZ -XR B1	EWAD240TZ -XR B1	EWAD290TZ -XR B1	EWAD320TZ -XR B1	EWAD360TZ -XR B2
COOLING PERFORMANCE							
Capacity - Cooling	kW	180	211	240	277	313	360
Capacity control - Type		Stepless	Stepless	Stepless	Stepless	Stepless	Stepless
Capacity control - Minimum capacity	%	34	29	34	29	25	17
Unit power input - Cooling	kW	52.1	63.2	72.5	83.9	100	109
EER		3.46	3.34	3.30	3.30	3.13	3.29
ESEER		5.11	5.06	4.99	5.09	5.13	5.12
IPLV		6.26	6.15	6.19	6.17	6.17	6.37
SEASONAL ENERGY EFFICIENCY ****							
SEER (12/7°C)		4.95	5.04	4.96	5.15	5.14	4.94
$\eta_{s\ cool}(12/7^\circ C)$	%	195	199	195	203	203	195
DIMENSIONS							
Height	mm	2540	2540	2540	2540	2540	2540
Width	mm	2282	2282	2282	2282	2282	2282
Length	mm	3231	3231	4131	4131	5030	5030
WEIGHT							
Unit Weight	kg	2411	2411	2411	2784	2784	4281
Operating Weight	kg	2454	2454	2454	2836	2836	4444
WATER HEAT EXCHANGER							
Type *		PHE	PHE	PHE	PHE	PHE	S&T
Water Volume	l	26	37	37	50	50	158
Water flow rate	l/s	8.6	10.1	11.5	13.2	15.0	17.2
Water pressure drop***	kPa	16.4	13.2	16.2	17.1	21.0	34.2
AIR HEAT EXCHANGER							
Type *		MCH	MCH	MCH	MCH	MCH	MCH
FAN							
Type *		DPT	DPT	DPT	DPT	DPT	DPT
Drive *		VFD	VFD	VFD	VFD	VFD	VFD
Diameter	mm	800	800	800	800	800	800
Nominal air flow	l/s	22664	22664	22664	30219	30219	36920
Quantity	No.	6	6	6	8	8	10
Speed	rpm	700	700	700	700	700	700
Motor input	kW	4.8	4.8	4.8	6.4	6.4	8.0
COMPRESSOR							
Oil charge	l	10.0	10.0	10.0	10.0	10.0	20.0
Quantity	No.	1	1	1	1	1	2
SOUND LEVEL**							
Sound Power - Cooling	dB(A)	88	88	88	89	89	90
Sound Pressure level@1m distance - Cooling	dB(A)	68	68	68	69	69	70
REFRIGERANT CIRCUIT							
Refrigerant type		R134a	R134a	R134a	R134a	R134a	R134a
Refrigerant charge	kg	36	39	40	51	51	64
N. of circuits	No.	1	1	1	1	1	2
PIPING CONNECTIONS							
Evaporator water inlet/outlet	mm	88.9	88.9	114.3	114.3	114.3	139.7

All the performances (Cooling capacity, unit power input in cooling and EER) are based on the following conditions: evaporator 12.0/7.0°C; ambient 35.0°C, unit at full load operation; operating fluid: Water; fouling factor = 0.

(*PHE: Plate Heat Exchanger; S&T: Single Pass Shell & Tube; MCH: Microchannel; DPT: Direct Propeller Type; DOL: Direct On Line - VFD: Inverter - BRS: Brushless

(**) Sound power level (referred to evaporator 12/7°C, ambient 35°C full load operation) are measured in accordance with ISO 9614 and Eurovent 8/1 for Eurovent certified units. The certification refers only to the overall sound power level, the sound pressure is calculated from the sound power level and are for information only and not considered binding. The minimum capacity indicated is referred to unit operating at standard Eurovent conditions. Dimensions and weights are for indication only and not considered binding. Before designing the installation, consult the official drawings available from the factory at request. All the data are referred to standard unit without options. All data are subject to change without notice.

(***) The value refers to the pressure drops in the evaporator only.

(****) In accordance with standard EN14825:2013, comfort low temperature, average climate. SEER and η_s values applicable Ecodesign regulation: (EU) No 2016/2281.

Eurovent certified values

EWAD~TZ-XR B

MODEL		EWAD420TZ -XR B2	EWAD450TZ -XR B2	EWAD540TZ -XR B2	EWAD570TZ -XR B2	EWAD610TZ -XR B2	EWAD660TZ -XR B2
COOLING PERFORMANCE							
Capacity - Cooling	kW	417	472	528	562	599	639
Capacity control - Type		Stepless	Stepless	Stepless	Stepless	Stepless	Stepless
Capacity control - Minimum capacity	%	16	17	16	15	14	13
Unit power input - Cooling	kW	132	145	164	181	192	203
EER		3.16	3.24	3.22	3.09	3.11	3.15
ESEER		5.09	4.99	5.04	5.05	5.13	5.13
IPLV		6.30	6.20	6.20	6.26	6.27	6.24
SEASONAL ENERGY EFFICIENCY ****							
SEER (12/7°C)		5.03	5.05	5.08	5.03	5.14	5.2
$\eta_{s\ cool}(12/7^\circ C)$	%	198	199	200	198	203	205
DIMENSIONS							
Height	mm	2540	2540	2540	2540	2540	2540
Width	mm	2282	2282	2282	2282	2282	2282
Length	mm	5030	5887	5887	5887	6786	7684
WEIGHT							
Unit Weight	kg	4281	4588	4907	4907	5078	5434
Operating Weight	kg	4444	4751	5169	5169	5341	5718
WATER HEAT EXCHANGER							
Type *		S&T	S&T	S&T	S&T	S&T	S&T
Water Volume	l	158	158	255	255	255	255
Water flow rate	l/s	20.0	22.6	25.3	26.9	28.6	30.5
Water pressure drop***	kPa	31.2	39.7	36.6	41.0	27.1	30.4
AIR HEAT EXCHANGER							
Type *		MCH	MCH	MCH	MCH	MCH	MCH
FAN							
Type *		DPT	DPT	DPT	DPT	DPT	DPT
Drive *		VFD	VFD	VFD	VFD	VFD	VFD
Diameter	mm	800	800	800	800	800	800
Nominal air flow	l/s	37774	44475	44475	44475	51745	59299
Quantity	No.	10	12	12	12	14	16
Speed	rpm	700	700	700	700	700	700
Motor input	kW	8.0	9.6	9.6	9.6	11.2	12.8
COMPRESSOR							
Oil charge	l	20.0	20.0	20.0	20.0	20.0	20.0
Quantity	No.	2	2	2	2	2	2
SOUND LEVEL**							
Sound Power - Cooling	dB(A)	90	91	91	91	91	92
Sound Pressure level@1m distance - Cooling	dB(A)	70	70	70	70	70	71
REFRIGERANT CIRCUIT							
Refrigerant type		R134a	R134a	R134a	R134a	R134a	R134a
Refrigerant charge	kg	64	74	80	80	89	96
N. of circuits	No.	2	2	2	2	2	2
PIPING CONNECTIONS							
Evaporator water inlet/outlet	mm	139.7	139.7	168.3	168.3	168.3	168.3

All the performances (Cooling capacity, unit power input in cooling and EER) are based on the following conditions: evaporator 12.0/7.0°C; ambient 35.0°C, unit at full load operation; operating fluid: Water; fouling factor = 0.

(*PHE: Plate Heat Exchanger; S&T: Single Pass Shell & Tube; MCH: Microchannel; DPT: Direct Propeller Type; DOL: Direct On Line - VFD: Inverter - BRS: Brushless

(**) Sound power level (referred to evaporator 12/7°C, ambient 35°C full load operation) are measured in accordance with ISO 9614 and Eurovent 8/1 for Eurovent certified units. The certification refers only to the overall sound power level, the sound pressure is calculated from the sound power level and are for information only and not considered binding. The minimum capacity indicated is referred to unit operating at standard Eurovent conditions. Dimensions and weights are for indication only and not considered binding. Before designing the installation, consult the official drawings available from the factory at request. All the data are referred to standard unit without options. All data are subject to change without notice.

(***) The value refers to the pressure drops in the evaporator only.

(****) In accordance with standard EN14825:2013, comfort low temperature, average climate. SEER and η_s values applicable Ecodesign regulation: (EU) No 2016/2281.

Eurovent certified values

EWAD~TZ-XR B

MODEL		EWAD680TZ -XR B2	EWAD770TZ -XR B2	EWAD850TZ -XR B2	EWAD910TZ -XR B2	EWADC10TZ -XR B2	EWADC11TZ -XR B2
COOLING PERFORMANCE							
Capacity - Cooling	kW	677	764	850	912	1,001	1,045
Capacity control - Type		Stepless	Stepless	Stepless	Stepless	Stepless	Stepless
Capacity control - Minimum capacity	%	13	10	10	10	10	10
Unit power input - Cooling	kW	220	226	266	275	303	320
EER		3.07	3.37	3.19	3.31	3.30	3.26
ESEER		5.07	5.09	5.09	5.13	5.15	5.22
IPLV		6.18	6.26	6.08	6.19	6.29	6.24
SEASONAL ENERGY EFFICIENCY ****							
SEER (12/7°C)		5.19	5.82	5.81	5.91	6.18	6.02
$\eta_{s\ cool}(12/7°C)$	%	205	230	229	233	244	238
DIMENSIONS							
Height	mm	2540	2540	2540	2540	2540	2540
Width	mm	2282	2282	2282	2282	2282	2282
Length	mm	7684	7787	7787	8687	9587	10488
WEIGHT							
Unit Weight	kg	5434	6178	6310	6652	6930	7258
Operating Weight	kg	5718	6458	6760	7102	7380	7708
WATER HEAT EXCHANGER							
Type *		S&T	S&T	S&T	S&T	S&T	S&T
Water Volume	l	255	301	485	485	485	453
Water flow rate	l/s	32.4	36.6	40.7	43.6	47.9	50.0
Water pressure drop***	kPa	33.2	40.3	33.3	37.3	42.3	34.2
Insulation material *		CC	CC	CC	CC	CC	CC
AIR HEAT EXCHANGER							
Type *		MCH	MCH	MCH	MCH	MCH	MCH
FAN							
Type *		DPT	DPT	DPT	DPT	DPT	DPT
Drive *		VFD	VFD	VFD	VFD	VFD	VFD
Diameter	mm	800	800	800	800	800	800
Nominal air flow	l/s	59299	59299	59299	66570	74124	81394
Quantity	No.	16	16	16	18	20	22
Speed	rpm	700	700	700	700	700	700
Motor input	kW	12.8	12.8	12.8	14.4	16.0	17.6
COMPRESSOR							
Oil charge	l	20.0	36.0	36.0	36.0	36.0	36.0
Quantity	No.	2	2	2	2	2	2
SOUND LEVEL **							
Sound Power - Cooling	dB(A)	92	94	94	95	95	95
Sound Pressure level@1m distance - Cooling	dB(A)	71	73	73	73	73	73
REFRIGERANT CIRCUIT							
Refrigerant type		R134a	R134a	R134a	R134a	R134a	R134a
Refrigerant charge	kg	96	104	104	117	130	143
N. of circuits	No.	2	2	2	2	2	2
PIPING CONNECTIONS							
Evaporator water inlet/outlet	mm	168.3	168.3	219.1	219.1	219.1	219.1

All the performances (Cooling capacity, unit power input in cooling and EER) are based on the following conditions: evaporator 12.0/7.0°C; ambient 35.0°C, unit at full load operation; operating fluid: Water; fouling factor = 0.

(*)PHE: Plate Heat Exchanger; S&T: Single Pass Shell & Tube; MCH: Microchannel; DPT: Direct Propeller Type; DOL: Direct On Line - VFD: Inverter - BRS: Brushless

(**) Sound power level (referred to evaporator 12/7°C, ambient 35°C full load operation) are measured in accordance with ISO 9614 and Eurovent 8/1 for Eurovent certified units. The certification refers only to the overall sound power level, the sound pressure is calculated from the sound power level and are for information only and not considered binding. The minimum capacity indicated is referred to unit operating at standard Eurovent conditions. Dimensions and weights are for indication only and not considered binding. Before designing the installation, consult the official drawings available from the factory at request. All the data are referred to standard unit without options. All data are subject to change without notice.

(***) The value refers to the pressure drops in the evaporator only. (****) In accordance with standard EN14825:2013, comfort low temperature, average climate. SEER and η_s values applicable Ecodesign regulation: (EU) No 2016/2281.

Eurovent certified values

EWAD~TZ-PS B

MODEL		EWAD190TZ -PS B1	EWAD220TZ -PS B1	EWAD240TZ -PS B1	EWAD290TZ -PS B1	EWAD300TZ -PS B1	EWAD350TZ -PS B2
COOLING PERFORMANCE							
Capacity - Cooling	kW	184	216	244	282	323	379
Capacity control - Type		Stepless	Stepless	Stepless	Stepless	Stepless	Stepless
Capacity control - Minimum capacity	%	34	29	34	29	27	19
Unit power input - Cooling	kW	50.5	60.7	68.7	83.4	95.9	104
EER		3.64	3.56	3.55	3.38	3.37	3.62
ESEER		5.54	5.51	5.42	5.40	5.35	5.48
IPLV		6.49	6.35	6.41	6.35	6.21	6.52
SEASONAL ENERGY EFFICIENCY ****							
SEER (12/7°C)		5.19	5.33	5.29	5.3	5.5	5.25
$\eta_{s\ cool}(12/7^\circ C)$	%	205	210	209	209	217	207
DIMENSIONS							
Height	mm	2540	2540	2540	2540	2540	2540
Width	mm	2282	2282	2282	2282	2282	2282
Length	mm	4131	4131	4131	4131	5030	5887
WEIGHT							
Unit Weight	kg	2784	2784	2784	2784	3055	4907
Operating Weight	kg	2836	2836	2836	2836	3106	5169
WATER HEAT EXCHANGER							
Type *		PHE	PHE	PHE	PHE	PHE	S&T
Water Volume	l	50	50	50	50	50	255
Water flow rate	l/s	8.8	10.3	11.7	13.5	15.5	18.1
Water pressure drop***	kPa	10.6	11.0	13.4	17.1	21.5	20.4
AIR HEAT EXCHANGER							
Type *		MCH	MCH	MCH	MCH	MCH	MCH
FAN							
Type *		DPT	DPT	DPT	DPT	DPT	DPT
Drive *		BRS	BRS	BRS	BRS	BRS	BRS
Diameter	mm	800	800	800	800	800	800
Nominal air flow	l/s	29610	29610	29610	29610	37013	44415
Quantity	No.	8	8	8	8	10	12
Speed	rpm	700	700	700	700	700	700
Motor input	kW	5.6	5.6	5.6	5.6	7.0	8.4
COMPRESSOR							
Oil charge	l	10.0	10.0	10.0	10.0	10.0	20.0
Quantity	No.	1	1	1	1	1	2
SOUND LEVEL**							
Sound Power - Cooling	dB(A)	97	97	97	97	98	99
Sound Pressure level@1m distance - Cooling	dB(A)	77	77	77	77	77	78
REFRIGERANT CIRCUIT							
Refrigerant type		R134a	R134a	R134a	R134a	R134a	R134a
Refrigerant charge	kg	49	49	50	51	58	77
N. of circuits	No.	1	1	1	1	1	2
PIPING CONNECTIONS							
Evaporator water inlet/outlet	mm	88.9	88.9	114.3	114.3	114.3	168.3

All the performances (Cooling capacity, unit power input in cooling and EER) are based on the following conditions: evaporator 12.0/7.0°C; ambient 35.0°C, unit at full load operation; operating fluid: Water; fouling factor = 0.

(*)PHE: Plate Heat Exchanger; S&T: Single Pass Shell & Tube; MCH: Microchannel; DPT: Direct Propeller Type; DOL: Direct On Line - VFD: Inverter - BRS: Brushless

(**) Sound power level (referred to evaporator 12/7°C, ambient 35°C full load operation) are measured in accordance with ISO 9614 and Eurovent 8/1 for Eurovent certified units. The certification refers only to the overall sound power level, the sound pressure is calculated from the sound power level and are for information only and not considered binding. The minimum capacity indicated is referred to unit operating at standard Eurovent conditions. Dimensions and weights are for indication only and not considered binding. Before designing the installation, consult the official drawings available from the factory at request. All the data are referred to standard unit without options. All data are subject to change without notice.

(***) The value refers to the pressure drops in the evaporator only.

(****) In accordance with standard EN14825:2013, comfort low temperature, average climate. SEER and η_s values applicable Ecodesign regulation: (EU) No 2016/2281.

EWAD~TZ-PS B

MODEL		EWAD420TZ -PS B2	EWAD495TZ -PS B2	EWAD550TZ -PS B2	EWAD620TZ -PS B2	EWAD720TZ -PS B2	EWAD820TZ -PS B2
COOLING PERFORMANCE							
Capacity - Cooling	kW	437	501	543	620	717	833
Capacity control - Type		Stepless	Stepless	Stepless	Stepless	Stepless	Stepless
Capacity control - Minimum capacity	%	20	17	10	10	10	10
Unit power input - Cooling	kW	124	139	151	178	182	220
EER		3.50	3.60	3.59	3.47	3.93	3.78
ESEER		5.48	5.45	5.50	5.42	5.59	5.54
IPLV		6.58	6.55	6.51	6.47	6.73	6.60
SEASONAL ENERGY EFFICIENCY ****							
SEER (12/7°C)		5.36	5.62	5.55	6.11	6.22	6.3
$\eta_{s\ cool}(12/7°C)$	%	211	222	219	241	246	249
DIMENSIONS							
Height	mm	2540	2540	2540	2540	2540	2540
Width	mm	2282	2282	2282	2282	2282	2282
Length	mm	6786	7684	8579	9480	9587	10488
WEIGHT							
Unit Weight	kg	5078	5434	6212	6532	6930	7258
Operating Weight	kg	5341	5718	6522	6830	7380	7708
WATER HEAT EXCHANGER							
Type *		S&T	S&T	S&T	S&T	S&T	S&T
Water Volume	l	255	255	307	307	485	485
Water flow rate	l/s	20.9	24.0	26.0	29.6	34.3	39.8
Water pressure drop***	kPa	26.5	33.3	19.8	25.0	24.2	31.7
AIR HEAT EXCHANGER							
Type *		MCH	MCH	MCH	MCH	MCH	MCH
FAN							
Type *		DPT	DPT	DPT	DPT	DPT	DPT
Drive *		BRS	BRS	VFD	VFD	BRS	BRS
Diameter	mm	800	800	800	800	800	800
Nominal air flow	l/s	51818	59220	66623	74025	74025	81428
Quantity	No.	14	16	18	20	20	22
Speed	rpm	700	700	700	700	700	700
Motor input	kW	9.8	11.2	12.6	14.0	14.0	15.4
COMPRESSOR							
Oil charge	l	20.0	20.0	26.0	26.0	36.0	36.0
Quantity	No.	2	2	2	2	2	2
SOUND LEVEL **							
Sound Power - Cooling	dB(A)	99	100	101	101	101	101
Sound Pressure level@1m distance - Cooling	dB(A)	77	78	79	79	79	79
REFRIGERANT CIRCUIT							
Refrigerant type		R134a	R134a	R134a	R134a	R134a	R134a
Refrigerant charge	kg	86	94	105	114	130	143
N. of circuits	No.	2	2	2	2	2	2
PIPING CONNECTIONS							
Evaporator water inlet/outlet	mm	168.3	168.3	168.3	168.3	219.1	219.1

All the performances (Cooling capacity, unit power input in cooling and EER) are based on the following conditions: evaporator 12.0/7.0°C; ambient 35.0°C, unit at full load operation; operating fluid: Water; fouling factor = 0.

(*)PHE: Plate Heat Exchanger; S&T: Single Pass Shell & Tube; MCH: Microchannel; DPT: Direct Propeller Type; DOL: Direct On Line - VFD: Inverter - BRS: Brushless

(**) Sound power level (referred to evaporator 12/7°C, ambient 35°C full load operation) are measured in accordance with ISO 9614 and Eurovent 8/1 for Eurovent certified units. The certification refers only to the overall sound power level, the sound pressure is calculated from the sound power level and are for information only and not considered binding. The minimum capacity indicated is referred to unit operating at standard Eurovent conditions. Dimensions and weights are for indication only and not considered binding. Before designing the installation, consult the official drawings available from the factory at request. All the data are referred to standard unit without options. All data are subject to change without notice.

(***) The value refers to the pressure drops in the evaporator only.

(****) In accordance with standard EN14825:2013, comfort low temperature, average climate. SEER and η_s values applicable Ecodesign regulation: (EU) No 2016/2281.

Eurovent certified values

EWAD~TZ-PS B

MODEL		EWAD950TZ -PS B2
COOLING PERFORMANCE		
Capacity - Cooling	kW	950
Capacity control - Type		Stepless
Capacity control - Minimum capacity	%	10
Unit power input - Cooling	kW	252
EER		3.76
ESEER		5.55
IPLV		6.64
SEASONAL ENERGY EFFICIENCY ****		
SEER (12/7°C)		6.31
$\eta_{S\ cool}(12/7^\circ C)$	%	249
DIMENSIONS		
Height	mm	2540
Width	mm	2282
Length	mm	11387
WEIGHT		
Unit Weight	kg	7550
Operating Weight	kg	8000
WATER HEAT EXCHANGER		
Type *		S&T
Water Volume	l	453
Water flow rate	l/s	45.4
Water pressure drop***	kPa	29.0
AIR HEAT EXCHANGER		
Type *		MCH
FAN		
Type *		DPT
Drive *		BRS
Diameter	mm	800
Nominal air flow	l/s	88830
Quantity	No.	24
Speed	rpm	700
Motor input	kW	16.8
COMPRESSOR		
Oil charge	l	36.0
Quantity	No.	2
SOUND LEVEL**		
Sound Power - Cooling	dB(A)	101
Sound Pressure level@1m distance - Cooling	dB(A)	79
REFRIGERANT CIRCUIT		
Refrigerant type		R134a
Refrigerant charge	kg	156
N. of circuits	No.	2
PIPING CONNECTIONS		
Evaporator water inlet/outlet	mm	219.1

All the performances (Cooling capacity, unit power input in cooling and EER) are based on the following conditions: evaporator 12.0/7.0°C; ambient 35.0°C, unit at full load operation; operating fluid: Water; fouling factor = 0.

(*)PHE: Plate Heat Exchanger; S&T: Single Pass Shell & Tube; MCH: Microchannel; DPT: Direct Propeller Type; DOL: Direct On Line - VFD: Inverter - BRS: Brushless

(**) Sound power level (referred to evaporator 12/7°C, ambient 35°C full load operation) are measured in accordance with ISO 9614 and Eurovent 8/1 for Eurovent certified units. The certification refers only to the overall sound power level, the sound pressure is calculated from the sound power level and are for information only and not considered binding. The minimum capacity indicated is referred to unit operating at standard Eurovent conditions. Dimensions and weights are for indication only and not considered binding. Before designing the installation, consult the official drawings available from the factory at request. All the data are referred to standard unit without options. All data are subject to change without notice.

(***) The value refers to the pressure drops in the evaporator only.

(****) In accordance with standard EN14825:2013, comfort low temperature, average climate. SEER and η_s values applicable Ecodesign regulation: (EU) No 2016/2281.

Eurovent certified values

EWAD~TZ-PL B

MODEL		EWAD190TZ -PL B1	EWAD220TZ -PL B1	EWAD240TZ -PL B1	EWAD290TZ -PL B1	EWAD300TZ -PL B1	EWAD350TZ -PL B2
COOLING PERFORMANCE							
Capacity - Cooling	kW	184	216	244	282	323	379
Capacity control - Type		Stepless	Stepless	Stepless	Stepless	Stepless	Stepless
Capacity control - Minimum capacity	%	34	29	34	29	27	19
Unit power input - Cooling	kW	50.5	60.7	68.7	83.4	95.9	104
EER		3.64	3.56	3.55	3.38	3.37	3.62
ESEER		5.54	5.51	5.42	5.40	5.35	5.48
IPLV		6.49	6.35	6.41	6.35	6.21	6.52
SEASONAL ENERGY EFFICIENCY ****							
SEER (12/7°C)		5.19	5.33	5.29	5.3	5.5	5.25
$\eta_{s\ cool}(12/7°C)$	%	205	210	209	209	217	207
DIMENSIONS							
Height	mm	2540	2540	2540	2540	2540	2540
Width	mm	2282	2282	2282	2282	2282	2282
Length	mm	4131	4131	4131	4131	5030	5887
WEIGHT							
Unit Weight	kg	2784	2784	2784	2784	3055	4907
Operating Weight	kg	2836	2836	2836	2836	3106	5169
WATER HEAT EXCHANGER							
Type *		PHE	PHE	PHE	PHE	PHE	S&T
Water Volume	l	50	50	50	50	50	255
Water flow rate	l/s	8.8	10.3	11.7	13.5	15.5	18.1
Water pressure drop***	kPa	10.6	11.0	13.4	17.1	21.5	20.4
Insulation material *		CC	CC	CC	CC	CC	CC
AIR HEAT EXCHANGER							
Type *		MCH	MCH	MCH	MCH	MCH	MCH
FAN							
Type *		DPT	DPT	DPT	DPT	DPT	DPT
Drive *		BRS	BRS	BRS	BRS	BRS	BRS
Diameter	mm	800	800	800	800	800	800
Nominal air flow	l/s	29610	29610	29610	29610	37013	44415
Quantity	No.	8	8	8	8	10	12
Speed	rpm	700	700	700	700	700	700
Motor input	kW	5.6	5.6	5.6	5.6	7.0	8.4
COMPRESSOR							
Oil charge	l	10.0	10.0	10.0	10.0	10.0	20.0
Quantity	No.	1	1	1	1	1	2
SOUND LEVEL**							
Sound Power - Cooling	dB(A)	91	91	91	91	92	93
Sound Pressure level@1m distance - Cooling	dB(A)	71	72	71	72	72	73
REFRIGERANT CIRCUIT							
Refrigerant type		R134a	R134a	R134a	R134a	R134a	R134a
Refrigerant charge	kg	49	49	50	51	58	77
N. of circuits	No.	1	1	1	1	1	2
PIPING CONNECTIONS							
Evaporator water inlet/outlet	mm	88.9	88.9	114.3	114.3	114.3	168.3

All the performances (Cooling capacity, unit power input in cooling and EER) are based on the following conditions: evaporator 12.0/7.0°C; ambient 35.0°C, unit at full load operation; operating fluid: Water; fouling factor = 0.

(*)PHE: Plate Heat Exchanger; S&T: Single Pass Shell & Tube; MCH: Microchannel; DPT: Direct Propeller Type; DOL: Direct On Line - VFD: Inverter - BRS: Brushless

(**) Sound power level (referred to evaporator 12/7°C, ambient 35°C full load operation) are measured in accordance with ISO 9614 and Eurovent 8/1 for Eurovent certified units. The certification refers only to the overall sound power level, the sound pressure is calculated from the sound power level and are for information only and not considered binding. The minimum capacity indicated is referred to unit operating at standard Eurovent conditions. Dimensions and weights are for indication only and not considered binding. Before designing the installation, consult the official drawings available from the factory at request. All the data are referred to standard unit without options. All data are subject to change without notice.

(***) The value refers to the pressure drops in the evaporator only.

(****) In accordance with standard EN14825:2013, comfort low temperature, average climate. SEER and η_s values applicable Ecodesign regulation: (EU) No 2016/2281.

Eurovent certified values

EWAD~TZ-PL B

MODEL		EWAD420TZ -PL B2	EWAD495TZ -PL B2	EWAD550TZ -PL B2	EWAD620TZ -PL B2	EWAD720TZ -PL B2	EWAD820TZ -PL B2
COOLING PERFORMANCE							
Capacity - Cooling	kW	437	501	543	620	717	833
Capacity control - Type		Stepless	Stepless	Stepless	Stepless	Stepless	Stepless
Capacity control - Minimum capacity	%	20	17	10	10	10	10
Unit power input - Cooling	kW	124	139	151	178	182	220
EER		3.50	3.60	3.59	3.47	3.93	3.78
ESEER		5.49	5.45	5.50	5.42	5.59	5.54
IPLV		6.58	6.55	6.51	6.47	6.73	6.60
SEASONAL ENERGY EFFICIENCY ****							
SEER (12/7°C)		5.36	5.62	5.55	6.11	6.22	6.3
$\eta_{s\ cool}(12/7°C)$	%	211	222	219	241	246	249
DIMENSIONS							
Height	mm	2540	2540	2540	2540	2540	2540
Width	mm	2282	2282	2282	2282	2282	2282
Length	mm	6786	7684	8579	9480	9587	10488
WEIGHT							
Unit Weight	kg	5078	5434	6212	6532	6930	7258
Operating Weight	kg	5341	5718	6522	6830	7380	7708
WATER HEAT EXCHANGER							
Type *		S&T	S&T	S&T	S&T	S&T	S&T
Water Volume	l	255	255	307	307	485	485
Water flow rate	l/s	20.9	24.0	26.0	29.6	34.3	39.8
Water pressure drop***	kPa	26.5	33.3	19.8	25.0	24.2	31.7
AIR HEAT EXCHANGER							
Type *		MCH	MCH	MCH	MCH	MCH	MCH
FAN							
Type *		DPT	DPT	DPT	DPT	DPT	DPT
Drive *		BRS	BRS	VFD	VFD	BRS	BRS
Diameter	mm	800	800	800	800	800	800
Nominal air flow	l/s	51818	59220	66623	74025	74025	81428
Quantity	No.	14	16	18	20	20	22
Speed	rpm	700	700	700	700	700	700
Motor input	kW	9.8	11.2	12.6	14.0	14.0	15.4
COMPRESSOR							
Oil charge	l	20.0	20.0	26.0	26.0	36.0	36.0
Quantity	No.	2	2	2	2	2	2
SOUND LEVEL**							
Sound Power - Cooling	dB(A)	93	94	97	97	97	97
Sound Pressure level@1m distance - Cooling	dB(A)	72	73	75	75	75	75
REFRIGERANT CIRCUIT							
Refrigerant type		R134a	R134a	R134a	R134a	R134a	R134a
Refrigerant charge	kg	86	94	105	114	130	143
N. of circuits	No.	2	2	2	2	2	2
PIPING CONNECTIONS							
Evaporator water inlet/outlet	mm	168.3	168.3	168.3	168.3	219.1	219.1

All the performances (Cooling capacity, unit power input in cooling and EER) are based on the following conditions: evaporator 12.0/7.0°C; ambient 35.0°C, unit at full load operation; operating fluid: Water; fouling factor = 0.

(*)PHE: Plate Heat Exchanger; S&T: Single Pass Shell & Tube; MCH: Microchannel; DPT: Direct Propeller Type; DOL: Direct On Line - VFD: Inverter - BRS: Brushless

(**) Sound power level (referred to evaporator 12/7°C, ambient 35°C full load operation) are measured in accordance with ISO 9614 and Eurovent 8/1 for Eurovent certified units. The certification refers only to the overall sound power level, the sound pressure is calculated from the sound power level and are for information only and not considered binding. The minimum capacity indicated is referred to unit operating at standard Eurovent conditions. Dimensions and weights are for indication only and not considered binding. Before designing the installation, consult the official drawings available from the factory at request. All the data are referred to standard unit without options. All data are subject to change without notice.

(***) The value refers to the pressure drops in the evaporator only.

(****) In accordance with standard EN14825:2013, comfort low temperature, average climate. SEER and η_s values applicable Ecodesign regulation: (EU) No 2016/2281.

Eurovent certified values

EWAD~TZ-PL B

MODEL		EWAD950TZ -PL B2
COOLING PERFORMANCE		
Capacity - Cooling	kW	950
Capacity control - Type		Stepless
Capacity control - Minimum capacity	%	10
Unit power input - Cooling	kW	252
EER		3.76
ESEER		5.55
IPLV		6.64
SEASONAL ENERGY EFFICIENCY ****		
SEER (12/7°C)		6.31
$\eta_{s\ cool}(12/7°C)$	%	249
DIMENSIONS		
Height	mm	2540
Width	mm	2282
Length	mm	11387
WEIGHT		
Unit Weight	kg	7550
Operating Weight	kg	8000
WATER HEAT EXCHANGER		
Type *		S&T
Water Volume	l	453
Water flow rate	l/s	45.4
Water pressure drop***	kPa	29.0
AIR HEAT EXCHANGER		
Type *		MCH
FAN		
Type *		DPT
Drive *		BRS
Diameter	mm	800
Nominal air flow	l/s	88830
Quantity	No.	24
Speed	rpm	700
Motor input	kW	16.8
COMPRESSOR		
Oil charge	l	36.0
Quantity	No.	2
SOUND LEVEL**		
Sound Power - Cooling	dB(A)	97
Sound Pressure level@1m distance - Cooling	dB(A)	75
REFRIGERANT CIRCUIT		
Refrigerant type		R134a
Refrigerant charge	kg	156
N. of circuits	No.	2
PIPING CONNECTIONS		
Evaporator water inlet/outlet	mm	219.1

All the performances (Cooling capacity, unit power input in cooling and EER) are based on the following conditions: evaporator 12.0/7.0°C; ambient 35.0°C, unit at full load operation; operating fluid: Water; fouling factor = 0.

(*)PHE: Plate Heat Exchanger; S&T: Single Pass Shell & Tube; MCH: Microchannel; DPT: Direct Propeller Type; DOL: Direct On Line - VFD: Inverter - BRS: Brushless

(**) Sound power level (referred to evaporator 12/7°C, ambient 35°C full load operation) are measured in accordance with ISO 9614 and Eurovent 8/1 for Eurovent certified units. The certification refers only to the overall sound power level, the sound pressure is calculated from the sound power level and are for information only and not considered binding. The minimum capacity indicated is referred to unit operating at standard Eurovent conditions. Dimensions and weights are for indication only and not considered binding. Before designing the installation, consult the official drawings available from the factory at request. All the data are referred to standard unit without options. All data are subject to change without notice.

(***) The value refers to the pressure drops in the evaporator only.

(****) In accordance with standard EN14825:2013, comfort low temperature, average climate. SEER and η_s values applicable Ecodesign regulation: (EU) No 2016/2281.

Eurovent certified values

EWAD~TZ-PR B

MODEL		EWAD190TZ -PR B1	EWAD220TZ -PR B1	EWAD240TZ -PR B1	EWAD290TZ -PR B1	EWAD300TZ -PR B1	EWAD350TZ -PR B2
COOLING PERFORMANCE							
Capacity - Cooling	kW	187	218	247	279	317	382
Capacity control - Type		Stepless	Stepless	Stepless	Stepless	Stepless	Stepless
Capacity control - Minimum capacity	%	34	29	34	29	27	19
Unit power input - Cooling	kW	50.5	60.7	68.7	83.4	95.9	105
EER		3.71	3.59	3.59	3.35	3.31	3.64
ESEER		5.55	5.52	5.27	5.16	5.20	5.32
IPLV		6.49	6.35	6.23	6.07	6.04	6.30
SEASONAL ENERGY EFFICIENCY ****							
SEER (12/7°C)		5.29	5.38	5.34	5.25	5.38	5.28
$\eta_{s,cool}(12/7°C)$	%	209	212	211	207	212	208
DIMENSIONS							
Height	mm	2540	2540	2540	2540	2540	2540
Width	mm	2282	2282	2282	2282	2282	2282
Length	mm	4131	4131	4131	4131	5030	5887
WEIGHT							
Unit Weight	kg	2784	2784	2784	2784	3055	4907
Operating Weight	kg	2836	2836	2836	2836	3106	5169
WATER HEAT EXCHANGER							
Type *		PHE	PHE	PHE	PHE	PHE	S&T
Water Volume	l	50	50	50	50	50	255
Water flow rate	l/s	9.0	10.4	11.8	13.3	15.2	18.3
Water pressure drop***	kPa	10.6	11.0	13.4	17.1	21.5	20.4
AIR HEAT EXCHANGER							
Type *		MCH	MCH	MCH	MCH	MCH	MCH
FAN							
Type *		DPT	DPT	DPT	DPT	DPT	DPT
Drive *		BRS	BRS	BRS	BRS	BRS	BRS
Diameter	mm	800	800	800	800	800	800
Nominal air flow	l/s	29610	29610	29610	29610	37013	43369
Quantity	No.	8	8	8	8	10	12
Speed	rpm	700	700	700	700	700	700
Motor input	kW	5.6	5.6	5.6	5.6	7.0	8.4
COMPRESSOR							
Oil charge	l	10.0	10.0	10.0	10.0	10.0	20.0
Quantity	No.	1	1	1	1	1	2
SOUND LEVEL**							
Sound Power - Cooling	dB(A)	87	88	87	88	88	89
Sound Pressure level@1m distance - Cooling	dB(A)	67	68	67	68	68	68
REFRIGERANT CIRCUIT							
Refrigerant type		R134a	R134a	R134a	R134a	R134a	R134a
Refrigerant charge	kg	49	49	50	51	58	77
N. of circuits	No.	1	1	1	1	1	2
PIPING CONNECTIONS							
Evaporator water inlet/outlet	mm	88.9	88.9	114.3	114.3	114.3	168.3

All the performances (Cooling capacity, unit power input in cooling and EER) are based on the following conditions: evaporator 12.0/7.0°C; ambient 35.0°C, unit at full load operation; operating fluid: Water; fouling factor = 0.

(*PHE: Plate Heat Exchanger; S&T: Single Pass Shell & Tube; MCH: Microchannel; DPT: Direct Propeller Type; DOL: Direct On Line - VFD: Inverter - BRS: Brushless

(**) Sound power level (referred to evaporator 12/7°C, ambient 35°C full load operation) are measured in accordance with ISO 9614 and Eurovent 8/1 for Eurovent certified units. The certification refers only to the overall sound power level, the sound pressure is calculated from the sound power level and are for information only and not considered binding. The minimum capacity indicated is referred to unit operating at standard Eurovent conditions. Dimensions and weights are for indication only and not considered binding. Before designing the installation, consult the official drawings available from the factory at request. All the data are referred to standard unit without options. All data are subject to change without notice.

(***) The value refers to the pressure drops in the evaporator only.

(****) In accordance with standard EN14825:2013, comfort low temperature, average climate. SEER and η_s values applicable Ecodesign regulation: (EU) No 2016/2281.

Eurovent certified values

EWAD~TZ-PR B

MODEL		EWAD420TZ -PR B2	EWAD495TZ -PR B2	EWAD550TZ -PR B2	EWAD620TZ -PR B2	EWAD720TZ -PR B2	EWAD820TZ -PR B2
COOLING PERFORMANCE							
Capacity - Cooling	kW	437	505	543	620	717	833
Capacity control - Type		Stepless	Stepless	Stepless	Stepless	Stepless	Stepless
Capacity control - Minimum capacity	%	20	17	10	10	10	10
Unit power input - Cooling	kW	125	139	151	178	182	220
EER		3.49	3.62	3.59	3.47	3.94	3.78
ESEER		5.21	5.38	5.50	5.42	5.59	5.54
IPLV		6.27	6.47	6.53	6.47	6.73	6.60
SEASONAL ENERGY EFFICIENCY ****							
SEER (12/7°C)		5.33	5.6	5.53	5.57	6.29	6.31
$\eta_{s\ cool}(12/7°C)$	%	210	221	218	220	249	249
DIMENSIONS							
Height	mm	2540	2540	2540	2540	2540	2540
Width	mm	2282	2282	2282	2282	2282	2282
Length	mm	6786	7684	8579	9480	9587	10488
WEIGHT							
Unit Weight	kg	5078	5434	6212	6532	6930	7258
Operating Weight	kg	5341	5718	6522	6830	7380	7708
WATER HEAT EXCHANGER							
Type *		S&T	S&T	S&T	S&T	S&T	S&T
Water Volume	l	255	255	307	307	485	485
Water flow rate	l/s	20.9	24.2	26.0	29.6	34.3	39.8
Water pressure drop***	kPa	26.4	33.2	19.8	24.9	24.2	31.7
AIR HEAT EXCHANGER							
Type *		MCH	MCH	MCH	MCH	MCH	MCH
FAN							
Type *		DPT	DPT	DPT	DPT	DPT	DPT
Drive *		BRS	BRS	VFD	VFD	BRS	BRS
Diameter	mm	800	800	800	800	800	800
Nominal air flow	l/s	50423	57826	64879	72282	72282	79336
Quantity	No.	14	16	18	20	20	22
Speed	rpm	700	700	700	700	700	700
Motor input	kW	9.8	11.2	12.6	14.0	14.0	15.4
COMPRESSOR							
Oil charge	l	20.0	20.0	26.0	26.0	36.0	36.0
Quantity	No.	2	2	2	2	2	2
SOUND LEVEL **							
Sound Power - Cooling	dB(A)	90	90	94	95	95	95
Sound Pressure level@1m distance - Cooling	dB(A)	68	69	73	73	73	73
REFRIGERANT CIRCUIT							
Refrigerant type		R134a	R134a	R134a	R134a	R134a	R134a
Refrigerant charge	kg	86	94	105	114	130	143
N. of circuits	No.	2	2	2	2	2	2
PIPING CONNECTIONS							
Evaporator water inlet/outlet	mm	168.3	168.3	168.3	168.3	219.1	219.1

All the performances (Cooling capacity, unit power input in cooling and EER) are based on the following conditions: evaporator 12.0/7.0°C; ambient 35.0°C, unit at full load operation; operating fluid: Water; fouling factor = 0.

(*)PHE: Plate Heat Exchanger; S&T: Single Pass Shell & Tube; MCH: Microchannel; DPT: Direct Propeller Type; DOL: Direct On Line - VFD: Inverter - BRS: Brushless

(**) Sound power level (referred to evaporator 12/7°C, ambient 35°C full load operation) are measured in accordance with ISO 9614 and Eurovent 8/1 for Eurovent certified units. The certification refers only to the overall sound power level, the sound pressure is calculated from the sound power level and are for information only and not considered binding. The minimum capacity indicated is referred to unit operating at standard Eurovent conditions. Dimensions and weights are for indication only and not considered binding. Before designing the installation, consult the official drawings available from the factory at request. All the data are referred to standard unit without options. All data are subject to change without notice.

(***) The value refers to the pressure drops in the evaporator only.

(****) In accordance with standard EN14825:2013, comfort low temperature, average climate. SEER and η_s values applicable Ecodesign regulation: (EU) No 2016/2281.

Eurovent certified values

EWAD~TZ-PR B

MODEL		EWAD950TZ -PR B2
COOLING PERFORMANCE		
Capacity - Cooling	kW	950
Capacity control - Type		Stepless
Capacity control - Minimum capacity	%	10
Unit power input - Cooling	kW	252
EER		3.76
ESEER		5.55
IPLV		6.64
SEASONAL ENERGY EFFICIENCY ****		
SEER (12/7°C)		6.35
$\eta_{s\ cool}(12/7°C)$	%	251
DIMENSIONS		
Height	mm	2540
Width	mm	2282
Length	mm	11387
WEIGHT		
Unit Weight	kg	7550
Operating Weight	kg	8000
WATER HEAT EXCHANGER		
Type *		S&T
Water Volume	l	453
Water flow rate	l/s	45.4
Water pressure drop***	kPa	28.9
AIR HEAT EXCHANGER		
Type *		MCH
FAN		
Type *		DPT
Drive *		BRS
Diameter	mm	800
Nominal air flow	l/s	86738
Quantity	No.	24
Speed	rpm	700
Motor input	kW	16.8
COMPRESSOR		
Oil charge	l	36.0
Quantity	No.	2
SOUND LEVEL**		
Sound Power - Cooling	dB(A)	95
Sound Pressure level@1m distance - Cooling	dB(A)	73
REFRIGERANT CIRCUIT		
Refrigerant type		R134a
Refrigerant charge	kg	156
N. of circuits	No.	2
PIPING CONNECTIONS		
Evaporator water inlet/outlet	mm	219.1

All the performances (Cooling capacity, unit power input in cooling and EER) are based on the following conditions: evaporator 12.0/7.0°C; ambient 35.0°C, unit at full load operation; operating fluid: Water; fouling factor = 0.

(*)PHE: Plate Heat Exchanger; S&T: Single Pass Shell & Tube; MCH: Microchannel; DPT: Direct Propeller Type; DOL: Direct On Line - VFD: Inverter - BRS: Brushless

(**) Sound power level (referred to evaporator 12/7°C, ambient 35°C full load operation) are measured in accordance with ISO 9614 and Eurovent 8/1 for Eurovent certified units. The certification refers only to the overall sound power level, the sound pressure is calculated from the sound power level and are for information only and not considered binding. The minimum capacity indicated is referred to unit operating at standard Eurovent conditions. Dimensions and weights are for indication only and not considered binding. Before designing the installation, consult the official drawings available from the factory at request. All the data are referred to standard unit without options. All data are subject to change without notice.

(***) The value refers to the pressure drops in the evaporator only.

(****) In accordance with standard EN14825:2013, comfort low temperature, average climate. SEER and η_s values applicable Ecodesign regulation: (EU) No 2016/2281.

Eurovent certified values

EWAD~TZ-SS B

MODEL		EWAD160TZ -SS B1	EWAD190TZ -SS B1	EWAD240TZ -SS B1	EWAD270TZ -SS B1	EWAD300TZ -SS B1	EWAD360TZ -SS B1
POWER SUPPLY							
Phases	No.	3	3	3	3	3	3
Frequency	Hz	50	50	50	50	50	50
Voltage	V	400	400	400	400	400	400
Voltage tolerance Minimum	%	-10%	-10%	-10%	-10%	-10%	-10%
Voltage tolerance Maximum	%	10%	10%	10%	10%	10%	10%
UNIT							
Maximum inrush current	A	0	0	0	0	0	0
Nominal running current cooling	A	102	123	188	177	188	200
Maximum running current	A	130	149	160	187	220	246
Maximum current for wires sizing	A	141	156	174	187	239	247
FANS							
Nominal running current cooling	A	10.4	10.4	10.4	15.6	15.6	20.8
COMPRESSORS							
Phases	No.	3	3	3	3	3	3
Voltage	V	400	400	400	400	400	400
Voltage tolerance Minimum	%	-10%	-10%	-10%	-10%	-10%	-10%
Voltage tolerance Maximum	%	10%	10%	10%	10%	10%	10%
Maximum running current	A	119	139	150	171	204	225
Starting method		INV	INV	INV	INV	INV	INV

MODEL		EWAD380TZ -SS B2	EWAD450TZ -SS B2	EWAD495TZ -SS B2	EWAD570TZ -SS B2	EWAD610TZ -SS B2	EWAD660TZ -SS B2
POWER SUPPLY							
Phases	No.	3	3	3	3	3	3
Frequency	Hz	50	50	50	50	50	50
Voltage	V	400	400	400	400	400	400
Voltage tolerance Minimum	%	-10%	-10%	-10%	-10%	-10%	-10%
Voltage tolerance Maximum	%	10%	10%	10%	10%	10%	10%
UNIT							
Maximum inrush current	A	0	0	0	0	0	0
Nominal running current cooling	A	246	372	366	361	377	396
Maximum running current	A	298	320	350	374	439	466
Maximum current for wires sizing	A	313	349	368	374	479	483
FANS							
Nominal running current cooling	A	20.8	20.8	26	31.2	31.2	31.2
COMPRESSORS							
Phases	No.	3	3	3	3	3	3
Voltage	V	400	400	400	400	400	400
Voltage tolerance Minimum	%	-10%	-10%	-10%	-10%	-10%	-10%
Voltage tolerance Maximum	%	10%	10%	10%	10%	10%	10%
Maximum running current	A	139	150	162	171	204	218
Starting method		INV	INV	INV	INV	INV	INV

Fluid: Water

Allowed voltage tolerance $\pm 10\%$. Voltage unbalance between phases must be within $\pm 3\%$.

Maximum starting current: In case of inverter driven units, no inrush current at start up is experienced.

Nominal current in cooling mode is referred to the following conditions: evaporator 12/7°C; ambient 35°C; compressors + fans current.

Maximum running current is based on max compressor absorbed current in its envelope and max fans absorbed current

Maximum unit current for wires sizing is based on minimum allowed voltage

Maximum current for wires sizing: (compressors full load ampere + fans current) x 1,1.

The data are referred to the standard unit without options.

For the electrical data of the hydronic kit refer to "Options technical data"

All data are subject to change without notice. Please refer to unit nameplate data.

EWAD~TZ-SS B

MODEL		EWAD700TZ -SS B2	EWAD820TZ -SS B2	EWAD900TZ -SS B2	EWAD990TZ -SS B2	EWADC10TZ -SS B2	EWADC11TZ -SS B2
POWER SUPPLY							
Phases	No.	3	3	3	3	3	3
Frequency	Hz	50	50	50	50	50	50
Voltage	V	400	400	400	400	400	400
Voltage tolerance Minimum	%	-10%	-10%	-10%	-10%	-10%	-10%
Voltage tolerance Maximum	%	10%	10%	10%	10%	10%	10%
UNIT							
Maximum inrush current	A	0	0	0	0	0	0
Nominal running current cooling	A	414	429	501	528	563	597
Maximum running current	A	486	537	599	652	708	768
Maximum current for wires sizing	A	488	582	651	709	770	836
FANS							
Nominal running current cooling	A	36.4	56	56	64	72	80
COMPRESSORS							
Phases	No.	3	3	3	3	3	3
Voltage	V	400	400	400	400	400	400
Voltage tolerance Minimum	%	-10%	-10%	-10%	-10%	-10%	-10%
Voltage tolerance Maximum	%	10%	10%	10%	10%	10%	10%
Maximum running current	A	225	241	272	294	318	344
Starting method		INV	INV	INV	INV	INV	INV

Fluid: Water

Allowed voltage tolerance $\pm 10\%$. Voltage unbalance between phases must be within $\pm 3\%$.

Maximum starting current: In case of inverter driven units, no inrush current at start up is experienced.

Nominal current in cooling mode is referred to the following conditions: evaporator 12/7°C; ambient 35°C; compressors + fans current.

Maximum running current is based on max compressor absorbed current in its envelope and max fans absorbed current

Maximum unit current for wires sizing is based on minimum allowed voltage

Maximum current for wires sizing: (compressors full load ampere + fans current) $\times 1,1$.

The data are referred to the standard unit without options.

For the electrical data of the hydronic kit refer to "Options technical data"

All data are subject to change without notice. Please refer to unit nameplate data.

EWAD~TZ-SL B

MODEL		EWAD160TZ -SL B1	EWAD190TZ -SL B1	EWAD240TZ -SL B1	EWAD270TZ -SL B1	EWAD300TZ -SL B1	EWAD360TZ -SL B1
POWER SUPPLY							
Phases	No.	3	3	3	3	3	3
Frequency	Hz	50	50	50	50	50	50
Voltage	V	400	400	400	400	400	400
Voltage tolerance Minimum	%	-10%	-10%	-10%	-10%	-10%	-10%
Voltage tolerance Maximum	%	10%	10%	10%	10%	10%	10%
UNIT							
Maximum inrush current	A	0	0	0	0	0	0
Nominal running current cooling	A	102	123	188	177	188	200
Maximum running current	A	130	149	160	187	220	246
Maximum current for wires sizing	A	141	156	174	187	239	247
FANS							
Nominal running current cooling	A	10.4	10.4	10.4	15.6	15.6	20.8
COMPRESSORS							
Phases	No.	3	3	3	3	3	3
Voltage	V	400	400	400	400	400	400
Voltage tolerance Minimum	%	-10%	-10%	-10%	-10%	-10%	-10%
Voltage tolerance Maximum	%	10%	10%	10%	10%	10%	10%
Maximum running current	A	119	139	150	171	204	225
Starting method		INV	INV	INV	INV	INV	INV

MODEL		EWAD380TZ -SL B2	EWAD450TZ -SL B2	EWAD495TZ -SL B2	EWAD570TZ -SL B2	EWAD610TZ -SL B2	EWAD660TZ -SL B2
POWER SUPPLY							
Phases	No.	3	3	3	3	3	3
Frequency	Hz	50	50	50	50	50	50
Voltage	V	400	400	400	400	400	400
Voltage tolerance Minimum	%	-10%	-10%	-10%	-10%	-10%	-10%
Voltage tolerance Maximum	%	10%	10%	10%	10%	10%	10%
UNIT							
Maximum inrush current	A	0	0	0	0	0	0
Nominal running current cooling	A	246	372	366	361	377	396
Maximum running current	A	298	320	350	374	439	466
Maximum current for wires sizing	A	313	349	368	374	479	483
FANS							
Nominal running current cooling	A	20.8	20.8	26	31.2	31.2	31.2
COMPRESSORS							
Phases	No.	3	3	3	3	3	3
Voltage	V	400	400	400	400	400	400
Voltage tolerance Minimum	%	-10%	-10%	-10%	-10%	-10%	-10%
Voltage tolerance Maximum	%	10%	10%	10%	10%	10%	10%
Maximum running current	A	139	150	162	171	204	218
Starting method		INV	INV	INV	INV	INV	INV

Fluid: Water

Allowed voltage tolerance $\pm 10\%$. Voltage unbalance between phases must be within $\pm 3\%$.

Maximum starting current: In case of inverter driven units, no inrush current at start up is experienced.

Nominal current in cooling mode is referred to the following conditions: evaporator 12/7°C; ambient 35°C; compressors + fans current.

Maximum running current is based on max compressor absorbed current in its envelope and max fans absorbed current

Maximum unit current for wires sizing is based on minimum allowed voltage

Maximum current for wires sizing: (compressors full load ampere + fans current) x 1,1.

The data are referred to the standard unit without options.

For the electrical data of the hydronic kit refer to "Options technical data"

All data are subject to change without notice. Please refer to unit nameplate data.

EWAD~TZ-SL B

MODEL		EWAD700TZ -SL B2	EWAD820TZ -SL B2	EWAD900TZ -SL B2	EWAD990TZ -SL B2	EWADC10TZ -SL B2	EWADC11TZ -SL B2
POWER SUPPLY							
Phases	No.	3	3	3	3	3	3
Frequency	Hz	50	50	50	50	50	50
Voltage	V	400	400	400	400	400	400
Voltage tolerance Minimum	%	-10%	-10%	-10%	-10%	-10%	-10%
Voltage tolerance Maximum	%	10%	10%	10%	10%	10%	10%
UNIT							
Maximum inrush current	A	0	0	0	0	0	0
Nominal running current cooling	A	414	429	501	528	563	597
Maximum running current	A	486	537	599	652	708	768
Maximum current for wires sizing	A	488	582	651	709	770	836
FANS							
Nominal running current cooling	A	36.4	56	56	64	72	80
COMPRESSORS							
Phases	No.	3	3	3	3	3	3
Voltage	V	400	400	400	400	400	400
Voltage tolerance Minimum	%	-10%	-10%	-10%	-10%	-10%	-10%
Voltage tolerance Maximum	%	10%	10%	10%	10%	10%	10%
Maximum running current	A	225	241	272	294	318	344
Starting method		INV	INV	INV	INV	INV	INV

Fluid: Water

Allowed voltage tolerance $\pm 10\%$. Voltage unbalance between phases must be within $\pm 3\%$.

Maximum starting current: In case of inverter driven units, no inrush current at start up is experienced.

Nominal current in cooling mode is referred to the following conditions: evaporator 12/7°C; ambient 35°C; compressors + fans current.

Maximum running current is based on max compressor absorbed current in its envelope and max fans absorbed current

Maximum unit current for wires sizing is based on minimum allowed voltage

Maximum current for wires sizing: (compressors full load ampere + fans current) x 1,1.

The data are referred to the standard unit without options.

For the electrical data of the hydronic kit refer to "Options technical data"

All data are subject to change without notice. Please refer to unit nameplate data.

EWAD~TZ-SR B

MODEL		EWAD160TZ -SR B1	EWAD190TZ -SR B1	EWAD240TZ -SR B1	EWAD270TZ -SR B1	EWAD300TZ -SR B1	EWAD360TZ -SR B1
POWER SUPPLY							
Phases	No.	3	3	3	3	3	3
Frequency	Hz	50	50	50	50	50	50
Voltage	V	400	400	400	400	400	400
Voltage tolerance Minimum	%	-10%	-10%	-10%	-10%	-10%	-10%
Voltage tolerance Maximum	%	10%	10%	10%	10%	10%	10%
UNIT							
Maximum inrush current	A	0	0	0	0	0	0
Nominal running current cooling	A	102	123	188	177	188	200
Maximum running current	A	130	149	160	187	220	246
Maximum current for wires sizing	A	141	156	174	187	239	247
FANS							
Nominal running current cooling	A	10.4	10.4	10.4	15.6	15.6	20.8
COMPRESSORS							
Phases	No.	3	3	3	3	3	3
Voltage	V	400	400	400	400	400	400
Voltage tolerance Minimum	%	-10%	-10%	-10%	-10%	-10%	-10%
Voltage tolerance Maximum	%	10%	10%	10%	10%	10%	10%
Maximum running current	A	119	139	150	171	204	225
Starting method		INV	INV	INV	INV	INV	INV

MODEL		EWAD380TZ -SR B2	EWAD450TZ -SR B2	EWAD495TZ -SR B2	EWAD570TZ -SR B2	EWAD610TZ -SR B2	EWAD660TZ -SR B2
POWER SUPPLY							
Phases	No.	3	3	3	3	3	3
Frequency	Hz	50	50	50	50	50	50
Voltage	V	400	400	400	400	400	400
Voltage tolerance Minimum	%	-10%	-10%	-10%	-10%	-10%	-10%
Voltage tolerance Maximum	%	10%	10%	10%	10%	10%	10%
UNIT							
Maximum inrush current	A	0	0	0	0	0	0
Nominal running current cooling	A	247	374	368	363	378	398
Maximum running current	A	298	320	350	374	439	466
Maximum current for wires sizing	A	313	349	368	374	479	483
FANS							
Nominal running current cooling	A	20.8	20.8	26	31.2	31.2	31.2
COMPRESSORS							
Phases	No.	3	3	3	3	3	3
Voltage	V	400	400	400	400	400	400
Voltage tolerance Minimum	%	-10%	-10%	-10%	-10%	-10%	-10%
Voltage tolerance Maximum	%	10%	10%	10%	10%	10%	10%
Maximum running current	A	139	150	162	171	204	218
Starting method		INV	INV	INV	INV	INV	INV

Fluid: Water

Allowed voltage tolerance $\pm 10\%$. Voltage unbalance between phases must be within $\pm 3\%$.

Maximum starting current: In case of inverter driven units, no inrush current at start up is experienced.

Nominal current in cooling mode is referred to the following conditions: evaporator 12/7°C; ambient 35°C; compressors + fans current.

Maximum running current is based on max compressor absorbed current in its envelope and max fans absorbed current

Maximum unit current for wires sizing is based on minimum allowed voltage

Maximum current for wires sizing: (compressors full load ampere + fans current) x 1,1.

The data are referred to the standard unit without options.

For the electrical data of the hydronic kit refer to "Options technical data"

All data are subject to change without notice. Please refer to unit nameplate data.

EWAD~TZ-SR B

MODEL		EWAD700TZ -SR B2	EWAD820TZ -SR B2	EWAD900TZ -SR B2	EWAD990TZ -SR B2	EWADC10TZ -SR B2	EWADC11TZ -SR B2
POWER SUPPLY							
Phases	No.	3	3	3	3	3	3
Frequency	Hz	50	50	50	50	50	50
Voltage	V	400	400	400	400	400	400
Voltage tolerance Minimum	%	-10%	-10%	-10%	-10%	-10%	-10%
Voltage tolerance Maximum	%	10%	10%	10%	10%	10%	10%
UNIT							
Maximum inrush current	A	0	0	0	0	0	0
Nominal running current cooling	A	416	422	496	530	561	599
Maximum running current	A	486	523	585	635	688	745
Maximum current for wires sizing	A	488	568	637	692	750	813
FANS							
Nominal running current cooling	A	36.4	41.6	41.6	46.8	52	57.2
COMPRESSORS							
Phases	No.	3	3	3	3	3	3
Voltage	V	400	400	400	400	400	400
Voltage tolerance Minimum	%	-10%	-10%	-10%	-10%	-10%	-10%
Voltage tolerance Maximum	%	10%	10%	10%	10%	10%	10%
Maximum running current	A	225	241	272	294	318	344
Starting method		INV	INV	INV	INV	INV	INV

Fluid: Water

Allowed voltage tolerance $\pm 10\%$. Voltage unbalance between phases must be within $\pm 3\%$.

Maximum starting current: In case of inverter driven units, no inrush current at start up is experienced.

Nominal current in cooling mode is referred to the following conditions: evaporator 12/7°C; ambient 35°C; compressors + fans current.

Maximum running current is based on max compressor absorbed current in its envelope and max fans absorbed current

Maximum unit current for wires sizing is based on minimum allowed voltage

Maximum current for wires sizing: (compressors full load ampere + fans current) $\times 1,1$.

The data are referred to the standard unit without options.

For the electrical data of the hydronic kit refer to "Options technical data"

All data are subject to change without notice. Please refer to unit nameplate data.

EWAD~TZ-XS B

MODEL		EWAD190TZ -XS B1	EWAD220TZ -XS B1	EWAD240TZ -XS B1	EWAD290TZ -XS B1	EWAD320TZ -XS B1	EWAD360TZ -XS B2
POWER SUPPLY							
Phases	No.	3	3	3	3	3	3
Frequency	Hz	50	50	50	50	50	50
Voltage	V	400	400	400	400	400	400
Voltage tolerance Minimum	%	-10%	-10%	-10%	-10%	-10%	-10%
Voltage tolerance Maximum	%	10%	10%	10%	10%	10%	10%
UNIT							
Maximum inrush current	A	0	0	0	0	0	0
Nominal running current cooling	A	110	113	186	186	192	225
Maximum running current	A	130	149	166	198	225	256
Maximum current for wires sizing	A	141	155	180	214	245	276
FANS							
Nominal running current cooling	A	15.6	15.6	15.6	20.8	20.8	26
COMPRESSORS							
Phases	No.	3	3	3	3	3	3
Voltage	V	400	400	400	400	400	400
Voltage tolerance Minimum	%	-10%	-10%	-10%	-10%	-10%	-10%
Voltage tolerance Maximum	%	10%	10%	10%	10%	10%	10%
Maximum running current	A	115	133	151	177	204	115
Starting method		INV	INV	INV	INV	INV	INV

MODEL		EWAD420TZ -XS B2	EWAD450TZ -XS B2	EWAD540TZ -XS B2	EWAD570TZ -XS B2	EWAD610TZ -XS B2	EWAD660TZ -XS B2
POWER SUPPLY							
Phases	No.	3	3	3	3	3	3
Frequency	Hz	50	50	50	50	50	50
Voltage	V	400	400	400	400	400	400
Voltage tolerance Minimum	%	-10%	-10%	-10%	-10%	-10%	-10%
Voltage tolerance Maximum	%	10%	10%	10%	10%	10%	10%
UNIT							
Maximum inrush current	A	0	0	0	0	0	0
Nominal running current cooling	A	231	371	383	392	390	387
Maximum running current	A	292	333	358	385	417	450
Maximum current for wires sizing	A	305	361	389	418	453	489
FANS							
Nominal running current cooling	A	26	31.2	31.2	31.2	36.4	41.6
COMPRESSORS							
Phases	No.	3	3	3	3	3	3
Voltage	V	400	400	400	400	400	400
Voltage tolerance Minimum	%	-10%	-10%	-10%	-10%	-10%	-10%
Voltage tolerance Maximum	%	10%	10%	10%	10%	10%	10%
Maximum running current	A	133	151	164	177	190	204
Starting method		INV	INV	INV	INV	INV	INV

Fluid: Water

Allowed voltage tolerance $\pm 10\%$. Voltage unbalance between phases must be within $\pm 3\%$.

Maximum starting current: In case of inverter driven units, no inrush current at start up is experienced.

Nominal current in cooling mode is referred to the following conditions: evaporator 12/7°C; ambient 35°C; compressors + fans current.

Maximum running current is based on max compressor absorbed current in its envelope and max fans absorbed current

Maximum unit current for wires sizing is based on minimum allowed voltage

Maximum current for wires sizing: (compressors full load ampere + fans current) x 1,1.

The data are referred to the standard unit without options.

For the electrical data of the hydronic kit refer to "Options technical data"

All data are subject to change without notice. Please refer to unit nameplate data.

EWAD~TZ-XS B

MODEL		EWAD680TZ -XS B2	EWAD770TZ -XS B2	EWAD850TZ -XS B2	EWAD910TZ -XS B2	EWADC10TZ -XS B2	EWADC11TZ -XS B2
POWER SUPPLY							
Phases	No.	3	3	3	3	3	3
Frequency	Hz	50	50	50	50	50	50
Voltage	V	400	400	400	400	400	400
Voltage tolerance Minimum	%	-10%	-10%	-10%	-10%	-10%	-10%
Voltage tolerance Maximum	%	10%	10%	10%	10%	10%	10%
UNIT							
Maximum inrush current	A	0	0	0	0	0	0
Nominal running current cooling	A	395	394	451	469	500	537
Maximum running current	A	478	508	562	590	640	694
Maximum current for wires sizing	A	489	551	612	642	697	756
FANS							
Nominal running current cooling	A	41.6	41.6	41.6	46.8	52	57.2
COMPRESSORS							
Phases	No.	3	3	3	3	3	3
Voltage	V	400	400	400	400	400	400
Voltage tolerance Minimum	%	-10%	-10%	-10%	-10%	-10%	-10%
Voltage tolerance Maximum	%	10%	10%	10%	10%	10%	10%
Maximum running current	A	218	233	260	272	294	318
Starting method		INV	INV	INV	INV	INV	INV

Fluid: Water

Allowed voltage tolerance $\pm 10\%$. Voltage unbalance between phases must be within $\pm 3\%$.

Maximum starting current: In case of inverter driven units, no inrush current at start up is experienced.

Nominal current in cooling mode is referred to the following conditions: evaporator 12/7°C; ambient 35°C; compressors + fans current.

Maximum running current is based on max compressor absorbed current in its envelope and max fans absorbed current

Maximum unit current for wires sizing is based on minimum allowed voltage

Maximum current for wires sizing: (compressors full load ampere + fans current) $\times 1,1$.

The data are referred to the standard unit without options.

For the electrical data of the hydronic kit refer to "Options technical data"

All data are subject to change without notice. Please refer to unit nameplate data.

EWAD~TZ-XL B

MODEL		EWAD190TZ -XL B1	EWAD220TZ -XL B1	EWAD240TZ -XL B1	EWAD290TZ -XL B1	EWAD320TZ -XL B1	EWAD360TZ -XL B2
POWER SUPPLY							
Phases	No.	3	3	3	3	3	3
Frequency	Hz	50	50	50	50	50	50
Voltage	V	400	400	400	400	400	400
Voltage tolerance Minimum	%	-10%	-10%	-10%	-10%	-10%	-10%
Voltage tolerance Maximum	%	10%	10%	10%	10%	10%	10%
UNIT							
Maximum inrush current	A	0	0	0	0	0	0
Nominal running current cooling	A	110	113	186	186	192	225
Maximum running current	A	130	149	166	198	225	256
Maximum current for wires sizing	A	141	155	180	214	245	276
FANS							
Nominal running current cooling	A	15.6	15.6	15.6	20.8	20.8	26
COMPRESSORS							
Phases	No.	3	3	3	3	3	3
Voltage	V	400	400	400	400	400	400
Voltage tolerance Minimum	%	-10%	-10%	-10%	-10%	-10%	-10%
Voltage tolerance Maximum	%	10%	10%	10%	10%	10%	10%
Maximum running current	A	115	133	151	177	204	115
Starting method		INV	INV	INV	INV	INV	INV

MODEL		EWAD420TZ -XL B2	EWAD450TZ -XL B2	EWAD540TZ -XL B2	EWAD570TZ -XL B2	EWAD610TZ -XL B2	EWAD660TZ -XL B2
POWER SUPPLY							
Phases	No.	3	3	3	3	3	3
Frequency	Hz	50	50	50	50	50	50
Voltage	V	400	400	400	400	400	400
Voltage tolerance Minimum	%	-10%	-10%	-10%	-10%	-10%	-10%
Voltage tolerance Maximum	%	10%	10%	10%	10%	10%	10%
UNIT							
Maximum inrush current	A	0	0	0	0	0	0
Nominal running current cooling	A	231	371	383	392	390	387
Maximum running current	A	292	333	358	385	417	450
Maximum current for wires sizing	A	305	361	389	418	453	489
FANS							
Nominal running current cooling	A	26	31.2	31.2	31.2	36.4	41.6
COMPRESSORS							
Phases	No.	3	3	3	3	3	3
Voltage	V	400	400	400	400	400	400
Voltage tolerance Minimum	%	-10%	-10%	-10%	-10%	-10%	-10%
Voltage tolerance Maximum	%	10%	10%	10%	10%	10%	10%
Maximum running current	A	133	151	164	177	190	204
Starting method		INV	INV	INV	INV	INV	INV

Fluid: Water

Allowed voltage tolerance $\pm 10\%$. Voltage unbalance between phases must be within $\pm 3\%$.

Maximum starting current: In case of inverter driven units, no inrush current at start up is experienced.

Nominal current in cooling mode is referred to the following conditions: evaporator 12/7°C; ambient 35°C; compressors + fans current.

Maximum running current is based on max compressor absorbed current in its envelope and max fans absorbed current

Maximum unit current for wires sizing is based on minimum allowed voltage

Maximum current for wires sizing: (compressors full load ampere + fans current) x 1,1.

The data are referred to the standard unit without options.

For the electrical data of the hydronic kit refer to "Options technical data"

All data are subject to change without notice. Please refer to unit nameplate data.

EWAD~TZ-XL B

MODEL		EWAD680TZ -XL B2	EWAD770TZ -XL B2	EWAD850TZ -XL B2	EWAD910TZ -XL B2	EWADC10TZ -XL B2	EWADC11TZ -XL B2
POWER SUPPLY							
Phases	No.	3	3	3	3	3	3
Frequency	Hz	50	50	50	50	50	50
Voltage	V	400	400	400	400	400	400
Voltage tolerance Minimum	%	-10%	-10%	-10%	-10%	-10%	-10%
Voltage tolerance Maximum	%	10%	10%	10%	10%	10%	10%
UNIT							
Maximum inrush current	A	0	0	0	0	0	0
Nominal running current cooling	A	395	394	451	469	500	537
Maximum running current	A	478	508	562	590	640	694
Maximum current for wires sizing	A	489	551	612	642	697	756
FANS							
Nominal running current cooling	A	41.6	41.6	41.6	46.8	52	57.2
COMPRESSORS							
Phases	No.	3	3	3	3	3	3
Voltage	V	400	400	400	400	400	400
Voltage tolerance Minimum	%	-10%	-10%	-10%	-10%	-10%	-10%
Voltage tolerance Maximum	%	10%	10%	10%	10%	10%	10%
Maximum running current	A	218	233	260	272	294	318
Starting method		INV	INV	INV	INV	INV	INV

Fluid: Water

Allowed voltage tolerance $\pm 10\%$. Voltage unbalance between phases must be within $\pm 3\%$.

Maximum starting current: In case of inverter driven units, no inrush current at start up is experienced.

Nominal current in cooling mode is referred to the following conditions: evaporator 12/7°C; ambient 35°C; compressors + fans current.

Maximum running current is based on max compressor absorbed current in its envelope and max fans absorbed current

Maximum unit current for wires sizing is based on minimum allowed voltage

Maximum current for wires sizing: (compressors full load ampere + fans current) x 1,1.

The data are referred to the standard unit without options.

For the electrical data of the hydronic kit refer to "Options technical data"

All data are subject to change without notice. Please refer to unit nameplate data.

EWAD~TZ-XR B

MODEL		EWAD190TZ -XR B1	EWAD220TZ -XR B1	EWAD240TZ -XR B1	EWAD290TZ -XR B1	EWAD320TZ -XR B1	EWAD360TZ -XR B2
POWER SUPPLY							
Phases	No.	3	3	3	3	3	3
Frequency	Hz	50	50	50	50	50	50
Voltage	V	400	400	400	400	400	400
Voltage tolerance Minimum	%	-10%	-10%	-10%	-10%	-10%	-10%
Voltage tolerance Maximum	%	10%	10%	10%	10%	10%	10%
UNIT							
Maximum inrush current	A	0	0	0	0	0	0
Nominal running current cooling	A	110	113	186	186	192	226
Maximum running current	A	130	149	166	198	225	256
Maximum current for wires sizing	A	141	155	180	214	245	276
FANS							
Nominal running current cooling	A	15.6	15.6	15.6	20.8	20.8	26
COMPRESSORS							
Phases	No.	3	3	3	3	3	3
Voltage	V	400	400	400	400	400	400
Voltage tolerance Minimum	%	-10%	-10%	-10%	-10%	-10%	-10%
Voltage tolerance Maximum	%	10%	10%	10%	10%	10%	10%
Maximum running current	A	115	133	151	177	204	115
Starting method		INV	INV	INV	INV	INV	INV

MODEL		EWAD420TZ -XR B2	EWAD450TZ -XR B2	EWAD540TZ -XR B2	EWAD570TZ -XR B2	EWAD610TZ -XR B2	EWAD660TZ -XR B2
POWER SUPPLY							
Phases	No.	3	3	3	3	3	3
Frequency	Hz	50	50	50	50	50	50
Voltage	V	400	400	400	400	400	400
Voltage tolerance Minimum	%	-10%	-10%	-10%	-10%	-10%	-10%
Voltage tolerance Maximum	%	10%	10%	10%	10%	10%	10%
UNIT							
Maximum inrush current	A	0	0	0	0	0	0
Nominal running current cooling	A	231	373	385	393	391	389
Maximum running current	A	292	333	358	385	417	450
Maximum current for wires sizing	A	305	361	389	418	453	489
FANS							
Nominal running current cooling	A	26	31.2	31.2	31.2	36.4	41.6
COMPRESSORS							
Phases	No.	3	3	3	3	3	3
Voltage	V	400	400	400	400	400	400
Voltage tolerance Minimum	%	-10%	-10%	-10%	-10%	-10%	-10%
Voltage tolerance Maximum	%	10%	10%	10%	10%	10%	10%
Maximum running current	A	133	151	164	177	190	204
Starting method		INV	INV	INV	INV	INV	INV

Fluid: Water

Allowed voltage tolerance ± 10%. Voltage unbalance between phases must be within ± 3%.

Maximum starting current: In case of inverter driven units, no inrush current at start up is experienced.

Nominal current in cooling mode is referred to the following conditions: evaporator 12/7°C; ambient 35°C; compressors + fans current.

Maximum running current is based on max compressor absorbed current in its envelope and max fans absorbed current

Maximum unit current for wires sizing is based on minimum allowed voltage

Maximum current for wires sizing: (compressors full load ampere + fans current) x 1,1.

The data are referred to the standard unit without options.

For the electrical data of the hydronic kit refer to "Options technical data"

All data are subject to change without notice. Please refer to unit nameplate data.

EWAD~TZ-XR B

MODEL		EWAD680TZ -XR B2	EWAD770TZ -XR B2	EWAD850TZ -XR B2	EWAD910TZ -XR B2	EWADC10TZ -XR B2	EWADC11TZ -XR B2
POWER SUPPLY							
Phases	No.	3	3	3	3	3	3
Frequency	Hz	50	50	50	50	50	50
Voltage	V	400	400	400	400	400	400
Voltage tolerance Minimum	%	-10%	-10%	-10%	-10%	-10%	-10%
Voltage tolerance Maximum	%	10%	10%	10%	10%	10%	10%
UNIT							
Maximum inrush current	A	0	0	0	0	0	0
Nominal running current cooling	A	396	395	453	471	502	539
Maximum running current	A	478	508	562	590	640	694
Maximum current for wires sizing	A	489	551	612	642	697	756
FANS							
Nominal running current cooling	A	41.6	41.6	41.6	46.8	52	57.2
COMPRESSORS							
Phases	No.	3	3	3	3	3	3
Voltage	V	400	400	400	400	400	400
Voltage tolerance Minimum	%	-10%	-10%	-10%	-10%	-10%	-10%
Voltage tolerance Maximum	%	10%	10%	10%	10%	10%	10%
Maximum running current	A	218	233	260	272	294	318
Starting method		INV	INV	INV	INV	INV	INV

Fluid: Water

Allowed voltage tolerance $\pm 10\%$. Voltage unbalance between phases must be within $\pm 3\%$.

Maximum starting current: In case of inverter driven units, no inrush current at start up is experienced.

Nominal current in cooling mode is referred to the following conditions: evaporator 12/7°C; ambient 35°C; compressors + fans current.

Maximum running current is based on max compressor absorbed current in its envelope and max fans absorbed current

Maximum unit current for wires sizing is based on minimum allowed voltage

Maximum current for wires sizing: (compressors full load ampere + fans current) x 1,1.

The data are referred to the standard unit without options.

For the electrical data of the hydronic kit refer to "Options technical data"

All data are subject to change without notice. Please refer to unit nameplate data.

EWAD~TZ-PS B

MODEL		EWAD190TZ -PS B1	EWAD220TZ -PS B1	EWAD240TZ -PS B1	EWAD290TZ -PS B1	EWAD300TZ -PS B1	EWAD350TZ -PS B2
POWER SUPPLY							
Phases	No.	3	3	3	3	3	3
Frequency	Hz	50	50	50	50	50	50
Voltage	V	400	400	400	400	400	400
Voltage tolerance Minimum	%	-10%	-10%	-10%	-10%	-10%	-10%
Voltage tolerance Maximum	%	10%	10%	10%	10%	10%	10%
UNIT							
Maximum inrush current	A	0	0	0	0	0	0
Nominal running current cooling	A	101	104	172	177	177	208
Maximum running current	A	126	144	162	188	218	246
Maximum current for wires sizing	A	136	150	176	205	238	267
FANS							
Nominal running current cooling	A	11.2	11.2	11.2	11.2	14	16.8
COMPRESSORS							
Phases	No.	3	3	3	3	3	3
Voltage	V	400	400	400	400	400	400
Voltage tolerance Minimum	%	-10%	-10%	-10%	-10%	-10%	-10%
Voltage tolerance Maximum	%	10%	10%	10%	10%	10%	10%
Maximum running current	A	115	133	151	177	204	115
Starting method		INV	INV	INV	INV	INV	INV

MODEL		EWAD420TZ -PS B2	EWAD495TZ -PS B2	EWAD550TZ -PS B2	EWAD620TZ -PS B2	EWAD720TZ -PS B2	EWAD820TZ -PS B2
POWER SUPPLY							
Phases	No.	3	3	3	3	3	3
Frequency	Hz	50	50	50	50	50	50
Voltage	V	400	400	400	400	400	400
Voltage tolerance Minimum	%	-10%	-10%	-10%	-10%	-10%	-10%
Voltage tolerance Maximum	%	10%	10%	10%	10%	10%	10%
UNIT							
Maximum inrush current	A	0	0	0	0	0	0
Nominal running current cooling	A	211	346	258	298	316	375
Maximum running current	A	285	324	352	436	437	512
Maximum current for wires sizing	A	298	352	383	476	475	557
FANS							
Nominal running current cooling	A	19.6	22.4	25.2	28	28	30.8
COMPRESSORS							
Phases	No.	3	3	3	3	3	3
Voltage	V	400	400	400	400	400	400
Voltage tolerance Minimum	%	-10%	-10%	-10%	-10%	-10%	-10%
Voltage tolerance Maximum	%	10%	10%	10%	10%	10%	10%
Maximum running current	A	133	151	164	204	205	241
Starting method		INV	INV	INV	INV	INV	INV

Fluid: Water

Allowed voltage tolerance $\pm 10\%$. Voltage unbalance between phases must be within $\pm 3\%$.

Maximum starting current: In case of inverter driven units, no inrush current at start up is experienced.

Nominal current in cooling mode is referred to the following conditions: evaporator 12/7°C; ambient 35°C; compressors + fans current.

Maximum running current is based on max compressor absorbed current in its envelope and max fans absorbed current

Maximum unit current for wires sizing is based on minimum allowed voltage

Maximum current for wires sizing: (compressors full load ampere + fans current) x 1,1.

The data are referred to the standard unit without options.

For the electrical data of the hydronic kit refer to "Options technical data"

All data are subject to change without notice. Please refer to unit nameplate data.

EWAD~TZ-PS B

MODEL		EWAD950TZ -PS B2
POWER SUPPLY		
Phases	No.	3
Frequency	Hz	50
Voltage	V	400
Voltage tolerance Minimum	%	-10%
Voltage tolerance Maximum	%	10%
UNIT		
Maximum inrush current	A	0
Nominal running current cooling	A	424
Maximum running current	A	577
Maximum current for wires sizing	A	629
FANS		
Nominal running current cooling	A	33.6
COMPRESSORS		
Phases	No.	3
Voltage	V	400
Voltage tolerance Minimum	%	-10%
Voltage tolerance Maximum	%	10%
Maximum running current	A	272
Starting method		INV

Fluid: Water

Allowed voltage tolerance $\pm 10\%$. Voltage unbalance between phases must be within $\pm 3\%$.

Maximum starting current: In case of inverter driven units, no inrush current at start up is experienced.

Nominal current in cooling mode is referred to the following conditions: evaporator 12/7°C; ambient 35°C; compressors + fans current.

Maximum running current is based on max compressor absorbed current in its envelope and max fans absorbed current

Maximum unit current for wires sizing is based on minimum allowed voltage

Maximum current for wires sizing: (compressors full load ampere + fans current) x 1,1.

The data are referred to the standard unit without options.

For the electrical data of the hydronic kit refer to "Options technical data"

All data are subject to change without notice. Please refer to unit nameplate data.

EWAD~TZ-PL B

MODEL		EWAD190TZ -PL B1	EWAD220TZ -PL B1	EWAD240TZ -PL B1	EWAD290TZ -PL B1	EWAD300TZ -PL B1	EWAD350TZ -PL B2
POWER SUPPLY							
Phases	No.	3	3	3	3	3	3
Frequency	Hz	50	50	50	50	50	50
Voltage	V	400	400	400	400	400	400
Voltage tolerance Minimum	%	-10%	-10%	-10%	-10%	-10%	-10%
Voltage tolerance Maximum	%	10%	10%	10%	10%	10%	10%
UNIT							
Maximum inrush current	A	0	0	0	0	0	0
Nominal running current cooling	A	101	104	172	177	177	208
Maximum running current	A	126	144	162	188	218	246
Maximum current for wires sizing	A	136	150	176	205	238	267
FANS							
Nominal running current cooling	A	11.2	11.2	11.2	11.2	14	16.8
COMPRESSORS							
Phases	No.	3	3	3	3	3	3
Voltage	V	400	400	400	400	400	400
Voltage tolerance Minimum	%	-10%	-10%	-10%	-10%	-10%	-10%
Voltage tolerance Maximum	%	10%	10%	10%	10%	10%	10%
Maximum running current	A	115	133	151	177	204	115
Starting method		INV	INV	INV	INV	INV	INV

MODEL		EWAD420TZ -PL B2	EWAD495TZ -PL B2	EWAD550TZ -PL B2	EWAD620TZ -PL B2	EWAD720TZ -PL B2	EWAD820TZ -PL B2
POWER SUPPLY							
Phases	No.	3	3	3	3	3	3
Frequency	Hz	50	50	50	50	50	50
Voltage	V	400	400	400	400	400	400
Voltage tolerance Minimum	%	-10%	-10%	-10%	-10%	-10%	-10%
Voltage tolerance Maximum	%	10%	10%	10%	10%	10%	10%
UNIT							
Maximum inrush current	A	0	0	0	0	0	0
Nominal running current cooling	A	211	346	258	298	316	375
Maximum running current	A	285	324	352	436	437	512
Maximum current for wires sizing	A	298	352	383	476	475	557
FANS							
Nominal running current cooling	A	19.6	22.4	25.2	28	28	30.8
COMPRESSORS							
Phases	No.	3	3	3	3	3	3
Voltage	V	400	400	400	400	400	400
Voltage tolerance Minimum	%	-10%	-10%	-10%	-10%	-10%	-10%
Voltage tolerance Maximum	%	10%	10%	10%	10%	10%	10%
Maximum running current	A	133	151	164	204	205	241
Starting method		INV	INV	INV	INV	INV	INV

Fluid: Water

Allowed voltage tolerance $\pm 10\%$. Voltage unbalance between phases must be within $\pm 3\%$.

Maximum starting current: In case of inverter driven units, no inrush current at start up is experienced.

Nominal current in cooling mode is referred to the following conditions: evaporator 12/7°C; ambient 35°C; compressors + fans current.

Maximum running current is based on max compressor absorbed current in its envelope and max fans absorbed current

Maximum unit current for wires sizing is based on minimum allowed voltage

Maximum current for wires sizing: (compressors full load ampere + fans current) x 1,1.

The data are referred to the standard unit without options.

For the electrical data of the hydronic kit refer to "Options technical data"

All data are subject to change without notice. Please refer to unit nameplate data.

EWAD~TZ-PL B

MODEL		EWAD950TZ -PL B2
POWER SUPPLY		
Phases	No.	3
Frequency	Hz	50
Voltage	V	400
Voltage tolerance Minimum	%	-10%
Voltage tolerance Maximum	%	10%
UNIT		
Maximum inrush current	A	0
Nominal running current cooling	A	424
Maximum running current	A	577
Maximum current for wires sizing	A	629
FANS		
Nominal running current cooling	A	33.6
COMPRESSORS		
Phases	No.	3
Voltage	V	400
Voltage tolerance Minimum	%	-10%
Voltage tolerance Maximum	%	10%
Maximum running current	A	272
Starting method		INV

Fluid: Water

Allowed voltage tolerance $\pm 10\%$. Voltage unbalance between phases must be within $\pm 3\%$.

Maximum starting current: In case of inverter driven units, no inrush current at start up is experienced.

Nominal current in cooling mode is referred to the following conditions: evaporator 12/7°C; ambient 35°C; compressors + fans current.

Maximum running current is based on max compressor absorbed current in its envelope and max fans absorbed current

Maximum unit current for wires sizing is based on minimum allowed voltage

Maximum current for wires sizing: (compressors full load ampere + fans current) $\times 1,1$.

The data are referred to the standard unit without options.

For the electrical data of the hydronic kit refer to "Options technical data"

All data are subject to change without notice. Please refer to unit nameplate data.

EWAD~TZ-PR B

MODEL		EWAD190TZ -PR B1	EWAD220TZ -PR B1	EWAD240TZ -PR B1	EWAD290TZ -PR B1	EWAD300TZ -PR B1	EWAD350TZ -PR B2
POWER SUPPLY							
Phases	No.	3	3	3	3	3	3
Frequency	Hz	50	50	50	50	50	50
Voltage	V	400	400	400	400	400	400
Voltage tolerance Minimum	%	-10%	-10%	-10%	-10%	-10%	-10%
Voltage tolerance Maximum	%	10%	10%	10%	10%	10%	10%
UNIT							
Maximum inrush current	A	0	0	0	0	0	0
Nominal running current cooling	A	101	104	172	177	177	209
Maximum running current	A	126	144	162	188	218	246
Maximum current for wires sizing	A	136	150	176	205	238	267
FANS							
Nominal running current cooling	A	11.2	11.2	11.2	11.2	14	16.8
COMPRESSORS							
Phases	No.	3	3	3	3	3	3
Voltage	V	400	400	400	400	400	400
Voltage tolerance Minimum	%	-10%	-10%	-10%	-10%	-10%	-10%
Voltage tolerance Maximum	%	10%	10%	10%	10%	10%	10%
Maximum running current	A	115	133	151	177	204	115
Starting method		INV	INV	INV	INV	INV	INV

MODEL		EWAD420TZ -PR B2	EWAD495TZ -PR B2	EWAD550TZ -PR B2	EWAD620TZ -PR B2	EWAD720TZ -PR B2	EWAD820TZ -PR B2
POWER SUPPLY							
Phases	No.	3	3	3	3	3	3
Frequency	Hz	50	50	50	50	50	50
Voltage	V	400	400	400	400	400	400
Voltage tolerance Minimum	%	-10%	-10%	-10%	-10%	-10%	-10%
Voltage tolerance Maximum	%	10%	10%	10%	10%	10%	10%
UNIT							
Maximum inrush current	A	0	0	0	0	0	0
Nominal running current cooling	A	212	347	259	300	317	377
Maximum running current	A	285	324	352	436	437	512
Maximum current for wires sizing	A	298	352	383	476	475	557
FANS							
Nominal running current cooling	A	19.6	22.4	25.2	28	28	30.8
COMPRESSORS							
Phases	No.	3	3	3	3	3	3
Voltage	V	400	400	400	400	400	400
Voltage tolerance Minimum	%	-10%	-10%	-10%	-10%	-10%	-10%
Voltage tolerance Maximum	%	10%	10%	10%	10%	10%	10%
Maximum running current	A	133	151	164	204	205	241
Starting method		INV	INV	INV	INV	INV	INV

Fluid: Water

Allowed voltage tolerance ± 10%. Voltage unbalance between phases must be within ± 3%.

Maximum starting current: In case of inverter driven units, no inrush current at start up is experienced.

Nominal current in cooling mode is referred to the following conditions: evaporator 12/7°C; ambient 35°C; compressors + fans current.

Maximum running current is based on max compressor absorbed current in its envelope and max fans absorbed current

Maximum unit current for wires sizing is based on minimum allowed voltage

Maximum current for wires sizing: (compressors full load ampere + fans current) x 1,1.

The data are referred to the standard unit without options.

For the electrical data of the hydronic kit refer to "Options technical data"

All data are subject to change without notice. Please refer to unit nameplate data.

EWAD~TZ-PR B

MODEL		EWAD950TZ -PR B2
POWER SUPPLY		
Phases	No.	3
Frequency	Hz	50
Voltage	V	400
Voltage tolerance Minimum	%	-10%
Voltage tolerance Maximum	%	10%
UNIT		
Maximum inrush current	A	0
Nominal running current cooling	A	426
Maximum running current	A	577
Maximum current for wires sizing	A	629
FANS		
Nominal running current cooling	A	33.6
COMPRESSORS		
Phases	No.	3
Voltage	V	400
Voltage tolerance Minimum	%	-10%
Voltage tolerance Maximum	%	10%
Maximum running current	A	272
Starting method		INV

Fluid: Water

Allowed voltage tolerance $\pm 10\%$. Voltage unbalance between phases must be within $\pm 3\%$.

Maximum starting current: In case of inverter driven units, no inrush current at start up is experienced.

Nominal current in cooling mode is referred to the following conditions: evaporator 12/7°C; ambient 35°C; compressors + fans current.

Maximum running current is based on max compressor absorbed current in its envelope and max fans absorbed current

Maximum unit current for wires sizing is based on minimum allowed voltage

Maximum current for wires sizing: (compressors full load ampere + fans current) $\times 1,1$.

The data are referred to the standard unit without options.

For the electrical data of the hydronic kit refer to "Options technical data"

All data are subject to change without notice. Please refer to unit nameplate data.

EWAD~TZ-SS B

MODEL	Sound pressure level at 1 m from the unit (rif. 2 x 10 ⁻⁵ Pa)								db(A)	Power db (A)
	63 Hz	125 Hz	250 Hz	500 Hz	1000 Hz	2000 Hz	4000 Hz	8000 Hz		
160	77.0	74.0	74.0	77.0	72.0	67.0	59.0	52.0	77	96
190	78.0	75.0	74.0	77.0	72.0	67.0	60.0	52.0	77	96
240	78.0	75.0	74.0	77.0	72.0	67.0	60.0	52.0	77	96
270	78.0	75.0	74.0	77.0	72.0	67.0	60.0	52.0	77	97
300	79.0	76.0	75.0	78.0	73.0	68.0	61.0	53.0	78	98
360	80.0	77.0	76.0	79.0	74.0	69.0	62.0	54.0	79	99
380	80.0	77.0	76.0	79.0	74.0	69.0	62.0	54.0	79	99
450	80.0	77.0	76.0	79.0	74.0	69.0	62.0	54.0	79	99
495	79.0	76.0	76.0	79.0	74.0	69.0	61.0	54.0	79	99
570	80.0	77.0	77.0	79.0	74.0	70.0	62.0	54.0	80	100
610	80.0	77.0	77.0	80.0	75.0	70.0	62.0	55.0	80	101
660	82.0	79.0	79.0	81.0	76.0	72.0	64.0	56.0	82	102
700	84.0	81.0	81.0	84.0	78.0	74.0	66.0	59.0	84	105
820	74.0	67.0	68.0	80.0	78.0	68.0	56.0	54.0	81	102
900	74.0	67.0	68.0	80.0	78.0	68.0	56.0	54.0	81	102
990	74.0	67.0	68.0	80.0	78.0	68.0	56.0	54.0	81	102
C10	73.0	66.0	64.0	82.0	76.0	68.0	56.0	52.0	81	103
C11	74.0	68.0	67.0	73.0	76.0	77.0	60.0	56.0	81	103

Sound power level (referred to evaporator 12/7°C, ambient 35°C full load operation) are measured in accordance with ISO 9614 and Eurovent 8/1 for Eurovent certified units. The certification refers only to the overall sound power level. The sound data in the Octave band spectrum is for intended for reference only and not considering binding. The sound pressure is calculated from the sound power level and are for information only and not considered binding.

EWAD~TZ-SL B

MODEL	Sound pressure level at 1 m from the unit (rif. 2 x 10⁻⁵ Pa)								Power db (A)	
	63 Hz	125 Hz	250 Hz	500 Hz	1000 Hz	2000 Hz	4000 Hz	8000 Hz	db(A)	(A)
160	71.0	68.0	68.0	71.0	66.0	61.0	53.0	46.0	71	90
190	72.0	69.0	69.0	71.0	66.0	62.0	54.0	46.0	72	90.5
240	72.0	69.0	69.0	71.0	66.0	62.0	54.0	46.0	72	90.5
270	72.0	69.0	69.0	72.0	67.0	62.0	54.0	47.0	72	91.5
300	73.0	70.0	70.0	73.0	68.0	63.0	55.0	48.0	73	92.5
360	74.0	71.0	71.0	73.0	68.0	64.0	56.0	48.0	74	93.5
380	74.0	71.0	71.0	73.0	68.0	64.0	56.0	48.0	74	93.5
450	74.0	71.0	71.0	73.0	68.0	64.0	56.0	48.0	74	93.5
495	74.0	71.0	71.0	73.0	68.0	64.0	56.0	48.0	74	94
570	74.0	71.0	71.0	74.0	68.0	64.0	56.0	49.0	74	94.5
610	75.0	72.0	72.0	75.0	69.0	65.0	57.0	50.0	75	95.5
660	76.0	73.0	73.0	76.0	70.0	66.0	58.0	51.0	76	96.5
700	78.0	75.0	75.0	77.0	72.0	68.0	60.0	52.0	77	98.5
820	71.0	64.0	65.0	77.0	75.0	65.0	53.0	51.0	78	99
900	71.0	64.0	65.0	77.0	75.0	65.0	53.0	51.0	78	99
990	71.0	64.0	65.0	77.0	75.0	65.0	53.0	51.0	78	99
C10	70.0	63.0	61.0	79.0	73.0	65.0	54.0	50.0	78	100
C11	71.0	65.0	64.0	70.0	73.0	74.0	57.0	53.0	78	100

Sound power level (referred to evaporator 12/7°C, ambient 35°C full load operation) are measured in accordance with ISO 9614 and Eurovent 8/1 for Eurovent certified units. The certification refers only to the overall sound power level. The sound data in the Octave band spectrum is for intended for reference only and not considering binding. The sound pressure is calculated from the sound power level and are for information only and not considered binding.

EWAD~TZ-SR B

MODEL	Sound pressure level at 1 m from the unit (rif. 2×10^{-5} Pa)								db(A)	Power db (A)
	63 Hz	125 Hz	250 Hz	500 Hz	1000 Hz	2000 Hz	4000 Hz	8000 Hz		
160	67.0	64.0	64.0	67.0	62.0	57.0	49.0	42.0	67	86
190	68.0	65.0	65.0	67.0	62.0	58.0	50.0	42.0	68	87
240	68.0	65.0	65.0	67.0	62.0	58.0	50.0	42.0	68	87
270	68.0	65.0	65.0	68.0	63.0	58.0	50.0	43.0	68	88
300	69.0	66.0	66.0	68.0	63.0	59.0	51.0	43.0	69	88
360	70.0	67.0	67.0	69.0	64.0	60.0	52.0	44.0	70	90
380	70.0	67.0	67.0	69.0	64.0	60.0	52.0	44.0	70	90
450	70.0	67.0	67.0	69.0	64.0	60.0	52.0	44.0	70	90
495	70.0	67.0	67.0	69.0	64.0	60.0	52.0	44.0	70	90
570	70.0	67.0	67.0	70.0	65.0	60.0	52.0	45.0	70	91
610	70.0	67.0	67.0	70.0	65.0	60.0	52.0	45.0	70	91
660	71.0	68.0	68.0	71.0	66.0	61.0	53.0	46.0	71	92
700	73.0	70.0	70.0	73.0	68.0	63.0	55.0	48.0	73	94
820	66.0	59.0	60.0	72.0	70.0	59.0	48.0	46.0	73	94.1
900	66.0	59.0	60.0	72.0	70.0	59.0	48.0	46.0	73	94.1
990	66.0	59.0	60.0	72.0	70.0	60.0	48.0	46.0	73	94.5
C10	65.0	58.0	56.0	74.0	68.0	60.0	49.0	44.0	73	94.8
C11	66.0	60.0	59.0	65.0	68.0	69.0	52.0	48.0	73	95.2

Sound power level (referred to evaporator 12/7°C, ambient 35°C full load operation) are measured in accordance with ISO 9614 and Eurovent 8/1 for Eurovent certified units. The certification refers only to the overall sound power level. The sound data in the Octave band spectrum is for intended for reference only and not considering binding. The sound pressure is calculated from the sound power level and are for information only and not considered binding.

EWAD~TZ-XS B

MODEL	Sound pressure level at 1 m from the unit (rif. 2×10^{-5} Pa)								Power db (A)	
	63 Hz	125 Hz	250 Hz	500 Hz	1000 Hz	2000 Hz	4000 Hz	8000 Hz	db(A)	(A)
190	77.0	74.0	74.0	77.0	72.0	67.0	59.0	52.0	77	96
220	78.0	75.0	75.0	77.0	72.0	68.0	60.0	52.0	77	97
240	77.0	74.0	74.0	77.0	72.0	67.0	59.0	52.0	77	96
290	77.0	74.0	74.0	77.0	72.0	67.0	59.0	52.0	77	97
320	78.0	75.0	75.0	78.0	73.0	68.0	60.0	53.0	78	98
360	79.0	76.0	76.0	79.0	74.0	69.0	61.0	54.0	79	99
420	79.0	76.0	76.0	79.0	74.0	69.0	61.0	54.0	79	99
450	79.0	76.0	76.0	78.0	73.0	69.0	61.0	53.0	79	99
540	79.0	76.0	76.0	78.0	73.0	69.0	61.0	53.0	79	99
570	79.0	76.0	76.0	79.0	74.0	69.0	61.0	54.0	79	100
610	80.0	77.0	76.0	79.0	74.0	69.0	62.0	54.0	79	100
660	80.0	77.0	77.0	79.0	74.0	70.0	62.0	54.0	80	101
680	80.0	77.0	77.0	79.0	74.0	70.0	62.0	54.0	80	101
770	77.0	69.0	77.0	79.0	76.0	69.0	55.0	54.0	80	101
850	74.0	66.0	67.0	79.0	77.0	67.0	55.0	53.0	80	101
910	73.0	66.0	66.0	79.0	76.0	66.0	55.0	52.0	79	101
C10	73.0	66.0	66.0	79.0	76.0	66.0	55.0	53.0	79	101
C11	72.0	65.0	63.0	80.0	74.0	67.0	55.0	51.0	79	102

Sound power level (referred to evaporator 12/7°C, ambient 35°C full load operation) are measured in accordance with ISO 9614 and Eurovent 8/1 for Eurovent certified units. The certification refers only to the overall sound power level. The sound data in the Octave band spectrum is for intended for reference only and not considering binding. The sound pressure is calculated from the sound power level and are for information only and not considered binding.

EWAD~TZ-XL B

MODEL	Sound pressure level at 1 m from the unit (rif. 2 x 10 ⁻⁵ Pa)								Power db (A)	
	63 Hz	125 Hz	250 Hz	500 Hz	1000 Hz	2000 Hz	4000 Hz	8000 Hz	db(A)	(A)
190	72.0	69.0	69.0	71.0	66.0	62.0	54.0	46.0	72	91
220	72.0	69.0	69.0	72.0	67.0	62.0	54.0	47.0	72	91.5
240	72.0	69.0	69.0	71.0	66.0	62.0	54.0	46.0	72	91
290	72.0	69.0	69.0	71.0	66.0	62.0	54.0	46.0	72	91.5
320	73.0	70.0	70.0	72.0	67.0	63.0	55.0	47.0	73	92.5
360	73.0	70.0	70.0	73.0	68.0	63.0	55.0	48.0	73	93.5
420	74.0	71.0	71.0	73.0	68.0	64.0	56.0	48.0	74	94
450	73.0	70.0	70.0	73.0	68.0	63.0	55.0	48.0	73	94
540	73.0	70.0	70.0	73.0	68.0	63.0	55.0	48.0	73	94
570	74.0	71.0	71.0	74.0	68.0	64.0	56.0	49.0	74	94.5
610	74.0	71.0	71.0	74.0	69.0	64.0	56.0	49.0	74	95
660	74.0	71.0	71.0	74.0	69.0	64.0	56.0	49.0	74	95.5
680	74.0	71.0	71.0	74.0	69.0	64.0	56.0	49.0	74	95.5
770	73.0	65.0	72.0	74.0	72.0	64.0	51.0	50.0	75	97
850	69.0	62.0	62.0	75.0	72.0	62.0	51.0	49.0	75	97
910	69.0	61.0	62.0	75.0	72.0	62.0	50.0	48.0	75	97
C10	69.0	62.0	62.0	75.0	72.0	62.0	50.0	48.0	75	97
C11	67.0	60.0	58.0	76.0	70.0	63.0	51.0	47.0	75	97

Sound power level (referred to evaporator 12/7°C, ambient 35°C full load operation) are measured in accordance with ISO 9614 and Eurovent 8/1 for Eurovent certified units. The certification refers only to the overall sound power level. The sound data in the Octave band spectrum is for intended for reference only and not considering binding. The sound pressure is calculated from the sound power level and are for information only and not considered binding.

EWAD~TZ-XR B

MODEL	Sound pressure level at 1 m from the unit (rif. 2×10^{-5} Pa)								Power db (A)	
	63 Hz	125 Hz	250 Hz	500 Hz	1000 Hz	2000 Hz	4000 Hz	8000 Hz	db(A)	(A)
190	68.0	65.0	65.0	68.0	63.0	58.0	50.0	43.0	68	88
220	68.0	65.0	65.0	68.0	63.0	58.0	50.0	43.0	68	88
240	68.0	65.0	65.0	68.0	63.0	58.0	50.0	43.0	68	88
290	69.0	66.0	66.0	68.0	63.0	59.0	51.0	43.0	69	89
320	69.0	66.0	66.0	69.0	64.0	59.0	51.0	44.0	69	89
360	70.0	67.0	67.0	69.0	64.0	60.0	52.0	44.0	70	90
420	70.0	67.0	67.0	69.0	64.0	60.0	52.0	44.0	70	90
450	70.0	67.0	67.0	70.0	64.0	60.0	52.0	45.0	70	91
540	70.0	67.0	67.0	70.0	64.0	60.0	52.0	45.0	70	91
570	70.0	67.0	67.0	70.0	64.0	60.0	52.0	45.0	70	91
610	70.0	67.0	67.0	70.0	65.0	60.0	52.0	45.0	70	91
660	71.0	68.0	68.0	70.0	65.0	61.0	53.0	45.0	71	92
680	71.0	68.0	68.0	70.0	65.0	61.0	53.0	45.0	71	92
770	70.0	62.0	70.0	72.0	69.0	62.0	49.0	48.0	73	94
850	67.0	60.0	60.0	73.0	70.0	60.0	48.0	46.0	73	94
910	66.0	59.0	60.0	72.0	70.0	60.0	48.0	46.0	73	95
C10	66.0	59.0	60.0	72.0	70.0	60.0	48.0	46.0	73	95
C11	65.0	58.0	56.0	74.0	68.0	61.0	49.0	45.0	73	95

Sound power level (referred to evaporator 12/7°C, ambient 35°C full load operation) are measured in accordance with ISO 9614 and Eurovent 8/1 for Eurovent certified units. The certification refers only to the overall sound power level. The sound data in the Octave band spectrum is for intended for reference only and not considering binding. The sound pressure is calculated from the sound power level and are for information only and not considered binding.

EWAD~TZ-PS B

MODEL	Sound pressure level at 1 m from the unit (rif. 2×10^{-5} Pa)								Power db (A)	
	63 Hz	125 Hz	250 Hz	500 Hz	1000 Hz	2000 Hz	4000 Hz	8000 Hz	db(A)	(A)
190	77.0	74.0	74.0	76.0	71.0	67.0	59.0	51.0	77	97
220	77.0	74.0	74.0	77.0	72.0	67.0	59.0	52.0	77	97
240	77.0	74.0	74.0	76.0	71.0	67.0	59.0	51.0	77	97
290	77.0	74.0	74.0	77.0	72.0	67.0	59.0	52.0	77	97
300	77.0	74.0	74.0	77.0	72.0	67.0	59.0	52.0	77	98
350	78.0	75.0	75.0	78.0	73.0	68.0	60.0	53.0	78	99
420	78.0	75.0	75.0	77.0	72.0	68.0	60.0	52.0	77	99
495	78.0	75.0	75.0	78.0	73.0	68.0	60.0	53.0	78	100
550	77.0	69.0	76.0	78.0	76.0	68.0	55.0	54.0	79	101
620	73.0	66.0	66.0	79.0	76.0	66.0	55.0	53.0	79	101
720	76.0	68.0	76.0	78.0	75.0	68.0	55.0	54.0	79	101
820	73.0	65.0	66.0	78.0	76.0	66.0	54.0	52.0	79	101
950	72.0	65.0	66.0	78.0	76.0	66.0	54.0	52.0	79	101

Sound power level (referred to evaporator 12/7°C, ambient 35°C full load operation) are measured in accordance with ISO 9614 and Eurovent 8/1 for Eurovent certified units. The certification refers only to the overall sound power level. The sound data in the Octave band spectrum is for intended for reference only and not considering binding. The sound pressure is calculated from the sound power level and are for information only and not considered binding.

EWAD~TZ-PL B

MODEL	Sound pressure level at 1 m from the unit (rif. 2 x 10⁻⁵ Pa)								Power db (A)	
	63 Hz	125 Hz	250 Hz	500 Hz	1000 Hz	2000 Hz	4000 Hz	8000 Hz	db(A)	(A)
190	71.0	68.0	68.0	71.0	66.0	61.0	53.0	46.0	71	91
220	72.0	69.0	69.0	71.0	66.0	62.0	54.0	46.0	72	91.5
240	71.0	68.0	68.0	71.0	66.0	61.0	53.0	46.0	71	91
290	72.0	69.0	69.0	71.0	66.0	62.0	54.0	46.0	72	91.5
300	72.0	69.0	69.0	71.0	66.0	62.0	54.0	46.0	72	92
350	73.0	70.0	70.0	73.0	67.0	63.0	55.0	48.0	73	93.5
420	73.0	70.0	70.0	72.0	67.0	63.0	55.0	47.0	72	93.5
495	73.0	70.0	70.0	72.0	67.0	63.0	55.0	47.0	73	94
550	72.0	64.0	72.0	74.0	71.0	64.0	51.0	50.0	75	97
620	69.0	62.0	62.0	75.0	72.0	62.0	50.0	48.0	75	97
720	72.0	64.0	72.0	74.0	71.0	63.0	50.0	49.0	75	97
820	68.0	61.0	62.0	74.0	72.0	61.0	50.0	48.0	75	97
950	68.0	61.0	61.0	74.0	71.0	61.0	50.0	48.0	75	97

Sound power level (referred to evaporator 12/7°C, ambient 35°C full load operation) are measured in accordance with ISO 9614 and Eurovent 8/1 for Eurovent certified units. The certification refers only to the overall sound power level. The sound data in the Octave band spectrum is for intended for reference only and not considering binding. The sound pressure is calculated from the sound power level and are for information only and not considered binding.

EWAD~TZ-PR B

MODEL	Sound pressure level at 1 m from the unit (rif. 2×10^{-5} Pa)								Power db (A)	
	63 Hz	125 Hz	250 Hz	500 Hz	1000 Hz	2000 Hz	4000 Hz	8000 Hz	db(A)	(A)
190	67.0	64.0	64.0	67.0	62.0	57.0	49.0	42.0	67	87
220	68.0	65.0	65.0	67.0	62.0	58.0	50.0	42.0	68	88
240	67.0	64.0	64.0	67.0	62.0	57.0	49.0	42.0	67	87
290	68.0	65.0	65.0	67.0	62.0	58.0	50.0	42.0	68	88
300	68.0	65.0	65.0	67.0	62.0	58.0	50.0	42.0	68	88
350	68.0	65.0	65.0	68.0	63.0	58.0	50.0	43.0	68	89
420	69.0	66.0	66.0	68.0	63.0	59.0	51.0	43.0	68	90
495	69.0	66.0	66.0	68.0	63.0	59.0	51.0	43.0	69	90
550	70.0	62.0	70.0	72.0	69.0	62.0	48.0	47.0	73	94
620	66.0	59.0	60.0	72.0	70.0	60.0	48.0	46.0	73	95
720	70.0	62.0	70.0	72.0	69.0	61.0	48.0	47.0	73	95
820	66.0	59.0	60.0	72.0	70.0	59.0	48.0	46.0	73	95
950	66.0	59.0	60.0	72.0	70.0	59.0	48.0	46.0	73	95

Sound power level (referred to evaporator 12/7°C, ambient 35°C full load operation) are measured in accordance with ISO 9614 and Eurovent 8/1 for Eurovent certified units. The certification refers only to the overall sound power level. The sound data in the Octave band spectrum is for intended for reference only and not considering binding. The sound pressure is calculated from the sound power level and are for information only and not considered binding.

**Operating limits
EWAD~TZ S-B- (SILVER SERIES) size 160 - 700**

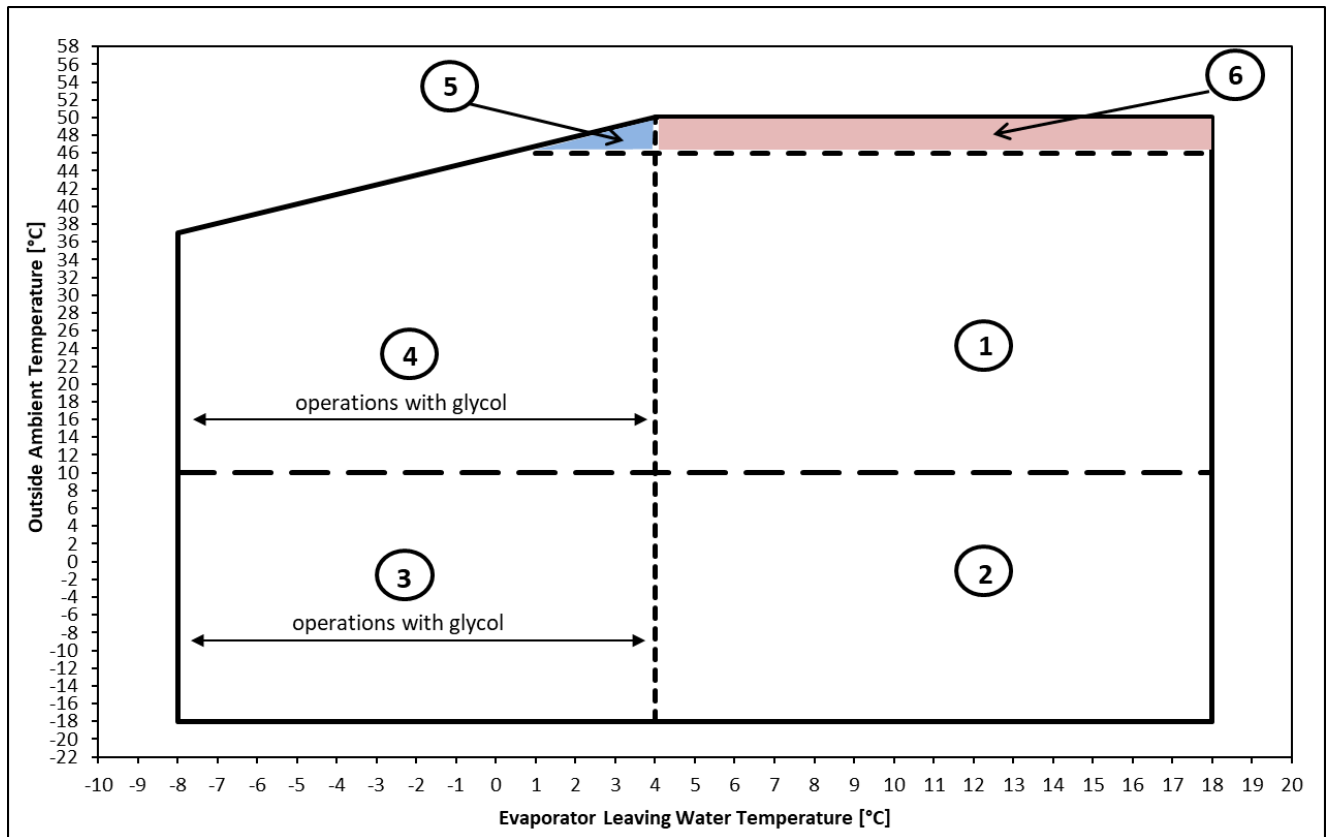

In order to operate the following options must be included according to the specific operating area:

Ref.1: standard unit (no option are required to operate in this area)

Ref.2: standard unit + {
Opt. 42 – (SPEEDTROL)
Opt. 99a – (FANS SPEED REGULATION)
Opt. 159 – (EC MOTOR FANS)

Ref.3: standard unit + opt. 08 (Brine) {
Opt. 42 – (SPEEDTROL)
Opt. 99a – (FANS SPEED REGULATION)
Opt. 159 – (EC MOTOR FANS)

Ref.4: standard unit + opt. 08 (Brine) (chiller may not unload to minimum load)

Ref.5: contact factory

Ref.6: standard unit + opt. 142 (HIGH AMBIENT KIT)

NOTE:

- The above graph refers to the unit operating at full load. Unit may be able to operate outside the above envelope with compressors unloading. Please contact factory for further details.
- For operation with EWLT below 4°C, the unit must operate with glycol mixture. The glycol percentage must be provide according to the minimum ELWT needed.
- The above graphic represents a guideline about the operating limits of the range. Please refer to the latest Chiller Selection Software (CSS) for real operating limits working conditions for each size.
- Opt. 142 provides 6 poles fans (running 900 RPM). The performances will differ from the standards.
- Opt. 159 provides EC motors fans. The performances will differ from the standards.
- For units equipped with opt. 142 the sound performances are different from the standards.
- In area 3 and 4 chiller may not unload to the minimum load

EWAD~TZ S-B- (SILVER SERIES) size 820 - C11

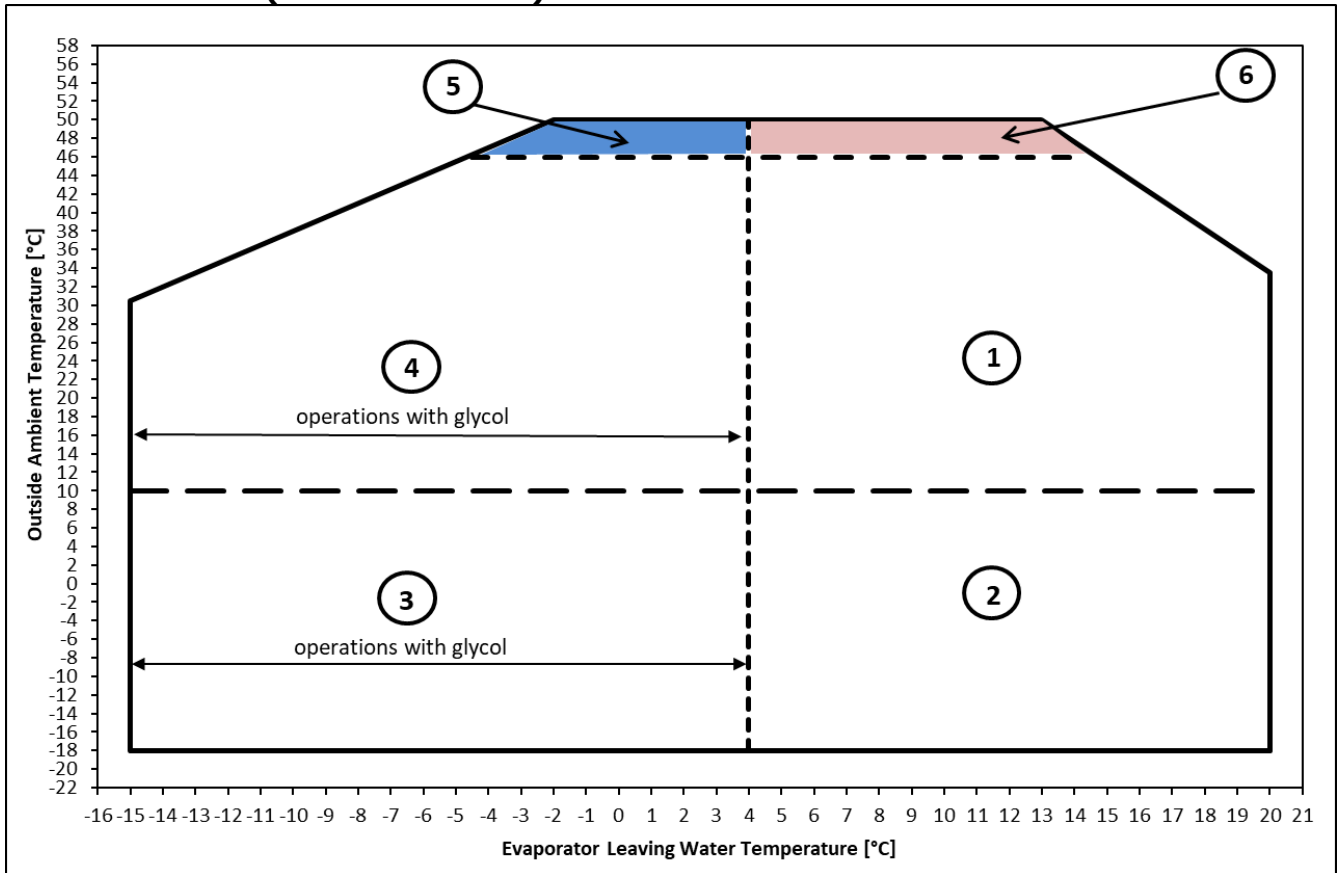

In order to operate the following options must be included according to the specific operating area:

Ref.1: standard unit (no option are required to operate in this area)

Ref.2: standard unit + {
 Opt. 42 – (SPEEDTROL)
 Opt. 99a – (FANS SPEED REGULATION)
 Opt. 158 – (EC MOTOR FANS)

Ref.3: standard unit + opt. 08 (Brine) {
 Opt. 42 – (SPEEDTROL)
 Opt. 99a – (FANS SPEED REGULATION)
 Opt. 158 – (EC MOTOR FANS)

Ref.4: standard unit + opt. 08 (Brine) (chiller may not unload to minimum load)

Ref.5: contact factory

Ref.6: standard unit + opt. 142 (HIGH AMBIENT KIT)

NOTE:

- The above graph refers to the unit operating at full load. Unit may be able to operate outside the above envelope with compressors unloading. Please contact factory for further details.
- For operation with EWLT below 4°C, the unit must operate with glycol mixture. The glycol percentage must be provide according to the minimum ELWT needed.
- The above graphic represents a guideline about the operating limits of the range. Please refer to the latest Chiller Selection Software (CSS) for real operating limits working conditions for each size.
- Opt. 158 provides EC motors fans. The performances will differ from the standards.
- In area 3 and 4 chiller may not unload to the minimum load

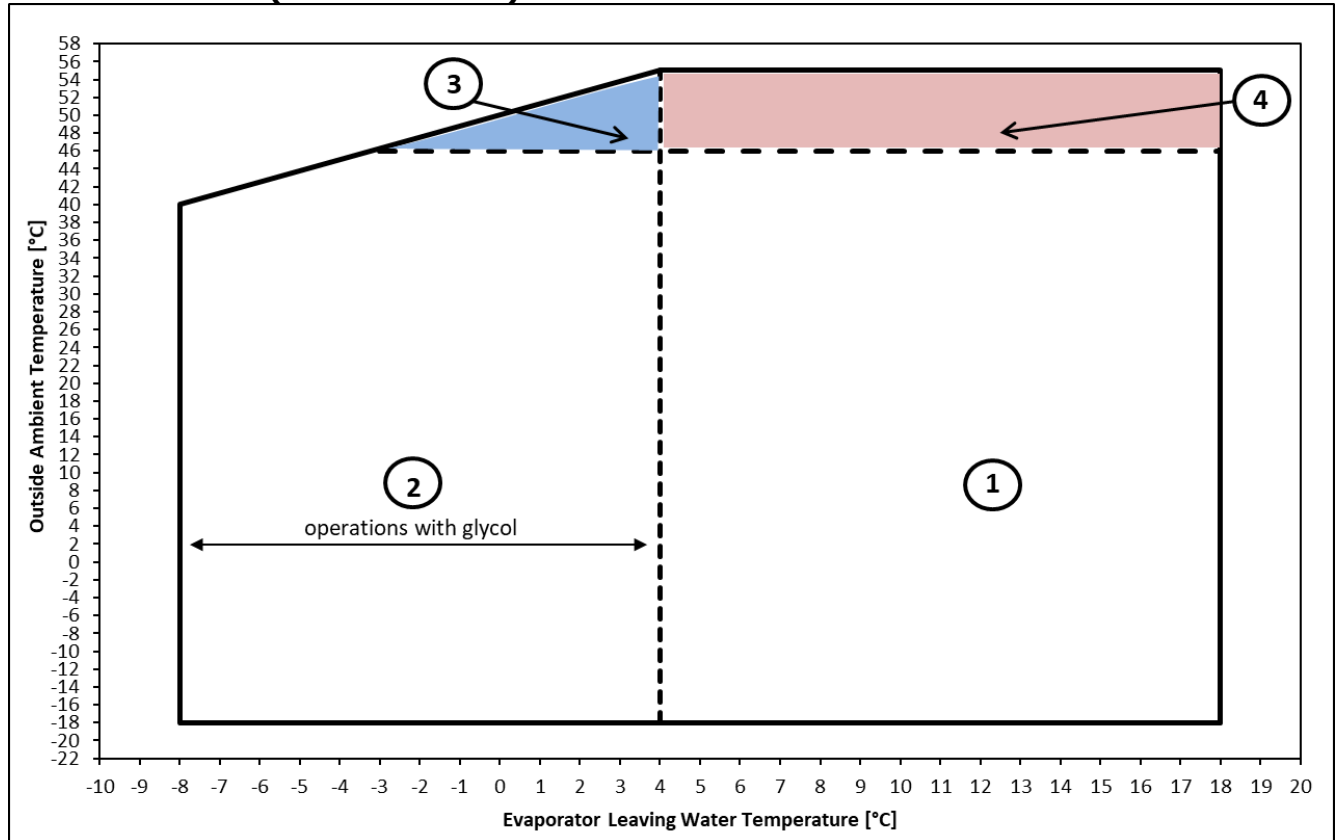
EWAD~TZ X-B- (GOLD SERIES) size 190 - 680

In order to operate the following options must be included according to the specific operating area:

Ref. 1: standard unit (no options are required to operate in this area)

Ref. 2: standard unit + opt. 08 (Brine) (chiller may not unload to minimum load)

Ref. 3: contact factory

Ref. 4: standard unit + opt. 142 (HIGH AMBIENT KIT)

NOTE:

- The above graph refers to the unit operating at full load. Unit may be able to operate outside the above envelope with compressors unloading. Please contact factory for further details.
- For operation with EWLT below 4°C, the unit must operate with glycol mixture. The glycol percentage must be provide according to the minimum ELWT needed.
- The above graphic represents a guideline about the operating limits of the range. Please refer to the latest Chiller Selection Software (CSS) for real operating limits working conditions for each size.
- Opt. 142 provides EC motors fans. The performances will differ from the standards.
- In area 2 and 3 chiller may not unload to the minimum load

EWAD~TZ X-B- (GOLD SERIES) size 770 – C11

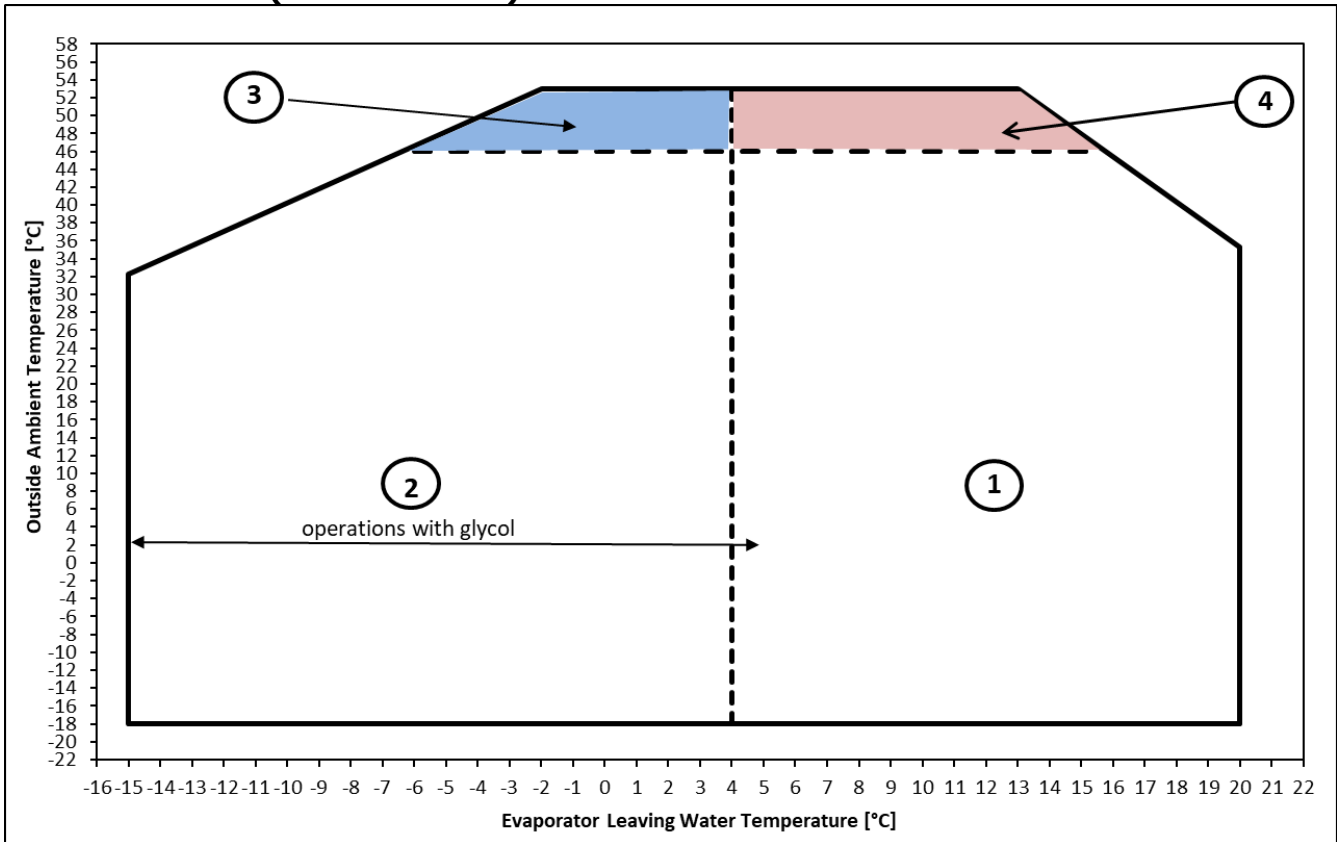

In order to operate the following options must be included according to the specific operating area:

Ref. 1: standard unit (no options are required to operate in this area)

Ref. 2: standard unit + opt. 08 (Brine) (chiller may not unload to minimum load)

Ref. 3: contact factory

Ref. 4: standard unit + opt. 142 (HIGH AMBIENT KIT)

NOTE:

- The above graph refers to the unit operating at full load. Unit may be able to operate outside the above envelope with compressors unloading. Please contact factory for further details.
- For operation with EWLT below 4°C, the unit must operate with glycol mixture. The glycol percentage must be provide according to the minimum ELWT needed.
- The above graphic represents a guideline about the operating limits of the range. Please refer to the latest Chiller Selection Software (CSS) for real operating limits working conditions for each size.
- Opt. 142 provides EC motors fans. The performances will differ from the standards.
- In area 2 and 3 chiller may not unload to the minimum load

EWAD~TZ P-B- (PLATINUM SERIES) size 190 - 620

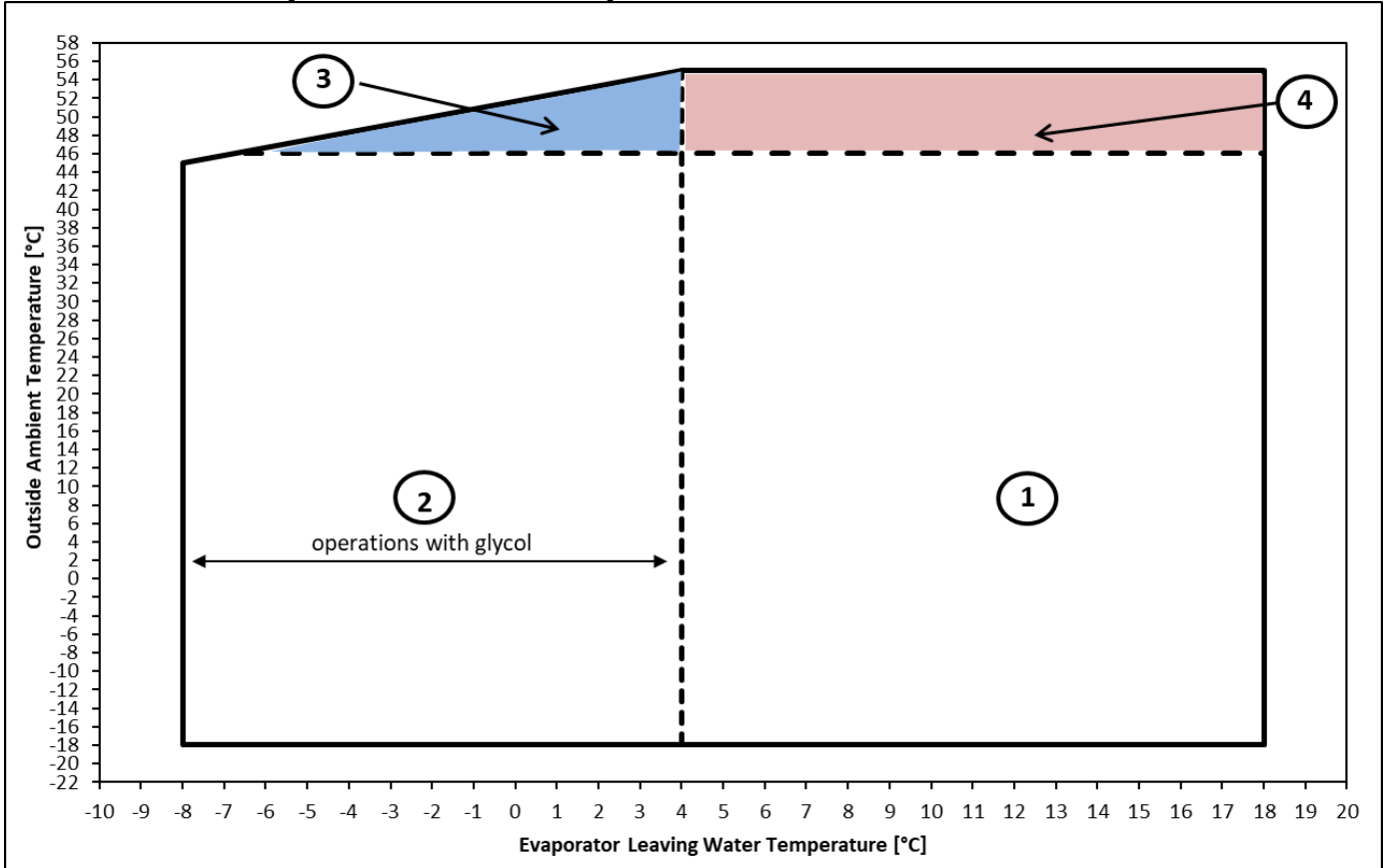

In order to operate the following options must be included according to the specific operating area:

- Ref. 1: standard unit** (no options are required to operate in this area)
- Ref. 2: standard unit + opt. 08 (Brine)** (chiller may not unload to minimum load)
- Ref. 3: contact factory**
- Ref. 4: standard unit + opt. 142 (HIGH AMBIENT KIT)**

NOTE:

- The above graph refers to the unit operating at full load. Unit may be able to operate outside the above envelope with compressors unloading. Please contact factory for further details.
- For operation with EWLT below 4°C, the unit must operate with glycol mixture. The glycol percentage must be provide according to the minimum ELWT needed.
- The above graphic represents a guideline about the operating limits of the range. Please refer to the latest Chiller Selection Software (CSS) for real operating limits working conditions for each size.
- In area 2 and 3 chiller may not unload to the minimum load

EWAD~TZ P-B- (PLATINUM SERIES) size 720 - 950

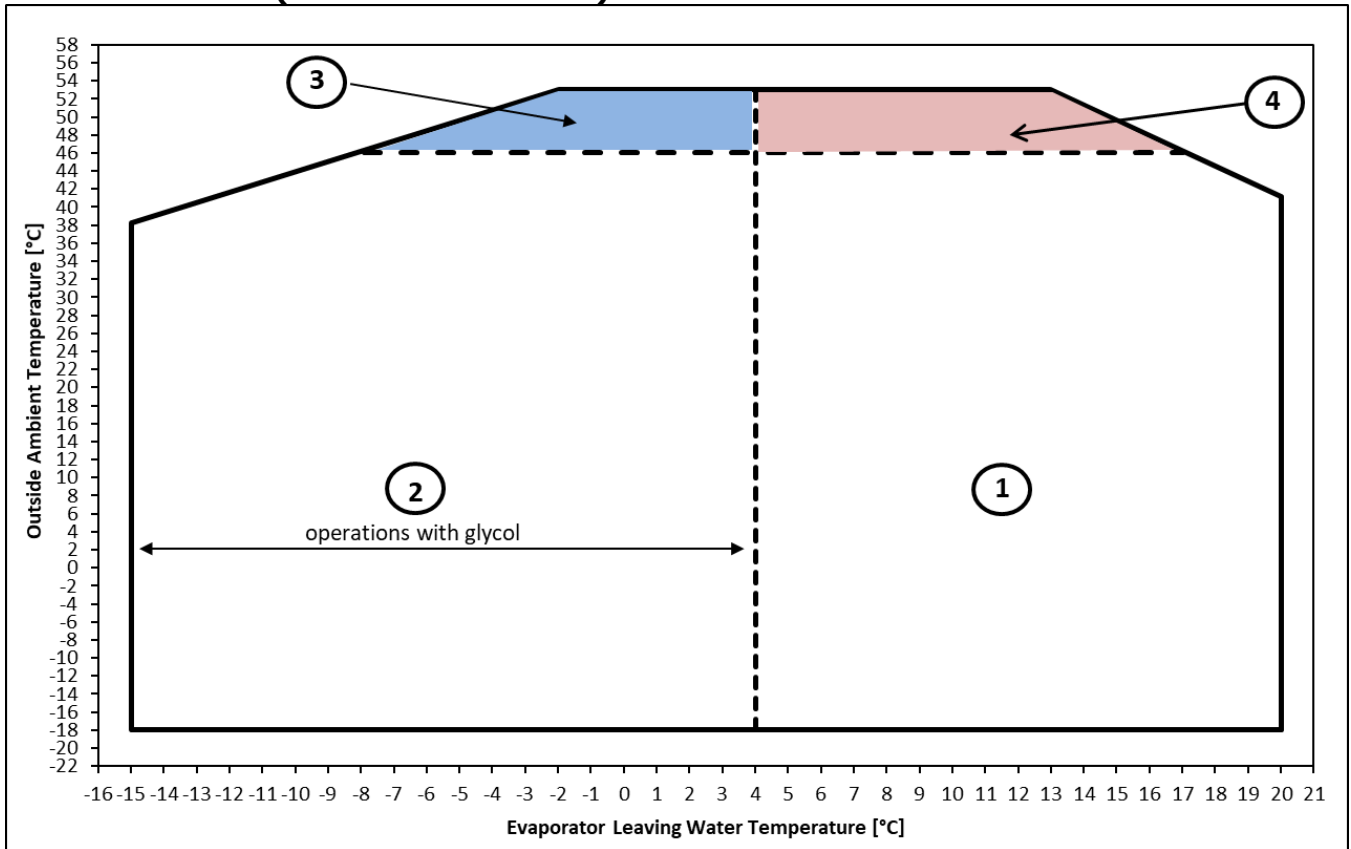

In order to operate the following options must be included according to the specific operating area:

- Ref. 1: standard unit** (no options are required to operate in this area)
- Ref. 2: standard unit + opt. 08 (Brine)** (chiller may not unload to minimum load)
- Ref. 3: contact factory**
- Ref. 4: standard unit + opt. 142 (HIGH AMBIENT KIT)**

NOTE:

- The above graph refers to the unit operating at full load. Unit may be able to operate outside the above envelope with compressors unloading. Please contact factory for further details.
- For operation with EWLT below 4°C, the unit must operate with glycol mixture. The glycol percentage must be provide according to the minimum ELWT needed.
- The above graphic represents a guideline about the operating limits of the range. Please refer to the latest Chiller Selection Software (CSS) for real operating limits working conditions for each size.
- In area 2 chiller may not unload to the minimum load

Minimum water flow

In the following tables are indicated the minimum water flow allowed for each model. For application with Variable Primary Flow (opt. code 143) refer to the following value for the dimensioning of the bypass line.

In case of variable flow application where the speed of the pump is managed by an external BMS (through 0- 10V signal) the change in water flow rate must not be exceeded more than 10% of design water flow rate (at standard conditions) per minute.

The minimum flow indicated correspond to the minimum flow allowed at minimum load for the unit. It is not intended as minimum flow allowed for unit full load operation.

For minimum flow allowed (maximum ΔT) in full load operation refer to Selection Software.

The below values are referred to pure water (in case of glycol mixture contact factory).

Note: the performance are certified at standard conditions and with the unit operating with the nominal water flow (corresponding to OAT 35°C; water in/out 12/7°C)

Unit model			water flow [l/s]	
Standard sound	Low Sound	Reduced Sound	min	
SILVER	EWAD160TZSSB1	EWAD160TZSLB1	EWAD160TZSRB1	3,8
	EWAD190TZSSB1	EWAD190TZSLB1	EWAD190TZSRB1	4,8
	EWAD240TZSSB1	EWAD240TZSLB1	EWAD240TZSRB1	6,9
	EWAD270TZSSB1	EWAD270TZSLB1	EWAD270TZSRB1	4,8
	EWAD300TZSSB1	EWAD300TZSLB1	EWAD300TZSRB1	6,9
	EWAD360TZSSB1	EWAD360TZSLB1	EWAD360TZSRB1	8,3
	EWAD380TZSSB2	EWAD380TZSLB2	EWAD380TZSRB2	7,5
	EWAD450TZSSB2	EWAD450TZSLB2	EWAD450TZSRB2	9,4
	EWAD495TZSSB2	EWAD495TZSLB2	EWAD495TZSRB2	7,5
	EWAD570TZSSB2	EWAD570TZSLB2	EWAD570TZSRB2	7,5
	EWAD610TZSSB2	EWAD610TZSLB2	EWAD610TZSRB2	9,4
	EWAD660TZSSB2	EWAD660TZSLB2	EWAD660TZSRB2	9,4
	EWAD700TZSSB2	EWAD700TZSLB2	EWAD700TZSRB2	9,4
	EWAD820TZSSB2	EWAD820TZSLB2	EWAD820TZSRB2	13
	EWAD900TZSSB2	EWAD900TZSLB2	EWAD900TZSRB2	15
	EWAD990TZSSB2	EWAD990TZSLB2	EWAD990TZSRB2	15
	EWADC10TZSSB2	EWADC10TZSLB2	EWADC10TZSRB2	15
	EWADC11TZSSB2	EWADC11TZSLB2	EWADC11TZSRB2	21

	Unit model			water flow [l/s]
	Standard sound	Low Sound	Reduced Sound	min
	GOLD	EWAD190TZXS1	EWAD190TZXL1	EWAD190TZXR1
EWAD220TZXS1		EWAD220TZXL1	EWAD220TZXR1	6,9
EWAD240TZXS1		EWAD240TZXL1	EWAD240TZXR1	6,9
EWAD290TZXS1		EWAD290TZXL1	EWAD290TZXR1	8,3
EWAD320TZXS1		EWAD320TZXL1	EWAD320TZXR1	8,3
EWAD360TZXS2		EWAD360TZXL2	EWAD360TZXR2	7,5
EWAD420TZXS2		EWAD420TZXL2	EWAD420TZXR2	7,5
EWAD440TZXS2		EWAD440TZXL2	EWAD440TZXR2	7,5
EWAD450TZXS2		EWAD450TZXL2	EWAD450TZXR2	7,5
EWAD540TZXS2		EWAD540TZXL2	EWAD540TZXR2	9,4
EWAD570TZXS2		EWAD570TZXL2	EWAD570TZXR2	9,4
EWAD610TZXS2		EWAD610TZXL2	EWAD610TZXR2	9,4
EWAD660TZXS2		EWAD660TZXL2	EWAD660TZXR2	9,4
EWAD680TZXS2		EWAD680TZXL2	EWAD680TZXR2	9,4
EWAD770TZXS2		EWAD770TZXL2	EWAD770TZXR2	13
EWAD850TZXS2		EWAD850TZXL2	EWAD850TZXR2	15
EWAD910TZXS2		EWAD910TZXL2	EWAD910TZXR2	15
EWADC10TZXS2		EWADC10TZXL2	EWADC10TZXR2	15
EWADC11TZXS2	EWADC11TZXL2	EWADC11TZXR2	21	

	Unit model			water flow [l/s]
	Standard sound	Low Sound	Reduced Sound	min
	PLATINUM	EWAD190TZPS1	EWAD190TZPL1	EWAD190TZPR1
EWAD220TZPS1		EWAD220TZPL1	EWAD220TZPR1	8,3
EWAD240TZPS1		EWAD240TZPL1	EWAD240TZPR1	8,3
EWAD290TZPS1		EWAD290TZPL1	EWAD290TZPR1	8,3
EWAD300TZPS1		EWAD300TZPL1	EWAD300TZPR1	8,3
EWAD350TZPS2		EWAD350TZPL2	EWAD350TZPR2	9,4
EWAD420TZPS2		EWAD420TZPL2	EWAD420TZPR2	9,4
EWAD495TZPS2		EWAD495TZPL2	EWAD495TZPR2	9,4
EWAD550TZPS2		EWAD550TZPL2	EWAD550TZPR2	13
EWAD620TZPS2		EWAD620TZPL2	EWAD620TZPR2	13
EWAD720TZPS2		EWAD720TZPL2	EWAD720TZPR2	15
EWAD820TZPS2		EWAD820TZPL2	EWAD820TZPR2	15
EWAD950TZPS2		EWAD950TZPL2	EWAD950TZPR2	21

Water heat exchanger - maximum/maximum water Δt

The minimum and maximum allowed Δt at full load conditions are respectively 4 °C and 8°C Contact factory in case lower or higher Δt are required.

Minimum glycol percentage for low air ambient temperature to prevent freezing of the hydraulic circuit

Ambient temperature [°C]	-3	-8	-15	-20
Ethylene glycol [%]	10%	20%	30%	40%
Ambient temperature [°C]	-3	-7	-12	-20
Propylene glycol [%]	10%	20%	30%	40%

In presence of glycol in the water system the performance will be affected. Refer to the selection software. All machine protection systems, such as antifreeze, and low-pressure protection will need to be adjusted in accordance to the type and percentage of the glycol.

Air heat exchanger - Altitude correction factors

Elevation above sea level [m]	0	300	600	900	1200	1500	1800
Barometric pressure [mbar]	1013	977	942	908	875	843	812
Cooling capacity correction factor	1	0,993	0,986	0,979	0,973	0,967	0,96
Power input correction factor	1	1,005	1,009	1,015	1,021	1,026	1,031

Maximum operating altitude is 1800 m above sea level.
Contact factory if the unit has to be installed 1000 m above the sea level.

Available fan static pressure correction factors (for Silver and Gold version only)

External Static Pressure [Pa]	0	10	20	30
Cooling capacity [kW] correction factor	1,00	0,998	0,995	0,99
Compressor power input [kW] correction factor	1,00	1,006	1,01	1,02
Reduction of maximum condenser inlet air temperature [°C]	1,00	-0,3	-0,5	-1

The above table is valid for SILVER and GOLD series with standard fans. Application with more than 30 Pa of external static pressure are not recommended. In case where external static pressure over 30 Pa is required, contact factory.

Operating limits for Storage Environmental conditions must be within the following limits:

- Minimum ambient temperature: -20°C
- Maximum ambient temperature: 57°C
- Maximum R.H.: 95% not condensing

Storage below the minimum temperature may cause damage to components. Storage above the maximum temperature causes opening of safety valves.

Storage in condensing atmosphere may damage electronic components.

Heat recovery Units may be optionally equipped with heat recovery system. This system is made by a water cooled heat exchanger located on the compressors discharge pipe and a dedicated management of condensing pressure.

To guarantee compressor operation within its envelope, units with heat recovery cannot operate with water temperature of the heat recovery water lower than 25°C.

It is a responsibility of plant designer and chiller installer to guarantee the respect of this value (e.g. using recirculating bypass valve).

Water treatment Before putting the unit into operation, clean the water circuit. Dirt, scales, corrosion debris and other material can accumulate inside the heat exchanger and reduce its heat exchanging capacity. Pressure drop can increase as well, thus reducing water flow. Proper water treatment therefore reduces the risk of corrosion, erosion, scaling, etc.. The most appropriate water treatment must be determined locally, according to the type of system and water characteristics. The manufacturer is not responsible for damage to or malfunctioning of equipment caused by failure to treat water or by improperly treated water.

Water charge, flow and quality

Items (1) (6)	Cooling System				Cooling Water		Cooled Water		Heated water (2)		Tendency if out of criteria
	Circulating water		Once Flow		Circulating water [Below 20°C]	Supply water (4)	Low temperature		High temperature		
	Circulating water	Supply water (4)	Flowing water	Supply water (4)			Circulating water [20°C - 60°C]	Supply water (4)	Circulating water [60°C - 80°C]	Supply water (4)	
pH	6.5 - 8.2	6.0 - 8.0	5.0 - 8.0	5.0 - 8.0	6.8 - 8.0	5.0 - 8.0	7.0 - 8.0	7.0 - 8.0	7.0 - 8.0	7.0 - 8.0	Corrosion + Scale
Electrical conductivity	[mS/m] at 25°C	Below 80	Below 30	Below 40	Below 80	Below 80	Below 30	Below 30	Below 30	Below 30	Corrosion + Scale
	[µS/cm] at 25°C	(Below 800)	(Below 300)	(Below 400)	(Below 800)	(Below 800)	(Below 300)	(Below 300)	(Below 300)	(Below 300)	Corrosion + Scale
Chloride ion	[mgCl ⁻ /l]	Below 200	Below 50	Below 50	Below 200	Below 50	Below 50	Below 30	Below 30	Below 30	Corrosion
Sulfate ion	[mgSO ₄ ²⁻ /l]	Below 200	Below 50	Below 50	Below 200	Below 50	Below 50	Below 30	Below 30	Below 30	Corrosion
M-alkalinity (pH 8)	[mgCaCO ₃ /l]	Below 100	Below 50	Below 50	Below 100	Below 50	Below 50	Below 50	Below 50	Below 50	Scale
Total hardness	[mgCaCO ₃ /l]	Below 200	Below 70	Below 70	Below 200	Below 70	Below 70	Below 70	Below 70	Below 70	Scale
Calcium hardness	[mgCaCO ₃ /l]	Below 150	Below 50	Below 50	Below 50	Below 50	Below 50	Below 50	Below 50	Below 50	Scale
Silica ion	[mgSiO ₂ /l]	Below 50	Below 30	Below 30	Below 30	Below 30	Below 30	Below 30	Below 30	Below 30	Scale
Oxygen	(mg O ₂ /l)	Below 1.0	Below 1.0	Below 1.0	Below 1.0	Below 1.0	Below 1.0	Below 1.0	Below 1.0	Below 1.0	Corrosion
Particulate size	(mm)	Below 0.5	Below 0.5	Below 0.5	Below 0.5	Below 0.6	Below 0.5	Below 0.5	Below 0.5	Below 0.6	Erosion
Total dissolved solids	(mg / l)	Below 1000	Below 1000	Below 1000	Below 1000	Below 1001	Below 1000	Below 1000	Below 1000	Below 1001	Erosion
Ethylene Glycol (weight conc.)		Below 60%	Below 60%	---	Below 60%	Below 60%	Below 60%	Below 60%	Below 60%	Below 60%	---
Nitrate ion	(mg NO ₃ ⁻ /l)	Below 100	Below 100	Below 100	Below 100	Below 101	Below 100	Below 100	Below 100	Below 101	Corrosion
TOC Total organic carbon	(mg/l)	Below 1.0	Below 1.0	Below 1.0	Below 1.0	Below 1.0	Below 1.0	Below 1.0	Below 1.0	Below 1.0	Scale
Iron	[mgFe/l]	Below 1.0	Below 0.3	Below 1.0	Below 1.0	Below 0.3	Below 1.0	Below 1.0	Below 1.0	Below 0.3	Corrosion + Scale
Copper	[mgCu/l]	Below 0.3	Below 0.1	Below 1.0	Below 1.0	Below 1.0	Below 1.0	Below 1.0	Below 1.0	Below 0.1	Corrosion
Sulfite ion	[mgS ²⁻ /l]	Not detectable	Not detectable	Not detectable	Not detectable	Not detectable	Not detectable	Not detectable	Not detectable	Not detectable	Corrosion
Ammonium ion	[mgNH ₄ ⁺ /l]	Below 1.0	Below 0.1	Below 1.0	Below 1.0	Below 0.1	Below 0.3	Below 0.1	Below 0.1	Below 0.1	Corrosion
Remaining chloride	[mgCl ⁻ /l]	Below 0.3	Below 0.3	Below 0.3	Below 0.3	Below 0.3	Below 0.25	Below 0.3	Below 0.1	Below 0.3	Corrosion
Free carbide	[mgCO ₂ /l]	Below 4.0	Below 4.0	Below 4.0	Below 4.0	Below 4.0	Below 0.4	Below 4.0	Below 0.4	Below 4.0	Corrosion
Stability index		6.0 - 7.0	---	---	---	---	---	---	---	---	Corrosion + Scale

1 Names, definitions and units are according to SIS K 0101. Units and figures between brackets are old units published as reference only.

2 In case of using heated water (more than 40°C), corrosion is generally noticeable.

Especially when the iron materials in direct contact with water without any protection shields, it is desirable to give the valid measure for corrosion. E.g. chemical measure

3 In the cooling water using hermetic cooling tower, close circuit water is according to heated water standard, and scattered water is according to cooling water standard.

4 Supply water is considered drink water, industrial water and ground water except for genuine water, neutral water and soft water.

5 The above mentioned items are representable items in corrosion and scale cases.

6 The limits above have to be considered as a general prescription and can not totally assure the absence of corrosion and erosion.

Some particular combinations of elements or the presence of components not listed in the table or factors not considered may trigger corrosion phenomena.

Single pump low lift

EWAD TZ B SS/SL/SR (SILVER series) – Available static pressure - single pump low lift

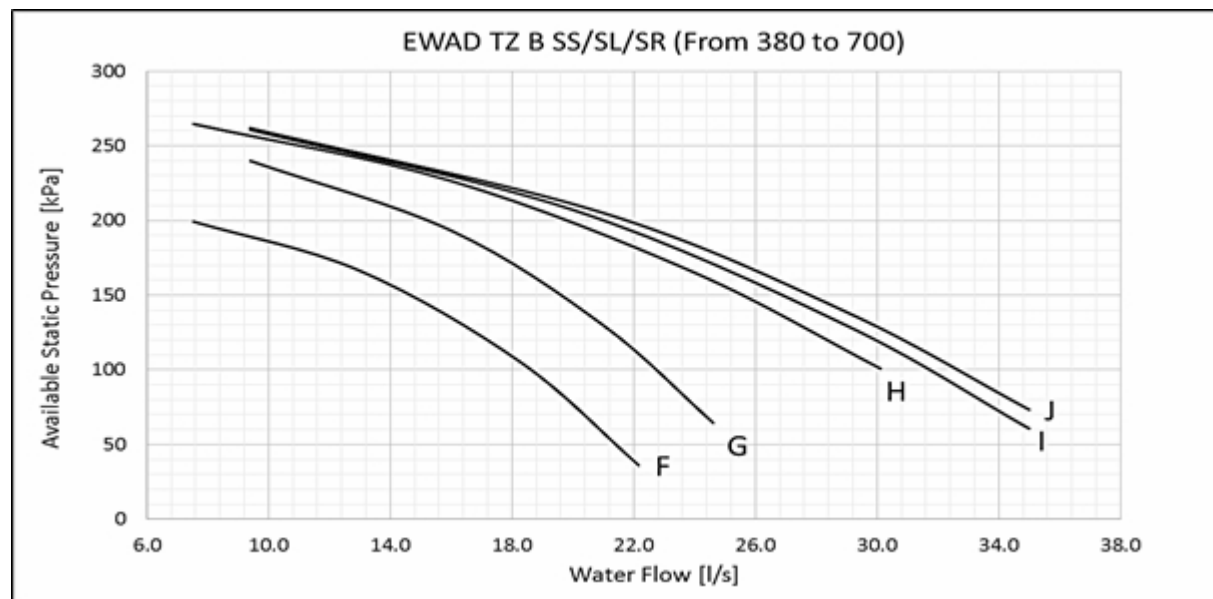
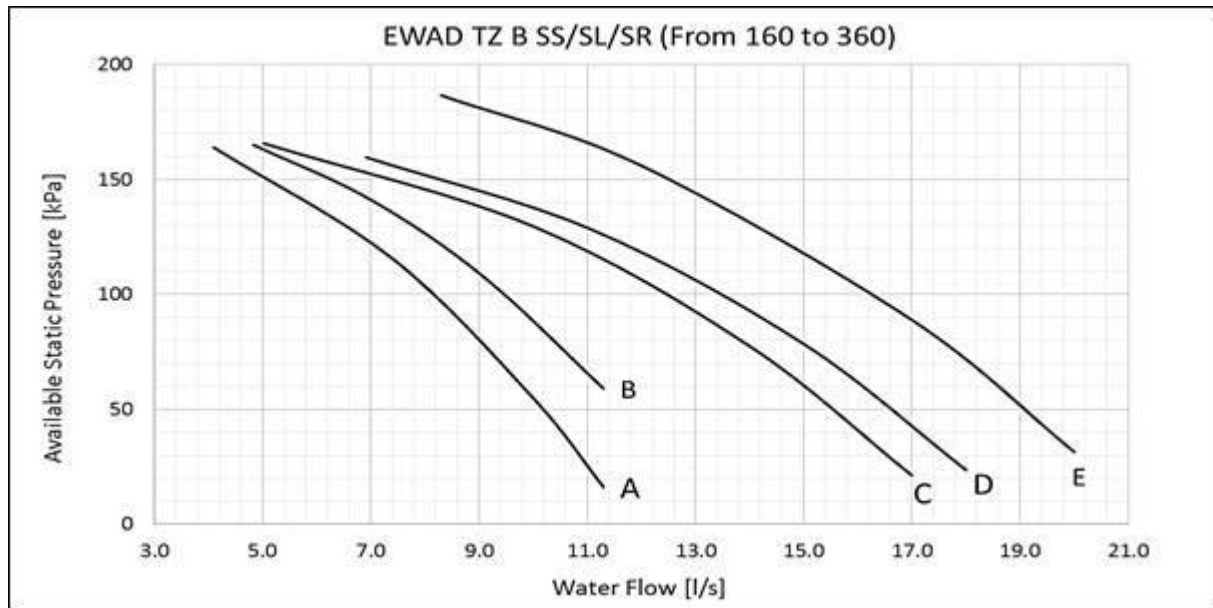

Technical data

	Model			Pump motor power [kW]	Pump motor current [A]	Power Supply	PN	Motor Protection	Insulation Class	Working temperature* [°C]	Max Ambient temperature [°C]	Ref. Curve
Single circuit	EWAD160TZ.S3B1	EWAD160TZSLB1	EWAD160TZSRB1	2.2	4.6	400V-3ph-50Hz	16	IP55	F	-25/120	40	A
	EWAD190TZ.S3B1	EWAD190TZSLB1	EWAD190TZSRB1	2.2	4.6	400V-3ph-50Hz	16	IP55	F	-25/120	40	B
	EWAD240TZ.S3B1	EWAD240TZSLB1	EWAD240TZSRB1	3	6.3	400V-3ph-50Hz	16	IP55	F	-25/120	40	D
	EWAD270TZ.S3B1	EWAD270TZSLB1	EWAD270TZSRB1	3	6.3	400V-3ph-50Hz	16	IP55	F	-25/120	40	C
	EWAD300TZ.S3B1	EWAD300TZSLB1	EWAD300TZSRB1	4	7.6	400V-3ph-50Hz	16	IP55	F	-25/120	40	E
Dual circuit	EWAD360TZ.S3B1	EWAD360TZSLB1	EWAD360TZSRB1	4	7.6	400V-3ph-50Hz	16	IP55	F	-25/120	40	E
	EWAD380TZ.S3B2	EWAD380TZSLB2	EWAD380TZSRB2	4	7.6	400V-3ph-50Hz	16	IP55	F	-25/120	40	F
	EWAD450TZ.S3B2	EWAD450TZSLB2	EWAD450TZSRB2	5.5	10.5	400V-3ph-50Hz	16	IP55	F	-25/120	40	G
	EWAD495TZ.S3B2	EWAD495TZSLB2	EWAD495TZSRB2	5.5	10.5	400V-3ph-50Hz	16	IP55	F	-25/120	40	G
	EWAD570TZ.S3B2	EWAD570TZSLB2	EWAD570TZSRB2	7.5	14.1	400V-3ph-50Hz	16	IP55	F	-25/120	40	H
	EWAD610TZ.S3B2	EWAD610TZSLB2	EWAD610TZSRB2	7.5	14.1	400V-3ph-50Hz	16	IP55	F	-25/120	40	J
	EWAD660TZ.S3B2	EWAD660TZSLB2	EWAD660TZSRB2	7.5	14.1	400V-3ph-50Hz	16	IP55	F	-25/120	40	I
	EWAD700TZ.S3B2	EWAD700TZSLB2	EWAD700TZSRB2	7.5	14.1	400V-3ph-50Hz	16	IP55	F	-25/120	40	I

Note: to calculate the total electrical data of the base unit selected with hydronic kit, the electrical data of the pump must be added to the electrical data of the base unit. Electrical data are subject to modification without notice. Please refer to unit nameplate.

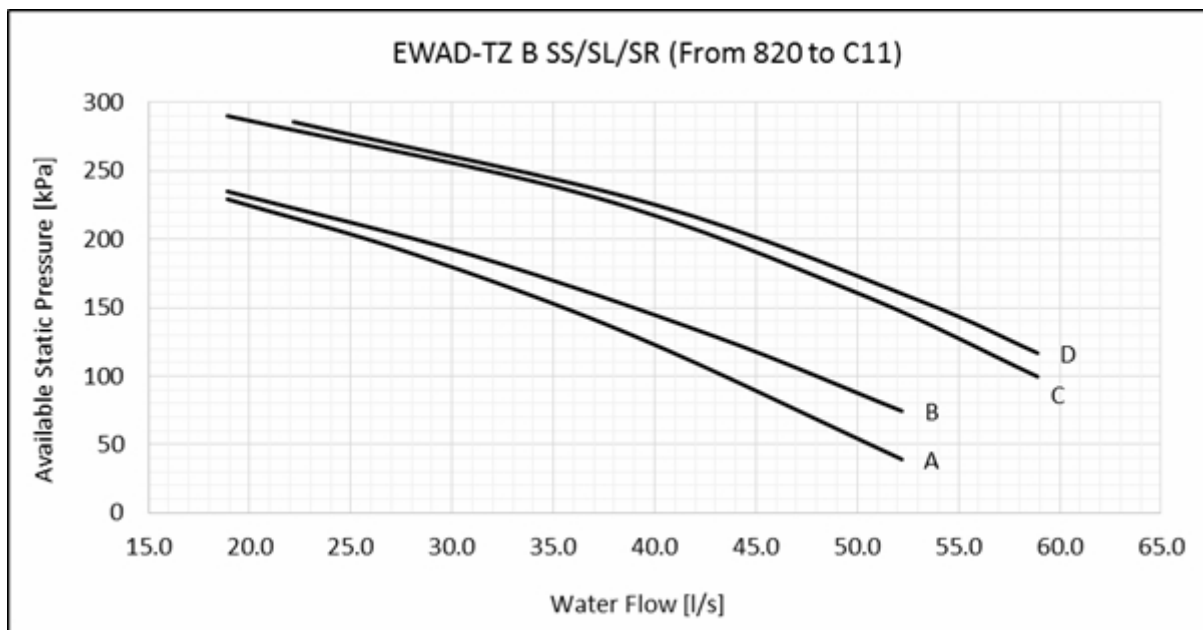

Technical data

Model			Pump motor power [kW]	Pump motor current [A]	Power Supply	PN	Motor Protection	Insulation Class	Working Temp.* [°C]	Max Amb Temp. [°C]	Ref. Curve
EWAD820TZSSB2	EWAD820TZSLB2	EWAD820TZSRB2	11	20.2	400V-3ph-50Hz	16	IP55	F	-25/120	40	A
EWAD900TZSSB2	EWAD900TZSLB2	EWAD900TZSRB2	11	20.2	400V-3ph-50Hz	16	IP55	F	-25/120	40	B
EWAD990TZSSB2	EWAD990TZSLB2	EWAD990TZSRB2	15	26.6	400V-3ph-50Hz	16	IP55	F	-25/120	40	C
EWADC10TZSSB2	EWADC10TZSLB2	EWADC10TZSRB2	15	26.6	400V-3ph-50Hz	16	IP55	F	-25/120	40	C
EWADC11TZSSB2	EWADC11TZSLB2	EWADC11TZSRB2	15	26.6	400V-3ph-50Hz	16	IP55	F	-25/120	40	D

Note: to calculate the total electrical data of the base unit selected with hydronic kit, the electrical data of the pump must be added to the electrical data of the base unit. Electrical data are subject to modification without notice. Please refer to unit nameplate.

EWAD TZ B XS/XL/XR (GOLD series) – Available static pressure - single pump low lift

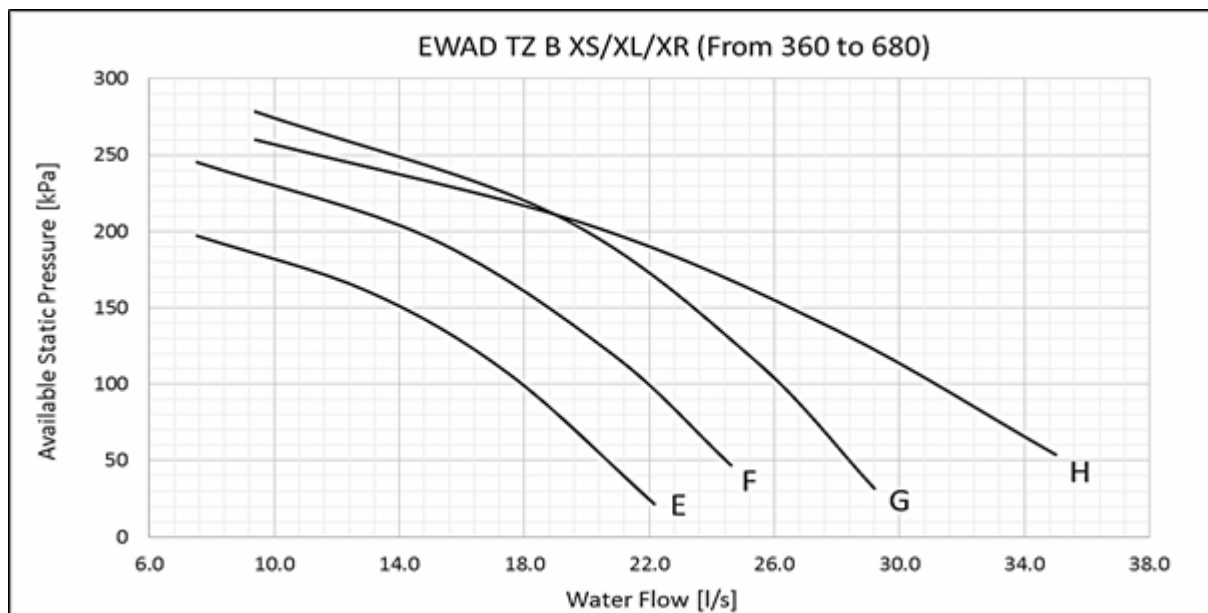
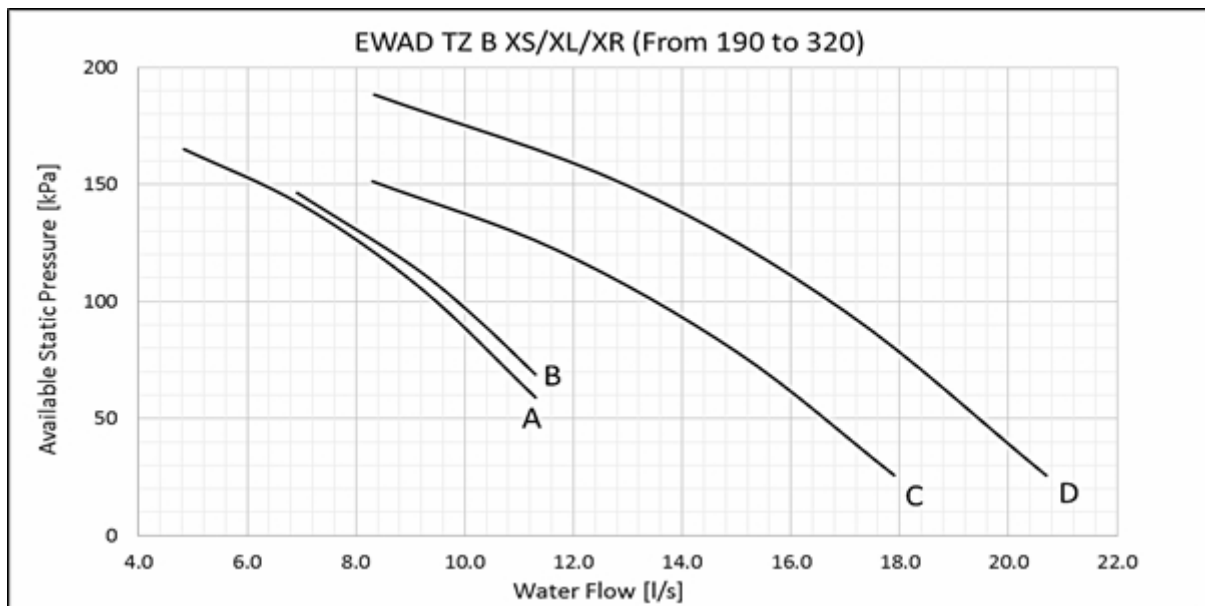

Technical data

	Model			Pump motor power [kW]	Pump motor current [A]	Power Supply	PN	Motor Protection	Insulation Class	Working temperature * [°C]	Max Ambient temperature [°C]	Ref. Curve
Single circuit	E WAD 190T ZXSB1	EWAD 190TZ XLB1	E WAD 190T ZXRb1	2.2	4.6	400V-3ph-50Hz	16	IP55	F	-25/120	40	A
	E WAD 220T ZXSB1	EWAD 220TZ XLB1	E WAD 220T ZXRb1	2.2	4.6	400V-3ph-50Hz	16	IP55	F	-25/120	40	B
	E WAD 240T ZXSB1	EWAD 240TZ XLB1	E WAD 240T ZXRb1	3	6.3	400V-3ph-50Hz	16	IP55	F	-25/120	40	C
	E WAD 290T ZXSB1	EWAD 290TZ XLB1	E WAD 290T ZXRb1	3	6.3	400V-3ph-50Hz	16	IP55	F	-25/120	40	C
	E WAD 320T ZXSB1	EWAD 320TZ XLB1	E WAD 320T ZXRb1	4	7.6	400V-3ph-50Hz	16	IP55	F	-25/120	40	D
Dual circuit	E WAD 360T ZXSB2	EWAD 360TZ XLB2	E WAD 360T ZXRb2	4	7.6	400V-3ph-50Hz	16	IP55	F	-25/120	40	E
	E WAD 420T ZXSB2	EWAD 420TZ XLB2	E WAD 420T ZXRb2	4	7.6	400V-3ph-50Hz	16	IP55	F	-25/120	40	E
	E WAD 450T ZXSB2	EWAD 450TZ XLB2	E WAD 450T ZXRb2	5.5	10.5	400V-3ph-50Hz	16	IP55	F	-25/120	40	F
	E WAD 540T ZXSB2	EWAD 540TZ XLB2	E WAD 540T ZXRb2	7.5	14.1	400V-3ph-50Hz	16	IP55	F	-25/120	40	G
	E WAD 570T ZXSB2	EWAD 570TZ XLB2	E WAD 570T ZXRb2	7.5	14.1	400V-3ph-50Hz	16	IP55	F	-25/120	40	G
	E WAD 610T ZXSB2	EWAD 610TZ XLB2	E WAD 610T ZXRb2	7.5	14.1	400V-3ph-50Hz	16	IP55	F	-25/120	40	H
	E WAD 660T ZXSB2	EWAD 660TZ XLB2	E WAD 660T ZXRb2	7.5	14.1	400V-3ph-50Hz	16	IP55	F	-25/120	40	H
	E WAD 680T ZXSB2	EWAD 680TZ XLB2	E WAD 680T ZXRb2	7.5	14.1	400V-3ph-50Hz	16	IP55	F	-25/120	40	H

Note: to calculate the total electrical data of the base unit selected with hydronic kit, the electrical data of the pump must be added to the electrical data of the base unit. Electrical data are subject to modification without notice. Please refer to unit nameplate.

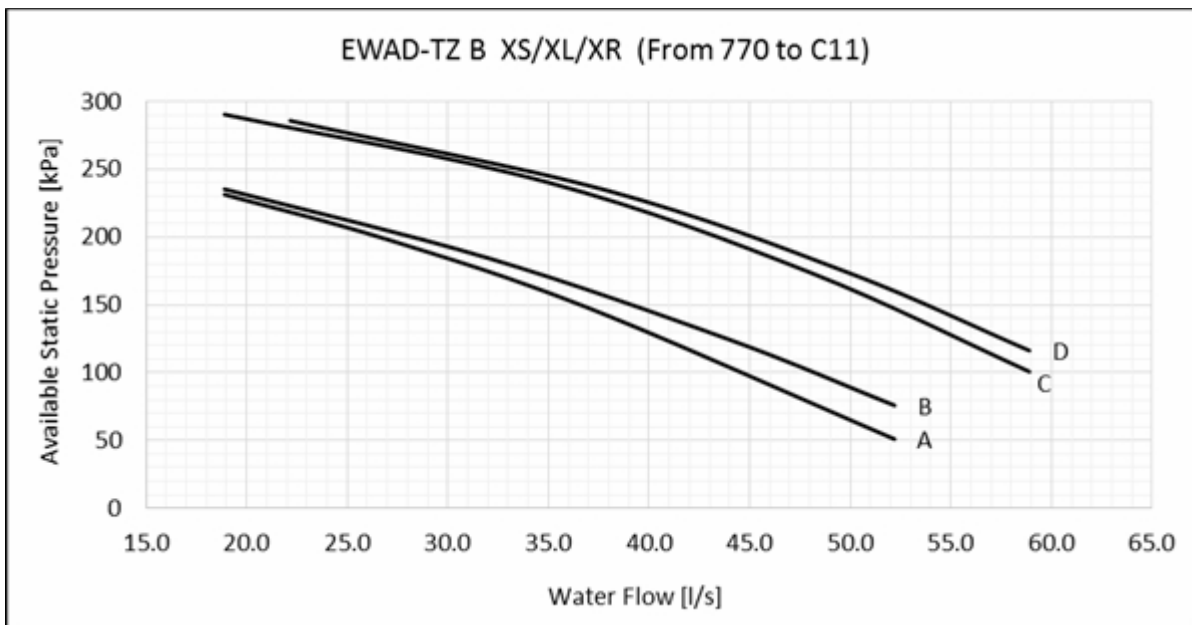

Technical data

Model			Pump motor power [kW]	Pump motor current [A]	Power Supply	PN	Motor Protection	Insulation Class	Working Temp.* [°C]	Max Amb Temp. [°C]	Ref. Curve
EWAD770TZXS2	EWAD770TZXL2	EWAD770TZXR2	11	20.2	400V-3ph-50Hz	16	IP55	F	-25/120	40	A
EWAD850TZXS2	EWAD850TZXL2	EWAD850TZXR2	11	20.2	400V-3ph-50Hz	16	IP55	F	-25/120	40	B
EWAD910TZXS2	EWAD910TZXL2	EWAD910TZXR2	11	20.2	400V-3ph-50Hz	16	IP55	F	-25/120	40	B
EWADC10TZXS2	EWADC10TZXL2	EWADC10TZXR2	15	26.6	400V-3ph-50Hz	16	IP55	F	-25/120	40	C
EWADC11TZXS2	EWADC11TZXL2	EWADC11TZXR2	15	26.6	400V-3ph-50Hz	16	IP55	F	-25/120	40	D

Note: to calculate the total electrical data of the base unit selected with hydronic kit, the electrical data of the pump must be added to the electrical data of the base unit. Electrical data are subject to modification without notice. Please refer to unit nameplate.

EWAD TZ B PS/PL/PR (PLATINUM series) – Available static pressure - single pump low lift

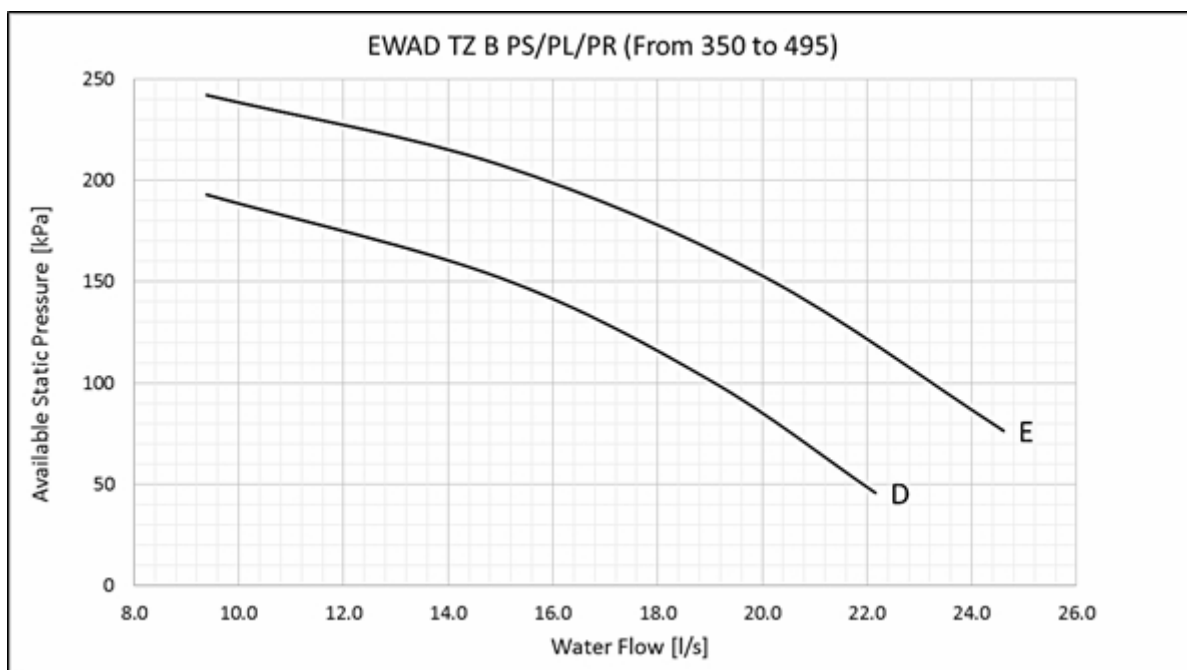
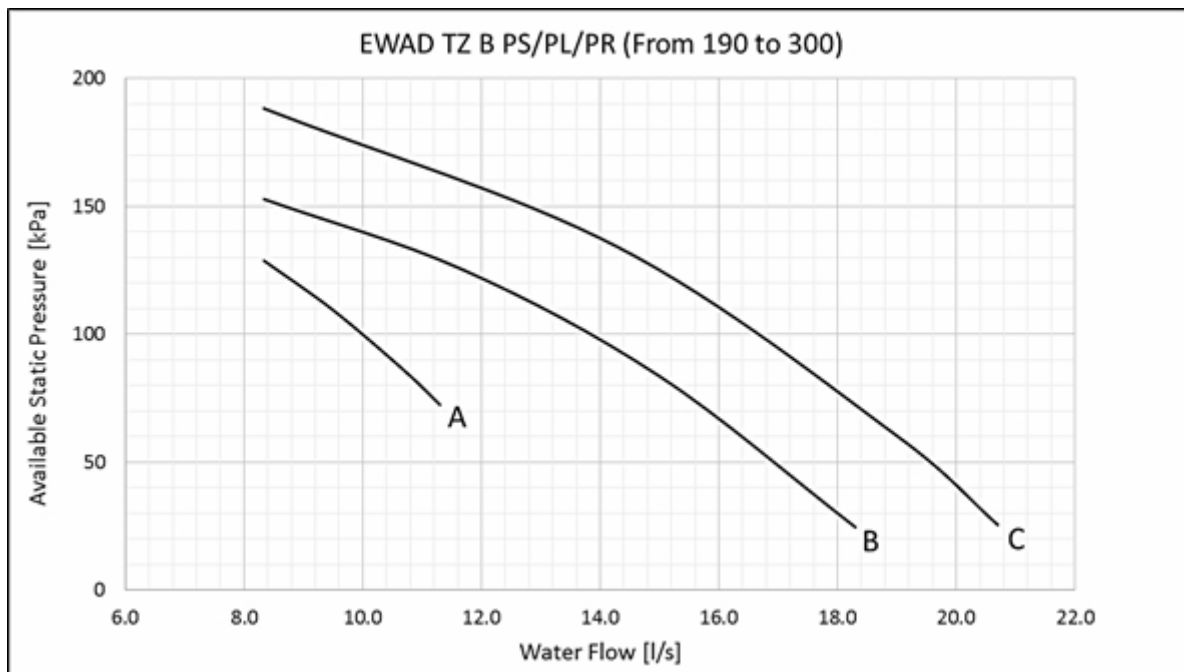

Technical data

	Model			Pump motor power [kW]	Pump motor current [A]	Power Supply	PN	Motor Protection	Insulation Class	Working temperature* [°C]	Max Ambient temperature [°C]	Ref. Curve
Single circuit	EWAD190TZP5B1	EWAD190TZPLB1	EWAD190TZPRB1	2.2	4.6	400V-3ph-50Hz	16	IP55	F	-25/120	40	A
	EWAD220TZP5B1	EWAD220TZPLB1	EWAD220TZPRB1	2.2	4.6	400V-3ph-50Hz	16	IP55	F	-25/120	40	A
	EWAD240TZP5B1	EWAD240TZPLB1	EWAD240TZPRB1	3	6.3	400V-3ph-50Hz	16	IP55	F	-25/120	40	B
	EWAD290TZP5B1	EWAD290TZPLB1	EWAD290TZPRB1	3	6.3	400V-3ph-50Hz	16	IP55	F	-25/120	40	B
	EWAD300TZP5B1	EWAD300TZPLB1	EWAD300TZPRB1	4	7.6	400V-3ph-50Hz	16	IP55	F	-25/120	40	C
Dual circuit	EWAD350TZP5B2	EWAD350TZPLB2	EWAD350TZPRB2	4	7.6	400V-3ph-50Hz	16	IP55	F	-25/120	40	D
	EWAD420TZP5B2	EWAD420TZPLB2	EWAD420TZPRB2	4	7.6	400V-3ph-50Hz	16	IP55	F	-25/120	40	D
	EWAD495TZP5B2	EWAD495TZPLB2	EWAD495TZPRB2	5.5	10.5	400V-3ph-50Hz	16	IP55	F	-25/120	40	E

Note: to calculate the total electrical data of the base unit selected with hydronic kit, the electrical data of the pump must be added to the electrical data of the base unit. Electrical data are subject to modification without notice. Please refer to unit nameplate.

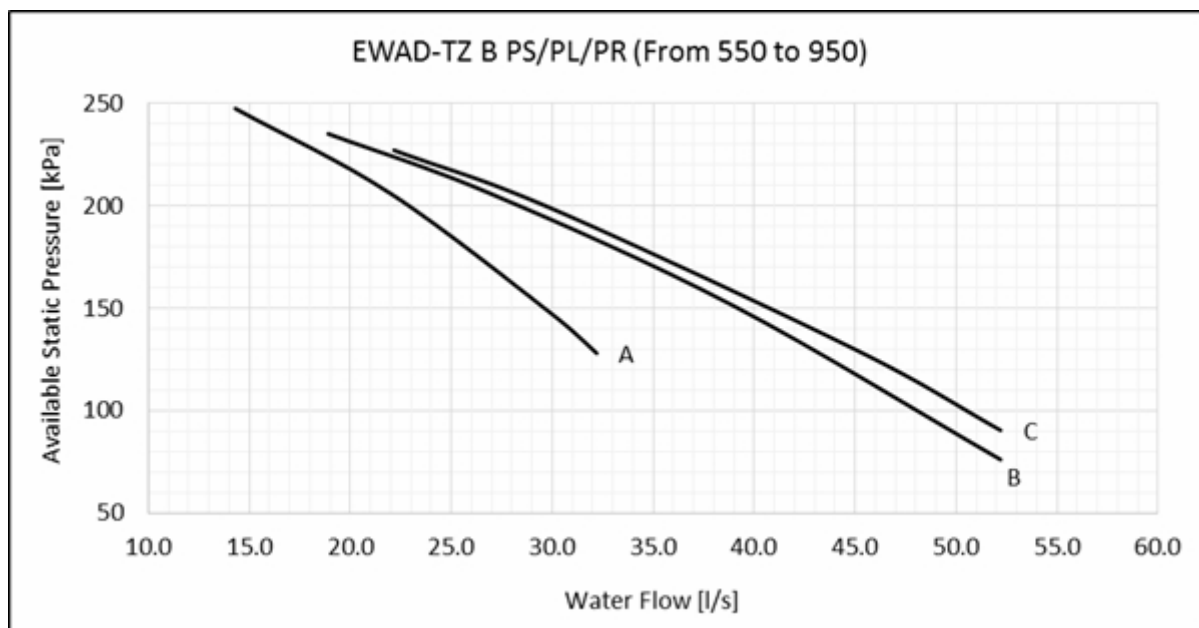

Technical data

Model			Pump motor power [kW]	Pump motor current [A]	Power Supply	PN	Motor Protection	Insulation Class	Working Temp.* [°C]	Max Amb Temp. [°C]	Ref. Curve
EWAD550TZPSB2	EWAD550TZPLB2	EWAD550TZPRB2	7.5	14.1	400V-3ph-50Hz	16	IP55	F	-25/120	40	A
EWAD620TZPSB2	EWAD620TZPLB2	EWAD620TZPRB2	7.5	14.1	400V-3ph-50Hz	16	IP55	F	-25/120	40	A
EWAD720TZPSB2	EWAD720TZPLB2	EWAD720TZPRB2	11	20.2	400V-3ph-50Hz	16	IP55	F	-25/120	40	B
EWAD820TZPSB2	EWAD820TZPLB2	EWAD820TZPRB2	11	20.2	400V-3ph-50Hz	16	IP55	F	-25/120	40	B
EWAD950TZPSB2	EWAD950TZPLB2	EWAD950TZPRB2	11	20.2	400V-3ph-50Hz	16	IP55	F	-25/120	40	C

Note: to calculate the total electrical data of the base unit selected with hydronic kit, the electrical data of the pump must be added to the electrical data of the base unit. Electrical data are subject to modification without notice. Please refer to unit nameplate.

Single pump high lift

EWAD TZ B SS/SL/SR (SILVER series) – Available static pressure - single pump high lift

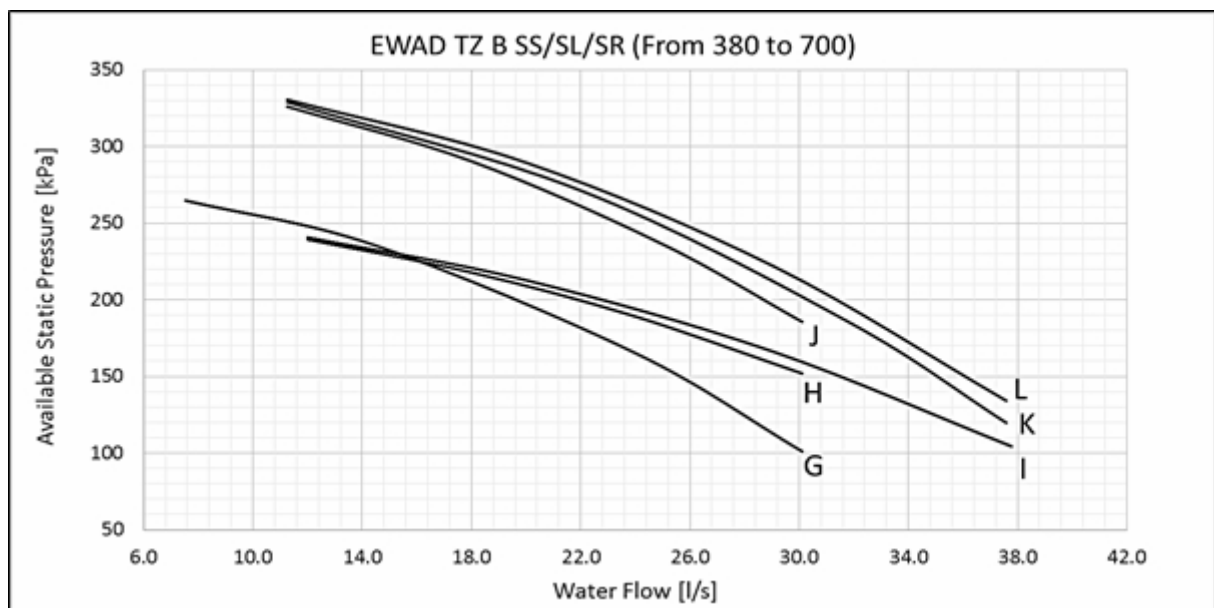
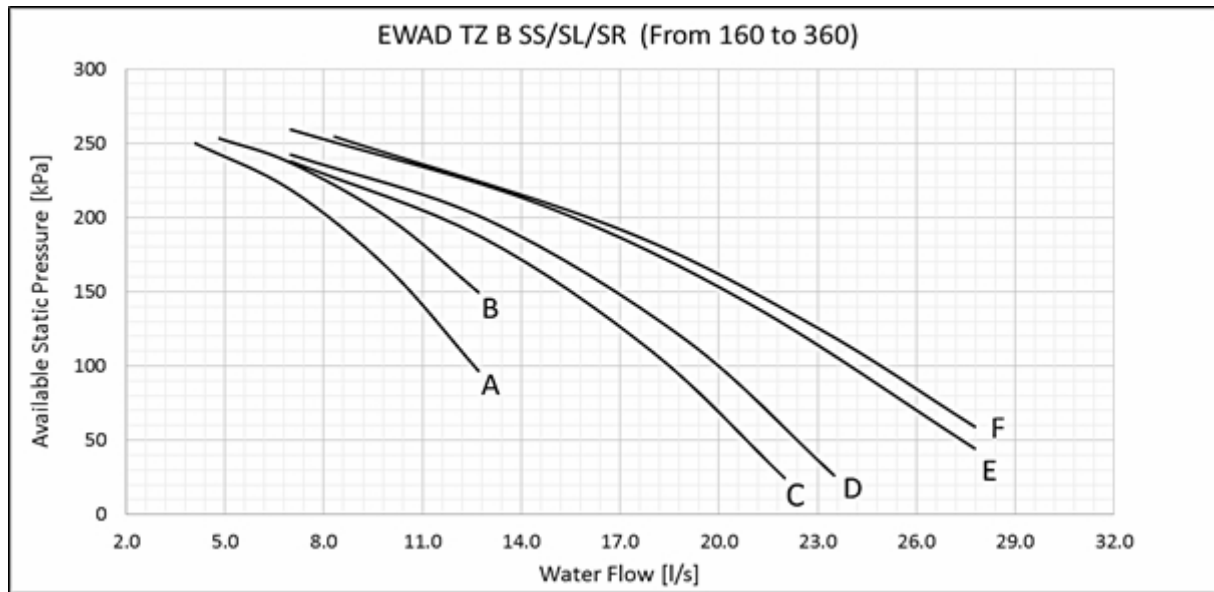

Technical data

	Model			Pump motor power [kW]	Pump motor current [A]	Power Supply	PN	Motor Protection	Insulation Class	Working temperature* [°C]	Max Ambient temperature [°C]	Ref. Curve
Single circuit	EWAD160TZ.S3B1	EWAD160TZSLB1	EWAD160TZSRB1	4	7.6	400V-3ph-50Hz	16	IP55	F	-25/120	40	A
	EWAD190TZ.S3B1	EWAD190TZSLB1	EWAD190TZSRB1	4	7.6	400V-3ph-50Hz	16	IP55	F	-25/120	40	B
	EWAD240TZ.S3B1	EWAD240TZSLB1	EWAD240TZSRB1	5.5	10.5	400V-3ph-50Hz	16	IP55	F	-25/120	40	D
	EWAD270TZ.S3B1	EWAD270TZSLB1	EWAD270TZSRB1	5.5	10.5	400V-3ph-50Hz	16	IP55	F	-25/120	40	C
	EWAD300TZ.S3B1	EWAD300TZSLB1	EWAD300TZSRB1	7.5	14.1	400V-3ph-50Hz	16	IP55	F	-25/120	40	E
	EWAD360TZ.S3B1	EWAD360TZSLB1	EWAD360TZSRB1	7.5	14.1	400V-3ph-50Hz	16	IP55	F	-25/120	40	F
Dual circuit	EWAD380TZ.S3B2	EWAD380TZSLB2	EWAD380TZSRB2	7.5	14.1	400V-3ph-50Hz	16	IP55	F	-25/120	40	G
	EWAD450TZ.S3B2	EWAD450TZSLB2	EWAD450TZSRB2	11	20.2	400V-3ph-50Hz	16	IP55	F	-25/120	40	I
	EWAD495TZ.S3B2	EWAD495TZSLB2	EWAD495TZSRB2	11	20.2	400V-3ph-50Hz	16	IP55	F	-25/120	40	H
	EWAD570TZ.S3B2	EWAD570TZSLB2	EWAD570TZSRB2	11	20.2	400V-3ph-50Hz	16	IP55	F	-25/120	40	J
	EWAD610TZ.S3B2	EWAD610TZSLB2	EWAD610TZSRB2	11	20.2	400V-3ph-50Hz	16	IP55	F	-25/120	40	L
	EWAD660TZ.S3B2	EWAD660TZSLB2	EWAD660TZSRB2	11	20.2	400V-3ph-50Hz	16	IP55	F	-25/120	40	K
	EWAD700TZ.S3B2	EWAD700TZSLB2	EWAD700TZSRB2	11	20.2	400V-3ph-50Hz	16	IP55	F	-25/120	40	K

Note: to calculate the total electrical data of the base unit selected with hydronic kit, the electrical data of the pump must be added to the electrical data of the base unit. Electrical data are subject to modification without notice. Please refer to unit nameplate.

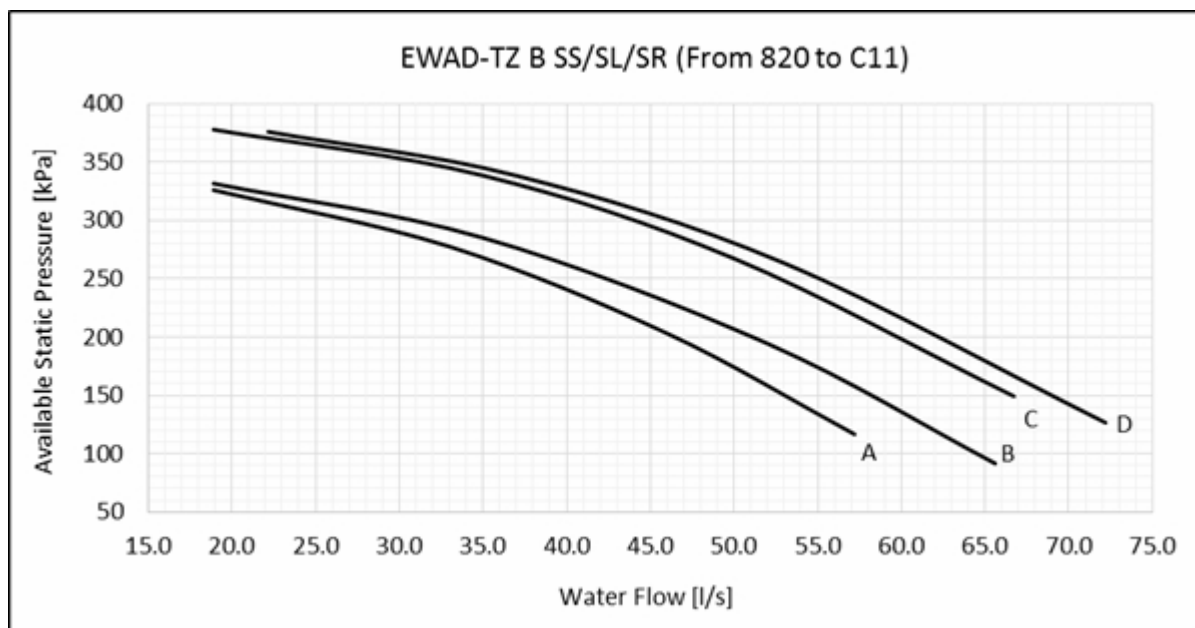

Technical data

Model			Pump motor power [kW]	Pump motor current [A]	Power Supply	PN	Motor Protection	Insulation Class	Working Temp.* [°C]	Max Amb Temp. [°C]	Ref. Curve
EWAD820TZSSB2	EWAD820TZSLB2	EWAD820TZSRB2	18.5	32.7	400V-3ph-50Hz	16	IP55	F	-25/120	40	A
EWAD900TZSSB2	EWAD900TZSLB2	EWAD900TZSRB2	18.5	32.7	400V-3ph-50Hz	16	IP55	F	-25/120	40	B
EWAD990TZSSB2	EWAD990TZSLB2	EWAD990TZSRB2	22	42.2	400V-3ph-50Hz	16	IP55	F	-25/120	40	C
EWADC10TZSSB2	EWADC10TZSLB2	EWADC10TZSRB2	22	42.2	400V-3ph-50Hz	16	IP55	F	-25/120	40	C
EWADC11TZSSB2	EWADC11TZSLB2	EWADC11TZSRB2	22	42.2	400V-3ph-50Hz	16	IP55	F	-25/120	40	D

Note: to calculate the total electrical data of the base unit selected with hydronic kit, the electrical data of the pump must be added to the electrical data of the base unit. Electrical data are subject to modification without notice. Please refer to unit nameplate.

EWAD TZ B XS/XL/XR (GOLD series) – Available static pressure - single pump high lift

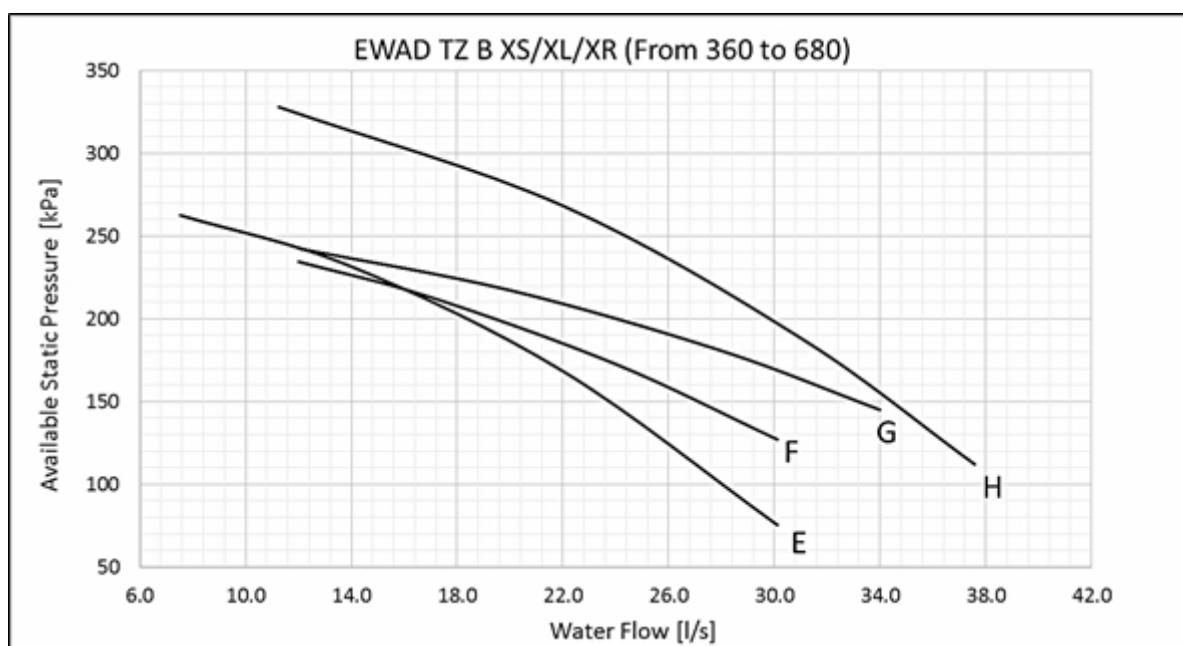
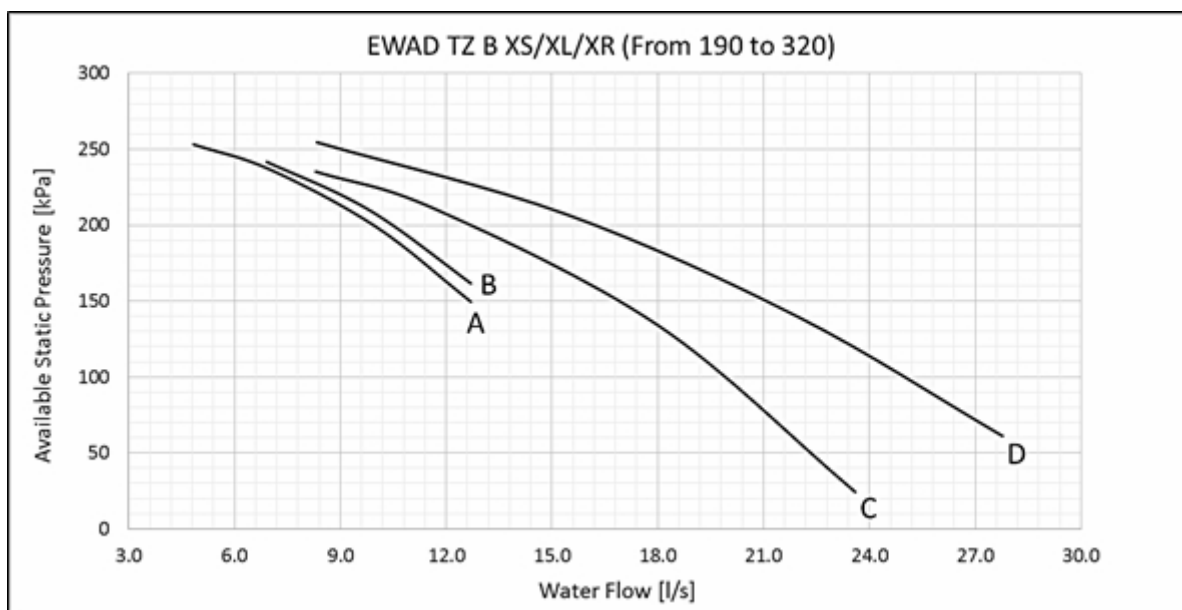

Technical data

	Model			Pump motor power [kW]	Pump motor current [A]	Power Supply	PN	Motor Protection	Insulation Class	Working temperature * [°C]	Max Ambient temperature [°C]	Ref. Curve
Single circuit	EWAD 190TZ XS B1	EWAD 190TZ XL B1	EWAD 190TZ XR B1	4	7.6	400V-3ph-50Hz	16	IP55	F	-25/120	40	A
	EWAD 220TZ XS B1	EWAD 220TZ XL B1	EWAD 220TZ XR B1	4	7.6	400V-3ph-50Hz	16	IP55	F	-25/120	40	B
	EWAD 240TZ XS B1	EWAD 240TZ XL B1	EWAD 240TZ XR B1	5.5	10.5	400V-3ph-50Hz	16	IP55	F	-25/120	40	C
	EWAD 290TZ XS B1	EWAD 290TZ XL B1	EWAD 290TZ XR B1	5.5	10.5	400V-3ph-50Hz	16	IP55	F	-25/120	40	C
	EWAD 320TZ XS B1	EWAD 320TZ XL B1	EWAD 320TZ XR B1	7.5	14.1	400V-3ph-50Hz	16	IP55	F	-25/120	40	D
Dual circuit	EWAD 360TZ XS B2	EWAD 360TZ XL B2	EWAD 360TZ XR B2	7.5	14.1	400V-3ph-50Hz	16	IP55	F	-25/120	40	E
	EWAD 420TZ XS B2	EWAD 420TZ XL B2	EWAD 420TZ XR B2	7.5	14.1	400V-3ph-50Hz	16	IP55	F	-25/120	40	E
	EWAD 450TZ XS B2	EWAD 450TZ XL B2	EWAD 450TZ XR B2	11	20.2	400V-3ph-50Hz	16	IP55	F	-25/120	40	F
	EWAD 540TZ XS B2	EWAD 540TZ XL B2	EWAD 540TZ XR B2	11	20.2	400V-3ph-50Hz	16	IP55	F	-25/120	40	G
	EWAD 570TZ XS B2	EWAD 570TZ XL B2	EWAD 570TZ XR B2	11	20.2	400V-3ph-50Hz	16	IP55	F	-25/120	40	G
	EWAD 610TZ XS B2	EWAD 610TZ XL B2	EWAD 610TZ XR B2	11	20.2	400V-3ph-50Hz	16	IP55	F	-25/120	40	H
	EWAD 660TZ XS B2	EWAD 660TZ XL B2	EWAD 660TZ XR B2	11	20.2	400V-3ph-50Hz	16	IP55	F	-25/120	40	H
	EWAD 680TZ XS B2	EWAD 680TZ XL B2	EWAD 680TZ XR B2	11	20.2	400V-3ph-50Hz	16	IP55	F	-25/120	40	H

Note: to calculate the total electrical data of the base unit selected with hydronic kit, the electrical data of the pump must be added to the electrical data of the base unit. Electrical data are subject to modification without notice. Please refer to unit nameplate.

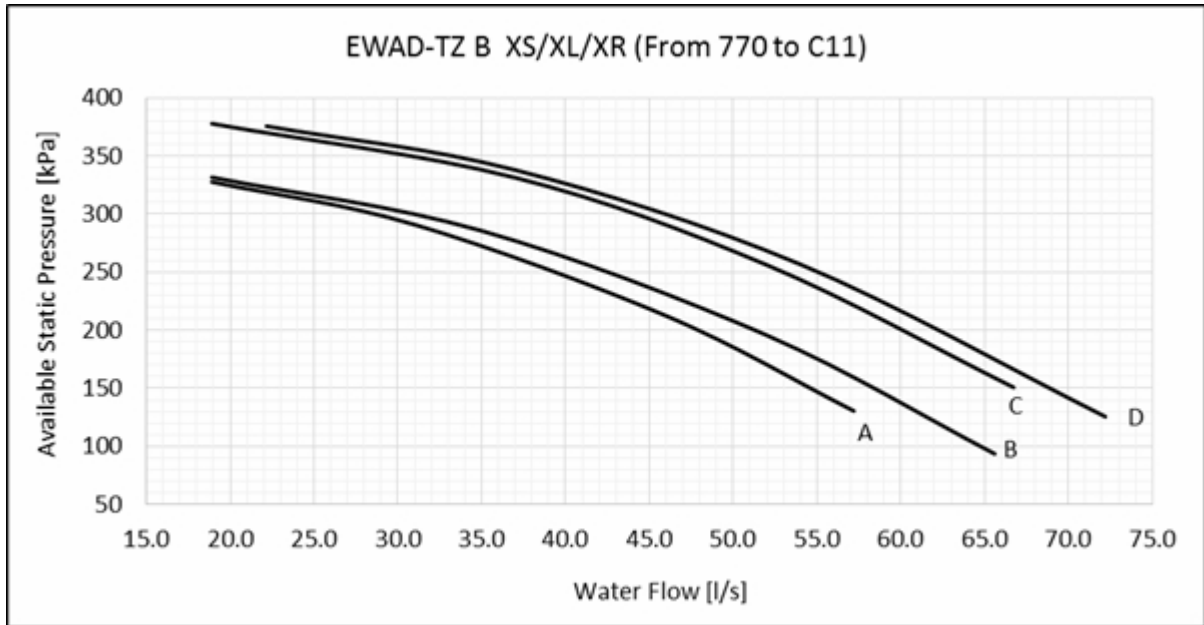

Technical data

Model			Pump motor power [kW]	Pump motor current [A]	Power Supply	PN	Motor Protection	Insulation Class	Working Temp.* [°C]	Max Amb Temp. [°C]	Ref. Curve
EWAD770TZXS2	EWAD770TZXL2	EWAD770TZXR2	18.5	32.7	400V-3ph-50Hz	16	IP55	F	-25/120	40	A
EWAD850TZXS2	EWAD850TZXL2	EWAD850TZXR2	18.5	32.7	400V-3ph-50Hz	16	IP55	F	-25/120	40	B
EWAD910TZXS2	EWAD910TZXL2	EWAD910TZXR2	18.5	32.7	400V-3ph-50Hz	16	IP55	F	-25/120	40	B
EWADC10TZXS2	EWADC10TZXL2	EWADC10TZXR2	22	42.2	400V-3ph-50Hz	16	IP55	F	-25/120	40	C
EWADC11TZXS2	EWADC11TZXL2	EWADC11TZXR2	22	42.2	400V-3ph-50Hz	16	IP55	F	-25/120	40	D

Note: to calculate the total electrical data of the base unit selected with hydronic kit, the electrical data of the pump must be added to the electrical data of the base unit. Electrical data are subject to modification without notice. Please refer to unit nameplate.

EWAD TZ B PS/PL/PR (PLATINUM series) - Available static pressure - single pump high lift

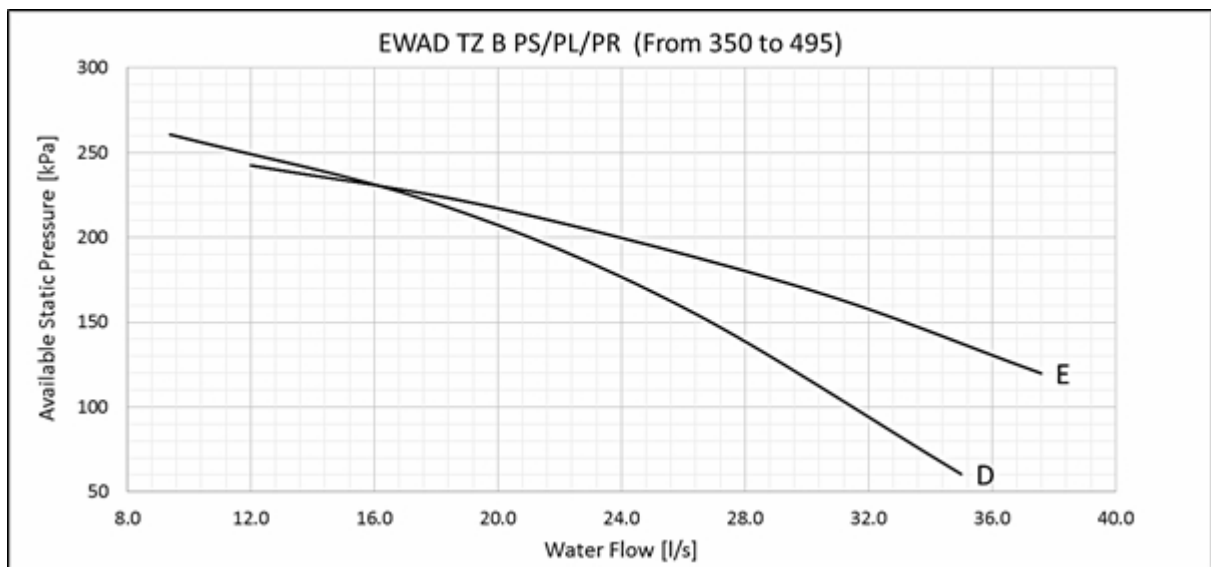
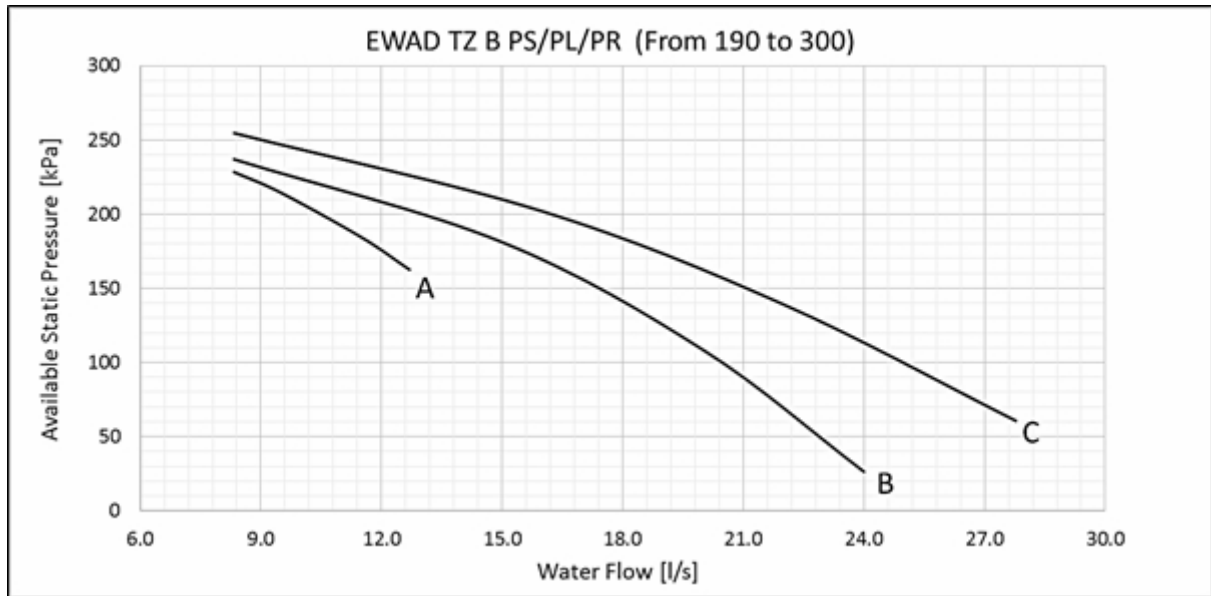

Technical data

	Model			Pump motor power [kW]	Pump motor current [A]	Power Supply	PN	Motor Protection	Insulation Class	Working temperature* [°C]	Max Ambient temperature [°C]	Ref. Curve
Single circuit	EWAD190TZPSB1	EWAD190TZPLB1	EWAD190TZPRB1	4	7.6	400V-3ph-50Hz	16	IP55	F	-25/120	40	A
	EWAD220TZPSB1	EWAD220TZPLB1	EWAD220TZPRB1	4	7.6	400V-3ph-50Hz	16	IP55	F	-25/120	40	A
	EWAD240TZPSB1	EWAD240TZPLB1	EWAD240TZPRB1	5.5	10.5	400V-3ph-50Hz	16	IP55	F	-25/120	40	B
	EWAD290TZPSB1	EWAD290TZPLB1	EWAD290TZPRB1	5.5	10.5	400V-3ph-50Hz	16	IP55	F	-25/120	40	B
	EWAD300TZPSB1	EWAD300TZPLB1	EWAD300TZPRB1	7.5	14.1	400V-3ph-50Hz	16	IP55	F	-25/120	40	C
Dual circuit	EWAD350TZPSB2	EWAD350TZPLB2	EWAD350TZPRB2	7.5	14.1	400V-3ph-50Hz	16	IP55	F	-25/120	40	D
	EWAD420TZPSB2	EWAD420TZPLB2	EWAD420TZPRB2	7.5	14.1	400V-3ph-50Hz	16	IP55	F	-25/120	40	D
	EWAD495TZPSB2	EWAD495TZPLB2	EWAD495TZPRB2	11	20.2	400V-3ph-50Hz	16	IP55	F	-25/120	40	E

Note: to calculate the total electrical data of the base unit selected with hydronic kit, the electrical data of the pump must be added to the electrical data of the base unit. Electrical data are subject to modification without notice. Please refer to unit nameplate.

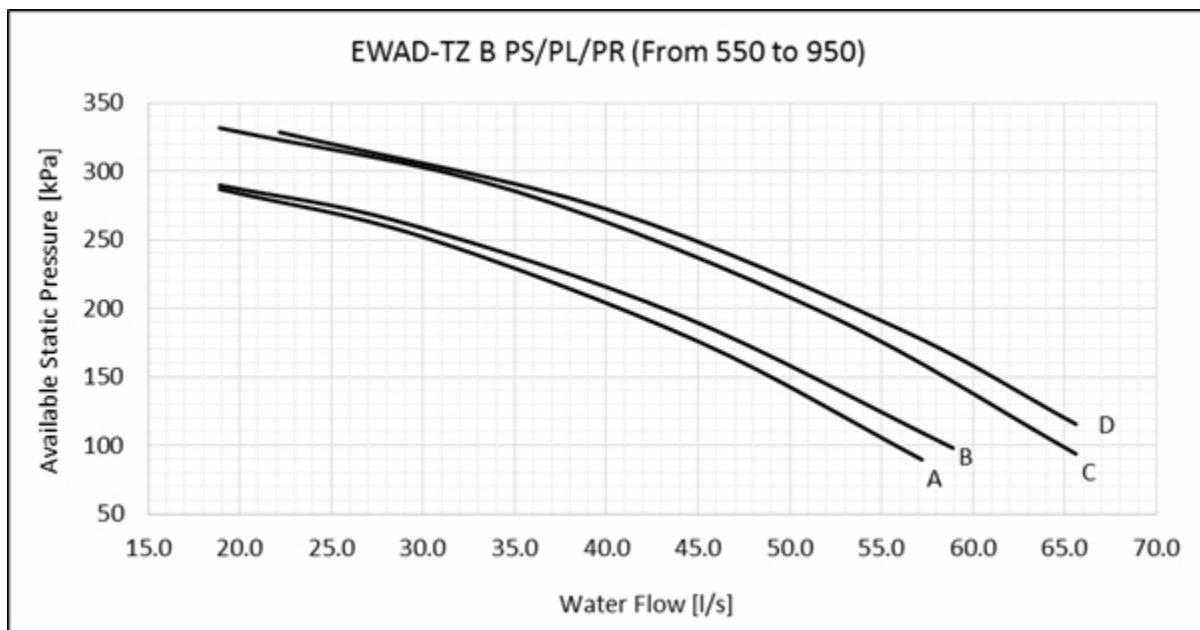

Technical data

Model			Pump motor power [kW]	Pump motor current [A]	Power Supply	PN	Motor Protection	Insulation Class	Working Temp.* [°C]	Max Amb Temp. [°C]	Ref. Curve
EWAD550TZPSB2	EWAD550TZPLB2	EWAD550TZPRB2	15	26.6	400V-3ph-50Hz	16	IP55	F	-25/120	40	A
EWAD620TZPSB2	EWAD620TZPLB2	EWAD620TZPRB2	15	26.6	400V-3ph-50Hz	16	IP55	F	-25/120	40	A
EWAD720TZPSB2	EWAD720TZPLB2	EWAD720TZPRB2	15	26.6	400V-3ph-50Hz	16	IP55	F	-25/120	40	B
EWAD820TZPSB2	EWAD820TZPLB2	EWAD820TZPRB2	18.5	32.7	400V-3ph-50Hz	16	IP55	F	-25/120	40	C
EWAD950TZPSB2	EWAD950TZPLB2	EWAD950TZPRB2	18.5	32.7	400V-3ph-50Hz	16	IP55	F	-25/120	40	D

Note: to calculate the total electrical data of the base unit selected with hydronic kit, the electrical data of the pump must be added to the electrical data of the base unit. Electrical data are subject to modification without notice. Please refer to unit nameplate.

Double pump low lift

EWAD TZ B SS/SL/SR (SILVER series) – Available static pressure - double pump low lift

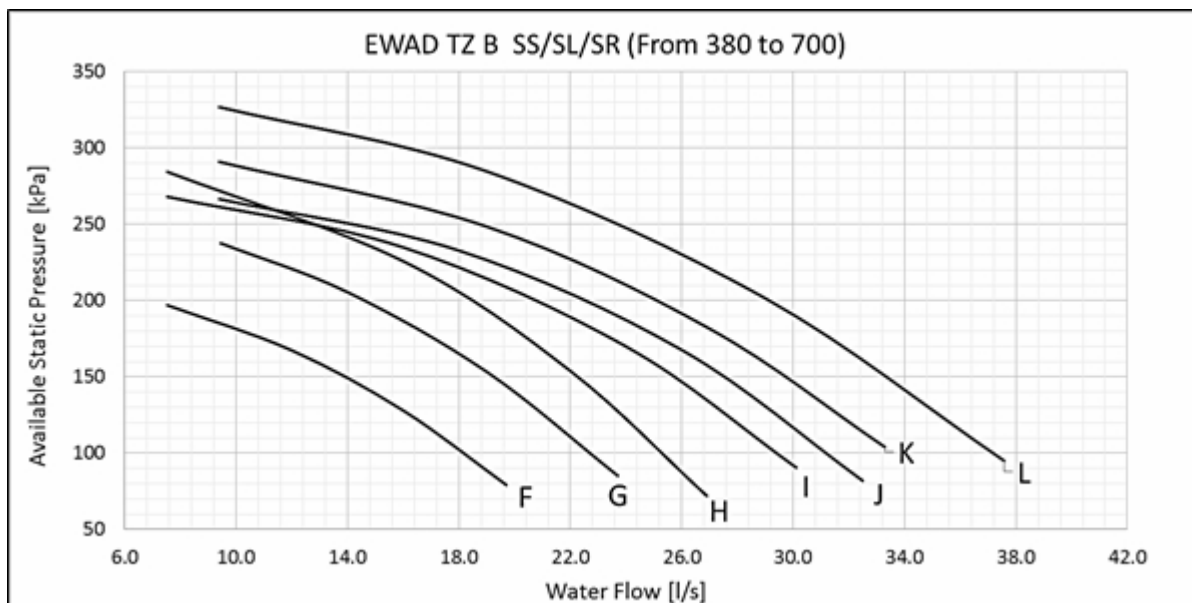
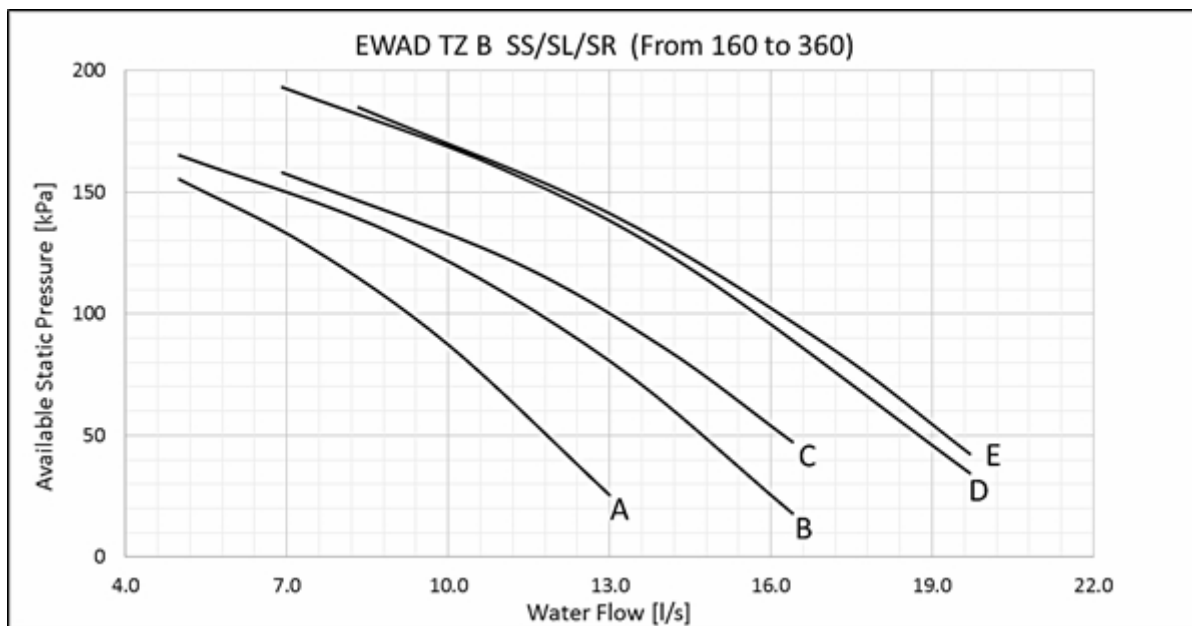

Technical data

	Model			Pump motor power [kW]	Pump motor current [A]	Power Supply	PN	Motor Protection	Insulation Class	Working temperature* [°C]	Max Ambient temperature [°C]	Ref. Curve
Single circuit	EWAD160TZ.S3B.1	EWAD160TZ.SL.B.1	EWAD160TZ.SR.B.1	3	6.3	400V-3ph-50Hz	16	IP55	F	-25/120	40	A
	EWAD190TZ.S3B.1	EWAD190TZ.SL.B.1	EWAD190TZ.SR.B.1	3	6.3	400V-3ph-50Hz	16	IP55	F	-25/120	40	B
	EWAD240TZ.S3B.1	EWAD240TZ.SL.B.1	EWAD240TZ.SR.B.1	3	6.3	400V-3ph-50Hz	16	IP55	F	-25/120	40	C
	EWAD270TZ.S3B.1	EWAD270TZ.SL.B.1	EWAD270TZ.SR.B.1	3	6.3	400V-3ph-50Hz	16	IP55	F	-25/120	40	B
	EWAD300TZ.S3B.1	EWAD300TZ.SL.B.1	EWAD300TZ.SR.B.1	4	7.6	400V-3ph-50Hz	16	IP55	F	-25/120	40	D
Dual circuit	EWAD360TZ.S3B.1	EWAD360TZ.SL.B.1	EWAD360TZ.SR.B.1	4	7.6	400V-3ph-50Hz	16	IP55	F	-25/120	40	E
	EWAD380TZ.S3B.2	EWAD380TZ.SL.B.2	EWAD380TZ.SR.B.2	4	7.6	400V-3ph-50Hz	16	IP55	F	-25/120	40	F
	EWAD450TZ.S3B.2	EWAD450TZ.SL.B.2	EWAD450TZ.SR.B.2	5.5	10.5	400V-3ph-50Hz	16	IP55	F	-25/120	40	G
	EWAD495TZ.S3B.2	EWAD495TZ.SL.B.2	EWAD495TZ.SR.B.2	7.5	14.1	400V-3ph-50Hz	16	IP55	F	-25/120	40	H
	EWAD570TZ.S3B.2	EWAD570TZ.SL.B.2	EWAD570TZ.SR.B.2	7.5	14.1	400V-3ph-50Hz	16	IP55	F	-25/120	40	I
	EWAD610TZ.S3B.2	EWAD610TZ.SL.B.2	EWAD610TZ.SR.B.2	7.5	14.1	400V-3ph-50Hz	16	IP55	F	-25/120	40	J
	EWAD660TZ.S3B.2	EWAD660TZ.SL.B.2	EWAD660TZ.SR.B.2	9.2	17.2	400V-3ph-50Hz	16	IP55	F	-25/120	40	K
EWAD700TZ.S3B.2	EWAD700TZ.SL.B.2	EWAD700TZ.SR.B.2	11	20.2	400V-3ph-50Hz	16	IP55	F	-25/120	40	L	

Note: to calculate the total electrical data of the base unit selected with hydronic kit, the electrical data of the pump must be added to the electrical data of the base unit. Electrical data are subject to modification without notice. Please refer to unit nameplate.

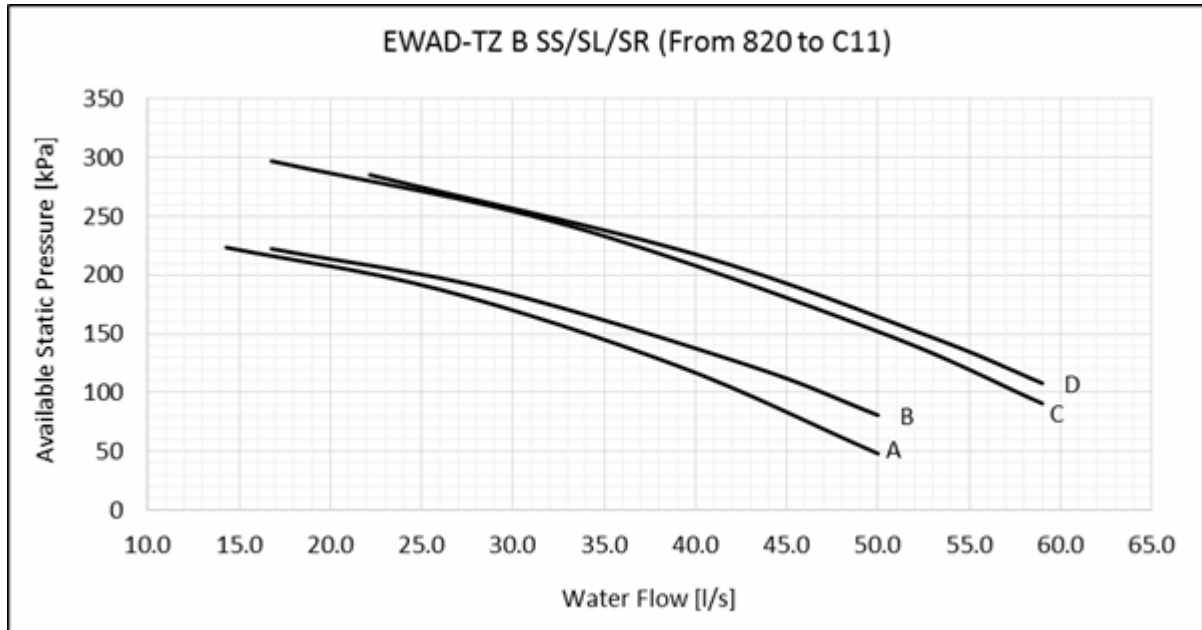

Technical data

Model			Pump motor power [kW]	Pump motor current [A]	Power Supply	PN	Motor Protection	Insulation Class	Working Temp.* [°C]	Max Amb Temp. [°C]	Ref. Curve
EWAD820TZSSB2	EWAD820TZSLB2	EWAD820TZSRB2	11	20.2	400V-3ph-50Hz	16	IP55	F	-25/120	40	A
EWAD900TZSSB2	EWAD900TZSLB2	EWAD900TZSRB2	11	20.2	400V-3ph-50Hz	16	IP55	F	-25/120	40	B
EWAD990TZSSB2	EWAD990TZSLB2	EWAD990TZSRB2	15	26.6	400V-3ph-50Hz	16	IP55	F	-25/120	40	C
EWADC10TZSSB2	EWADC10TZSLB2	EWADC10TZSRB2	15	26.6	400V-3ph-50Hz	16	IP55	F	-25/120	40	C
EWADC11TZSSB2	EWADC11TZSLB2	EWADC11TZSRB2	15	26.6	400V-3ph-50Hz	16	IP55	F	-25/120	40	D

Note: to calculate the total electrical data of the base unit selected with hydronic kit, the electrical data of the pump must be added to the electrical data of the base unit. Electrical data are subject to modification without notice. Please refer to unit nameplate.

EWAD TZ B XS/XL/XR (GOLD series) – Available static pressure - double pump low lift

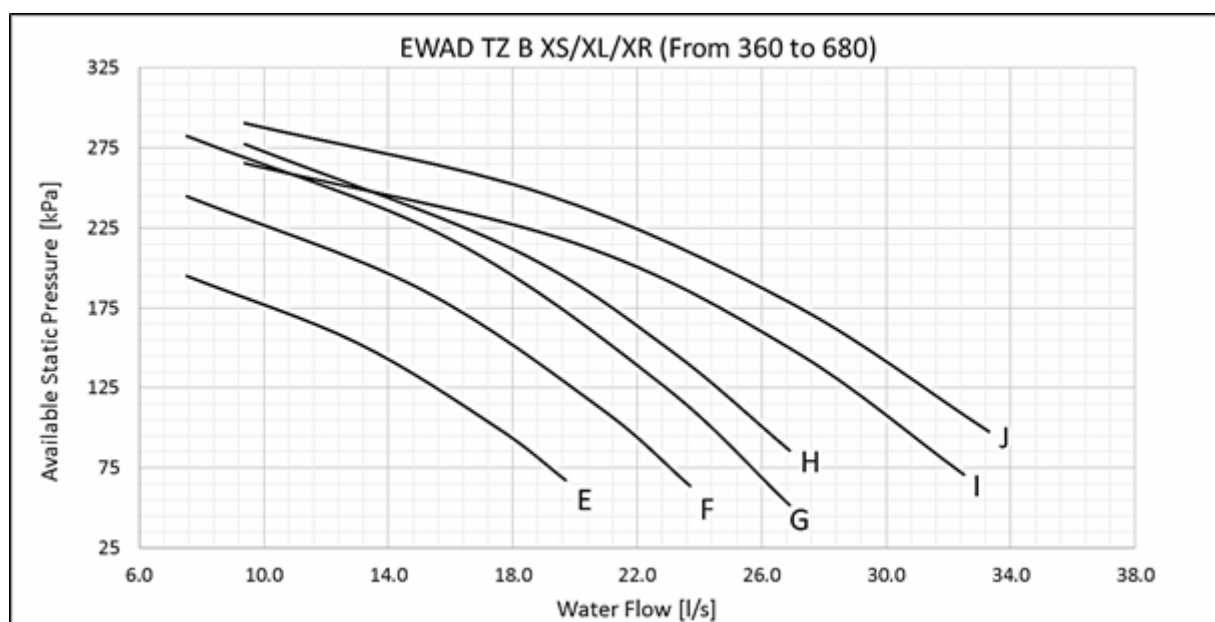
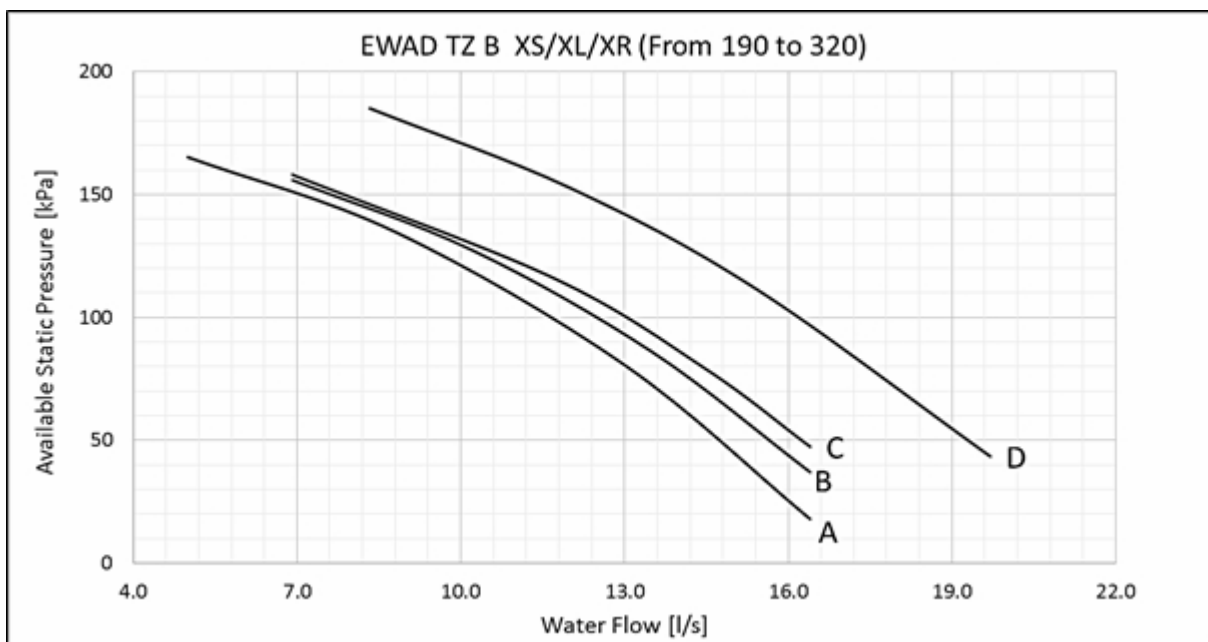

Technical data

	Model			Pump motor power [kW]	Pump motor current [A]	Power Supply	PN	Motor Protection	Insulation Class	Working temperature * [°C]	Max Ambient temperature [°C]	Ref. Curve
Single circuit	E WAD 19 0T ZX SB 1	EWAD 19 0TZ XLB 1	E WAD 19 0T ZX RB 1	3	6.3	400V-3ph-50Hz	16	IP55	F	-25/120	40	A
	E WAD 22 0T ZX SB 1	EWAD 22 0TZ XLB 1	E WAD 22 0T ZX RB 1	3	6.3	400V-3ph-50Hz	16	IP55	F	-25/120	40	B
	E WAD 24 0T ZX SB 1	EWAD 24 0TZ XLB 1	E WAD 24 0T ZX RB 1	3	6.3	400V-3ph-50Hz	16	IP55	F	-25/120	40	C
	E WAD 29 0T ZX SB 1	EWAD 29 0TZ XLB 1	E WAD 29 0T ZX RB 1	3	6.3	400V-3ph-50Hz	16	IP55	F	-25/120	40	C
	E WAD 32 0T ZX SB 1	EWAD 32 0TZ XLB 1	E WAD 32 0T ZX RB 1	4	7.6	400V-3ph-50Hz	16	IP55	F	-25/120	40	D
Dual circuit	E WAD 36 0T ZX SB 2	EWAD 36 0TZ XLB 2	E WAD 36 0T ZX RB 2	4	7.6	400V-3ph-50Hz	16	IP55	F	-25/120	40	E
	E WAD 42 0T ZX SB 2	EWAD 42 0TZ XLB 2	E WAD 42 0T ZX RB 2	5.5	10.5	400V-3ph-50Hz	16	IP55	F	-25/120	40	F
	E WAD 45 0T ZX SB 2	EWAD 45 0TZ XLB 2	E WAD 45 0T ZX RB 2	7.5	14.1	400V-3ph-50Hz	16	IP55	F	-25/120	40	G
	E WAD 54 0T ZX SB 2	EWAD 54 0TZ XLB 2	E WAD 54 0T ZX RB 2	7.5	14.1	400V-3ph-50Hz	16	IP55	F	-25/120	40	H
	E WAD 57 0T ZX SB 2	EWAD 57 0TZ XLB 2	E WAD 57 0T ZX RB 2	7.5	14.1	400V-3ph-50Hz	16	IP55	F	-25/120	40	I
	E WAD 61 0T ZX SB 2	EWAD 61 0TZ XLB 2	E WAD 61 0T ZX RB 2	7.5	14.1	400V-3ph-50Hz	16	IP55	F	-25/120	40	I
	E WAD 66 0T ZX SB 2	EWAD 66 0TZ XLB 2	E WAD 66 0T ZX RB 2	9.2	17.2	400V-3ph-50Hz	16	IP55	F	-25/120	40	J
	E WAD 68 0T ZX SB 2	EWAD 68 0TZ XLB 2	E WAD 68 0T ZX RB 2	9.2	17.2	400V-3ph-50Hz	16	IP55	F	-25/120	40	J

Note: to calculate the total electrical data of the base unit selected with hydronic kit, the electrical data of the pump must be added to the electrical data of the base unit. Electrical data are subject to modification without notice. Please refer to unit nameplate.

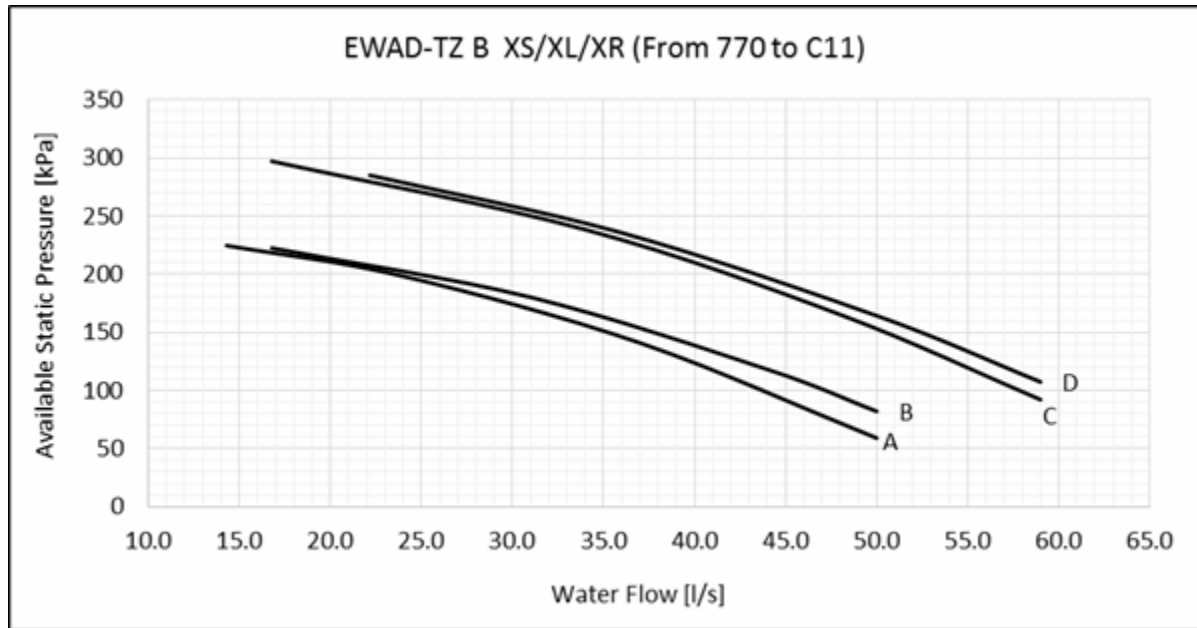

Technical data

Model			Pump motor power [kW]	Pump motor current [A]	Power Supply	PN	Motor Protection	Insulation Class	Working Temp.* [°C]	Max Amb Temp. [°C]	Ref. Curve
EWAD770TZXS2	EWAD770TZLB2	EWAD770TZRB2	11	20.2	400V-3ph-50Hz	16	IP55	F	-25/120	40	A
EWAD850TZXS2	EWAD850TZLB2	EWAD850TZRB2	11	20.2	400V-3ph-50Hz	16	IP55	F	-25/120	40	B
EWAD910TZXS2	EWAD910TZLB2	EWAD910TZRB2	11	20.2	400V-3ph-50Hz	16	IP55	F	-25/120	40	B
EWADC10TZXS2	EWADC10TZLB2	EWADC10TZRB2	15	26.6	400V-3ph-50Hz	16	IP55	F	-25/120	40	C
EWADC11TZXS2	EWADC11TZLB2	EWADC11TZRB2	15	26.6	400V-3ph-50Hz	16	IP55	F	-25/120	40	D

Note: to calculate the total electrical data of the base unit selected with hydronic kit, the electrical data of the pump must be added to the electrical data of the base unit. Electrical data are subject to modification without notice. Please refer to unit nameplate.

EWAD TZ B PS/PL/PR (PLATINUM series) – Available static pressure - double pump low lift

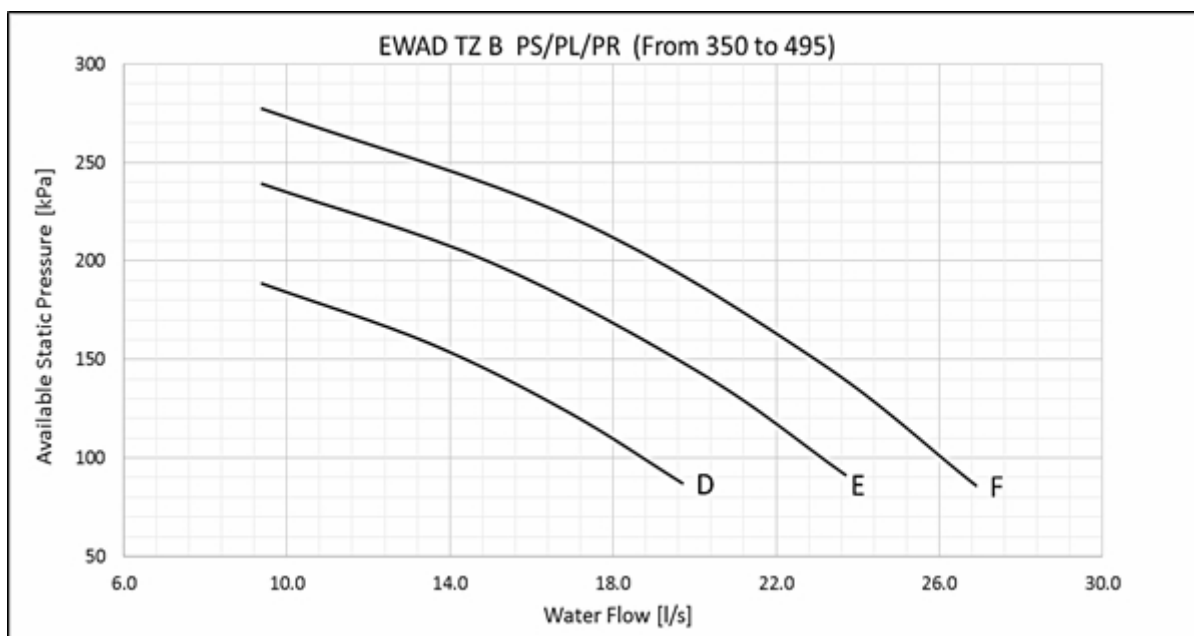
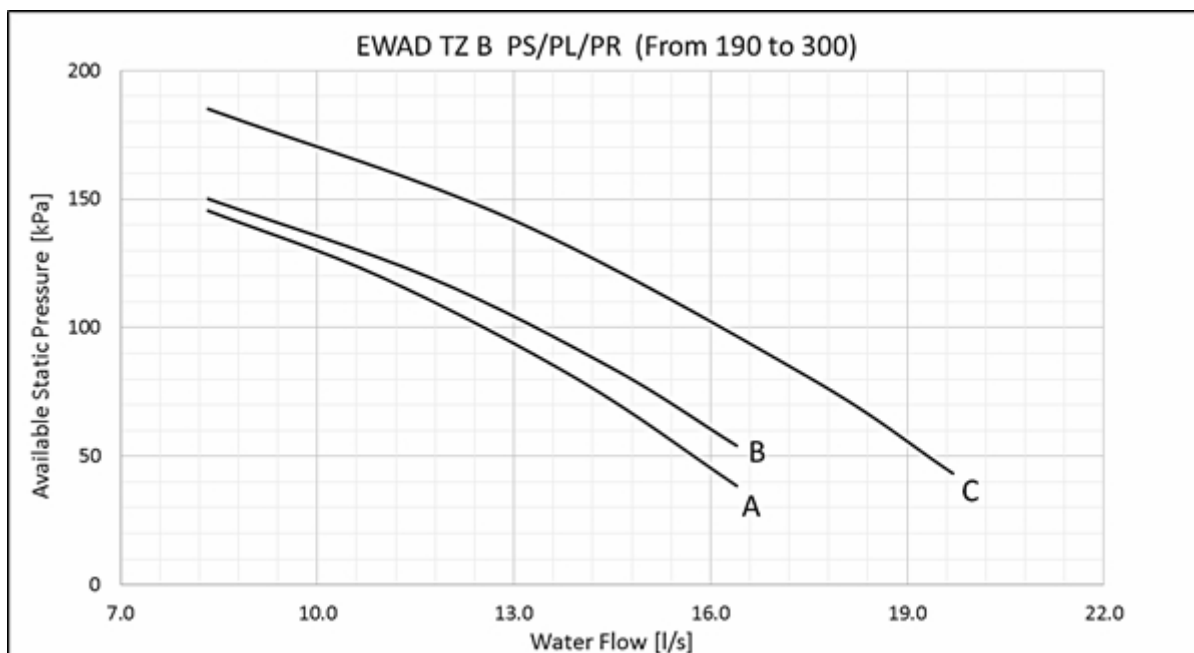

Technical data

	Model			Pump motor power [kW]	Pump motor current [A]	Power Supply	PN	Motor Protection	Insulation Class	Working temperature* [°C]	Max Ambient temperature [°C]	Ref. Curve
Single circuit	EWAD190TZPSB1	EWAD190TZPLB1	EWAD190TZPRB1	3	6.3	400V-3ph-50Hz	16	IP55	F	-25/120	40	A
	EWAD220TZPSB1	EWAD220TZPLB1	EWAD220TZPRB1	3	6.3	400V-3ph-50Hz	16	IP55	F	-25/120	40	A
	EWAD240TZPSB1	EWAD240TZPLB1	EWAD240TZPRB1	3	6.3	400V-3ph-50Hz	16	IP55	F	-25/120	40	B
	EWAD290TZPSB1	EWAD290TZPLB1	EWAD290TZPRB1	3	6.3	400V-3ph-50Hz	16	IP55	F	-25/120	40	B
	EWAD300TZPSB1	EWAD300TZPLB1	EWAD300TZPRB1	4	7.6	400V-3ph-50Hz	16	IP55	F	-25/120	40	C
Dual circuit	EWAD350TZPSB2	EWAD350TZPLB2	EWAD350TZPRB2	4	7.6	400V-3ph-50Hz	16	IP55	F	-25/120	40	D
	EWAD420TZPSB2	EWAD420TZPLB2	EWAD420TZPRB2	5.5	10.5	400V-3ph-50Hz	16	IP55	F	-25/120	40	E
	EWAD495TZPSB2	EWAD495TZPLB2	EWAD495TZPRB2	7.5	14.1	400V-3ph-50Hz	16	IP55	F	-25/120	40	F

Note: to calculate the total electrical data of the base unit selected with hydronic kit, the electrical data of the pump must be added to the electrical data of the base unit. Electrical data are subject to modification without notice. Please refer to unit nameplate.

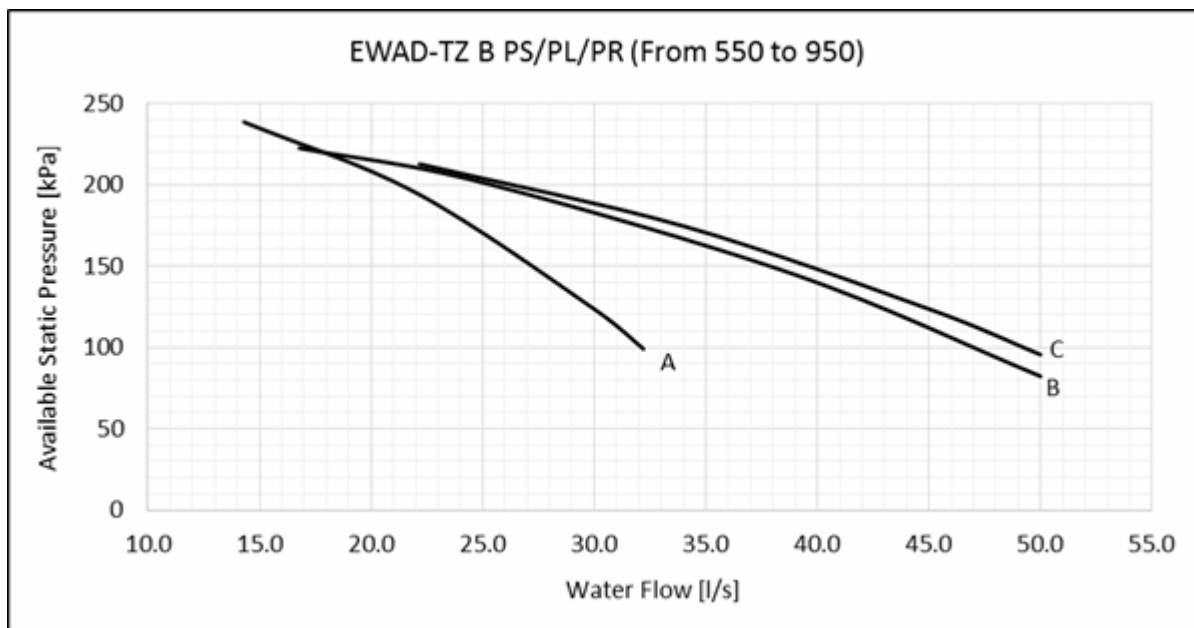

Technical data

Model			Pump motor power [kW]	Pump motor current [A]	Power Supply	PN	Motor Protection	Insulation Class	Working Temp.* [°C]	Max Amb Temp. [°C]	Ref. Curve
EWAD550TZPSB2	EWAD550TZPLB2	EWAD550TZPRB2	7.5	14.1	400V-3ph-50Hz	16	IP55	F	-25/120	40	A
EWAD620TZPSB2	EWAD620TZPLB2	EWAD620TZPRB2	7.5	14.1	400V-3ph-50Hz	16	IP55	F	-25/120	40	A
EWAD720TZPSB2	EWAD720TZPLB2	EWAD720TZPRB2	11	20.2	400V-3ph-50Hz	16	IP55	F	-25/120	40	B
EWAD820TZPSB2	EWAD820TZPLB2	EWAD820TZPRB2	11	20.2	400V-3ph-50Hz	16	IP55	F	-25/120	40	B
EWAD950TZPSB2	EWAD950TZPLB2	EWAD950TZPRB2	11	20.2	400V-3ph-50Hz	16	IP55	F	-25/120	40	C

Note: to calculate the total electrical data of the base unit selected with hydronic kit, the electrical data of the pump must be added to the electrical data of the base unit. Electrical data are subject to modification without notice. Please refer to unit nameplate.

Double pump high lift

EWAD TZ B SS/SL/SR (SILVER series) – Available static pressure - double pump high lift

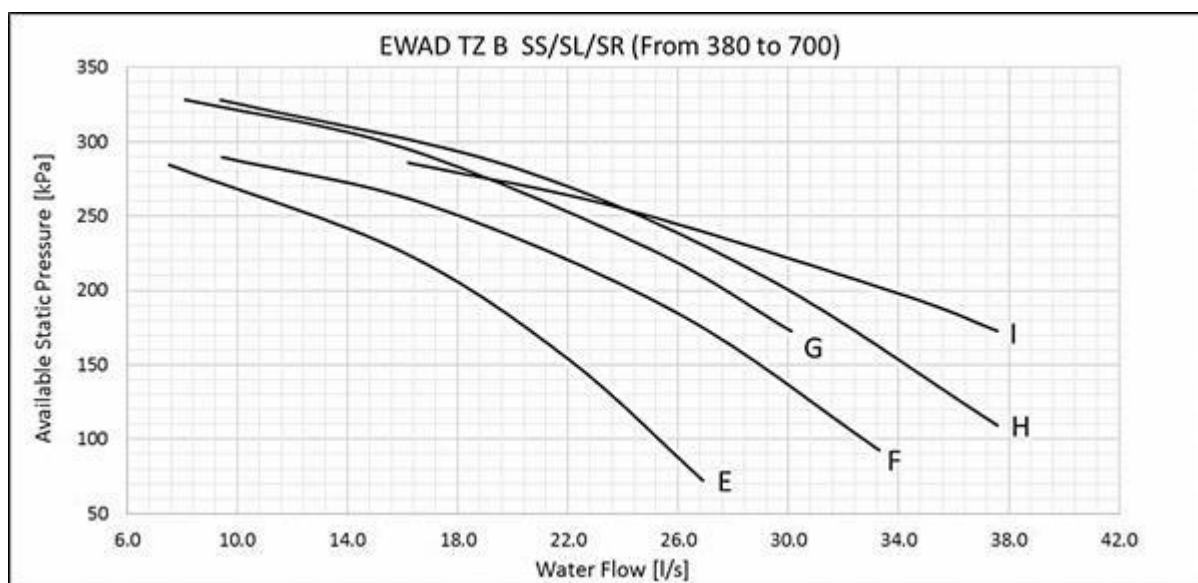
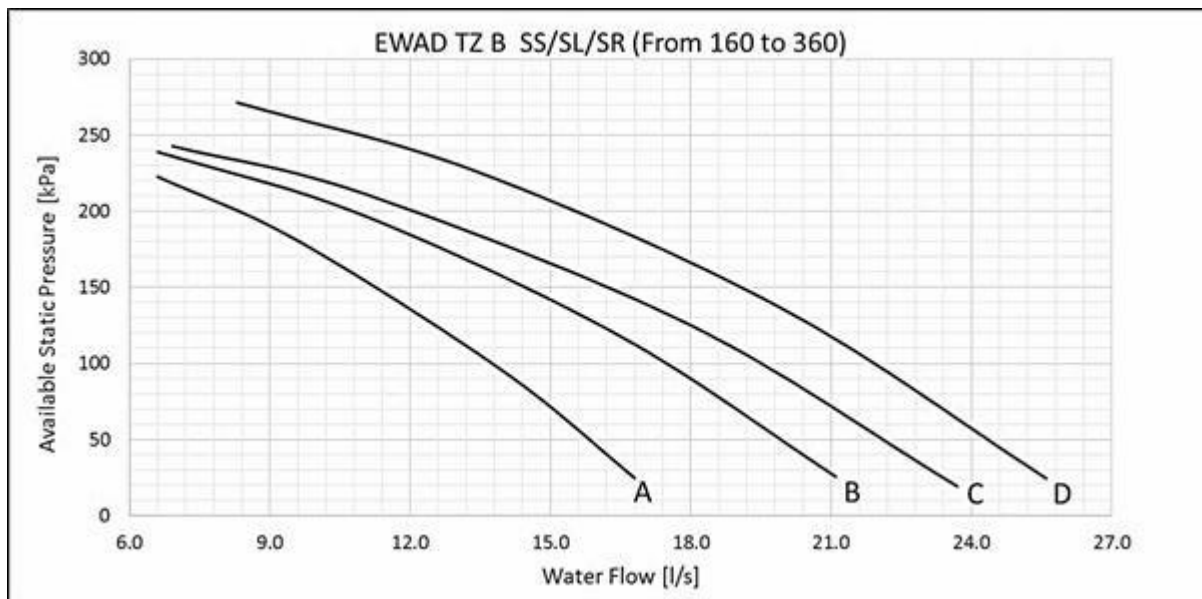

Technical data

	Model			Pump motor power [kW]	Pump motor current [A]	Power Supply	PN	Motor Protection	Insulation Class	Working temperature* [°C]	Max Ambient temperature [°C]	Ref. Curve
Single circuit	EWAD160TZ.S3B1	EWAD160TZSLB1	EWAD160TZSRB1	5.5	10.5	400V-3ph-50Hz	16	IP55	F	-25/120	40	A
	EWAD190TZ.S3B1	EWAD190TZSLB1	EWAD190TZSRB1	5.5	10.5	400V-3ph-50Hz	16	IP55	F	-25/120	40	B
	EWAD240TZ.S3B1	EWAD240TZSLB1	EWAD240TZSRB1	5.5	10.5	400V-3ph-50Hz	16	IP55	F	-25/120	40	C
	EWAD270TZ.S3B1	EWAD270TZSLB1	EWAD270TZSRB1	5.5	10.5	400V-3ph-50Hz	16	IP55	F	-25/120	40	B
	EWAD300TZ.S3B1	EWAD300TZSLB1	EWAD300TZSRB1	7.5	14.1	400V-3ph-50Hz	16	IP55	F	-25/120	40	D
Dual circuit	EWAD360TZ.S3B1	EWAD360TZSLB1	EWAD360TZSRB1	7.5	14.1	400V-3ph-50Hz	16	IP55	F	-25/120	40	D
	EWAD380TZ.S3B2	EWAD380TZSLB2	EWAD380TZSRB2	7.5	14.1	400V-3ph-50Hz	16	IP55	F	-25/120	40	E
	EWAD450TZ.S3B2	EWAD450TZSLB2	EWAD450TZSRB2	9.2	17.2	400V-3ph-50Hz	16	IP55	F	-25/120	40	F
	EWAD495TZ.S3B2	EWAD495TZSLB2	EWAD495TZSRB2	11	20.2	400V-3ph-50Hz	16	IP55	F	-25/120	40	G
	EWAD570TZ.S3B2	EWAD570TZSLB2	EWAD570TZSRB2	11	20.2	400V-3ph-50Hz	16	IP55	F	-25/120	40	G
	EWAD610TZ.S3B2	EWAD610TZSLB2	EWAD610TZSRB2	11	20.2	400V-3ph-50Hz	16	IP55	F	-25/120	40	H
	EWAD660TZ.S3B2	EWAD660TZSLB2	EWAD660TZSRB2	15	26.6	400V-3ph-50Hz	16	IP55	F	-25/120	40	I
	EWAD700TZ.S3B2	EWAD700TZSLB2	EWAD700TZSRB2	15	26.6	400V-3ph-50Hz	16	IP55	F	-25/120	40	I

Note: to calculate the total electrical data of the base unit selected with hydronic kit, the electrical data of the pump must be added to the electrical data of the base unit. Electrical data are subject to modification without notice. Please refer to unit nameplate.

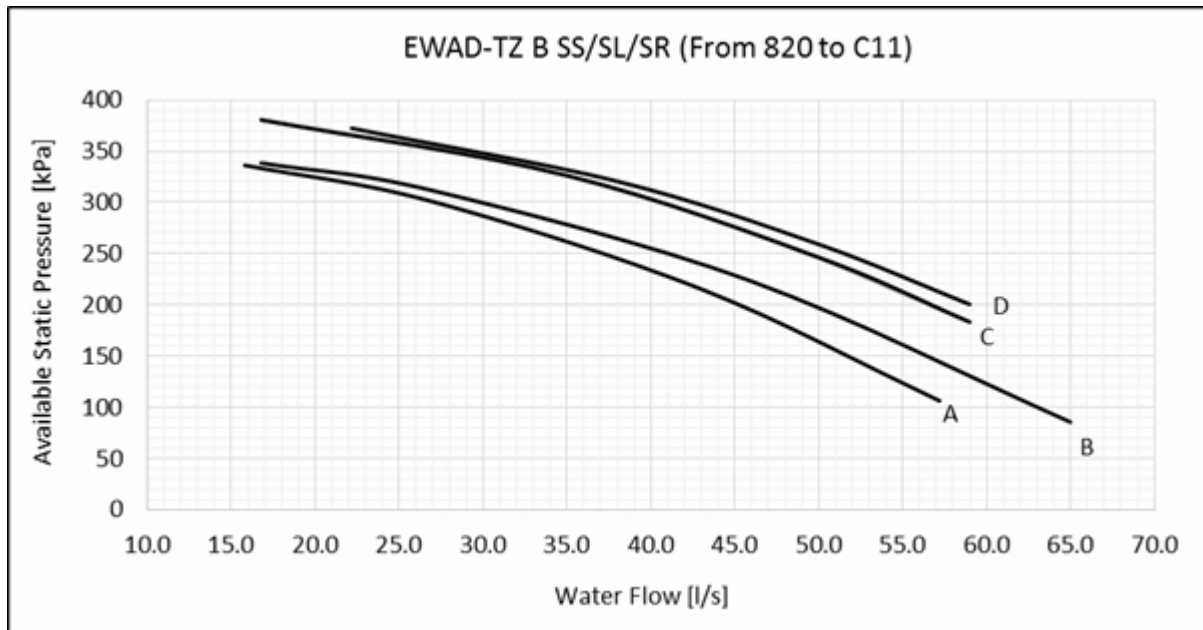

Technical data

Model			Pump motor power [kW]	Pump motor current [A]	Power Supply	PN	Motor Protection	Insulation Class	Working Temp.* [°C]	Max Amb Temp. [°C]	Ref. Curve
EWAD820TZSSB2	EWAD820TZSLB2	EWAD820TZSRB2	18.5	32.7	400V-3ph-50Hz	16	IP55	F	-25/120	40	A
EWAD900TZSSB2	EWAD900TZSLB2	EWAD900TZSRB2	18.5	32.7	400V-3ph-50Hz	16	IP55	F	-25/120	40	B
EWAD990TZSSB2	EWAD990TZSLB2	EWAD990TZSRB2	22	42.2	400V-3ph-50Hz	16	IP55	F	-25/120	40	C
EWADC10TZSSB2	EWADC10TZSLB2	EWADC10TZSRB2	22	42.2	400V-3ph-50Hz	16	IP55	F	-25/120	40	C
EWADC11TZSSB2	EWADC11TZSLB2	EWADC11TZSRB2	22	42.2	400V-3ph-50Hz	16	IP55	F	-25/120	40	D

Note: to calculate the total electrical data of the base unit selected with hydronic kit, the electrical data of the pump must be added to the electrical data of the base unit. Electrical data are subject to modification without notice. Please refer to unit nameplate.

EWAD TZ B XS/XL/XR (GOLD series) – Available static pressure - double pump high lift

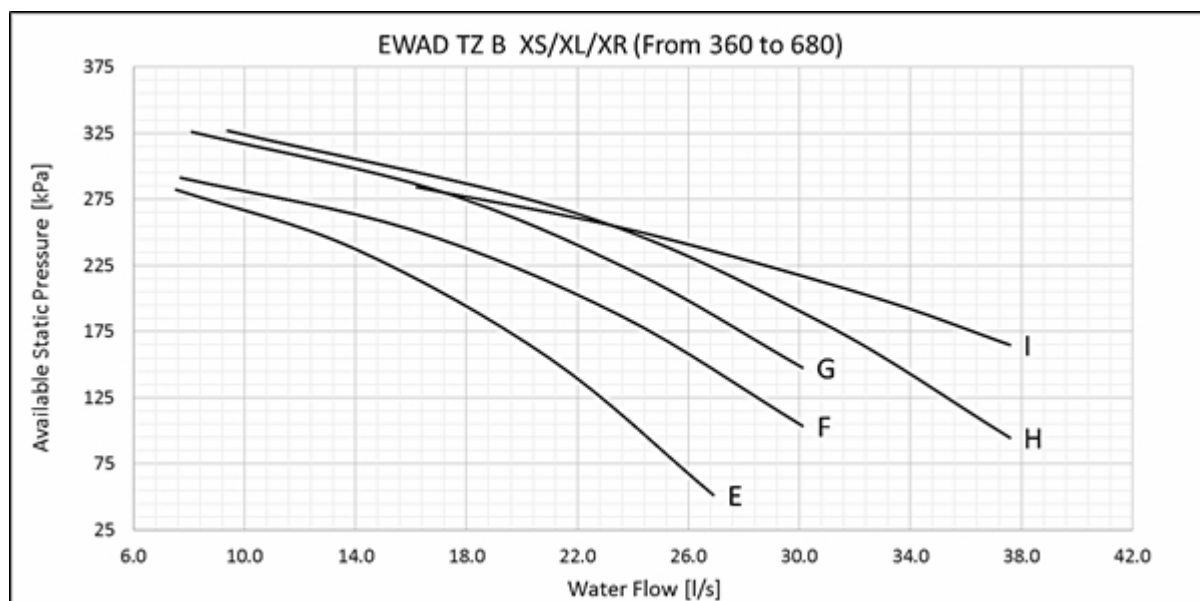
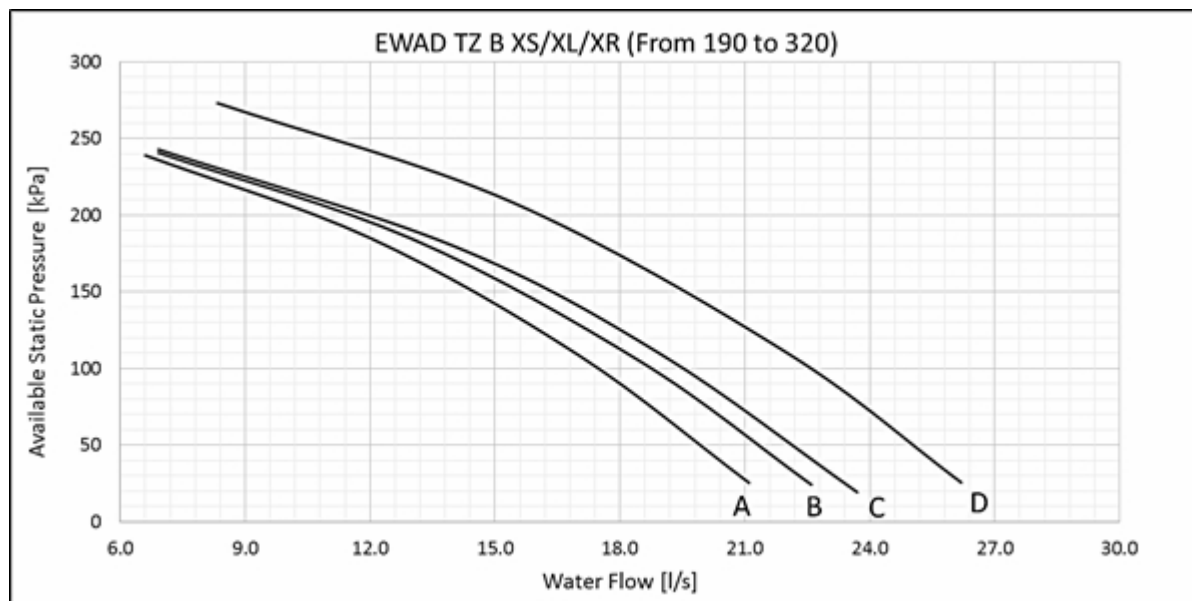

Technical data

	Model			Pump motor power [kW]	Pump motor current [A]	Power Supply	PN	Motor Protection	Insulation Class	Working temperature * [°C]	Max Ambient temperature [°C]	Ref. Curve
Single circuit	EWAD190TZ.XSB1	EWAD190TZ.XLB1	EWAD190TZ.XRB1	5.5	10.5	400V-3ph-50Hz	16	IP55	F	-25/120	40	A
	EWAD220TZ.XSB1	EWAD220TZ.XLB1	EWAD220TZ.XRB1	5.5	10.5	400V-3ph-50Hz	16	IP55	F	-25/120	40	B
	EWAD240TZ.XSB1	EWAD240TZ.XLB1	EWAD240TZ.XRB1	5.5	10.5	400V-3ph-50Hz	16	IP55	F	-25/120	40	C
	EWAD290TZ.XSB1	EWAD290TZ.XLB1	EWAD290TZ.XRB1	5.5	10.5	400V-3ph-50Hz	16	IP55	F	-25/120	40	C
	EWAD320TZ.XSB1	EWAD320TZ.XLB1	EWAD320TZ.XRB1	7.5	14.1	400V-3ph-50Hz	16	IP55	F	-25/120	40	D
Dual circuit	EWAD360TZ.XSB2	EWAD360TZ.XLB2	EWAD360TZ.XRB2	7.5	14.1	400V-3ph-50Hz	16	IP55	F	-25/120	40	E
	EWAD420TZ.XSB2	EWAD420TZ.XLB2	EWAD420TZ.XRB2	9.2	17.2	400V-3ph-50Hz	16	IP55	F	-25/120	40	F
	EWAD450TZ.XSB2	EWAD450TZ.XLB2	EWAD450TZ.XRB2	11	20.2	400V-3ph-50Hz	16	IP55	F	-25/120	40	G
	EWAD540TZ.XSB2	EWAD540TZ.XLB2	EWAD540TZ.XRB2	11	20.2	400V-3ph-50Hz	16	IP55	F	-25/120	40	H
	EWAD570TZ.XSB2	EWAD570TZ.XLB2	EWAD570TZ.XRB2	11	20.2	400V-3ph-50Hz	16	IP55	F	-25/120	40	H
	EWAD610TZ.XSB2	EWAD610TZ.XLB2	EWAD610TZ.XRB2	11	20.2	400V-3ph-50Hz	16	IP55	F	-25/120	40	H
	EWAD660TZ.XSB2	EWAD660TZ.XLB2	EWAD660TZ.XRB2	11	20.2	400V-3ph-50Hz	16	IP55	F	-25/120	40	H
	EWAD680TZ.XSB2	EWAD680TZ.XLB2	EWAD680TZ.XRB2	15	28.6	400V-3ph-50Hz	16	IP55	F	-25/120	40	I

Note: to calculate the total electrical data of the base unit selected with hydronic kit, the electrical data of the pump must be added to the electrical data of the base unit. Electrical data are subject to modification without notice. Please refer to unit nameplate.

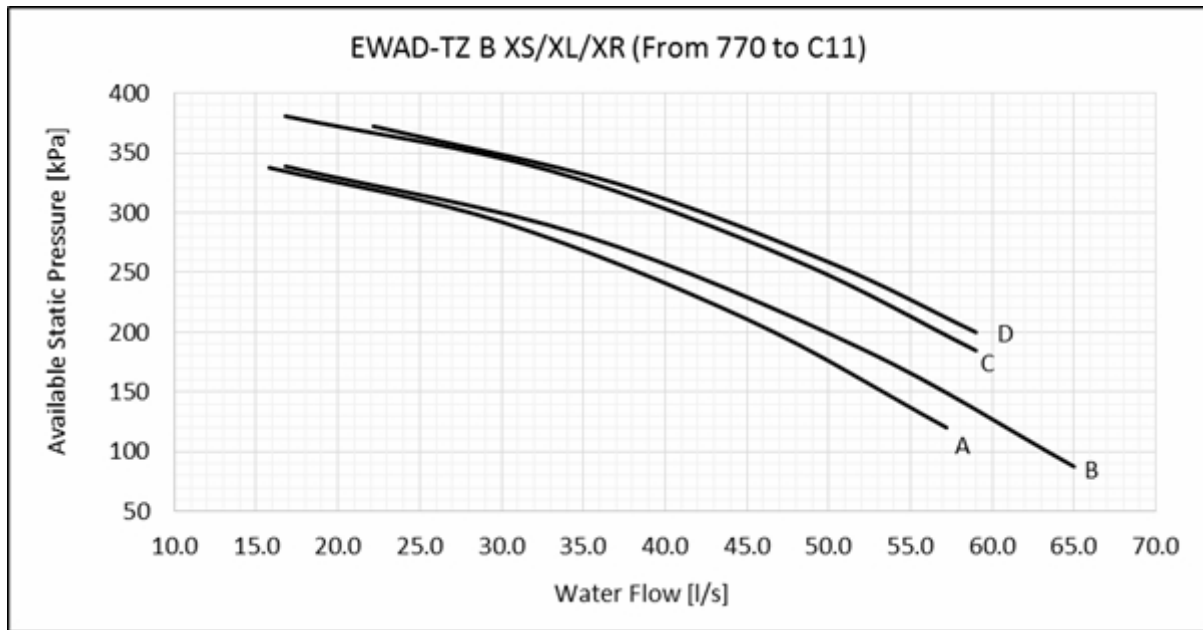

Technical data

Model			Pump motor power [kW]	Pump motor current [A]	Power Supply	PN	Motor Protection	Insulation Class	Working Temp.* [°C]	Max Amb Temp. [°C]	Ref. Curve
EWAD770TZXS2	EWAD770TZXL2	EWAD770TZXR2	18.5	32.7	400V-3ph-50Hz	16	IP55	F	-25/120	40	A
EWAD850TZXS2	EWAD850TZXL2	EWAD850TZXR2	18.5	32.7	400V-3ph-50Hz	16	IP55	F	-25/120	40	B
EWAD910TZXS2	EWAD910TZXL2	EWAD910TZXR2	18.5	32.7	400V-3ph-50Hz	16	IP55	F	-25/120	40	B
EWADC10TZXS2	EWADC10TZXL2	EWADC10TZXR2	22	42.2	400V-3ph-50Hz	16	IP55	F	-25/120	40	C
EWADC11TZXS2	EWADC11TZXL2	EWADC11TZXR2	22	42.2	400V-3ph-50Hz	16	IP55	F	-25/120	40	D

Note: to calculate the total electrical data of the base unit selected with hydronic kit, the electrical data of the pump must be added to the electrical data of the base unit. Electrical data are subject to modification without notice. Please refer to unit nameplate.

EWAD TZ B PS/PL/PR (PLATINUM series) – Available static pressure - double pump low lift

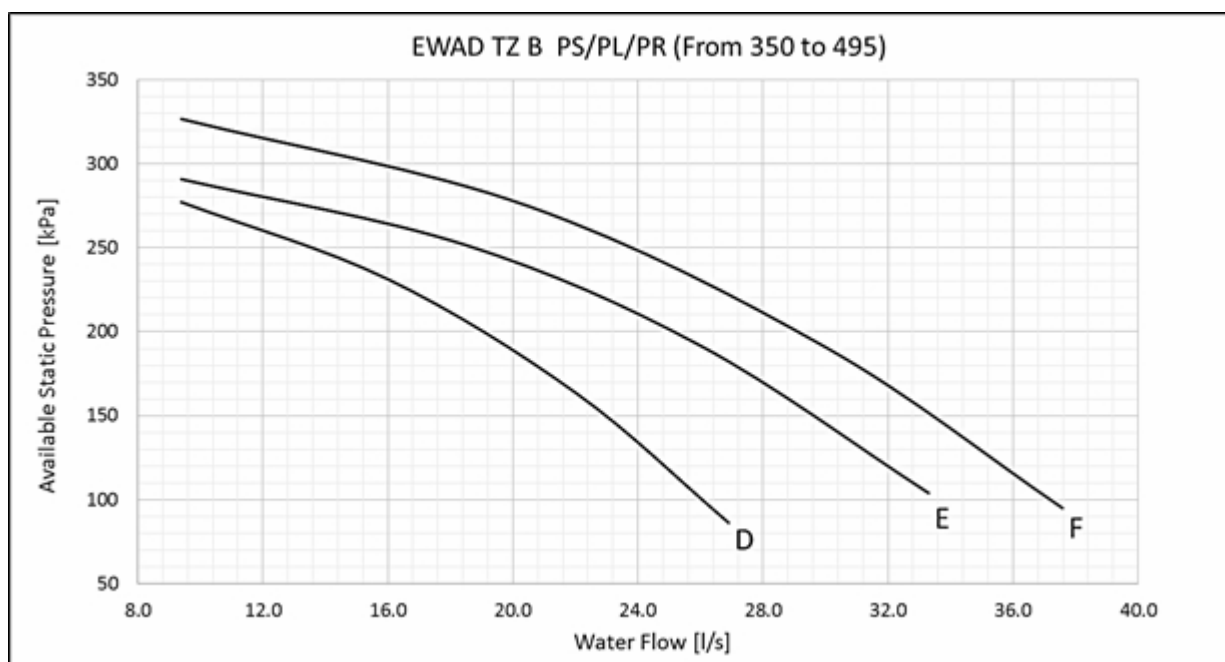
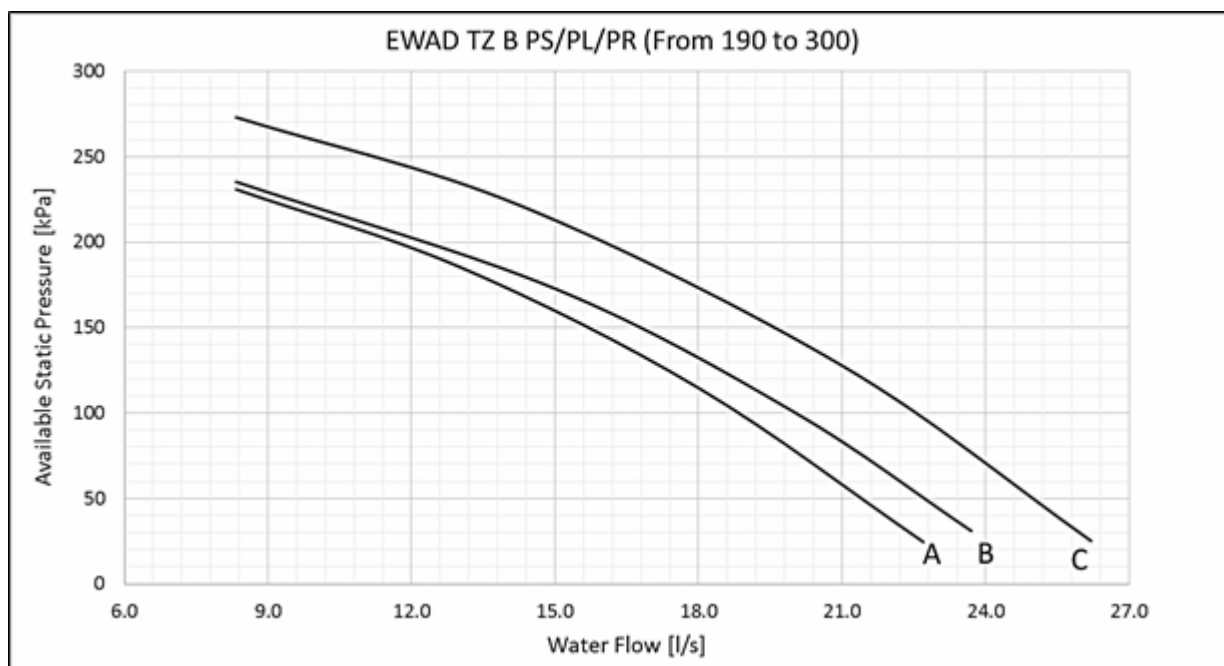

Technical data

	Model			Pump motor power [kW]	Pump motor current [A]	Power Supply	PN	Motor Protection	Insulation Class	Working temperature* [°C]	Max Ambient temperature [°C]	Ref. Curve
Single circuit	EWAD190TZP SB1	EWAD190TZ PLB1	EWAD190TZPR B1	5.5	10.5	400V-3ph-50Hz	16	IP55	F	-25/120	40	A
	EWAD220TZP SB1	EWAD220TZ PLB1	EWAD220TZPR B1	5.5	10.5	400V-3ph-50Hz	16	IP55	F	-25/120	40	A
	EWAD240TZP SB1	EWAD240TZ PLB1	EWAD240TZPR B1	5.5	10.5	400V-3ph-50Hz	16	IP55	F	-25/120	40	B
	EWAD290TZP SB1	EWAD290TZ PLB1	EWAD290TZPR B1	5.5	10.5	400V-3ph-50Hz	16	IP55	F	-25/120	40	B
	EWAD300TZP SB1	EWAD300TZ PLB1	EWAD300TZPR B1	7.5	14.1	400V-3ph-50Hz	16	IP55	F	-25/120	40	C
Dual circuit	EWAD350TZP SB2	EWAD350TZ PLB2	EWAD350TZPR B2	7.5	14.1	400V-3ph-50Hz	16	IP55	F	-25/120	40	D
	EWAD420TZP SB2	EWAD420TZ PLB2	EWAD420TZPR B2	9.2	17.2	400V-3ph-50Hz	16	IP55	F	-25/120	40	E
	EWAD495TZP SB2	EWAD495TZ PLB2	EWAD495TZPR B2	11	20.2	400V-3ph-50Hz	16	IP55	F	-25/120	40	F

Note: to calculate the total electrical data of the base unit selected with hydronic kit, the electrical data of the pump must be added to the electrical data of the base unit. Electrical data are subject to modification without notice. Please refer to unit nameplate.

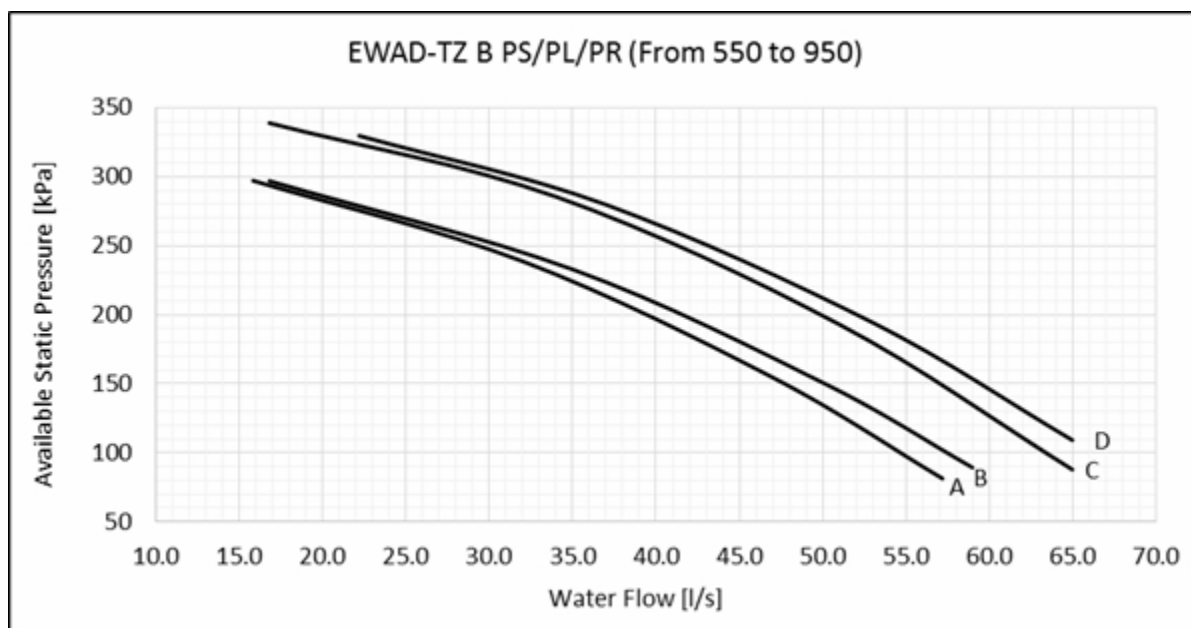

Technical data

Model			Pump motor power [kW]	Pump motor current [A]	Power Supply	PN	Motor Protection	Insulation Class	Working Temp.* [°C]	Max Amb Temp. [°C]	Ref. Curve
EWAD550TZPSB2	EWAD550TZPLB2	EWAD550TZPRB2	15	26.6	400V-3ph-50Hz	16	IP55	F	-25/120	40	A
EWAD620TZPSB2	EWAD620TZPLB2	EWAD620TZPRB2	15	26.6	400V-3ph-50Hz	16	IP55	F	-25/120	40	A
EWAD720TZPSB2	EWAD720TZPLB2	EWAD720TZPRB2	15	26.6	400V-3ph-50Hz	16	IP55	F	-25/120	40	B
EWAD820TZPSB2	EWAD820TZPLB2	EWAD820TZPRB2	18.5	32.7	400V-3ph-50Hz	16	IP55	F	-25/120	40	C
EWAD950TZPSB2	EWAD950TZPLB2	EWAD950TZPRB2	18.5	32.7	400V-3ph-50Hz	16	IP55	F	-25/120	40	D

Note: to calculate the total electrical data of the base unit selected with hydronic kit, the electrical data of the pump must be added to the electrical data of the base unit. Electrical data are subject to modification without notice. Please refer to unit nameplate.

NOTE:

The above curves refers to the available static pressure taking into account the pressure drops in the heat exchanger, units piping and filters. the pressure drop across the filter is considered only for single circuit units which are provided as standard with filter (the filter is shipped loose).

In case where the filter provided from factory is replaced with other type of filters the above curves are not applicable. For dual circuit units the curves are not considering the pressure drop for the filter (which is not provided by factory). The installation of the filter for single and dual circuit units is mandatory.

How to calculate the overall chiller water side pressure drops (pump by others)

In order to calculate the overall pressure drops introduced by the chiller in an installation the following points have to be considered:

Overall chiller pressure drops = evaporator [kPa] + Filter pressure drop [kPa]

- Select the chiller with CSS tool, you get easily the design water flow rate and the corresponding 'evaporator pressure drops' value (in CSS tool kPa figures are referred to evaporator only).
- Refer to "Specification" chapter or unit dimensional drawing to check the water connection diameters (equal to filters size).
- Considering the design flow rate and water filter size and piping diameter, from graph "Filter pressure drops" get the corresponding kPa value.
- By adding the values at point "a" and "c", 'Overall chiller pressure drops' figure is got.

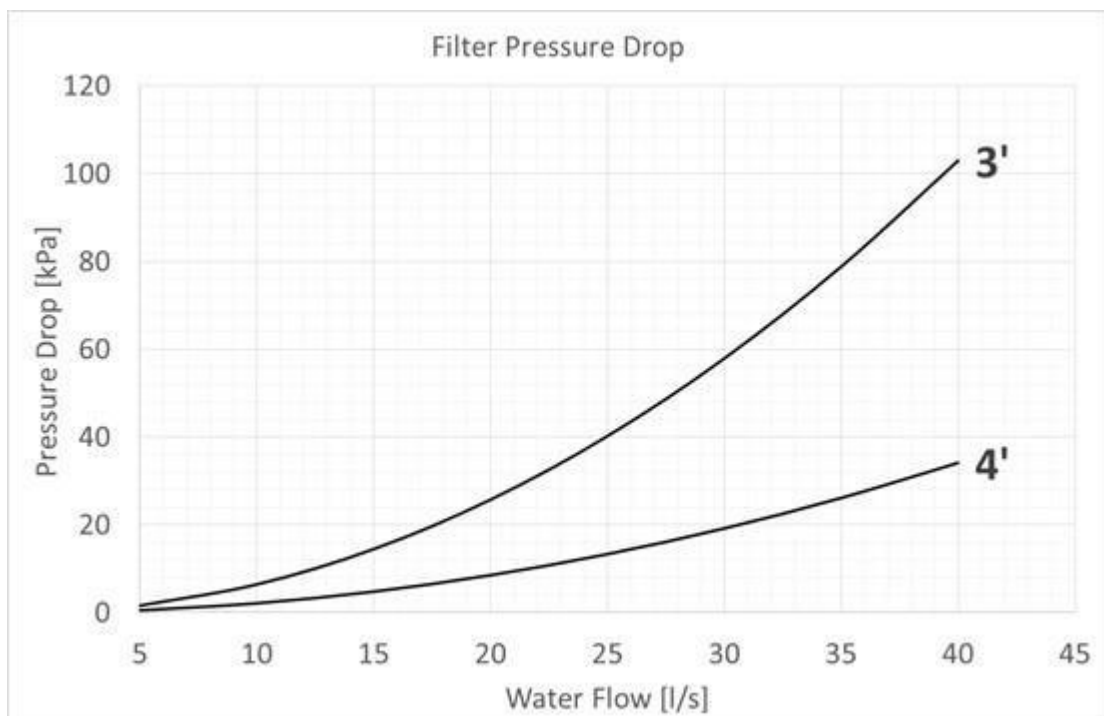

In case where the filter provided from factory is replaced with other type of filters the above curves are not applicable.

The installation of the filter for single and dual circuit units is mandatory.

The pressure drop value showed in CSS (Chiller Selection Software) are referred to chiller's evaporator only.

For EWAD~TZB factory provides the water filter as standard option only for single circuit unit.

The filters is shipped loose

Note: when using mixture of water and glycol please contact factory as above specification could change.

Hydraulic scheme

Single circuit unit without hydronic kit

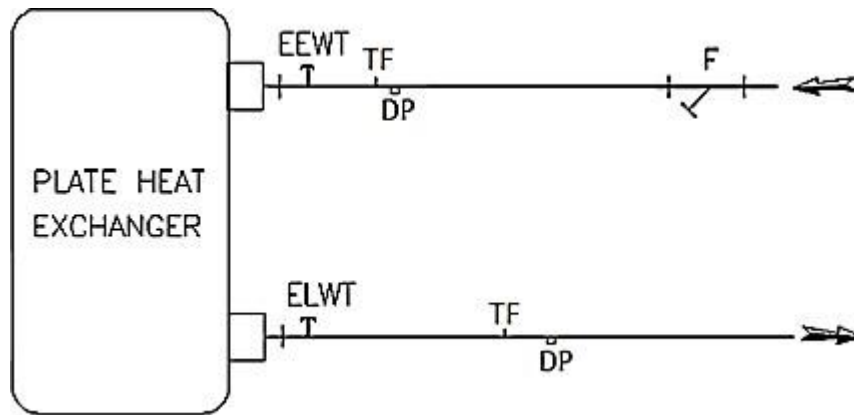

F	Y-TYPE STRAINER (shipped lose)	EEWT	EVAPOR. ENTERING WATER TEMPERATURE PROBE
DP	DRAIN PLUG	ELWT	EVAPOR. LEAVING WATER TEMPERATURE PROBE
TF	THREADED FITTING		

Dual circuit unit without hydronic kit

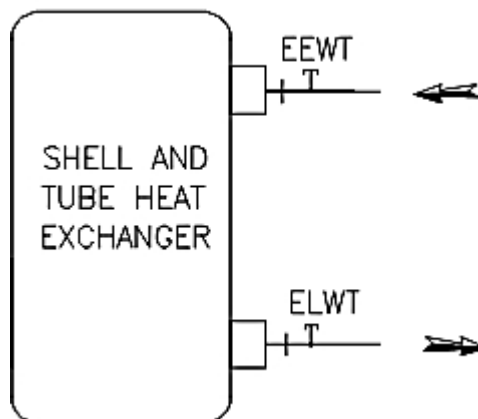

EEWT PROBE	EVAPOR. ENTERING WATER TEMPERATURE PROBE	EEWT	EVAPOR. LEAVING WATER TEMPERATURE PROBE
---------------	---	------	--

Note: drain plug and threaded fitting are on the shell and tube exchanger

Single circuit unit with single pump low/high lift

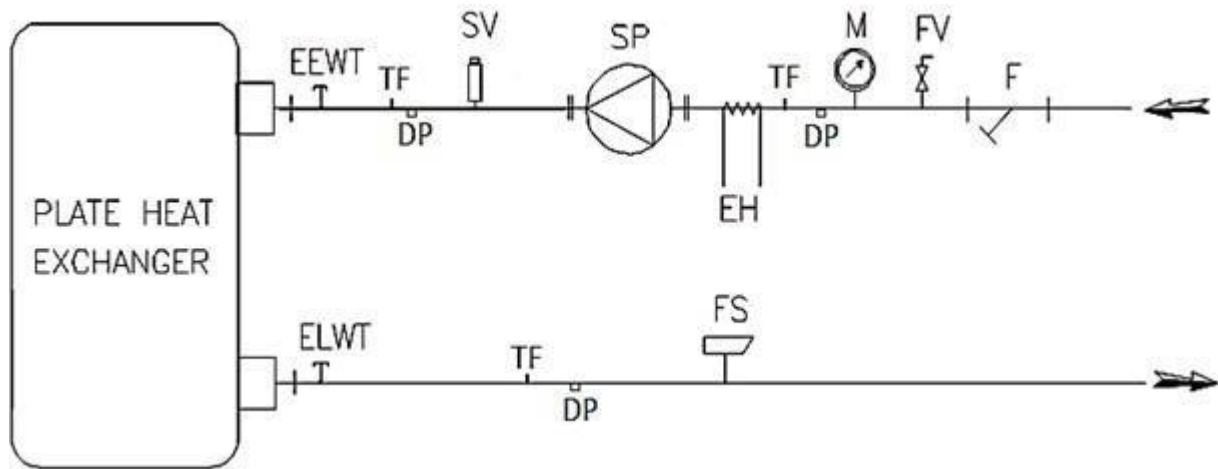

F	Y-TYPE STRAINER (shipped lose)	SP	IN LINE SINGLE PUMP
FV	FILLING VALVE	SV	SAFETY VALVE
M	PRESSURE GAUGE	EEWT	EVAPOR. ENTERING WATER TEMPERATURE PROBE
DP	DRAIN PLUG	EEWT	EVAPOR. LEAVING WATER TEMPERATURE PROBE
TF	THREADED FITTING	FS	FLOW SWITCH *
EH	ELECTRIC HEATER/THERMOSTAT		

*Flow switch available as option (opt. code 58)
safety valve set at 10 bar

Dual circuit unit with single pump low/high lift

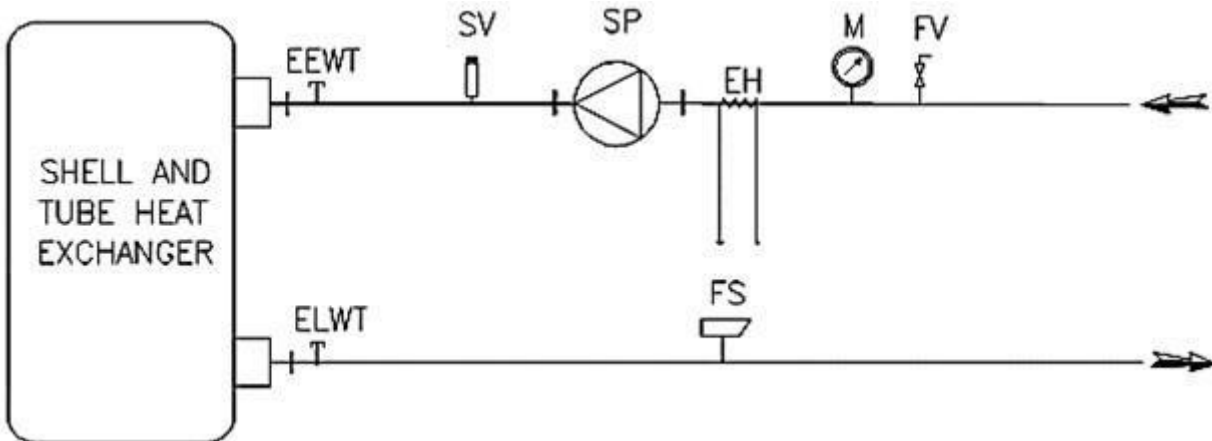

FV	FILLING VALVE	SV	SAFETY VALVE
M	PRESSURE GAUGE	EEWT	EVAPOR. ENTERING WATER TEMPERATURE PROBE
EH	ELECTRIC HEATER/ THERMOSTAT	EEWT	EVAPOR. LEAVING WATER TEMPERATURE PROBE
SP	IN LINE SINGLE PUMP	FS	FLOW SWITCH *

*Flow switch available as option (opt. code 58)
safety valve set at 10 bar
Note: drain plug and threaded fitting are on the shell and tube exchanger

Single circuit unit with dual pump low/high lift

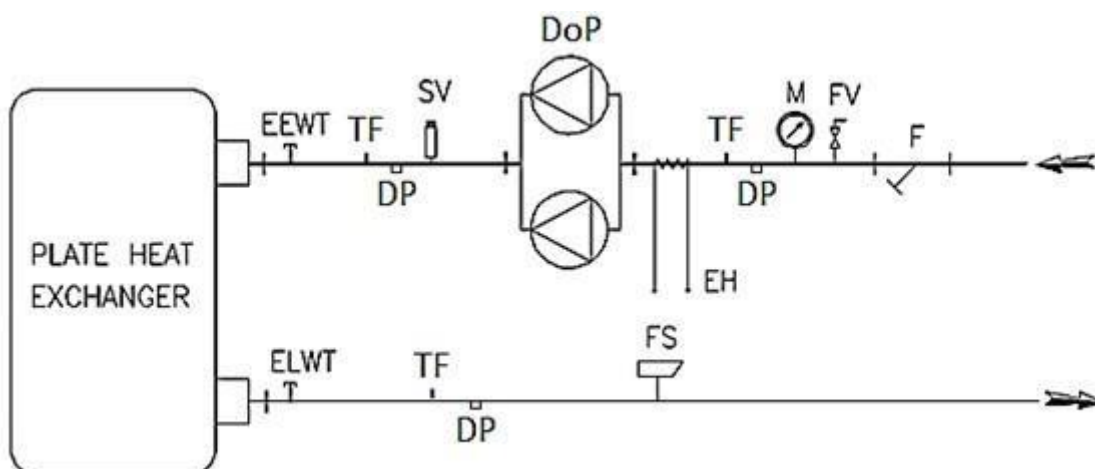

F	Y-TYPE STRAINER (shipped lose)	DoP	IN LINE DOUBLE PUMP
FV	FILLING VALVE	SV	SAFETY VALVE
M	PRESSURE GAUGE	EEWT	EVAPOR. ENTERING WATER TEMPERATURE PROBE
DP	DRAIN PLUG	EEWT	EVAPOR. LEAVING WATER TEMPERATURE PROBE
TF	THREADED FITTING	FS	FLOW SWITCH *
EH	ELECTRIC HEATER/THERMOSTAT		

*Flow switch available as option (opt. code 58)

safety valve set at 10 bar

Dual circuit unit with dual pump low/high lift

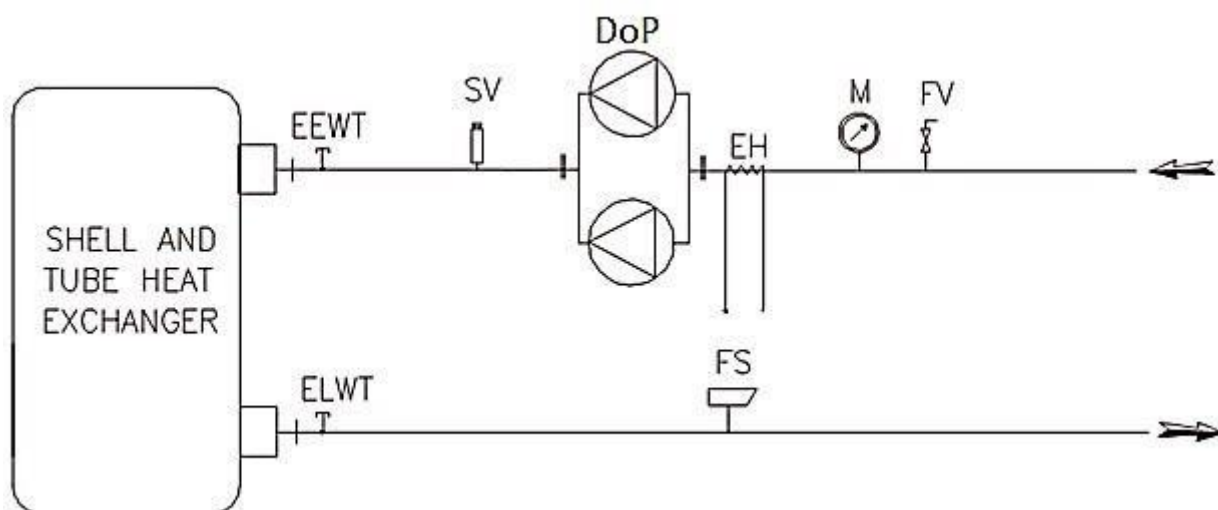

FV	FILLING VALVE	SV	SAFETY VALVE
M	PRESSURE GAUGE	EEWT	EVAPOR. ENTERING WATER TEMPERATURE PROBE
EH	ELECTRIC HEATER/ THERMOSTAT	EEWT	EVAPOR. LEAVING WATER TEMPERATURE PROBE
DoP	IN LINE DOUBLE PUMP	FS	FLOW SWITCH *

*Flow switch available as option (opt. code 58)

safety valve set at 10 bar

Note: drain plug and threaded fitting are on the shell and tube exchanger

Water piping

The water system must have:

1. Anti-vibration joint in order to reduce transmission of vibrations to the structures.
2. Isolating valves to isolate the unit from the water system during maintenance.
3. Flow switch.
4. Manual or automatic air venting device at the system's highest point.; drain device at the system's lowest point.
5. A suitable device that can maintain the water system under pressure (expansion tank, etc.).
6. Water temperature and pressure indicators to assist the operator during service and maintenance.
7. A filter or device that can remove particles from the fluid. The installation of the filter is mandatory. The use of a filter extends the life of the evaporator and pump and helps to keep the water system in a better condition. The water filter must be installed as close as possible to the chiller. If the water filter is installed in another part of the water system, the installer has to guarantee the cleaning of the water pipes between the water filter and the evaporator. The water used for filling the water circuit must be clean and suitably treated.
8. Precautions should be provided to protect the unit against freezing.
9. The heat recovery device must be emptied of water during the winter season, unless an ethylene glycol mixture in appropriate percentage is added to the water circuit.
10. In case of unit substitution, the entire water system must be emptied and cleaned before the new unit is installed. Regular tests and proper chemical treatment of water are recommended after starting up the new unit.
11. In the event that glycol is added to the water system as anti-freeze protection, pay attention to the fact that suction pressure will be lower, the unit's performance will be lower and water pressure drops will be greater. All unit-protection systems, such as anti-freeze, and low-pressure protection will need to be readjusted.
12. Before insulating water piping, check that there are no leaks.

SINGLE CIRCUIT -B1

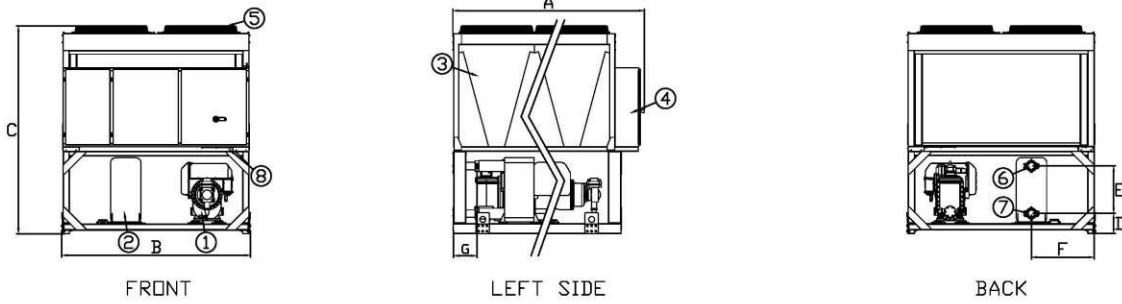

DUAL CIRCUIT -B2

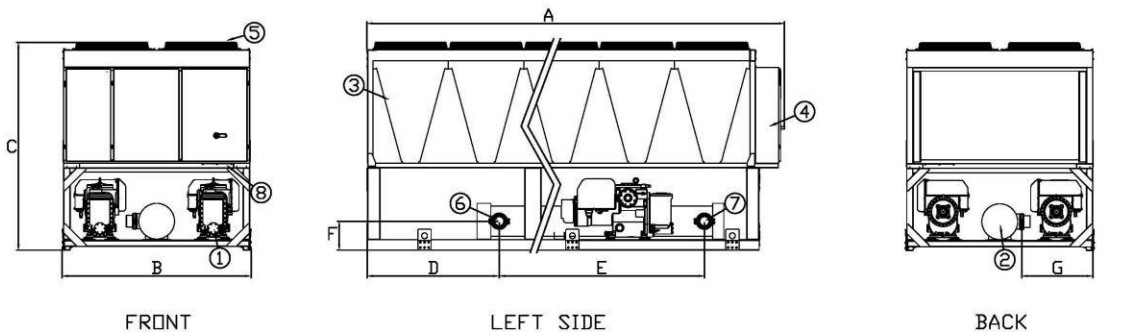

LEGEND

- 1. COMPRESSOR
- 2. EVAPORATOR
- 3. CONDENSER COIL
- 4. ELECTRICAL PANEL
- 5. FAN
- 6. EVAPORATOR WATER INLET
- 7. EVAPORATOR WATER OUTLET
- 8. SLOT FOR POWER AND CONTROL PANEL CONNCTION

note:

the above drawings are not contractually binding. For the design of installation refer to the dedicated dimensional drawing available from the factory on request. The data are subject to change without notice.

MODEL	A	B	C
EWAD160TZ-SS B1	2331	2282	2540
EWAD190TZ-SS B1	2331	2282	2540
EWAD240TZ-SS B1	2331	2282	2540
EWAD270TZ-SS B1	3231	2282	2540
EWAD300TZ-SS B1	3231	2282	2540
EWAD360TZ-SS B1	4131	2282	2540
EWAD380TZ-SS B2	4131	2282	2540
EWAD450TZ-SS B2	4131	2282	2540
EWAD495TZ-SS B2	5030	2282	2540
EWAD570TZ-SS B2	5887	2282	2540
EWAD610TZ-SS B2	5887	2282	2540
EWAD660TZ-SS B2	5887	2282	2540
EWAD700TZ-SS B2	6786	2282	2540
EWAD820TZ-SS B2	6877	2282	2540
EWAD900TZ-SS B2	6877	2282	2540
EWAD990TZ-SS B2	7787	2282	2540
EWADC10TZ-SS B2	9587	2282	2540
EWADC11TZ-SS B2	10488	2282	2540

SINGLE CIRCUIT -B1

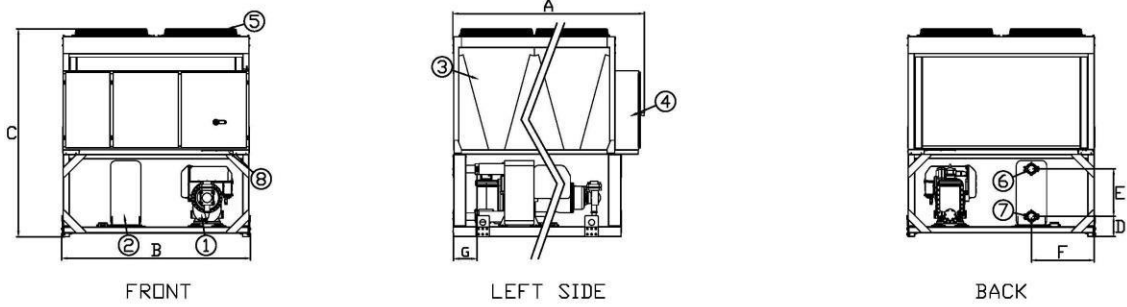

DUAL CIRCUIT -B2

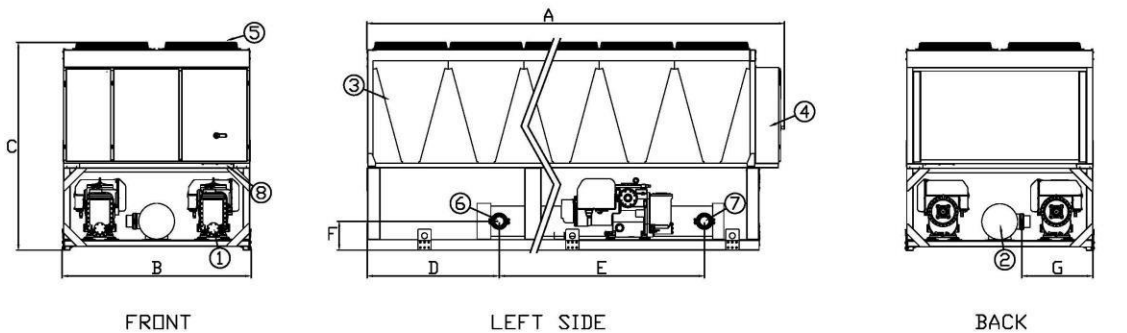

LEGEND

- 1. COMPRESSOR
- 2. EVAPORATOR
- 3. CONDENSER COIL
- 4. ELECTRICAL PANEL
- 5. FAN
- 6. EVAPORATOR WATER INLET
- 7. EVAPORATOR WATER OUTLET
- 8. SLOT FOR POWER AND CONTROL PANEL CONNCTION

note:

the above drawings are not contractually binding. For the design of installation refer to the dedicated dimensional drawing available from the factory on request. The data are subject to change without notice.

MODEL	A	B	C
EWAD160TZ-SL B1	2331	2282	2540
EWAD190TZ-SL B1	2331	2282	2540
EWAD240TZ-SL B1	2331	2282	2540
EWAD270TZ-SL B1	3231	2282	2540
EWAD300TZ-SL B1	3231	2282	2540
EWAD360TZ-SL B1	4131	2282	2540
EWAD380TZ-SL B2	4131	2282	2540
EWAD450TZ-SL B2	4131	2282	2540
EWAD495TZ-SL B2	5030	2282	2540
EWAD570TZ-SL B2	5887	2282	2540
EWAD610TZ-SL B2	5887	2282	2540
EWAD660TZ-SL B2	5887	2282	2540
EWAD700TZ-SL B2	6786	2282	2540
EWAD820TZ-SL B2	6877	2282	2540
EWAD900TZ-SL B2	6877	2282	2540
EWAD990TZ-SL B2	7787	2282	2540
EWADC10TZ-SL B2	9587	2282	2540
EWADC11TZ-SL B2	10488	2282	2540

SINGLE CIRCUIT -B1

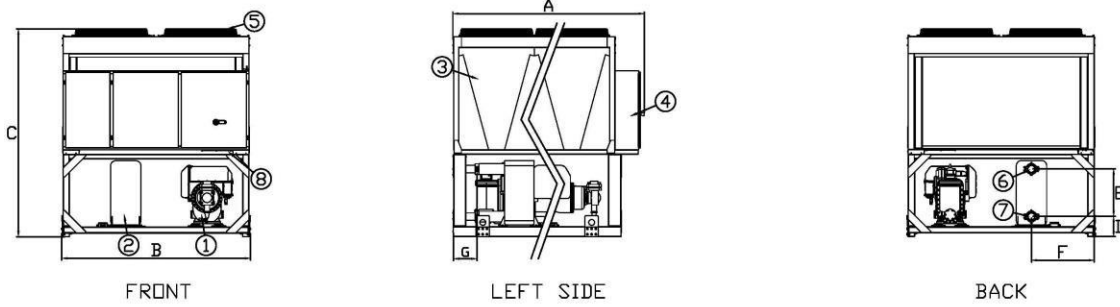

DUAL CIRCUIT -B2

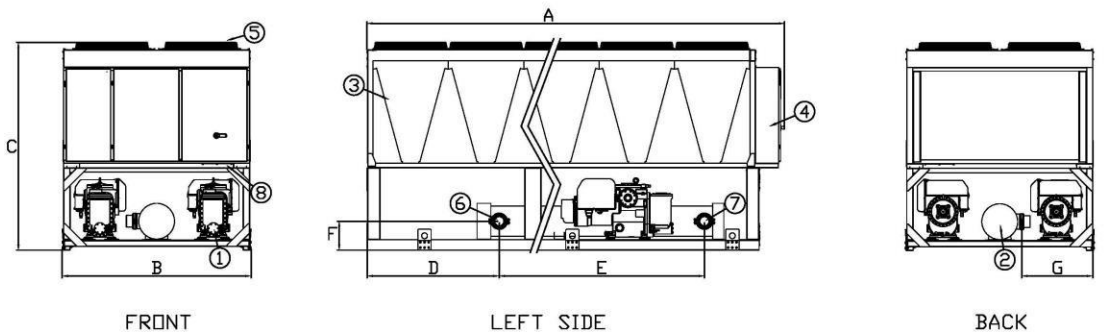

LEGEND

- 1. COMPRESSOR
- 2. EVAPORATOR
- 3. CONDENSER COIL
- 4. ELECTRICAL PANEL
- 5. FAN
- 6. EVAPORATOR WATER INLET
- 7. EVAPORATOR WATER OUTLET
- 8. SLOT FOR POWER AND CONTROL PANEL CONNCTION

note:

the above drawings are not contractually binding. For the design of installation refer to the dedicated dimensional drawing available from the factory on request. The data are subject to change without notice.

MODEL	A	B	C
EWAD160TZ-SR B1	2331	2282	2540
EWAD190TZ-SR B1	2331	2282	2540
EWAD240TZ-SR B1	2331	2282	2540
EWAD270TZ-SR B1	3231	2282	2540
EWAD300TZ-SR B1	3231	2282	2540
EWAD360TZ-SR B1	4131	2282	2540
EWAD380TZ-SR B2	4131	2282	2540
EWAD450TZ-SR B2	4131	2282	2540
EWAD495TZ-SR B2	5030	2282	2540
EWAD570TZ-SR B2	5887	2282	2540
EWAD610TZ-SR B2	5887	2282	2540
EWAD660TZ-SR B2	5887	2282	2540
EWAD700TZ-SR B2	6786	2282	2540
EWAD820TZ-SR B2	7787	2282	2540
EWAD900TZ-SR B2	7787	2282	2540
EWAD990TZ-SR B2	8687	2282	2540
EWADC10TZ-SR B2	9587	2282	2540
EWADC11TZ-SR B2	10488	2282	2540

SINGLE CIRCUIT -B1

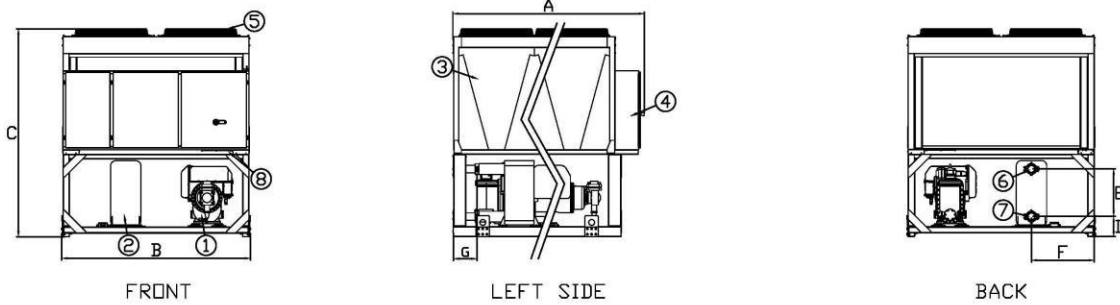

DUAL CIRCUIT -B2

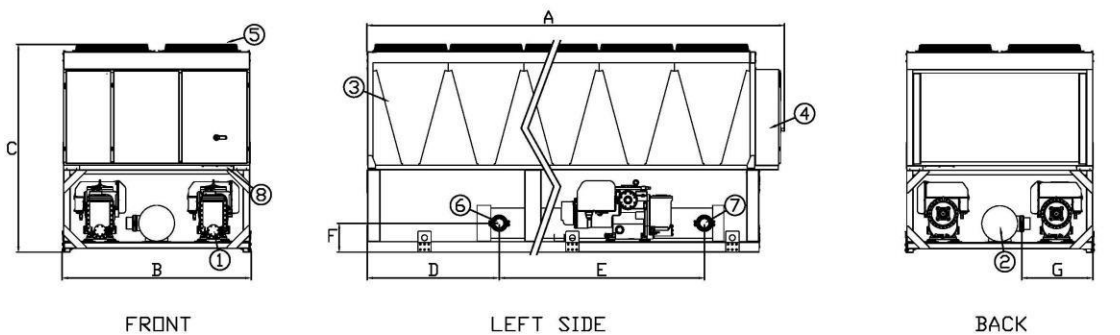

LEGEND

- 1. COMPRESSOR
- 2. EVAPORATOR
- 3. CONDENSER COIL
- 4. ELECTRICAL PANEL
- 5. FAN
- 6. EVAPORATOR WATER INLET
- 7. EVAPORATOR WATER OUTLET
- 8. SLOT FOR POWER AND CONTROL PANEL CONNCTION

note:

the above drawings are not contractually binding. For the design of installation refer to the dedicated dimensional drawing available from the factory on request. The data are subject to change without notice.

MODEL	A	B	C
EWAD190TZ-XS B1	3231	2282	2540
EWAD220TZ-XS B1	3231	2282	2540
EWAD240TZ-XS B1	3231	2282	2540
EWAD290TZ-XS B1	4131	2282	2540
EWAD320TZ-XS B1	4131	2282	2540
EWAD360TZ-XS B2	5030	2282	2540
EWAD420TZ-XS B2	5030	2282	2540
EWAD450TZ-XS B2	5887	2282	2540
EWAD540TZ-XS B2	5887	2282	2540
EWAD570TZ-XS B2	5887	2282	2540
EWAD610TZ-XS B2	6786	2282	2540
EWAD660TZ-XS B2	7684	2282	2540
EWAD680TZ-XS B2	7684	2282	2540
EWAD770TZ-XS B2	7787	2282	2540
EWAD850TZ-XS B2	7787	2282	2540
EWAD910TZ-XS B2	8687	2282	2540
EWADC10TZ-XS B2	9587	2282	2540
EWADC11TZ-XS B2	10488	2282	2540

SINGLE CIRCUIT -B1

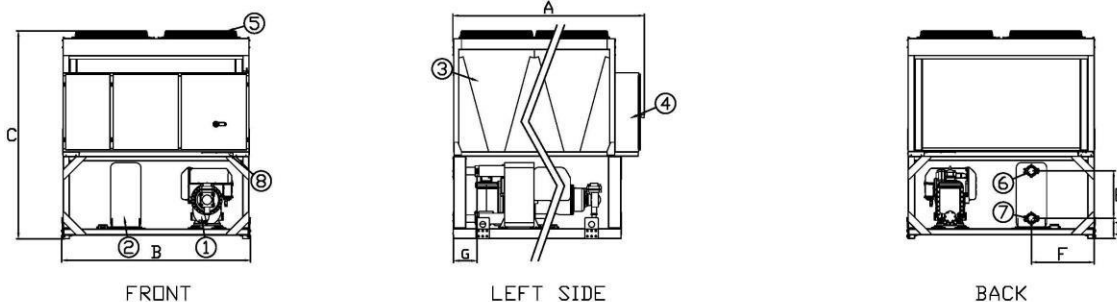

DUAL CIRCUIT -B2

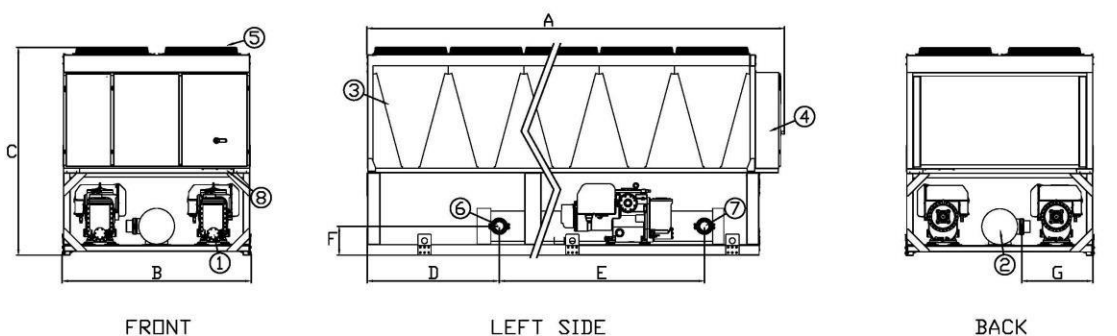

LEGEND

- 1. COMPRESSOR
- 2. EVAPORATOR
- 3. CONDENSER COIL
- 4. ELECTRICAL PANEL
- 5. FAN
- 6. EVAPORATOR WATER INLET
- 7. EVAPORATOR WATER OUTLET
- 8. SLOT FOR POWER AND CONTROL PANEL CONNCTION

note:

the above drawings are not contractually binding. For the design of installation refer to the dedicated dimensional drawing available from the factory on request. The data are subject to change without notice.

MODEL	A	B	C
EWAD190TZ-XL B1	3231	2282	2540
EWAD220TZ-XL B1	3231	2282	2540
EWAD240TZ-XL B1	3231	2282	2540
EWAD290TZ-XL B1	4131	2282	2540
EWAD320TZ-XL B1	4131	2282	2540
EWAD360TZ-XL B2	5030	2282	2540
EWAD420TZ-XL B2	5030	2282	2540
EWAD450TZ-XL B2	5887	2282	2540
EWAD540TZ-XL B2	5887	2282	2540
EWAD570TZ-XL B2	5887	2282	2540
EWAD610TZ-XL B2	6786	2282	2540
EWAD660TZ-XL B2	7684	2282	2540
EWAD680TZ-XL B2	7684	2282	2540
EWAD770TZ-XL B2	7787	2282	2540
EWAD850TZ-XL B2	7787	2282	2540
EWAD910TZ-XL B2	8687	2282	2540
EWADC10TZ-XL B2	9587	2282	2540
EWADC11TZ-XL B2	10488	2282	2540

SINGLE CIRCUIT -B1

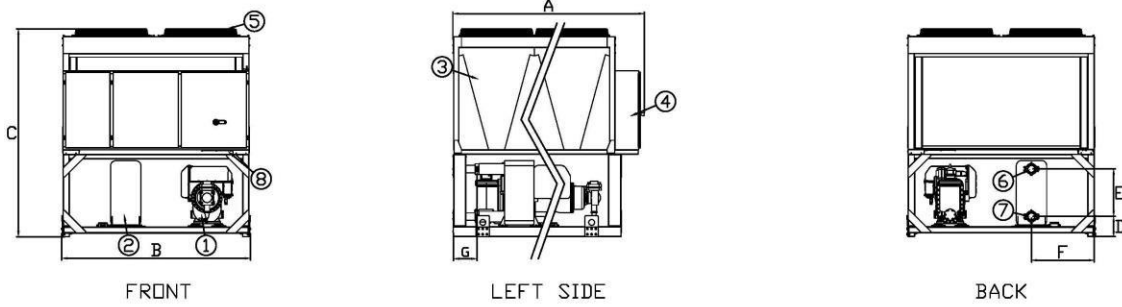

DUAL CIRCUIT -B2

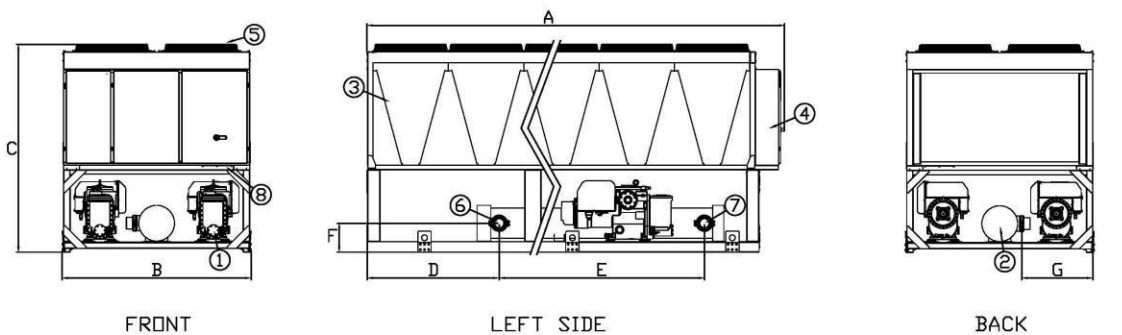

LEGEND

- 1. COMPRESSOR
- 2. EVAPORATOR
- 3. CONDENSER COIL
- 4. ELECTRICAL PANEL
- 5. FAN
- 6. EVAPORATOR WATER INLET
- 7. EVAPORATOR WATER OUTLET
- 8. SLOT FOR POWER AND CONTROL PANEL CONNCTION

note:

the above drawings are not contractually binding. For the design of installation refer to the dedicated dimensional drawing available from the factory on request. The data are subject to change without notice.

MODEL	A	B	C
EWAD190TZ-XR B1	3231	2282	2540
EWAD220TZ-XR B1	3231	2282	2540
EWAD240TZ-XR B1	3231	2282	2540
EWAD290TZ-XR B1	4131	2282	2540
EWAD320TZ-XR B1	4131	2282	2540
EWAD360TZ-XR B2	5030	2282	2540
EWAD420TZ-XR B2	5030	2282	2540
EWAD450TZ-XR B2	5887	2282	2540
EWAD540TZ-XR B2	5887	2282	2540
EWAD570TZ-XR B2	5887	2282	2540
EWAD610TZ-XR B2	6786	2282	2540
EWAD660TZ-XR B2	7684	2282	2540
EWAD680TZ-XR B2	7684	2282	2540
EWAD770TZ-XR B2	7787	2282	2540
EWAD850TZ-XR B2	7787	2282	2540
EWAD910TZ-XR B2	8687	2282	2540
EWADC10TZ-XR B2	9587	2282	2540
EWADC11TZ-XR B2	10488	2282	2540

SINGLE CIRCUIT -B1

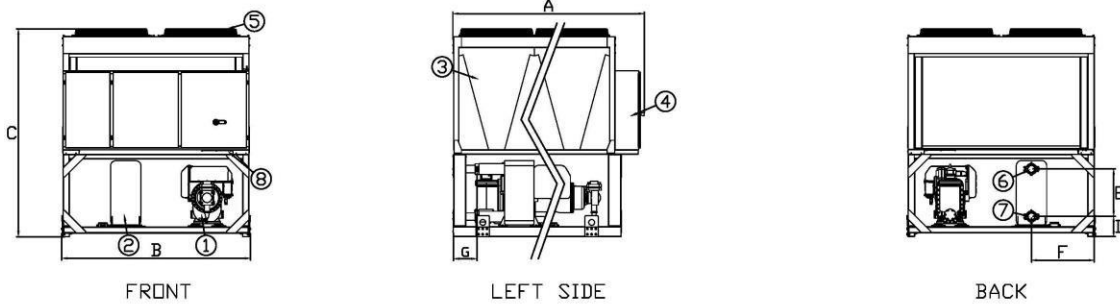

DUAL CIRCUIT -B2

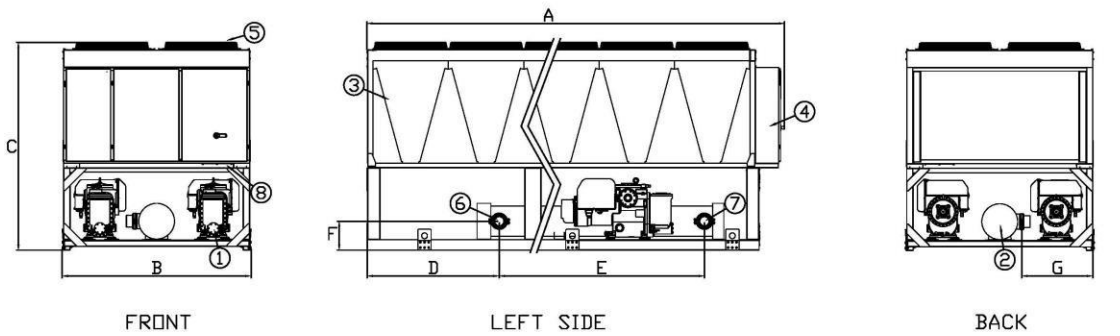

LEGEND

- 1. COMPRESSOR
- 2. EVAPORATOR
- 3. CONDENSER COIL
- 4. ELECTRICAL PANEL
- 5. FAN
- 6. EVAPORATOR WATER INLET
- 7. EVAPORATOR WATER OUTLET
- 8. SLOT FOR POWER AND CONTROL PANEL CONNCTION

note:

the above drwawings are not contractually binding. For the design of installation refer to the dedicated dimensional drawing available from the factory on request. The data ara subject to change without notice.

MODEL	A	B	C
EWAD190TZ-PS B1	4131	2282	2540
EWAD220TZ-PS B1	4131	2282	2540
EWAD240TZ-PS B1	4131	2282	2540
EWAD290TZ-PS B1	4131	2282	2540
EWAD300TZ-PS B1	5030	2282	2540
EWAD350TZ-PS B2	5887	2282	2540
EWAD420TZ-PS B2	6786	2282	2540
EWAD495TZ-PS B2	7684	2282	2540
EWAD550TZ-PS B2	8579	2282	2540
EWAD620TZ-PS B2	9480	2282	2540
EWAD720TZ-PS B2	9587	2282	2540
EWAD820TZ-PS B2	10488	2282	2540
EWAD950TZ-PS B2	11387	2282	2540

SINGLE CIRCUIT -B1

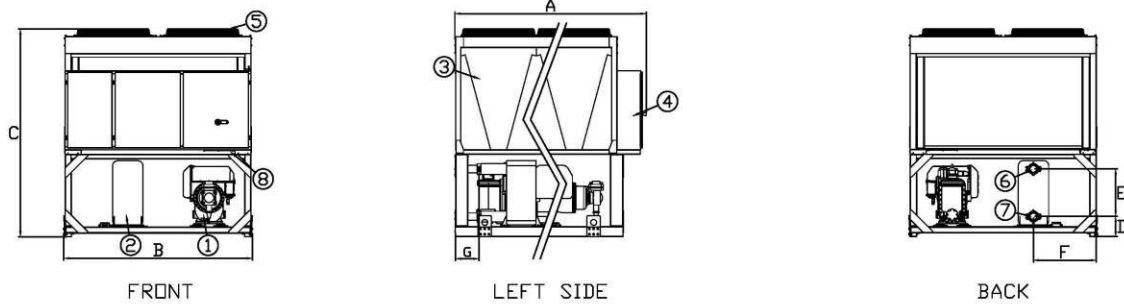

DUAL CIRCUIT -B2

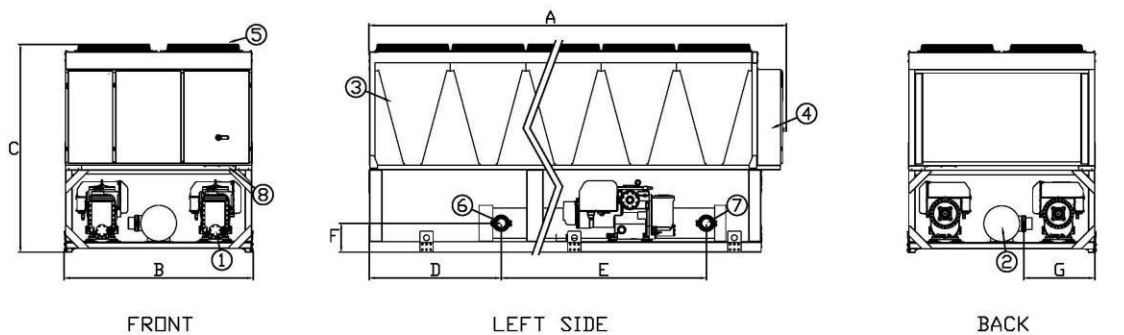

LEGEND

- 1. COMPRESSOR
- 2. EVAPORATOR
- 3. CONDENSER COIL
- 4. ELECTRICAL PANEL
- 5. FAN
- 6. EVAPORATOR WATER INLET
- 7. EVAPORATOR WATER OUTLET
- 8. SLOT FOR POWER AND CONTROL PANEL CONNCTION

note:

the above drawings are not contractually binding. For the design of installation refer to the dedicated dimensional drawing available from the factory on request. The data are subject to change without notice.

MODEL	A	B	C
EWAD190TZ-PL B1	4131	2282	2540
EWAD220TZ-PL B1	4131	2282	2540
EWAD240TZ-PL B1	4131	2282	2540
EWAD290TZ-PL B1	4131	2282	2540
EWAD300TZ-PL B1	5030	2282	2540
EWAD350TZ-PL B2	5887	2282	2540
EWAD420TZ-PL B2	6786	2282	2540
EWAD495TZ-PL B2	7684	2282	2540
EWAD550TZ-PL B2	8579	2282	2540
EWAD620TZ-PL B2	9480	2282	2540
EWAD720TZ-PL B2	9587	2282	2540
EWAD820TZ-PL B2	10488	2282	2540
EWAD950TZ-PL B2	11387	2282	2540

SINGLE CIRCUIT -B1

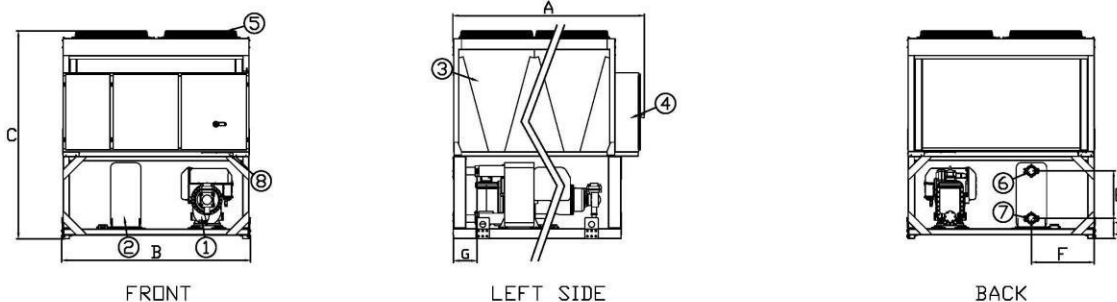

DUAL CIRCUIT -B2

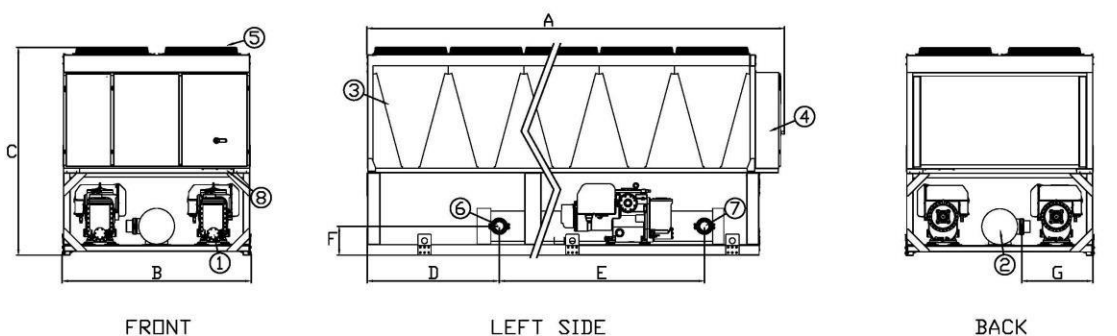

LEGEND

- 1. COMPRESSOR
- 2. EVAPORATOR
- 3. CONDENSER COIL
- 4. ELECTRICAL PANEL
- 5. FAN
- 6. EVAPORATOR WATER INLET
- 7. EVAPORATOR WATER OUTLET
- 8. SLOT FOR POWER AND CONTROL PANEL CONNCTION

note:

the above drwawings are not contractually binding. For the design of installation refer to the dedicated dimensional drawing available from the factory on request. The data ara subject to change without notice.

MODEL	A	B	C
EWAD190TZ-PR B1	4131	2282	2540
EWAD220TZ-PR B1	4131	2282	2540
EWAD240TZ-PR B1	4131	2282	2540
EWAD290TZ-PR B1	4131	2282	2540
EWAD300TZ-PR B1	5030	2282	2540
EWAD350TZ-PR B2	5887	2282	2540
EWAD420TZ-PR B2	6786	2282	2540
EWAD495TZ-PR B2	7684	2282	2540
EWAD550TZ-PR B2	8579	2282	2540
EWAD620TZ-PR B2	9480	2282	2540
EWAD720TZ-PR B2	9587	2282	2540
EWAD820TZ-PR B2	10488	2282	2540
EWAD950TZ-PR B2	11387	2282	2540

Warning Installation and maintenance of the unit must be performed only by qualified personnel who have knowledge with local codes and regulations, and experience with this type of equipment. Must be avoided the unit installation in places that could be considered dangerous for all the maintenance operations.

Handling Care should be taken to avoid rough handling or shock due to dropping the unit. Do not push or pull the unit from anything other than the base frame. Never allow the unit to fall during unloading or moving as this may result in serious damage. To lift the unit, rings are provided in the base frame of the unit. Spreader bar and cables should be arranged to prevent damage to cabinet.

Location The units are produced for outdoor installation on roofs, floors or below ground level on condition that the area is free from obstacles for the passage of the condenser air. The unit should be positioned on solid foundations and perfectly leveled; in the case of installation on roofs or floors, it may be advisable to arrange the use of suitable weight distribution beams. When the units are installed on the ground, a concrete base at least 250 mm wider and longer than the unit's footprint should be laid. Furthermore, this base should withstand the unit weight mentioned in the technical data table.

Space requirements The units are air-cooled, then it is important to respect the minimum distances which guarantee the best ventilation of the condenser coils. Limitations of space reducing the air flow could cause significant reductions in cooling capacity and an increase in electricity consumption.

To determinate unit placement, careful consideration must be given to assure a sufficient air flow across the condenser heat transfer surface. Two conditions must be avoided to achieve the best performance: warm air recirculation and coil starvation. Both these conditions cause an increase of condensing pressures that results in reductions in unit efficiency and capacity. Moreover the unique microprocessor has the ability to calculate the operating environment of the air cooled chiller and the capacity to optimize its performance staying on-line during abnormal conditions.

Each side of the unit must be accessible after installation for periodic service. The following pictures shows you minimum recommended clearance requirements.

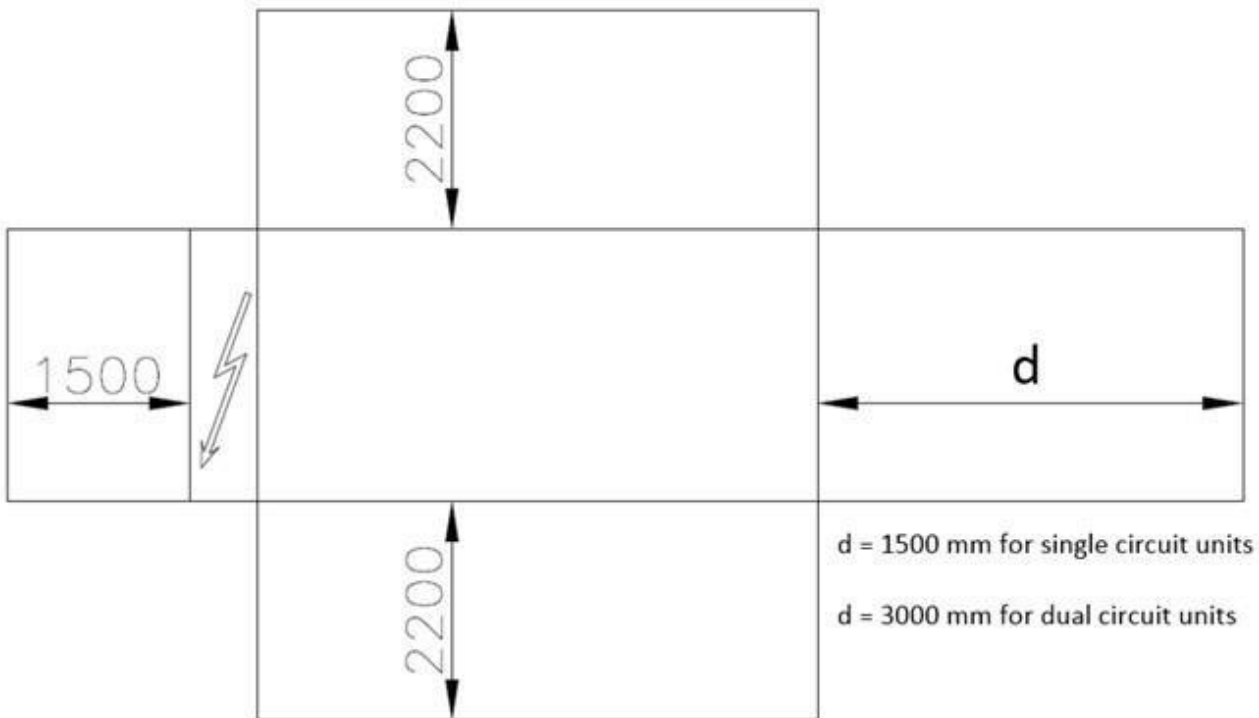

For single chiller installation in proximity of a wall the following indications are recommended:

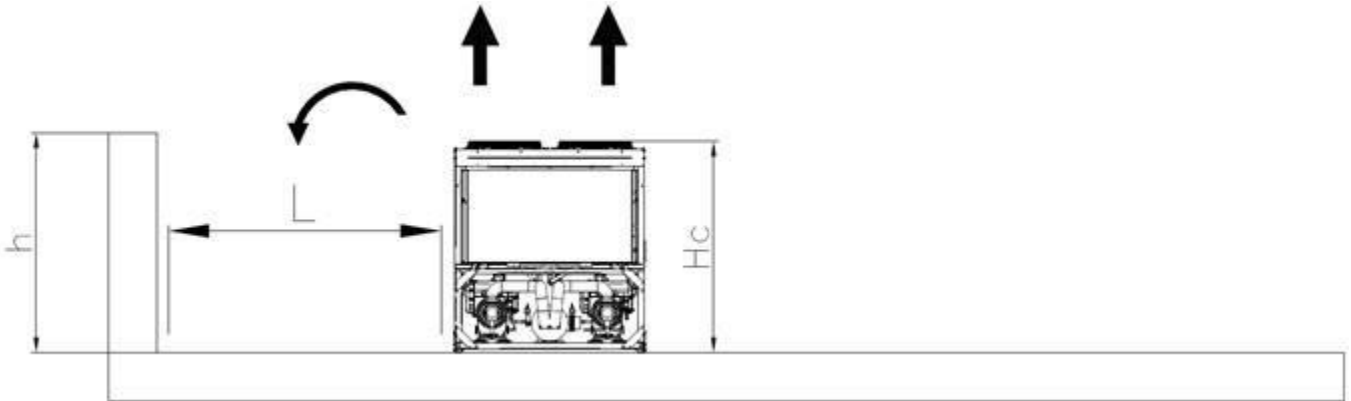

- if $h < H_c \rightarrow L$ must at least 3 m
- if $h \geq H_c$ or $L < 3$ m contact local Daikin representative to evaluate possible arrangements

In case of two chillers installed side by side in free filed, the minimum distance recommended between the chillers is indicated in the below picture

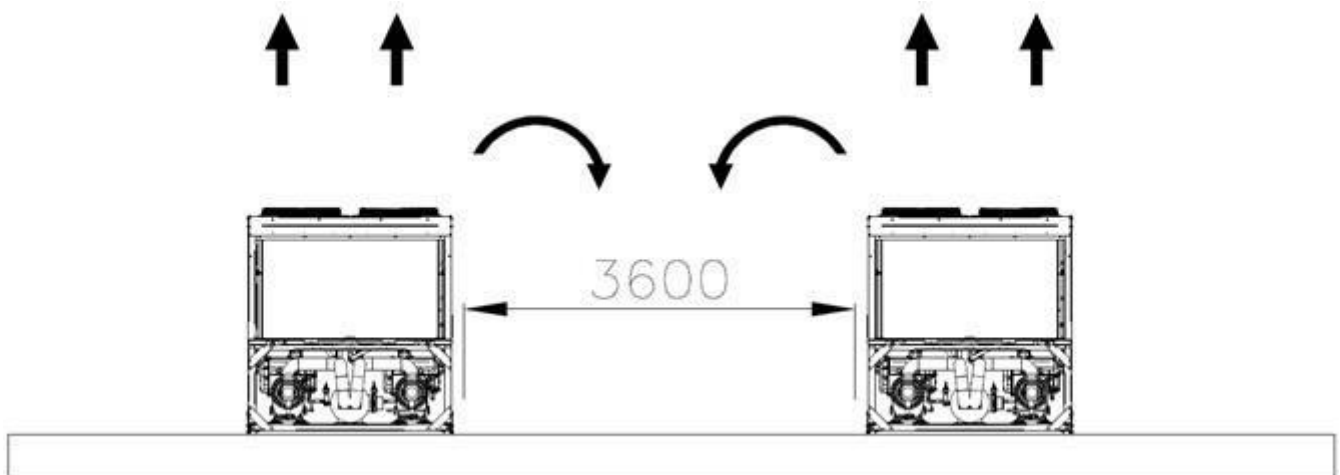

In case of two chillers installed in a compound contact local Daikin representative to evaluate possible arrangements.

For multiple chiller installation it is recommended to install the chillers in a single row as shown in the below picture

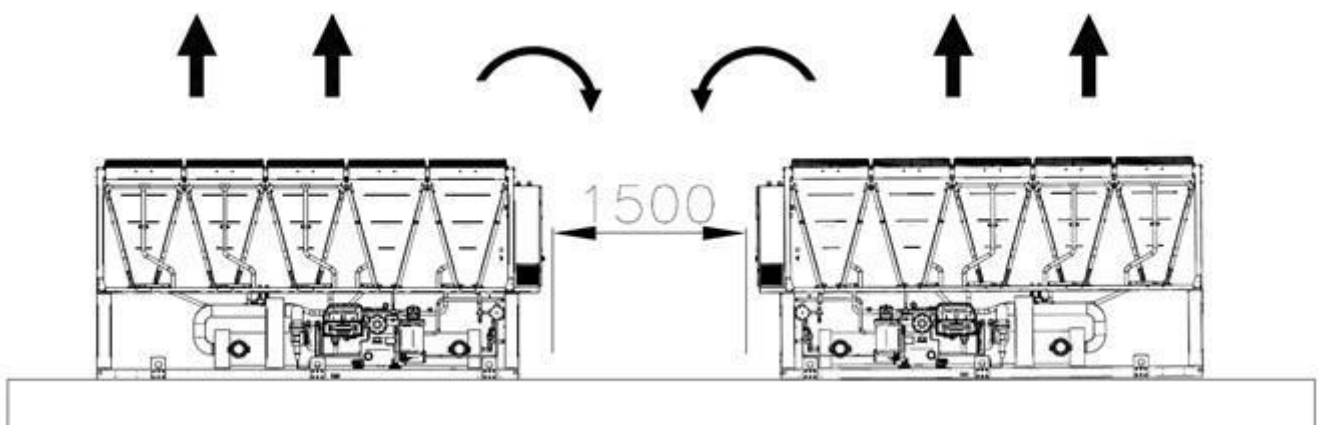

For additional information refer to the Installation Manual.

If the site does not allow this kind of installation contact Daikin representative to evaluate possible arrangements.

General The chiller will be designed and manufactured in accordance with the following European directives:

- Construction of pressure vessel 2014/68/EU
- Machinery Directive 2006/42/EC
- Low Voltage 2014/35/EU
- Electromagnetic Compatibility 2014/30/EU
- Electrical & Safety codes EN 60204-1 / EN 60335-2-40
- Manufacturing Quality Standards UNI – UNI EN ISO 1400

To avoid any losses, the unit will be tested at full load in the factory (at the nominal working conditions and water temperatures). The chiller will be delivered to the job site completely assembled and charged with refrigerant and oil.

The installation of the chiller must comply with the manufacturer's instructions for rigging and handling equipment.

The unit will be able to start up and operate (as standard) at full load with:

- outside air temperature from..... °C to..... °C
- evaporator leaving fluid temperature between..... °C and..... °C

Refrigerant HFC 134a

Performance Chiller shall supply the following performances:

- Number of chiller(s):..... unit(s)
- Cooling capacity for single chiller:..... kW
- Power input for single chiller in cooling mode:..... kW
- Heat exchanger entering water temperature in cooling mode:..... °C
- Heat exchanger leaving water temperature in cooling mode:..... °C
- Heat exchanger water flow:..... l/s
- Nominal outside working ambient temperature in cooling mode:..... °C
- Minimum full load efficiency (EER): (kW/kW)
- Minimum part load efficiency (ESEER): (kW/kW)

Operating voltage range should be 400V ±10%, 3ph, 50Hz (or 380V ±10%, 3ph, 60Hz), voltage unbalance maximum 3%, without neutral conductor and shall only have one power connection point.

Unit description Chiller shall include one or two independent refrigerant circuits, semi-hermetic type rotary single screw compressors, refrigerant cooled inverter drive for each compressor, electronic expansion device (EEXV), direct expansion 'shell & tube' or PHE evaporator, air-cooled condenser section made with aluminum Microchannel technology, R-134a refrigerant, lubrication system, motor starting components, discharge line shut-off valve, suction line shut-off valve, control system and all components necessary for a safe and stable unit operation.

The chiller will be factory assembled on a robust base frame made of galvanized steel, protected by an epoxy paint.

Sound level and vibrations Sound power level shall not exceeddB(A). The sound power levels must be rated in accordance to ISO 9614 (other types of rating cannot be used). Vibration on the base frame should not exceed 2 mm/s.

Dimensions Unit dimensions shall not exceed following indications:

- Unit length..... mm
- Unit width..... mm
- Unit height..... mm

Compressors

- Semi-hermetic, single-screw type with one main helical rotor meshing with the gaterotor. The gaterotor will be constructed of a carbon impregnated engineered composite material. The gaterotor supports will be constructed of cast iron.
- Each compressor shall be fitted with inverter drive for variable capacity control. Inverter shall be integrated within the compressor casing and it shall be cooled by liquid refrigerant.
- Each compressor shall be provided with Variable Volume Ratio (VVR) technology. The system shall modify the volumetric compression ratio according to the operating conditions in order to enhance the efficiency.
- Each compressor shall be provided with DC motors (for GOLD and PLATINUM efficiency series)
- The oil injection shall be used in order to get high EER (Energy Efficiency Ratio) also at high condensing pressure and low sound pressure levels in each load condition.
- Refrigerant system differential pressure shall provide oil flow through service replaceable, 0.5 micron, full flow, cartridge type oil filter internal to compressor.
- Refrigerant system differential pressure shall provide oil injection on all moving compressor parts to correctly lubricate them. Electrical oil pump lubricating system is not acceptable.
- The compressor's oil cooling must be realized, when necessary, by refrigerant liquid injection. External

dedicated heat exchanger and additional piping to carry the oil from the compressor to heat exchanger and viceversa will be not accepted.

- The compressor shall be provided with an integrated, high efficiency, cyclonic type oil separator and with built-in oil filter, cartridge type.
- The compressor shall be direct electrical driven, without gear transmission between the screw and the electrical motor.
- The compressor casing shall be provided with ports to realize economized refrigerant cycles.
- The economizer cycle shall be provided with electronic expansion valve
- The unit shall be provided with two thermal protection realized by a thermistor for high temperature protection: one temperature sensor to protect electrical motor and another sensor to protect unit and lubricating oil from high discharge gas temperature.
- The compressor shall be equipped with an electric oil-crankcase heater.
- Compressor shall be fully field serviceable. Compressor that must be removed and returned to the factory for service shall be unacceptable.

Cooling capacity control system

The chiller will have a microprocessor for the control of the compressor capacity through inverter in order to continuously modulate the compressor's rotational speed.

- The unit capacity control shall be infinitely modulating between 100% and the minimum.
- The chiller shall be capable of stable operation to minimum capacity without hot gas bypass.
- The system shall control the unit based on the leaving evaporator water temperature that shall be controlled by PID (Proportional Integral Derivative) logic.
 - Unit control logic shall to manage frequency level of the compressor electric motor to exactly match plant load request in order to keep constant the set point for delivered chilled or hot water temperature.
 - The microprocessor unit control shall detect conditions that approach protective limits and take self corrective action prior to an alarm occurring. The system shall automatically reduce the chiller capacity when any of the following parameters are outside their normal operating range:
 - High condenser pressure
 - Low evaporating refrigerant temperature
- Unit-mounted Compressor's Inverter and Electrical Requirement
Customer electrical connection for compressor motor power shall be limited to the main power lead to the single point power connection located into electrical panel.
- The Inverter shall be refrigerant cooled. Water cooled or air cooled inverter cooling are not acceptable.
 - Base motor frequency shall permit motor to be utilized at nameplate voltage. Adjustable frequency range, monitored by unit's microprocessor control, shall permit a stable unit capacity control down to minimum capacity without hot-gas bypass.
 - Unit displacement power factor shall be not less than 0.95 on entire unit capacity range, from 100% down to minimum capacity.

Evaporator

(Single circuit unit)

The units shall be equipped with a direct expansion plate to plate type evaporator.

- The evaporator will be made of stainless steel brazed plates and shall be linked with an electrical heater controlled by a thermostat and shall be insulated with flexible, closed cell polyurethane insulation material.
- The evaporator will have 1 refrigerant circuit for each compressor.
- The water connections shall be VICTAULIC type connections as standard to ensure quick mechanical disconnection between the unit and the hydronic network.
- The evaporator will be manufactured in accordance to PED approval.
- Flow switch on evaporator available as option (shipped loose).
- Water filter will be standard.

(Dual Circuit units)

The units shall be equipped with a direct expansion shell & tube evaporator with copper tubes rolled into steel tube sheets. The evaporator shall be single-pass on both the refrigerant and water sides for pure counter-flow heat exchange and low refrigerant pressure drops.

- The external shell shall be linked with an electrical heater to prevent freezing down to -28°C ambient temperature, controlled by a thermostat and shall be insulated with flexible, closed cell polyurethane insulation material (20-mm thick).
- The evaporator will have 2 circuits, one for each compressor and shall be single refrigerant pass.
- The water connections shall be VICTAULIC type connections as standard to ensure quick mechanical disconnection between the unit and the hydronic network.
- The evaporator will be manufactured in accordance to PED approval.
- Flow switch on evaporator available as option (shipped loose).
- Water filter needs to be provided on the plant.

Condenser coil The condenser is made entirely of aluminum with flat tubes containing small channels. Full - depth louvered aluminum fins are inserted between the tubes maximizing the heat exchange. The

Microchannel

technology ensures the highest performance with the minimum surface for the exchanger. The quantity of

refrigerant is also reduced compared to Cu/Al condenser. Special treatments ensure resistance to the corrosion by atmospheric agents extending the life time (available on request).

Condenser fans The condenser fans used in conjunction with the condenser coils, shall be propeller type or Brushless with glass reinforced resin blades for higher efficiencies and lower sound. Each fan shall be protected by a fan guard.

- The air discharge shall be vertical and each fan must be coupled to the electrical motor, supplied as standard to IP54 and capable to work to ambient temperatures of - 20°C to + 65°C.
- The condenser fans shall have as a standard a thermally protection by internal thermal motor protection and protected by circuit breaker installed inside the electrical panel as a standard.

Refrigerant circuit The unit shall have one or two independent refrigerant circuits and one variable electrical frequency driver per compressor (Inverter).

- The circuit shall include as standard: electronic expansion device piloted by unit's microprocessor control, compressor suction and discharge shut-off valves, liquid line shut-off valve, economizer circuit with electronic expansion valve, sight glass with moisture indicator, replaceable filter drier, charging valves, high pressure switch, high and low pressure transducers, oil pressure transducer and insulated suction line. Condensation control The units will be provided with an automatic control for condensing pressure which ensures the working at low external temperatures down to - °C, to maintain condensing pressure.
- The compressor automatically unloads when abnormal high condensing pressure is detected. This to prevent the shutdown of the refrigerant circuit (shutdown of the unit) due to a high-pressure fault.

Reduced Sound unit configurations (on request) The compressor shall be connected with unit's metal base frame by rubber anti vibration supports to prevent the transmission of vibrations to all metal unit structure, in order to limit the unit noise emissions. The chiller shall be provided with an acoustical compressor enclosure (according to the version). This enclosure shall be realized with a light, corrosion resisting aluminum structure and metal panels. The compressor sound-proof enclosure shall be internally fitted with flexible, multi-layer, high density materials.

Hydronic kit options (on request) The hydronic module shall be integrated in the chiller chassis without increasing its dimensions and includes the following elements: centrifugal pump with motor protected by a circuit breaker installed in control panel, water filling system with pressure gauge, safety valve, drain valve.

- The hydronic module shall be assembled and wired to the control panel.
- The water piping shall be protected against corrosion and freezing and insulated to prevent condensation.
- A choice of two pump types shall be available:
 - in-line single pump
 - in-line twin pumps.

The unit should be able to operate in Primary only system with two-ways valve on terminals with Variable Primary Flow control strategy (available as option on request).

Master/Slave the unit shall be able to operate in Master / Slave mode in order to be connected with other similar unit (up to 4). The master unit shall manage the slaves units connected in series on the hydraulic plant with the aim of optimize the running hours of each compressor and to balance running hours and the load between the units.

Electrical control panel Power and control shall be located in the main panel that will be manufactured to ensure protection against all weather conditions.

- The electrical panel shall be IP54 and (when opening the doors) internally protected against possible accidental contact with live parts.
- The main panel shall be fitted with a main switch interlocked door that shuts off power supply when opening.
- The power section will include compressors and fans protection devices, fans starters and control circuit power supply.

Controller The controller will be installed as standard and it will be used to modify unit set-points and check control parameters.

- A built-in display will shows chiller operating status plus temperatures and pressures of water, refrigerant and air, programmable values, set-points.
- A sophisticated software with predictive logic, will select the most energy efficient combination of compressors, EEXV and condenser fans to keep stable operating conditions to maximize chiller energy efficiency and reliability.
- The controller will be able to protect critical components based on external signals from its system (such as motor temperatures, refrigerant gas and oil pressures, correct phase sequence, pressure switches and evaporator). The input coming from the high pressure switch cuts all digital output from the controller in less than 50ms, this will be an additional security for the equipment.
- Fast program cycle (200ms) for a precise monitoring of the system.
- Floating point calculations supported for increased accuracy in P/T conversions.

Controller main features

Controller shall be guarantee following minimum functions:

- Management of the compressor stepless capacity and fans modulation.

- Chiller enabled to work in partial failure condition.
- Full routine operation at condition of:
 - high ambient temperature value
 - high thermal load
 - high evaporator entering water temperature (start-up)
- Display of evaporator entering/leaving water temperature.
- Display of Outdoor Ambient Temperature.
- Display of condensing-evaporating temperature and pressure, suction and discharge superheat for each circuit.
- Leaving water evaporator temperature regulation.
- Compressor and evaporator pumps hours counter.
- Display of Status Safety Devices.
- Number of starts and compressor working hours.
- Optimized management of compressor load.
- Fan management according to condensing pressure.
- Re-start in case of power failure (automatic / manual).
- Soft Load (optimized management of the compressor load during the start-up).
- Start at high evaporator water temperature.
- Return Reset (Set Point Reset based on return water temperature).
- OAT (Outside Ambient temperature) Reset.
- Set point Reset (optional).
- Application and system upgrade with commercial SD cards.
- Ethernet port for remote or local servicing using standard web browsers.
- Master / Slave (provided as standard)
- Variable primary Flow (available as option)
- Two different sets of default parameters could be stored for easy restore. High Level Communications Interface (on request) The chiller shall be able to communicate to BMS (Building Management System) based on the most common protocols as:
 - ModbusRTU
 - LonWorks, now also based on the international 8040 Standard Chiller Profile and LonMark Technology
 - BacNet BTP certified over IP

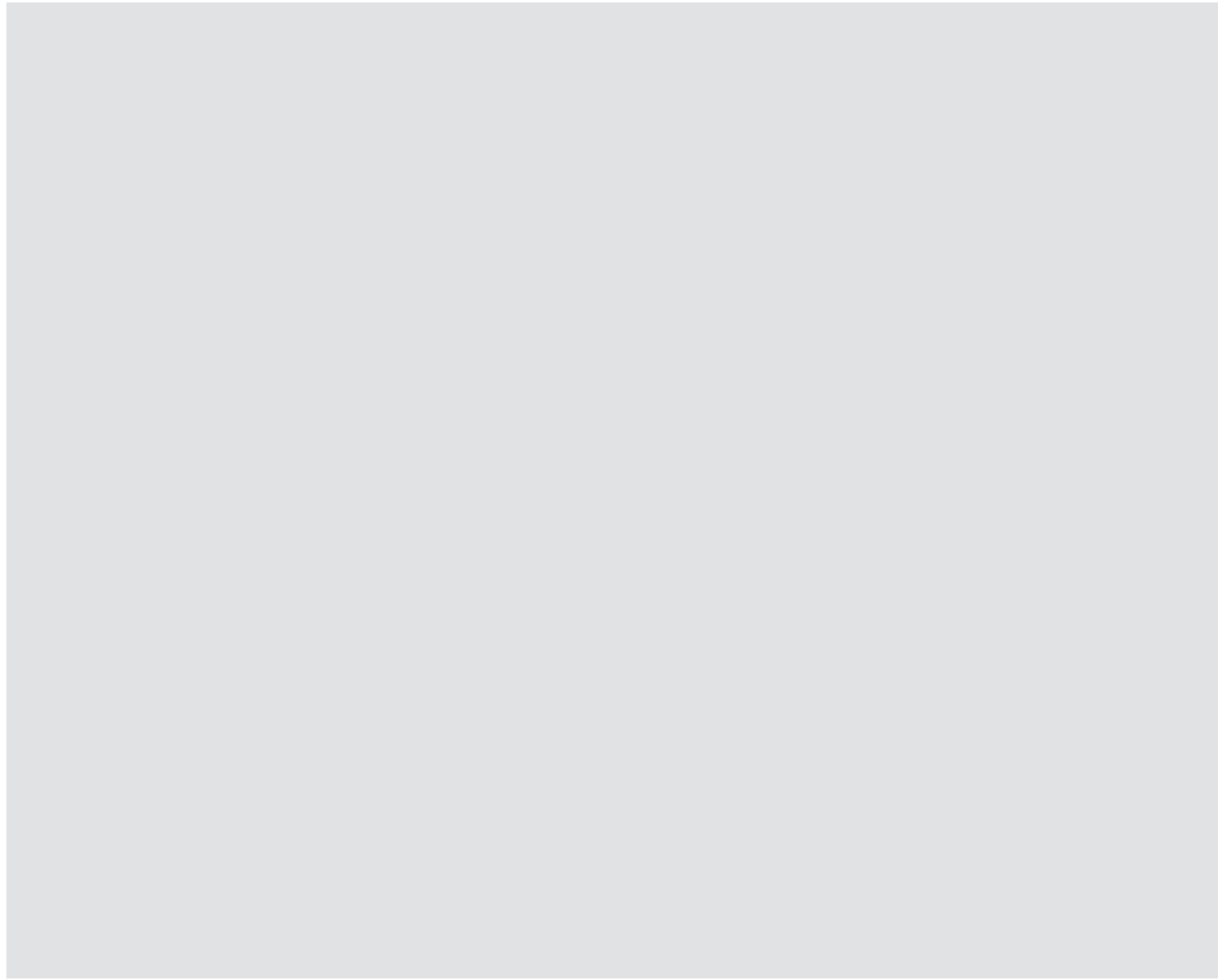

For more information email info@daikinapplied.uk or visit www.daikinapplied.uk

For all Daikin Applied UK,
Daikin Applied Service &
Spares enquiries call us on:
0345 565 2700



Daikin Europe N.V. participates in the Eurovent Certified Performance programme for Liquid Chilling Packages and Hydronic Heat Pumps, Fan Coil Units and Variable Refrigerant Flow systems. Check ongoing validity of certificate:
www.eurovent-certification.com

The present publication is drawn up by way of information only and does not constitute an offer binding upon Daikin Europe N.V. Daikin Europe N.V. has compiled the content of this publication to the best of its knowledge. No express or implied warranty is given for the completeness, accuracy, reliability or fitness for particular purpose of its content and the products and services presented therein. Specifications are subject to change without prior notice. Daikin Europe N.V. explicitly rejects any liability for any direct or indirect damage, in the broadest sense, arising from or related to the use and/or interpretation of this publication. All content is copyrighted by Daikin Europe N.V.

