

Installation, operation,  
and maintenance manual

# Modular Rotary Modular Plate

D-EIMAH00211-19\_02EN



› Modular P and R

**Translation of the original instructions**

REV	02
DATE	April 2022
SUPERSEDES	D-EIMAH00211-19_01EN

Daikin air handling units guarantee high quality indoor air at low energy costs. Fully customisable systems or pre-configured standard modular units are available.

Armed with an extremely flexible development, Daikin air handling units can satisfy all types of technical requirements.

Daikin systems guarantee respect for the environment since they are based on high levels of energy efficiency. Reduced ecological impact and low energy consumption make Daikin air handling units ideal for any type of market.

# Contents

<b>Important warnings</b>	<b>4</b>
Purpose of the manual	4
Intended use of the machine	4
Safety regulations	5
Residual risks	7
Safety devices	8
<b>Machine characteristics</b>	<b>9</b>
Environmental conditions	9
Environmental contamination	9
Controller limit operating conditions	10
Range specifications	10
Attachments	11
Summary of machine operation	12
Adhesives on the machine	14
Machine description (Modular Plate)	16
Machine description (Modular Rotary)	18
<b>Receipt of the cartons</b>	<b>21</b>
Read the packaging symbols	21
<b>Transport</b>	<b>22</b>
Lifting using hooks	22
Lifting using a pallet truck	24
Lifting non-palletized equipment	24
<b>Unpacking and verification of integrity</b>	<b>25</b>
After unpacking	25
Reading the serial number plate	26
Storage waiting for installation	27
<b>Installation</b>	<b>29</b>
Installation procedure	30
Rotary heat exchanger alignment adjustment	43
<b>Commissioning</b>	<b>62</b>
Use of the machine	63
<b>Maintenance</b>	<b>64</b>
Safety precautions for maintenance	64
Ordinary maintenance	65
Extraordinary maintenance	69
Diagnostics	71
Troubleshooting table	72
Repair log	73
<b>Use</b>	<b>74</b>

# 1 Important warnings



The pictogram shows a situation of immediate danger or a dangerous situation that might cause injuries or death.



The pictogram shows that it is necessary to adopt suitable behavior to avoid jeopardizing staff safety and cause damages to the equipment.



The pictogram shows particularly important technical information that should be taken into consideration by the people installing or using the equipment.

## Purpose of the manual

The purpose of this **manual** is to guide the installer and qualified operator in the installation, maintenance, and proper and safe use of the equipment. For this reason, **it is mandatory for all personnel involved in installation, maintenance, and supervision of the machine to read this manual.**

Contact the manufacturer if any points are unclear or difficult to understand.

This manual contains information regarding:

- Technical specifications of the machine.
- Instructions for transport, handling, installation and assembly.
- Use.
- Information for instructing personnel authorized for its use.
- Maintenance activities.

All information refers in general to any unit of the Modular R and Modular P ranges. All units are shipped accompanied by:

- electrical diagram,
- manual for all accessories,
- section coupling manual,
- operating manual,
- installation manual,
- declaration of conformity,
- electrical panel CE certification,
- electrical panel test report.

## Intended use of the machine

This appliance has the function of treating the air intended to condition civil and industrial environments. Any other use is not in accordance with the intended use and therefore dangerous.

These ranges of units are designed for use in NON-explosive environments. For installation in potentially explosive environments, the manufacturer can design and manufacture suitable machines (anti-explosion) that will be identified by the  mark.

If the machine is used in critical situations, by type of system or environmental context, the customer must identify and adopt the technical and operational measures to avoid damage of any kind.

# Safety regulations

## Skills required for the installation of the machine



Installers must perform operations according to their professional qualifications: all activities not within one's expertise (i.e. electrical connections) must be carried out by specialized and qualified staff so as not to endanger one's safety and the safety of the other operators interacting with the machine.



**Transport and equipment handling operator:** authorized person with recognized expertise in using transport and lifting equipment.



**Technical installer:** expert technician, sent or authorized by the manufacturer or its representative, with adequate skills and training to install the machine.

**Assistant:** technician subject to care obligations while lifting and assembling the equipment. He must be suitably trained and informed about the operations to perform and the safety plans of the site/installation location.

In this manual, the technician competent to carry out each operation is specified.

## Skills required for the use and maintenance of the machine



**Generic operator:** AUTHORISED to run the machine using commands placed on the keypad of the electrical control panel. Performs only machine control operations, power on/off.

**Maintenance mechanic (qualified):** AUTHORISED to carry out maintenance, adjustments, replacement, and repair of mechanical parts. It must be a person competent in mechanical systems, therefore able to perform mechanical maintenance in a satisfactory and safe manner, must possess theoretical preparation and manual experience. NOT AUTHORISED to work on electrical systems.

**Manufacturer's technician (qualified):** AUTHORISED to perform complicated operations in every situation. Operates in accordance with the user.



**Maintenance electrician (qualified):** AUTHORISED to perform service of an electric nature, adjustments, maintenance, and electrical repairs. AUTHORISED to operate in the presence of an active electrical connection inside the control panels and junction boxes. It must be a person competent in electronics and electrical engineering, therefore able to work on electrical systems satisfactorily and safely, must possess theoretical knowledge and proven experience. NOT AUTHORISED to work on mechanical systems.



Installers, users, and maintenance staff for the machine must also:

- Be responsible and experienced adults without physical impairments, in perfect psychological and physical condition.
- Master the machine's operating cycle, therefore participate in theoretical/practical training alongside an expert machine operator, or alongside a technician of the manufacturer.

In this manual, the technician competent to carry out each operation is specified.



Read this manual carefully before machine installation and maintenance and keep it for any further future consultation by the various operators. Do not remove, tear out or rewrite any part of this manual.



All installation, assembly, electrical connections to the mains and ordinary/extraordinary maintenance must be performed **only by qualified personnel authorized by the Retailer or Manufacturer** after turning off the unit electrically and using personal protective equipment (i.e., gloves, protective goggles, etc.), in compliance with the regulations in force in the country the equipment is to be used in and the laws regarding the systems and safety in the workplace.



Installation, use or maintenance other than those specified in the manual may cause damage, injury, or death, invalidate the warranty and relieve the Manufacturer of any liability.



Use protective clothing and suitable equipment while handling or installing the equipment, to prevent accidents and safeguard your own and other people's safety. Individuals not assigned to installation or maintenance are NOT allowed to stand or pass through the work area while the machine is assembled.



**Disconnect the equipment from the mains before installing or maintaining it.**



Before installing the equipment, check that the systems comply with the legal provisions in force in the country of use and meet the specifications on the serial number plate.



It is the responsibility of the user/installer to check the static and dynamic stability relative to the installation and to arrange environments so that **people who are not competent or authorized DO NOT have access to the machine or to its commands.**



It is the responsibility of the user/installer to make sure that **weather conditions** do not affect the safety of persons and property during installation, use and maintenance.



Make sure the air intake is not located near any exhausts, flue-gases, or other contaminating elements.



Do NOT install the equipment in places exposed to strong winds, salt air, open flames, or temperatures exceeding 46°C (115°F).



After installation is complete, instruct the user on the correct use of the machine.

If the equipment does not work or functional or structural alterations are noted, disconnect it from the mains and contact a service centre authorized by the Manufacturer or Retailer, without attempting to repair it on your own. For any replacements request the use of original spare parts. Unauthorized actions, tampering or modifications that do not follow the information provided in this manual can cause damage, injuries or fatal accidents and void the warranty.

The serial number plate on the unit provides important technical information, essential in case of machine maintenance or repairs. We recommend that you do not remove, damage, or modify it. To ensure correct and safe conditions of use, it is recommended to have the unit maintained and checked at least annually by a service centre authorized by the manufacturer or dealer.

**Failure to follow these instructions may cause damage and injuries, even fatal, voids the warranty and relieves the Manufacturer of any liability.**

# Residual risks

Despite having implemented and adopted all the safety measures indicated by applicable regulations, some residual risks remain. In particular, in some operations of replacement, adjustment and tooling maximum attention is always required in order to work in the best possible conditions.

## List of operations with residual risks

Risks for qualified personnel (electrician and mechanic)

- Handling - during unloading and handling it is necessary to pay attention to all the steps listed in this manual regarding the points of reference
- Installation - during installation it is necessary to pay attention to all the steps listed in this manual regarding the points of reference  
The installer must ensure the static and dynamic stability of the machine's site of installation.
- Maintenance - during maintenance it is necessary to pay attention to all the steps listed in this manual, and to high temperatures that may be present in the heat transfer fluid lines to/from the unit.
- Cleaning - the machine must be cleaned only when it is switched off, by turning off the switch installed by the electrician and the switch located on the unit itself. The key for interrupting the power supply must be kept by the operator until the end of the cleaning operations. Internal cleaning of the machine must be carried out using the protections required by current regulations. While the inside of the machine does not contain hazards, it is necessary to pay the utmost attention so that accidents do not occur during cleaning. The heat exchange coils that have a potentially sharp finned pack must be cleaned using protective glasses and gloves suitable for handling metals.

During adjustment, maintenance, and cleaning there are residual risks of variable entity. Being operations that must be performed with guards disabled, it is necessary to pay particular attention to avoid damage to persons and things.



Always pay close attention when performing the operations specified above.

Remember that these operations must always be performed by authorized personnel.

All work must be completed in accordance with the legal provisions relating to work safety.

Remember that the unit in question is an integral part of a larger system that includes other components, depending on the final characteristics of realization and the mode of use. Therefore, in the end it is the responsibility of the user and assembler to assess the residual risks and their respective preventive measures.



For more information about the possible risks, please refer to the RAD (Risk Assessment Document) available from the manufacturer.

# Safety devices



The machine is equipped with safety devices to prevent risks of damage to persons and for proper operation. Always pay attention to the symbols and safety devices on the machine. It should **only** operate with the safety devices engaged and with fixed or movable guards installed correctly and in the proper position.



If during installation, use or maintenance the safety devices have been temporarily removed or disabled, the machine can be operated **exclusively** by the qualified technician who made this change. It is **mandatory** to prevent other people's access to the machine. When finished, restore the devices to their proper status as soon as possible.

**Key lock (standard):** the doors to access the machine's fan area have a key lock on the handle, to avoid their opening by unauthorized persons.

**Micro Switch (optional):** the doors to access the machine's fan areas can be equipped with a Micro Switch to interrupt the power supply. They are of the "magnetic proximity sensor" type with polarized magnet, which cannot be excluded by means of magnetized instruments, guaranteeing correct operation even in conditions of permanent humidity.

**Protective guard (optional):** in the transmission area the motor-cooling unit is equipped with a suitably shaped protective guard, mechanically and jointly attached.

**Safety handles (standard):** double-click handle system for the access doors to the ventilating area of the machine to prevent accidental opening during operation.



# 2 Machine characteristics

## Environmental conditions



The machine was designed to operate in technical spaces or outdoors. It **CANNOT** operate in environments with **explosive material**, high concentration of **dust** and in environments with **high temperatures (range from -25 ÷ 46°C - maximum altitude: 2500 m above sea level)**, unless specific production requests were made.



These machines are used to resolve thermohydrometric and air purity problems in both civil and industrial environments.



Thanks to its modularity, each machine can adapt to different needs in terms of air handling:

- civil
- airports
- banking
- commercial
- hotel
- museums, theatres, cinemas and auditoriums
- television and recording studios
- libraries
- data processing centres



The optimized choice of every detail, the search for maximum efficiency in each component, the adoption of specific materials and constructive solutions transform environment friendliness and energy savings into valid and advanced technological solutions.

## Environmental contamination

Depending on the installation operating environment, specific regulations must be followed, and all the necessary precautions must be taken to avoid environmental issues (a system that operates in a hospital or chemical environment can have problems different from those in other sectors, even from the point of view of disposal of consumable parts, filters, etc.).

It is mandatory for the buyer to inform and train workers regarding proper procedures.

# Controller limit operating conditions

## Operation (IEC 721-3-3):

- Temperature  $-40 \div +70$  °C
- LCD  $-20 \div +60$  °C
- Humidity <90% relative humidity (without condensation)
- Min. air pressure 700 hPa, corresponding to a maximum of 3,000 m above sea level
- Transport (IEC 721-3-2) and storage:
- Temperature  $-40 \div +70$  °C
- Humidity <95% relative humidity (without condensation)
- Min. air pressure 260 hPa, corresponding to a maximum of 10,000 m above sea level

## Range specifications

The MACHINE is designed and built for air treatment and can have different configurations depending on the type of treatment requested by the customer. In this sense, the MACHINE consists of several sections, each of them with a specific function, which may or may not be present according to the type of treatment requested.

The supporting structure consists of profiles made by aluminium alloy extrusion. The fixing screws are concealed in the profile itself to have smooth surfaces on the inside. The panels of the structure consist of two zinc-plated box press-folded sheets injected with polyurethane. Alternatively, as an insulator, mineral wool can be used. Where necessary, along the panels, doors with locked handles and/or portholes are installed to inspect the inside of the machine.

## Construction specifications:

- Profile type: anodized aluminium with thermal break
- Insulation panels: polyurethane or mineral wool

## Base module

- Condensing or absorbing rotary recuperator, or with counterflow plates,
- Single suction EC-type centrifugal fans with integrated electronics (2 in parallel for each fan section for size 09-10) or plug fans,
- Pocket filters,
- Compact prefilters,
- Aluminium dampers,
- Condensate drain tank downstream of the recuperator (only for Modular-P model).

## Additional modules

In addition to the Basic Module, depending on the customer's needs, it is also possible to add optional components:

- Mixing Module, used to vary the mixture of the supplied air,
- Attenuator in Exhaust Air,
- Attenuator in Fresh Air,
- Electric heating battery (preheating or post-heating),
- Additional rigid pocket filter,
- Hot water battery,
- Cold water battery,
- As an alternative to water batteries, direct expansion batteries can be used for both heating and cooling.

## Available modules:

- Battery module,
- Filter module,
- Pre- and post-heating module,
- Flow separating module with side dampers,
- Mixing module,
- Single or combined silencing module,
- Combined silencing module with damper,
- Electric pre- or post-heating module,
- Humidification module.

## Attachments

To complete this manual, together with the delivery of the machine, the following documents are issued:

- Electrical diagrams,
- Operating manual,
- Declaration of conformity,
- Electrical panel certification.

# Summary of machine operation

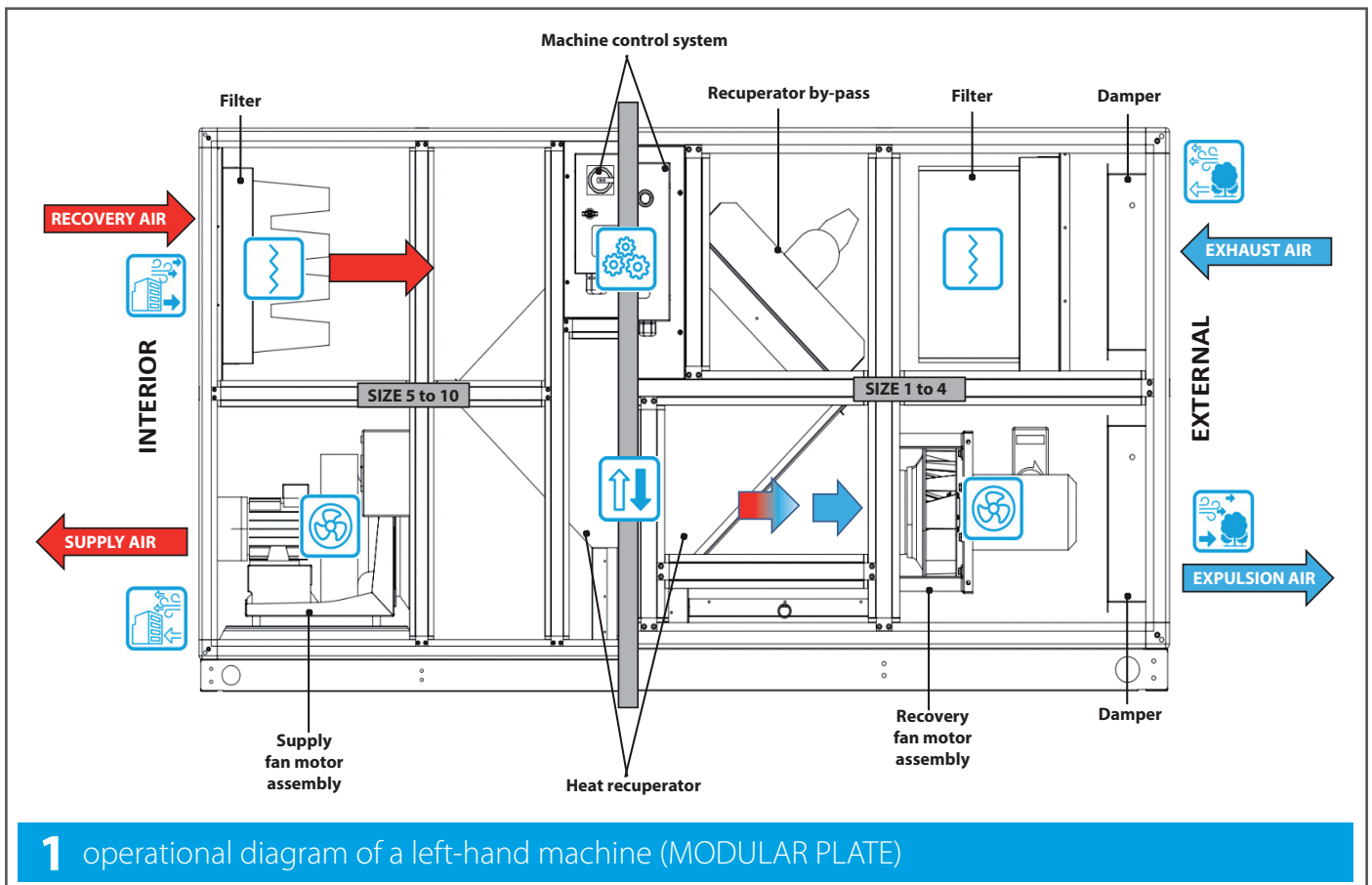
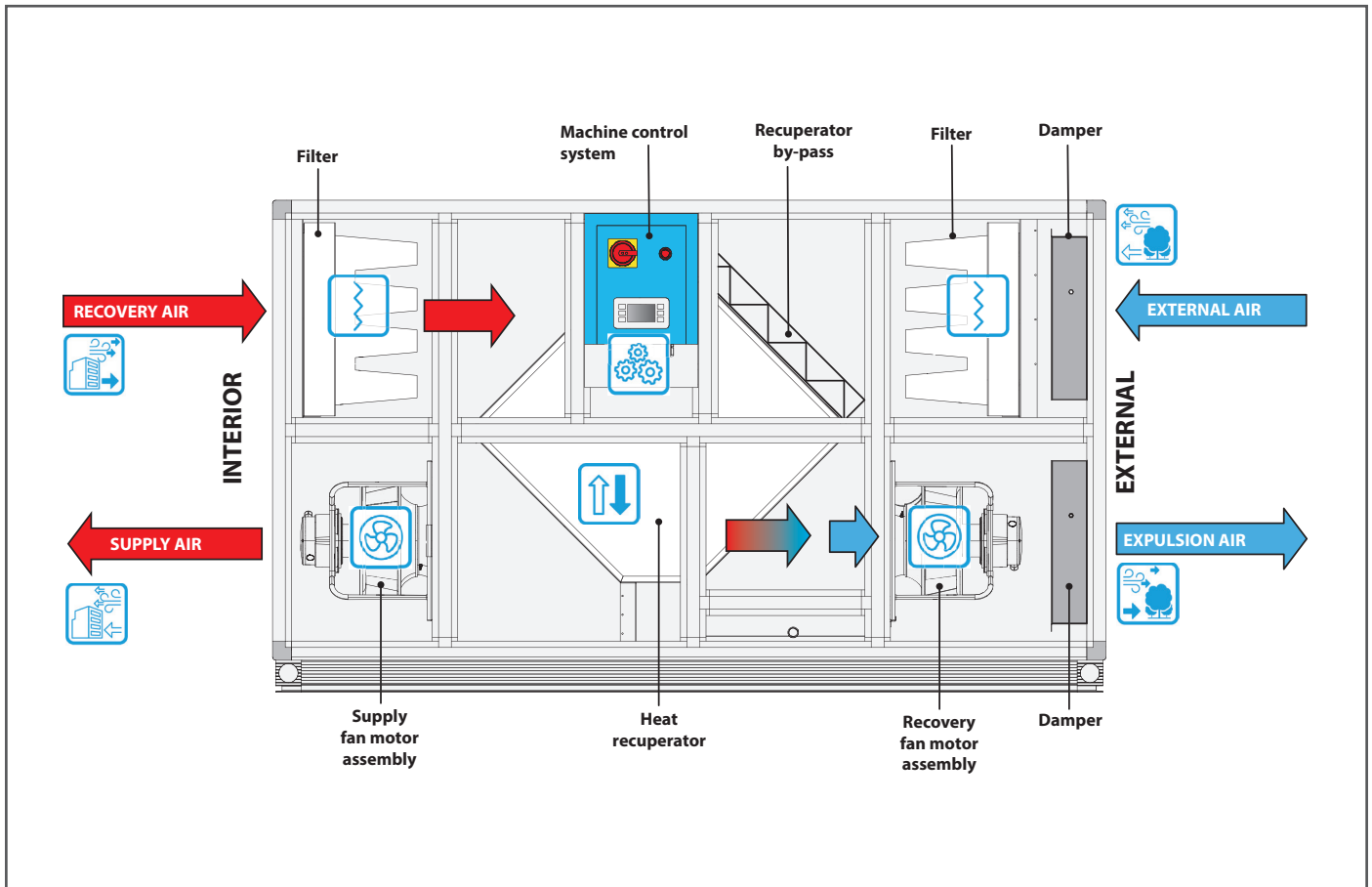



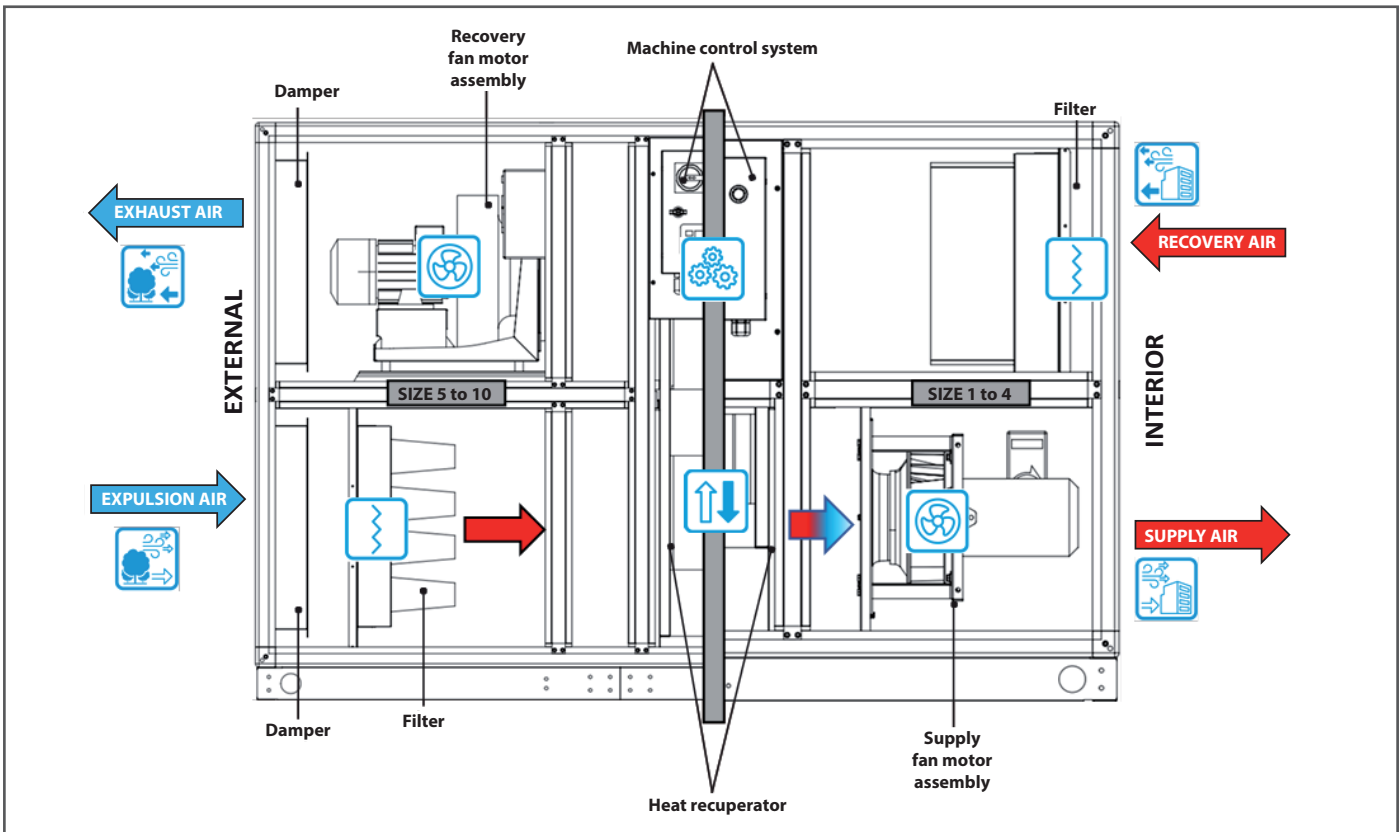
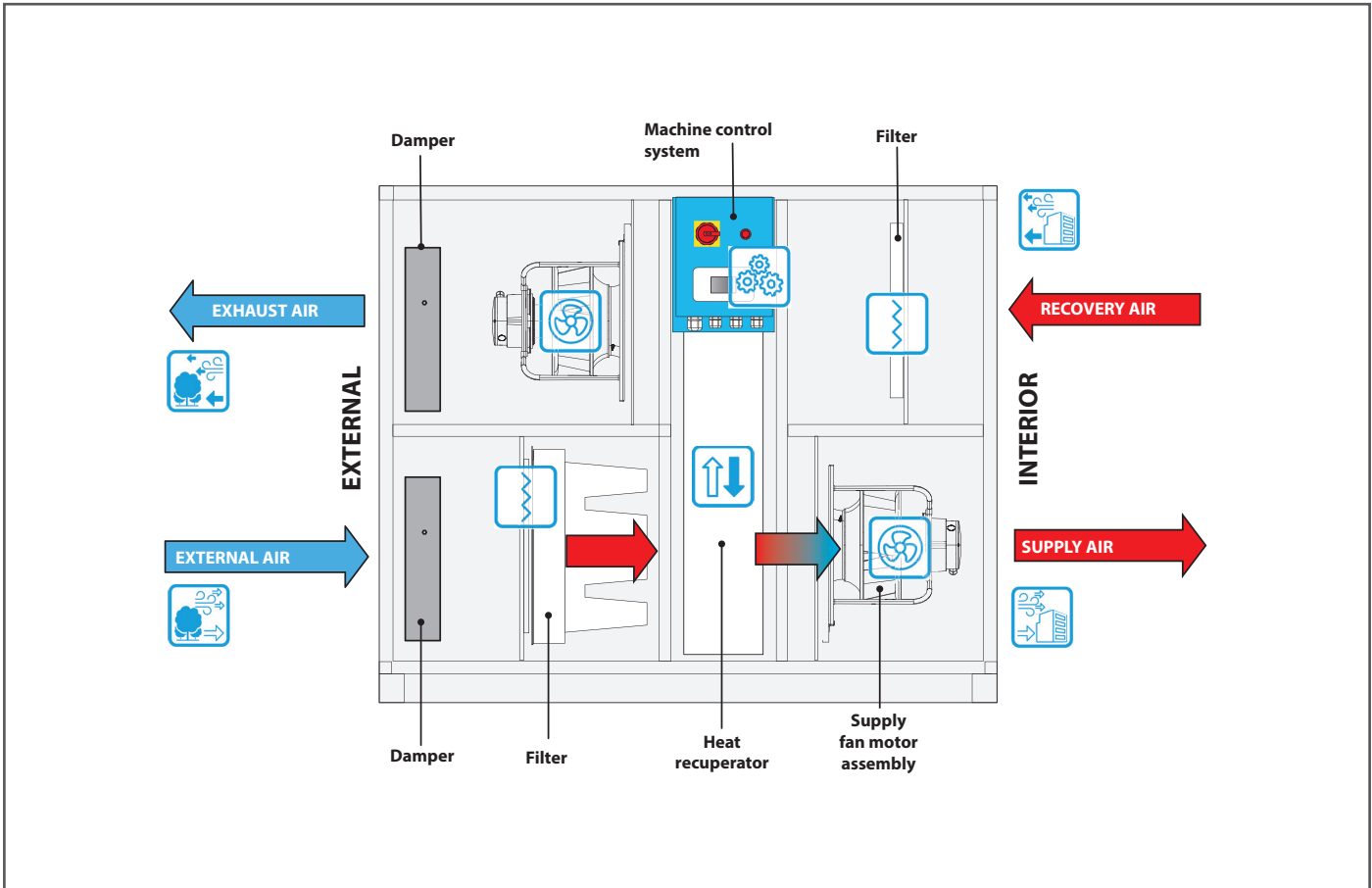



















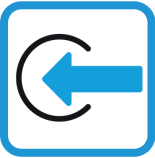

**1** operational diagram of a left-hand machine (MODULAR PLATE)

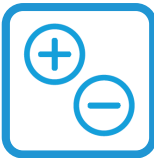

**2** operational diagram of a right-hand machine (MODULAR ROTARY)

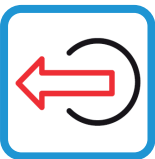
# Adhesives on the machine

The following table describes the meaning of the various adhesives on the unit.

	External air right		External air left		Damper
	Exhaust air right		Exhaust air left		Drop separator
	Air supply right		Air supply left		Fans
	Extracted air right		Extracted air left		Electric coil
	Cold water inlet		Heat recuperator		Liquid coolant inlet
	Hot water inlet		Humidification		Vapour coolant outlet
	Cold water outlet		Heat exchange coil		Condensate drain
	Hot water outlet		Control		
	Filter		Silencer		

# Notes

---

---

---

---

---

---

---

---

---

---

---

---

---

---

---

---

---

---

---

---

---

---

---

---

---

# Machine description (Modular Plate)

## Filters

Particular care is taken in the selection and arrangement of the filters within the section, supplied by certified and internationally recognized producers.

Pocket filters are supplied with the machine. The customer can choose an efficiency class between ePM10 50% and ePM1 80%. Compact prefilters are 48mm thick. The customer can select an efficiency class between ISO Coarse 55% and ePM10 75%, according to ISO 16890. The stability of the filters is guaranteed by an exclusive POLYSEAL fixing system that allows comfortable replacement and excellent seal.

All the filters are equipped with a differential pressure switch that makes it possible to monitor the level of filter blockage. The filters are always mounted to be extracted from the dirty side, to maintain the seal and avoid the release of dust and contaminants into the circuit during replacement.

## Frame with supporting structure

The frame is made of extruded profiles in anodized aluminium with a thermal break, having a 40x40 mm cross-section. Coupling is done with nylon joints reinforced with glass fibre. The profiles are always of the type with concealed screws, double fins, and chamber, making it possible to attach the panels without the screw being visible from inside the machine. This is an advantage, for both aesthetic and safety reasons. If people must work inside the machine for maintenance or cleaning, they can work in total safety without running the risk of injury. The interior of the machine is therefore without protrusions or discontinuities in the profiles.

The units are equipped with a continuous base along the entire base and this is made entirely of aluminium (up to size 07 and in galvanized steel from Size 08 to 10).

The profiles have a thermal break, i.e., they are constructed with an insulating element able to considerably limit the thermal bridges towards the outside. This technology allows reducing condensation on external surfaces and improves the thermal insulation of the machines.

## Seals

Sealing gasket in polyurethane, placed on door and panel ledges.

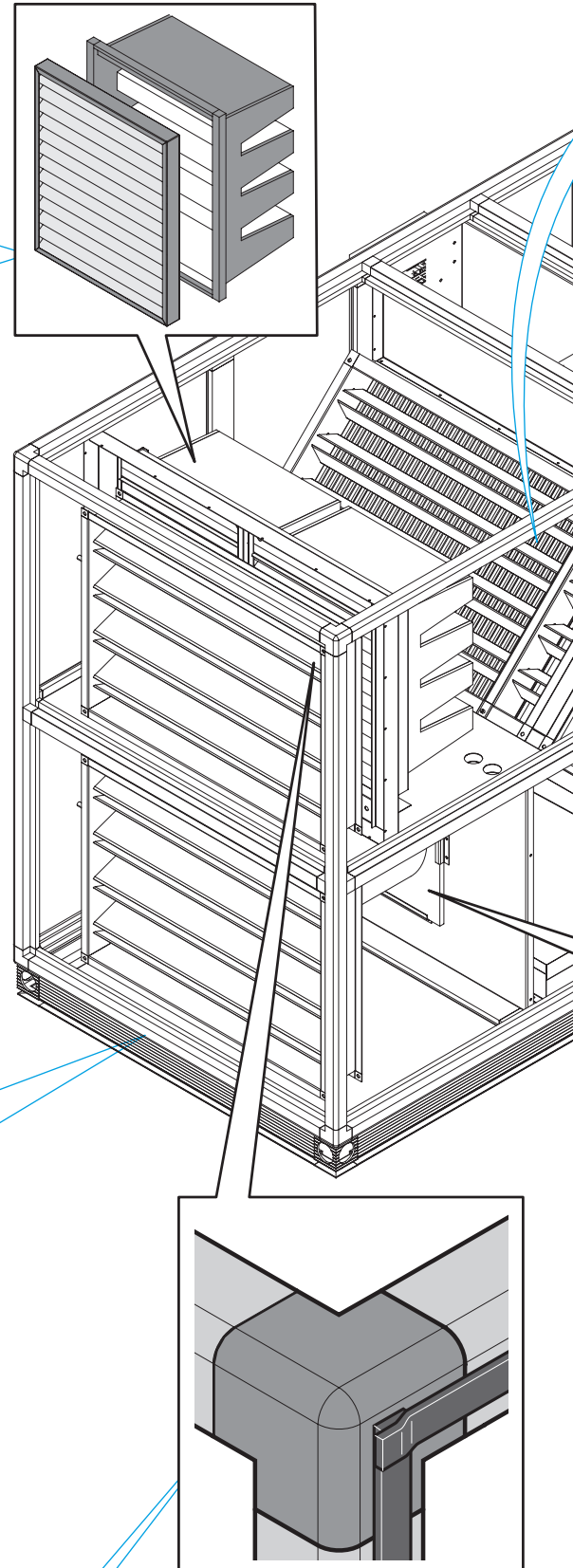



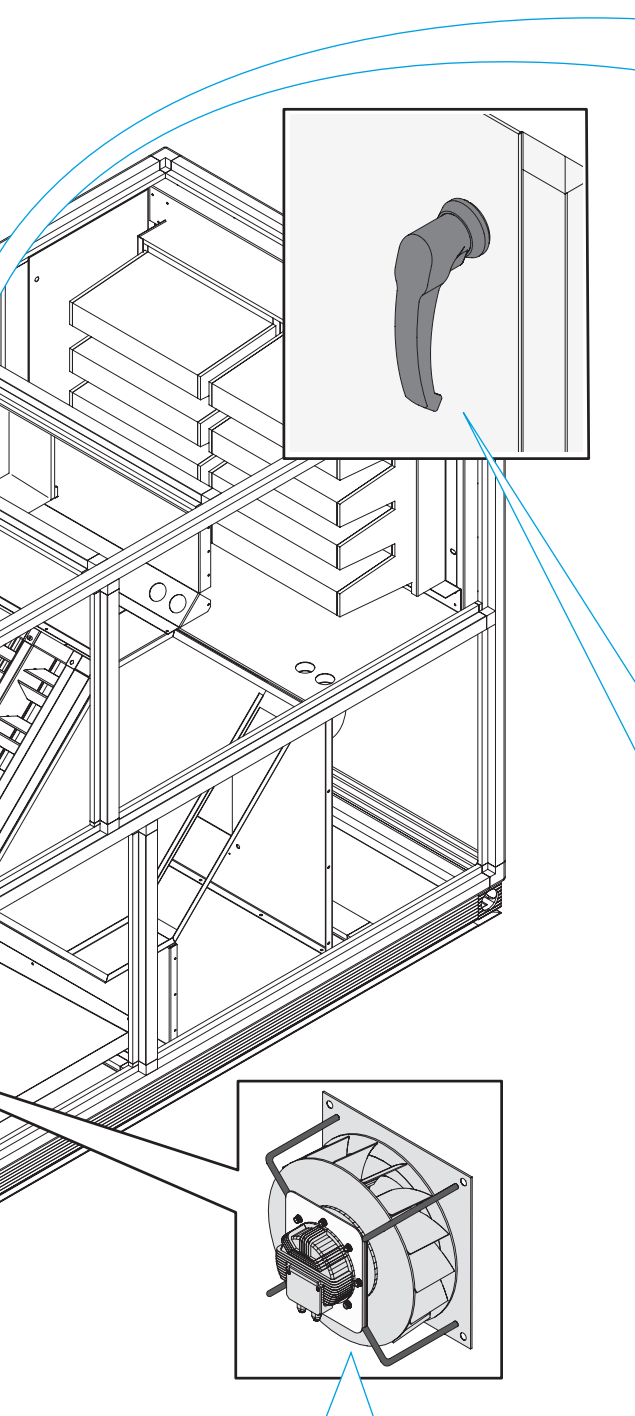

## Heat recuperators

The recovery sections are made using counterflow recuperators (Modular P). The exchange of energy between the outdoor air and the recovered air makes it possible to pre-treat the supply air, lowering the heat output necessary for the complete treatment.

## Doors and handles

Each door of the ventilating sections is equipped with a security key, thus allowing access only to authorized personnel. All locking handles on the same machine are identical.

## Hinges

The hinges are made of black painted Zamak alloy.

## Panels

The panels are made of double sheet metal folded into a box enclosing the hot-injected polyurethane (density of 45 Kg/m<sup>3</sup> and fire reaction Class 1) or mineral wool (density of 120 Kg/m<sup>3</sup> and fire reaction Class 0).

The material of the external sheet can be customized according to the need for resistance to corrosion, ranging from Aluzinc to pre-painted sheet metal.

The panels are attached with stainless self-drilling screws housed in nylon bushes: the latter are embedded in the panel and include a closing cap.

The use of stepped panels allows coupling with the profiles that guarantees the continuity of the internal surface and a better thermal insulation of the machine.

## Fan motor assemblies

There are 2 types of fans that can be used on the units:

**EC FANS** – these fans use electronically controlled motors that integrate the combined benefits of DC motor on the AC fans. A low-maintenance machine since the motor is directly keyed on the impeller.

**PLUG FANS** – these range of fans consists of free centrifugal impellers. The impellers are keyed with aluminium or steel hubs equipped with a keyway and tightening screws and are normally coupled directly to the motor shaft.

# Machine description (Modular Rotary)

## Filters

Particular care is taken in the selection and arrangement of the filters within the section, supplied by certified and internationally recognized producers.

Pocket filters are supplied with the machine.

The customer can choose an efficiency class between ePM10 50% and ePM1 80%. Compact prefilters are 48mm thick. The customer can select an efficiency class between ISO Coarse 55% and ePM1 80%, according to ISO 16890. The stability of the filters is guaranteed by an POLYSEAL fixing system that allows comfortable replacement and excellent seal.

All the filters are equipped with a differential pressure switch that makes it possible to monitor the level of filter blockage. The filters are always mounted to be extracted from the dirty side, to maintain the seal and avoid the release of dust and contaminants into the circuit during replacement.

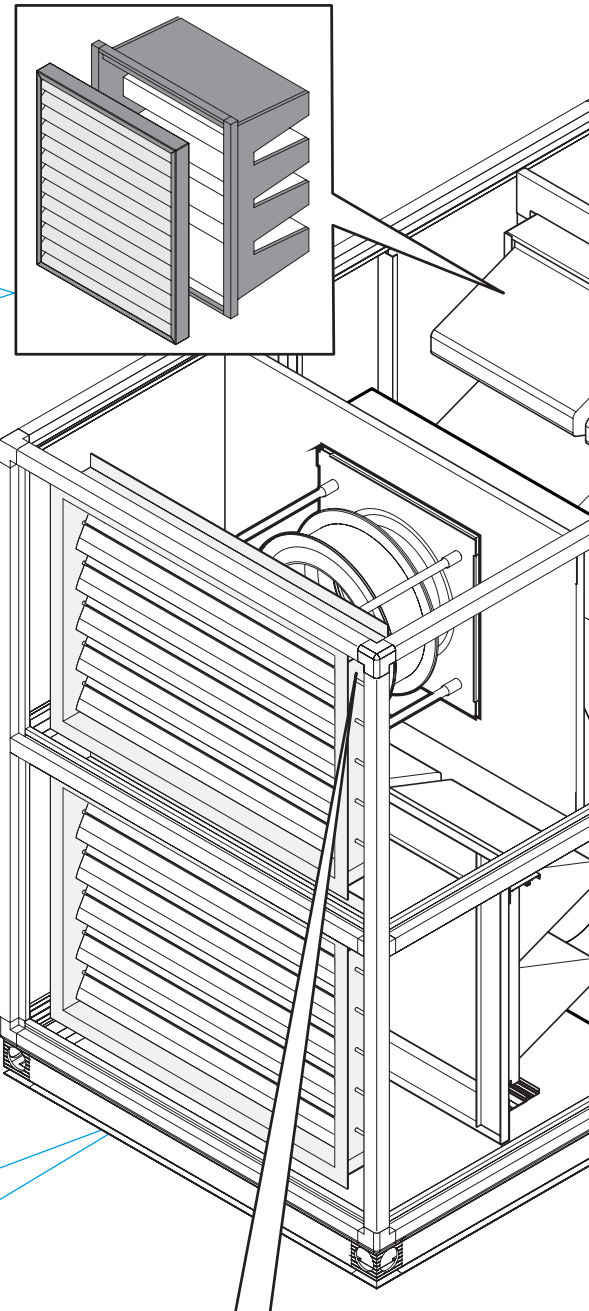

## Frame with supporting structure

The frame is made of extruded profiles in anodized aluminium with a thermal break, having a 40x40 mm cross-section. Coupling is done with nylon joints reinforced with glass fibre. The profiles are always of the type with concealed screws, double fins, and chamber, making it possible to attach the panels without the screw being visible from inside the machine. This is an advantage both for aesthetic reasons and for safety: if people must work inside the machine for maintenance or cleaning, they can work in total safety without running the risk of injury. The interior of the machine is therefore without protrusions or discontinuities in the profiles.

The units are equipped with a continuous base along the entire length and is made entirely of aluminium.

The profiles have a thermal break, i.e., they are constructed with an insulating element able to considerably limit the thermal bridges towards the outside. This technology avoids condensation problems on external surfaces and improves the thermal insulation of the machines.

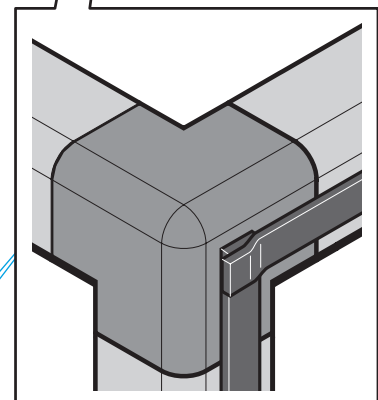

## Seals

Sealing gasket in polyurethane, placed on door and panel ledges.

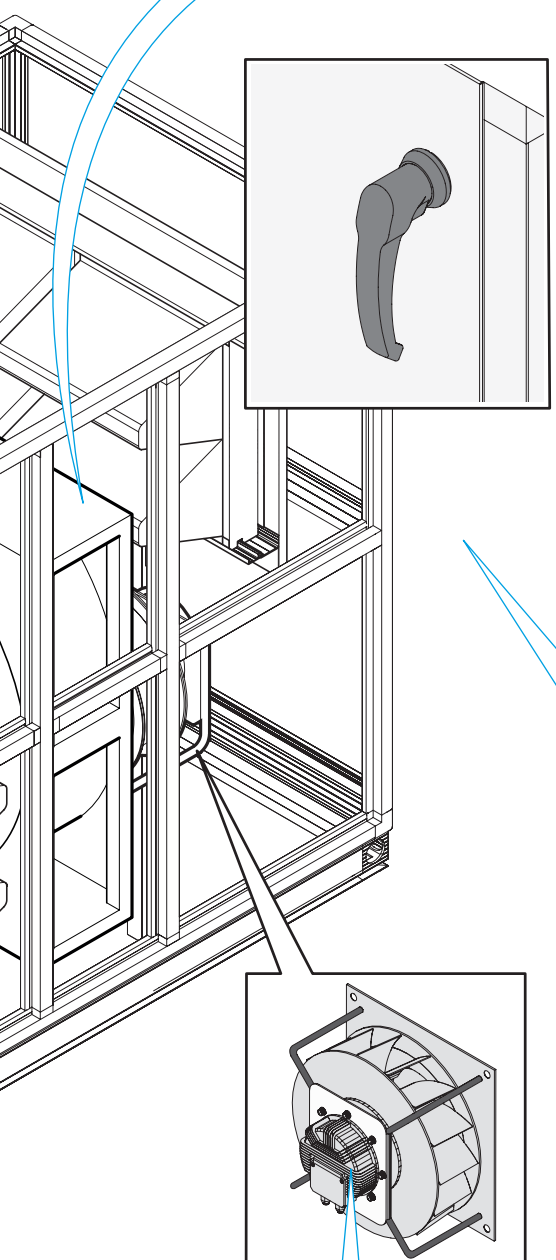

## Rotary recuperators

All the rotary recuperators supplied comply with the latest directives and regulations applicable to safety, performance and labelling in force within the European Community.

There are "sorption" and condensing models, chosen by the customer during the selection phase.

Each recuperator is equipped with a motor and transmission with belt and pulley.

The inverter has a 230V/1ph/50-60Hz input power supply, 230V/3ph output power supply to the motor, IP54 protection degree, 0-10V control analogue input, alarm relay output. Each rotary recuperator is equipped with an air-tight brush-type seal with an internal plastic blade which ensures greater seal along the entire perimeter of the wheel.

## Doors and handles

Each door of the ventilating sections is equipped with a security key, thus allowing access only to authorized personnel. All locking handles on the same machine are identical.

## Hinges

The hinges are made of black painted zamak alloy.

## Panels

The panels are made of double sheet metal folded into a box enclosing the hot-injected polyurethane (density of 45 Kg/m<sup>3</sup> and fire reaction Class 1) or mineral wool (density of 120 Kg/m<sup>3</sup> and fire reaction Class 0).

## Fan motor assemblies

There are 2 types of fans that can be used on the units:

**EC FANS** – these fans use electronically controlled motors that integrate the combined benefits of DC motor on the AC fans. A low-maintenance machine since the motor is directly keyed on the impeller.

**PLUG FANS** – these range of fans consists of free centrifugal impellers. The impellers are keyed with aluminium or steel hubs equipped with a keyway and tightening screws and are normally coupled directly to the motor shaft.

## Parts and accessories

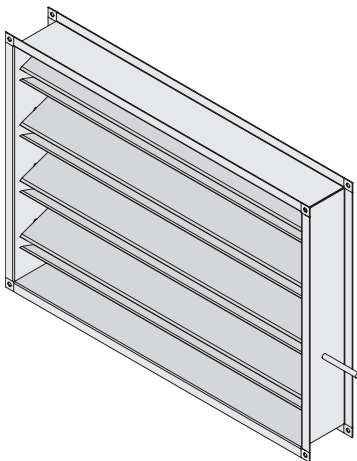

### Dampers

The dampers of the Modular range are all made of aluminium with gasket, with class II seal according to EN 1751. The external and exhaust air dampers can be equipped with a rainproof system or an anti-pest net.

### Internal structure

The internal sheets used for attaching components like fans, filters and recuperators are entirely made of Aluzinc, guaranteeing high resistance to corrosion. All points of contact with the internal section are equipped with gaskets to ensure a superior seal against air leakage. The condensate collection tanks in the counter flow recuperators (Modular P) are made entirely of stainless steel, thus ensuring maximum durability. The welds of the exhaust pipe and of the edges are made of continuous wire in an inert gas atmosphere.

### Heat exchange coils (Only in the coil module)

The heat exchange coils are of the finned pack type. This component is made of copper tubes, aluminium frame, and BLUE FIN aluminium fins. Depending on the choices, the coils can use water or direct expansion. In both cases, the battery is controlled. In the case of DX units are supplied with "ERQ Daikin" control board and "Daikin" electronic expansion valve mounted and connected. In the case of water batteries, the control is entrusted to a three/two-way valve complete with modulating actuator supplied separately.

### Condensate collection basins

The condensate collection tanks in the counter flow recuperators (Modular P) are made entirely of stainless steel, thus ensuring maximum durability. The welds of the exhaust pipe and of the edges are made of continuous wire in an atmosphere of inert gas: all the welds are protected with zinc-based paints.

### Anti-vibration joints

On request, the units can be equipped with anti-vibration joints for the connection of the external air ducts to the machine. These components are flanged and made of fire-retardant PVC-coated polyester fabric.

### Covering roof

The machines for outdoor use can be equipped with Aluzinc roofs, resistant to corrosion and therefore ensuring the extreme durability of the component.

### Silencers

With drawstring with 100 mm thick silencing partitions. The silencers are built according to the VDI6022 hygiene standard and the silencing material is rock wool protected by a flake-proof film compliant with the VDI6022 standard.

# 3 Receipt of the cartons



Handle the equipment following the Manufacturer's instructions on the packaging and in this manual. Always use personal protective equipment.

The means and method of transport must be chosen by the transport operator according to the type, weight, and size of the machine. If necessary, draw up a "safety plan" to guarantee the safety of the people directly involved.



Upon receipt of the machine check the integrity of the packaging and the number of parcels sent:

- A) There is visible damage/one or more cartons is missing: **do not** install, but **promptly** notify the Manufacturer and the carrier that made the delivery.
- B) There is NO visible damage: move the machine to the site of installation.

## Read the packaging symbols

Externally, the packaging bears all the information necessary to transport the equipment safely: compliance with these instructions ensures operators are safe and prevents any damages to the equipment.

The figure shows the symbols applied to the packaging:



Indicates top and bottom



Indicates that the package must be stored in a dry place because its contents are sensitive to humidity



Shows that the package must be handled with care because its contents are fragile



Shows the package's centre of gravity





Shows the position of the cables so that the package can be lifted correctly









Shows the maximum weight that can be placed on top of the package

# 4 Transport



-  Packages can be handled with a lifting hook or pallet truck of suitable capacity. The choice of the most suitable means and method lies with the operator.
-  The operating area must be perfectly free from objects or people not involved in the transport.
-  If the unit is moved using hooks, use some spreader bars between the lifting cables to prevent damage to the unit and ensure no excessive stress is placed on the side panels.

## Lifting using hooks

-  Use hooks with a capacity adequate to the weight of the package to be lifted. Make sure that the safety latch is in the correct position while lifting.
-  DO NOT move the equipment if the field of vision is poor or there are obstacles along the way (e.g., electric cables, beams, etc.). When the loads are lifted, the range of action of the lifting equipment must remain free of persons.
-  Use perfectly serviceable hooks, chains or steel cables of adequate capacity and material, without any joints or extensions. To guarantee efficiency, carry out periodic checks.
-  Make sure the ground the lifting equipment rests on is stable and not subject to subsidence. Check the flatness of the ground. Do not move the lifting device with the machine suspended in the air.
-  Before lifting it, check the position of the centre of gravity and that the equipment is correctly anchored to the lifting points provided, then slowly lift the package to the minimum height necessary and move it carefully to prevent any dangerous vibrations.
-  Avoid sudden stops while lifting or lowering the package, to prevent any dangerous oscillations.

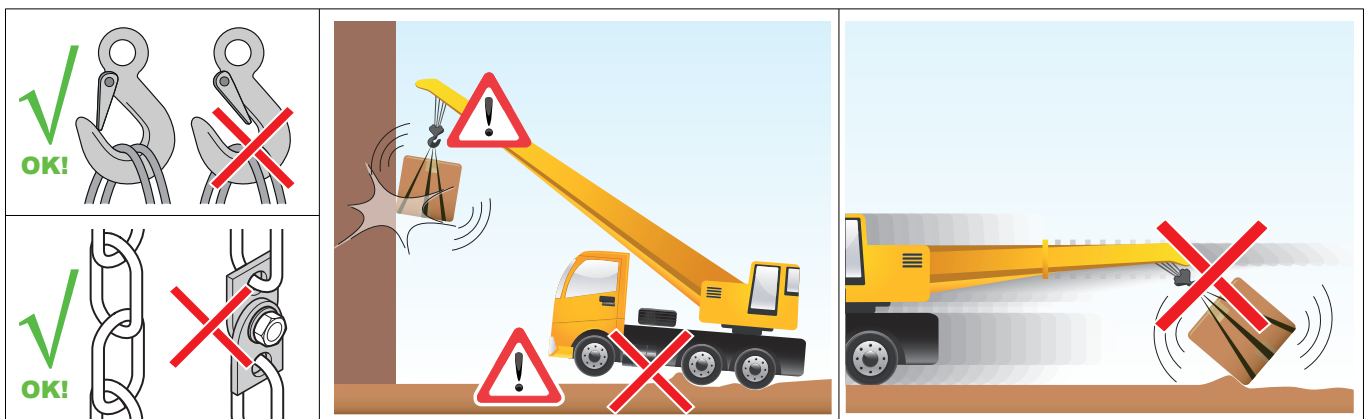

## Lifting with ropes

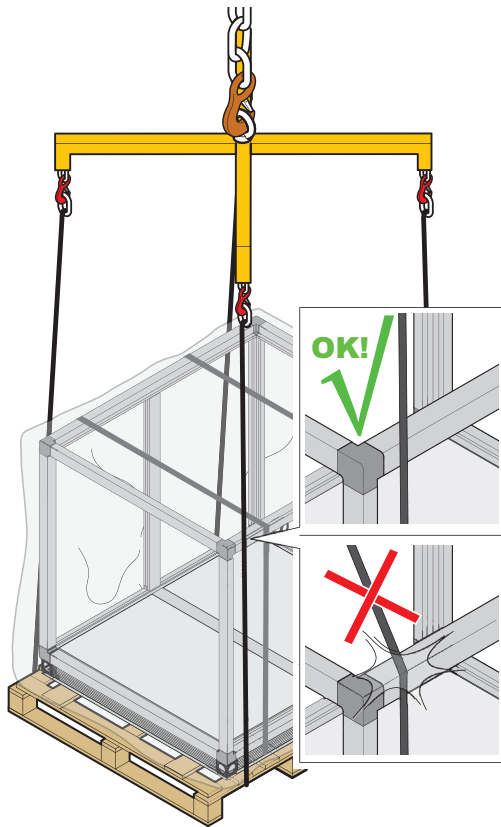

## Lifting with eyebolts

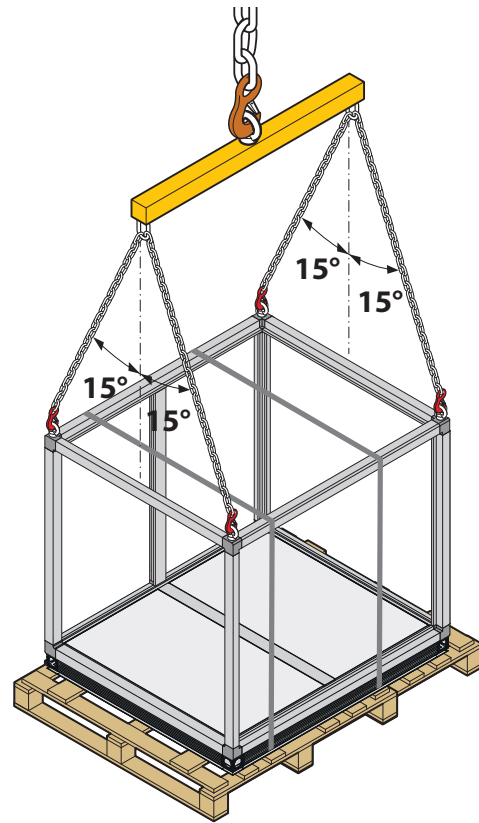

## Lifting with bracket + hook

(up to Size 07 with aluminium base)

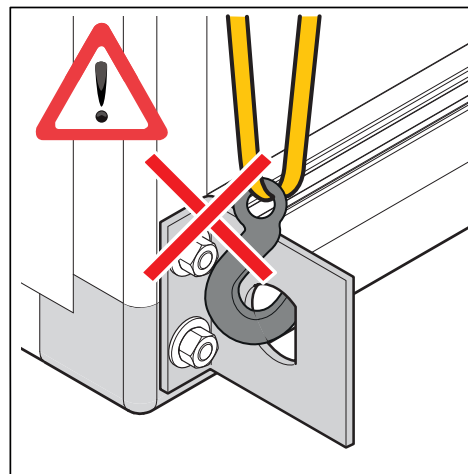
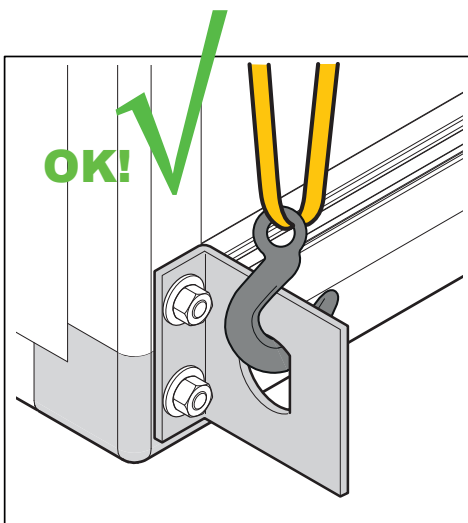

## Lifting using a pallet truck



If transport is done using a pallet truck, make sure it is suitable for the weight and size of the machine. Insert the forks into the points provided for handling (usually in a central position) to keep the centre of gravity of the load in balance. Move the equipment carefully, avoiding sudden movements.

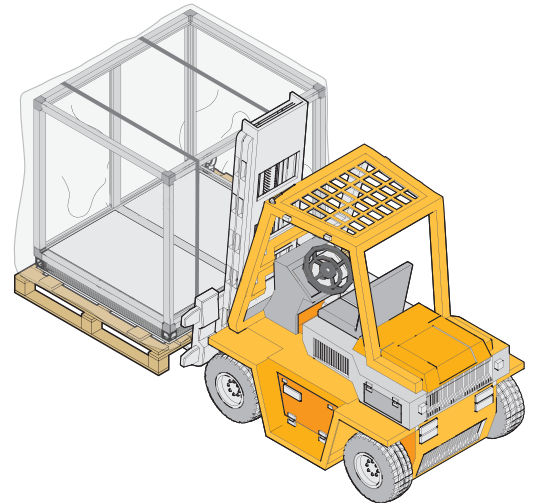

## Lifting non-palletized equipment



The equipment must be lifted using tubes (not supplied) inserted into the holes provided on the apparatus ( $\varnothing$  holes = 60 mm).



The type and diameter of the lifting tubes depend on the weight of the machine to handle. It is the transport operator's responsibility to make the right choice.

Use steel tubes that are in good condition and undamaged.



The ends of the lifting tubes must be closed mechanically to prevent them from coming out of the holes provided.



Position the lifting ropes as shown in the figure, in the part of the tube nearest the equipment.

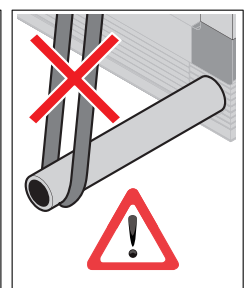
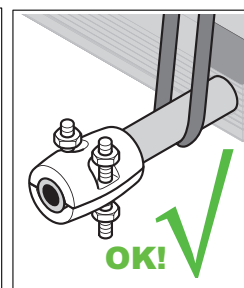
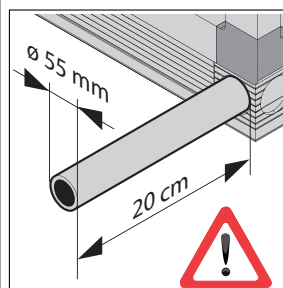
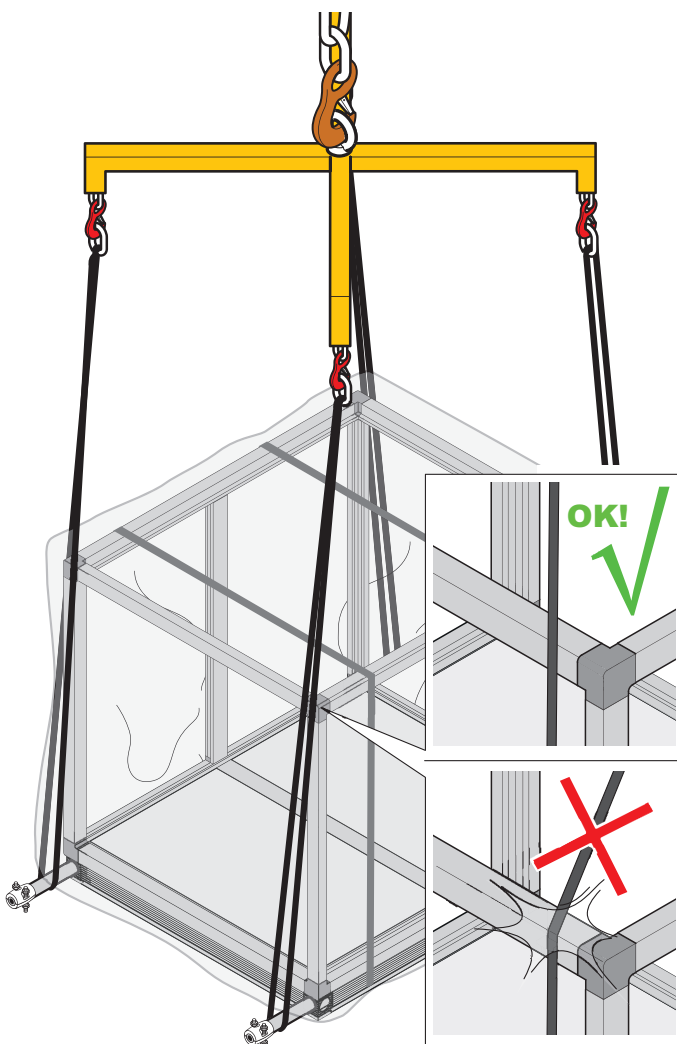



# 5 Unpacking and verification of integrity

We recommend the equipment be unpacked after moving it to its installation location and only when it is to be installed. This operation must be performed using personal protection equipment (i.e., gloves, safety shoes, etc.).

 Do not leave the packing unattended: it is potentially harmful to children and animals (suffocation hazard).

 Some packing materials must be kept for future use (wooden crates, pallets, etc.), while those that cannot be reused (i.e., polystyrene, strapping, etc.) must be disposed of in compliance with the regulations in force in the country of installation: this will protect the environment!

## After unpacking

After unpacking, check the integrity of the machine and any additional modules.

In case of damaged or missing parts.

- **Do not move, install or repair** damaged components and the machine in general.
- **Take quality photos** to document the damage.
- **Find the serial number plate** on the machine and note the machine's serial number;
- Immediately **notify** the carrier that delivered the machine;
- **Promptly** contact the Manufacturer (keep on hand the serial number of your machine).

 Please note that complaints or claims of damage reported after 10 days of receipt of the machine cannot be accepted.

### MANUFACTURER INFORMATION:

DAIKIN APPLIED EUROPE S.P.A.

Via Piani di Santa Maria, 72 - 00072 Ariccia (Roma) - Italy

Tel: (+39) 06 93 73 11 - Fax: (+39) 06 93 74 014

<http://www.daikinapplied.eu>

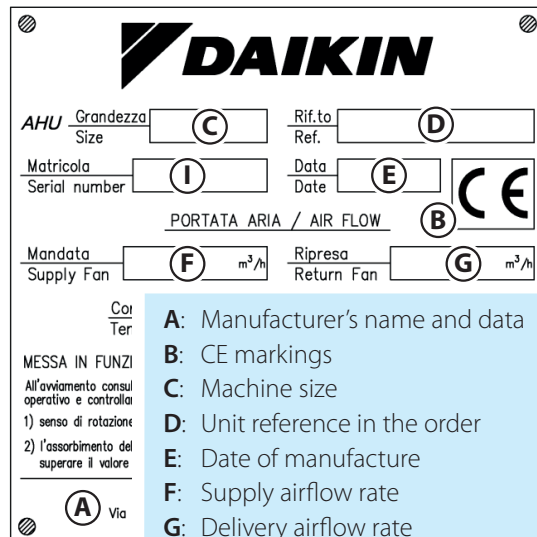

**DAIKIN**

AHU - Grandezza Size **C** Rif. to Ref. **D**

Matricola Serial number **I** Data Date **E** **CE**

PORTATA ARIA / AIR FLOW **B**

Mandata Supply Fan **F** m<sup>3</sup>/h Ripresa Return Fan **G** m<sup>3</sup>/h

Cor Ter **A** Via

MESSA IN FUNZI  
All'avviamento consul operativo e controlla  
1) senso di rotazione  
2) l'assorbimento del superare il valore

- A:** Manufacturer's name and data
- B:** CE markings
- C:** Machine size
- D:** Unit reference in the order
- E:** Date of manufacture
- F:** Supply airflow rate
- G:** Delivery airflow rate
- H:** Electrical specifications (frequency, number of phases, absorption in plate conditions)
- I:** Machine serial number

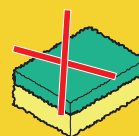
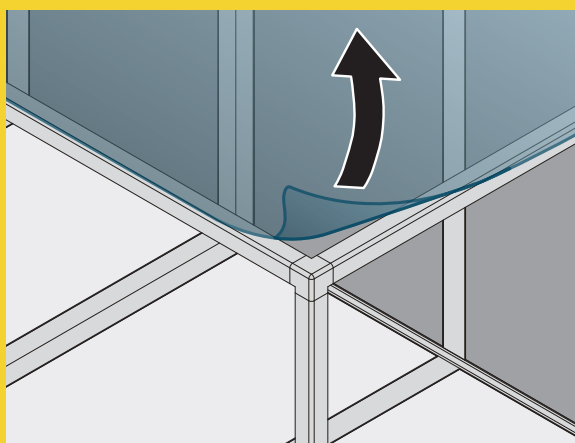

It is important to remove IMMEDIATELY the protective film on both the sides of the top.



# Reading the serial number plate

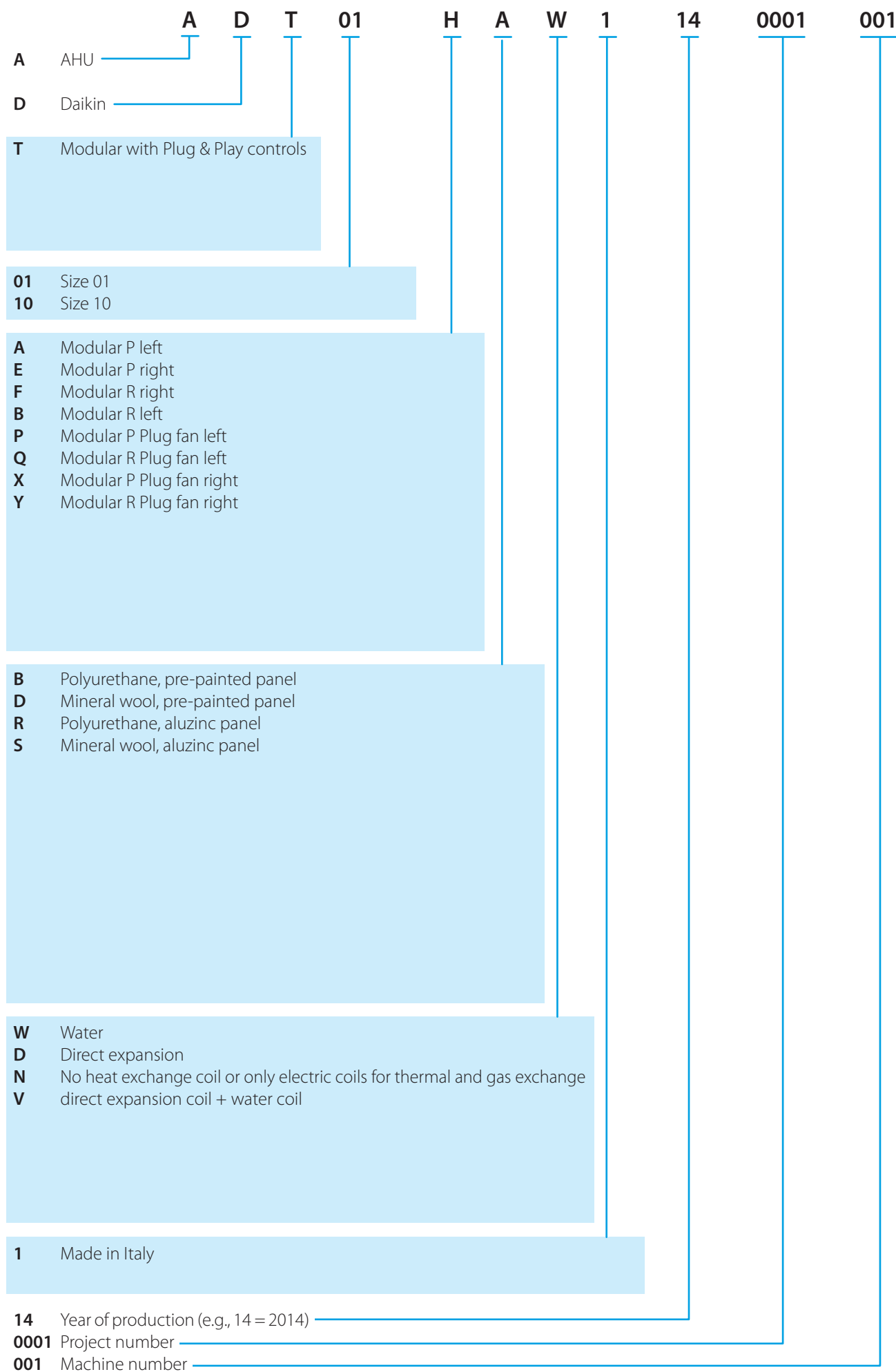

# Storage waiting for installation

Waiting for the installation, the components of the machine and the relative documents must be stored in an area that:

- Is dedicated exclusively to the storage of the components.
- Is covered and protected from the weather (preferably prepare a closed area), with adequate temperature and humidity.
- Is accessible only to operators tasked with the assembly.
- Can support the weight of the equipment (check the load rating) and has a stable floor.
- Is free from other components, especially if they are potentially explosive/incendiary/toxic.



If you cannot proceed with the installation straight away, check periodically that the above-mentioned conditions of the storage area are maintained and cover the machine with a canvas.



While waiting for the finale installation, always provide an insulating base (e.g., wood blocks) between the floor and the machine itself.

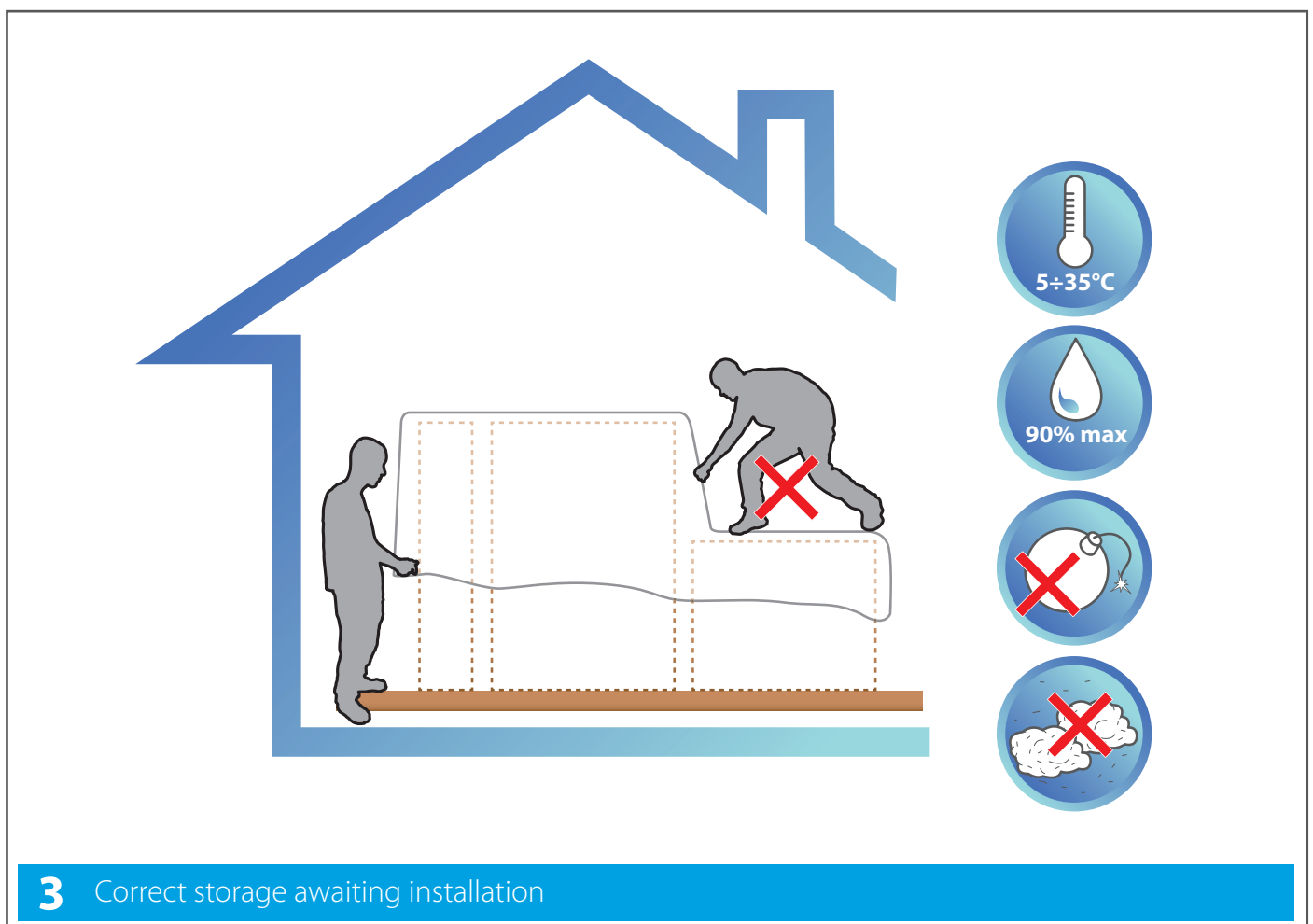

Any movement carried out after unpacking must be done with the doors closed. Do not move the units by pulling on the doors, if present, the uprights or other protruding parts that are not an integral part of the structure.



Do not step on the units!

# Notes

---

---

---

---

---

---

---

---

---

---

---

---

---

---

---

---

---

---

---

---

---

---

---

---

---

---

---

---

---

---

# 6 Installation



All installation, assembly, electrical connections to the mains and extraordinary maintenance must be performed **only by qualified personnel authorized by the Retailer or Manufacturer**, in compliance with the regulations in force in the country the equipment is to be used and the standards on the systems and safety in the workplace.



During installation, the area must be free from people and objects not used for the assembly.



Before starting, make sure you have all the necessary equipment.

Use only equipment that is in good condition and undamaged.



There are two different types of hooks, refer to the assembly instructions for the one in your possession. Any movement carried out after unpacking must be done with the doors closed. Do not move the units by pulling on the doors, if present, the uprights or other protruding parts that are not an integral part of the structure.

Do not step on the units!

Before proceeding with the installation of the machine, it is necessary to prepare the power supplies and utilities necessary for the correct operation of the system and, if required, consulting in advance with the Manufacturer's Technical Office.

The machine does not require special environmental conditions for its operation. For a correct installation it is sufficient to prepare a level support surface, indispensable for the correct operation of the machine and to guarantee the regular opening of the inspection doors.

The altitude of the installation room must be less than 1,000 meters above sea level (at higher altitudes the electric motors deliver powers lower than the nominal ones).

The installation in the workplace must be done in such a way that the machine and its equipment are accessible to allow it to start, stop and carry out maintenance work on the machine.

For the choice of location, in general, care must be taken that an operator can move around the machine without hindrance. The minimum distance to the nearest wall must in any case be at least equal to the width of the machine.

Where there are no means of transport to move the machine, its positioning must consider the free space required for any repairs. It is of course necessary to plan enough space for regular operation, as well as for machine maintenance, including all the space for any peripheral equipment.

To operate the machine requires:

- Electrical connections,
- Water connection,
- Air duct connection.

# Installation procedure

Before installation, read the safety instructions on the first pages of this manual. Contact the Manufacturer if any points are unclear or not perfectly understandable. A check mark next to each step will help to confirm complete and proper installation.

<input type="checkbox"/>	Step 1: Position the unit.....	page 31
<input type="checkbox"/>	Step 2: Assemble the unit (if necessary) .....	page 32
<input type="checkbox"/>	Step 3: Fasten the units to the ground (optional) .....	page 35
<input type="checkbox"/>	Step 4: Make the connections .....	page 47
<input type="checkbox"/>	Step 5: Perform a trial run .....	page 59
<input type="checkbox"/>	Step 6: Install the required filters.....	page 60
<input type="checkbox"/>	Step 7: Safety signs.....	page 61

After installation store this manual and the assembly sheet that accompanied the machine in a place that is dry and clean. This way it will be accessible to operators in the future who need to consult it. Do not remove, tear out or write on any part of this manual besides the space set aside for notes:

<b>Installer/maintenance notes</b> <hr/> <hr/> <hr/> <hr/> <hr/> <hr/> <hr/> <hr/>
---

## Step 1: Position the unit

Check that a suitable **base** has been prepared (fig. 4) for the support and installation of the machine. It must be stable, perfectly flat, made of reinforced concrete and have the capacity to support the weight of the machine.



For the size of the base and the weight to be supported, refer to the schematic delivered when the machine was ordered.

The installation site must also include (fig. 4):

- Suitable **drainage** to convey and drain the water in case of accidental breakage of pipes that carry the fluids to the machine.
- An **electrical system** compliant with current regulations and with specifications that meet the needs of the machine.
- A **water/gas connection** (in the case of connection to coils supplied by water or gas).
- A drain pipe with **drain siphon** connected to the sewerage system.
- an **aeraulic system** (ducts for the air to be conveyed to the environments).

Position the unit above the base. Make sure that the area chosen for the placement has **sufficient space** to allow for subsequent installation and maintenance all around the unit (including replacement of any internal components, for example the removal of heat exchange coils, filters, etc.) (fig. 5 indicates the minimum distances to be maintained). It is advisable to check the extraction side of the components before installing the machine.



Warning! The machines were designed to operate in technological spaces or outdoors. They CANNOT operate in environments with explosives, where there is a high presence of dust, high humidity, or high temperatures unless specific modifications are requested during production.

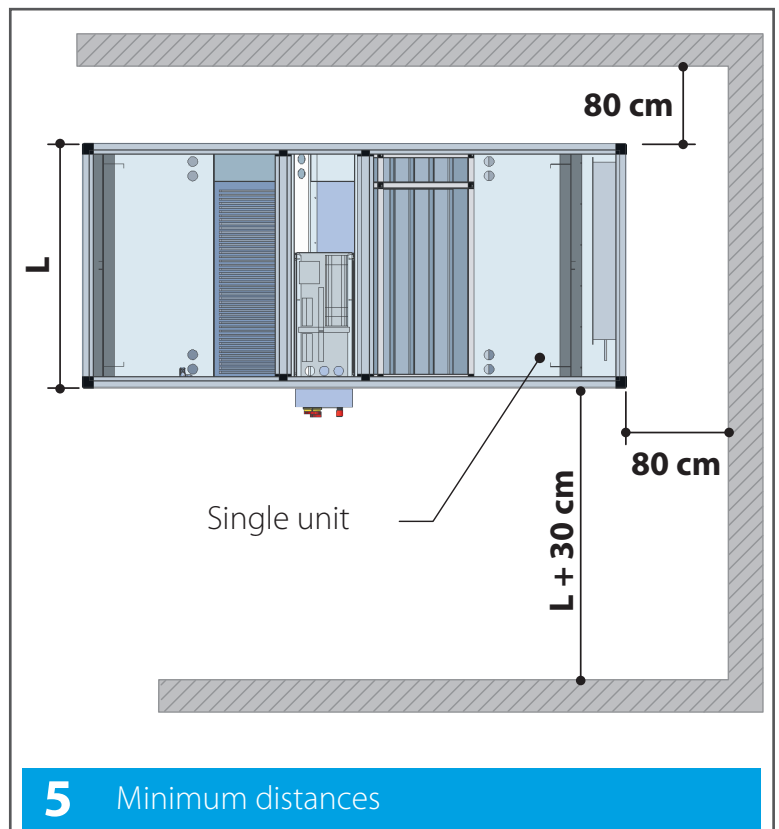
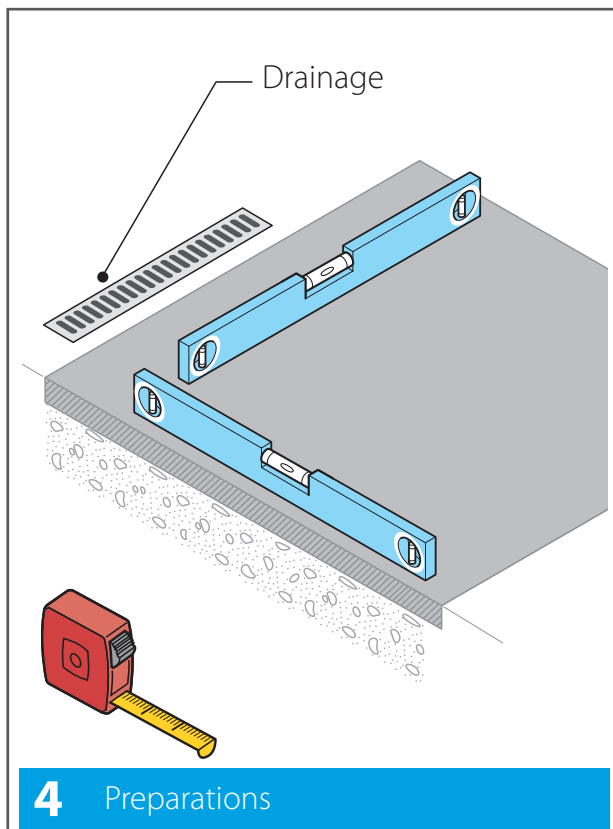

## Step 2: Assemble the unit (if necessary)

If additional modules are required, the units must be assembled directly at the installation site. The necessary components for the assembly of the sections are placed inside a section of the machine, adequately protected.



Gently join the sections after attaching the adhesive seal supplied with the machine on the whole perimeter of contact, just on one side.

Fasten all the coupling screws provided with the machine, and then level the modules. Tighten all the coupling screws entering the units through the inspection doors. Tighten all the other screws, bolts, knobs, and anything else that may have been previously dismantled. It is not recommended to remove fixed panels during installation.



**The drawings on the following pages represent a generic and stylised unit, however the connection procedure is the same for all types of units.**



6

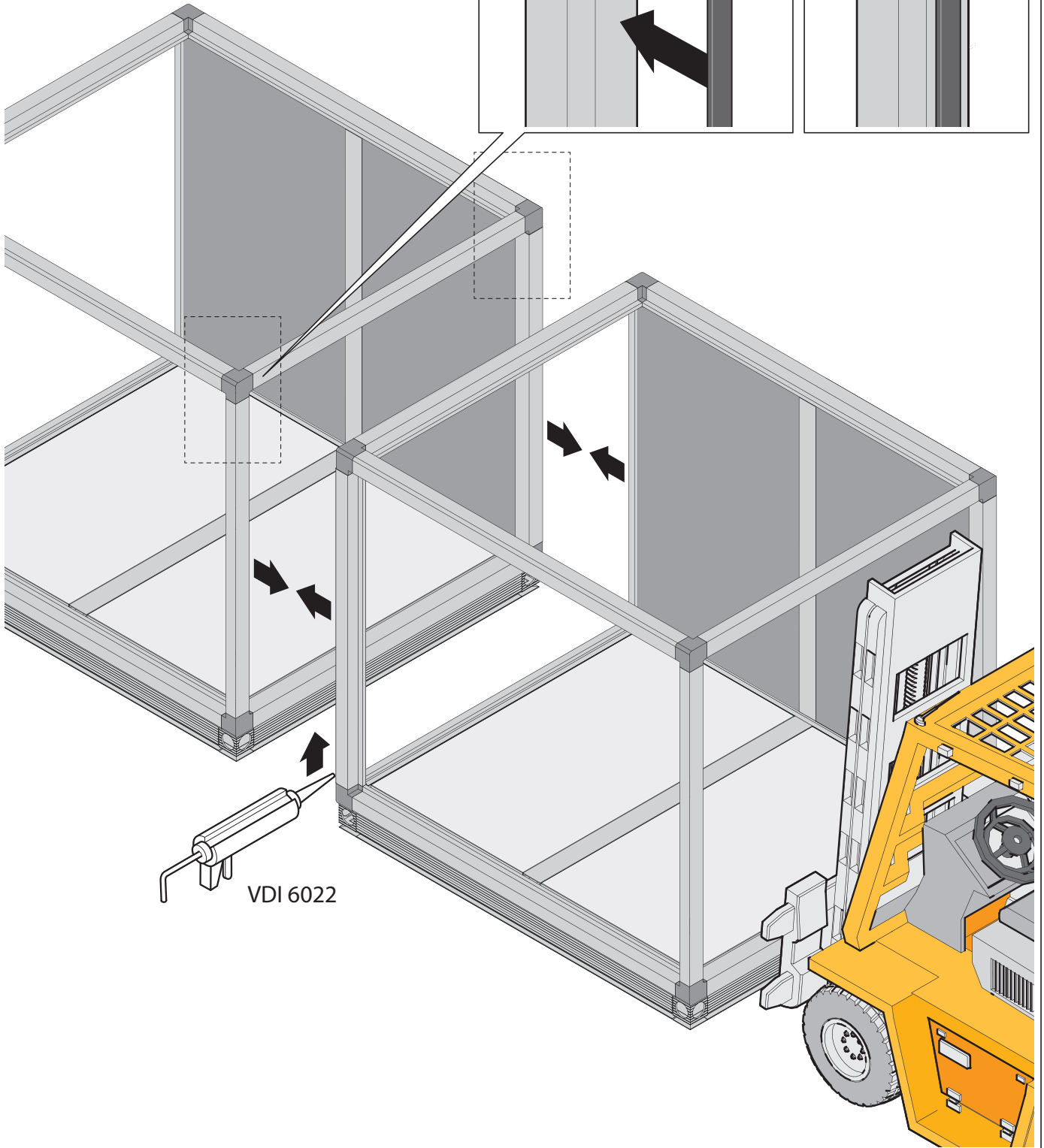
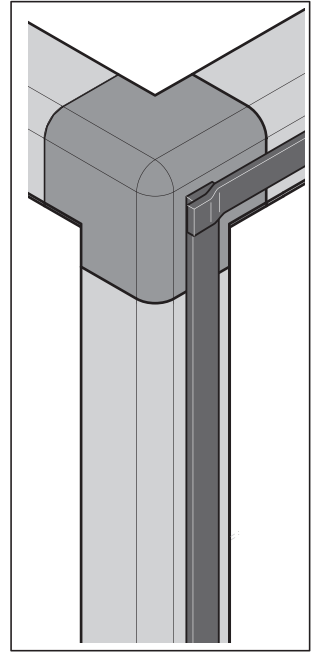
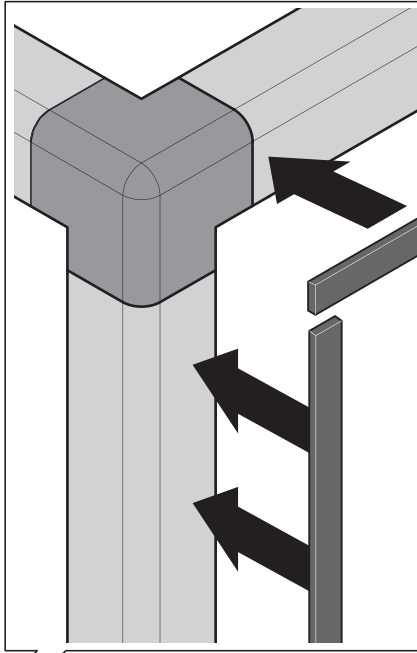
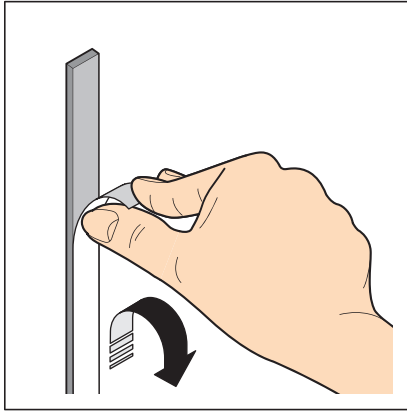

VDI 6022

7

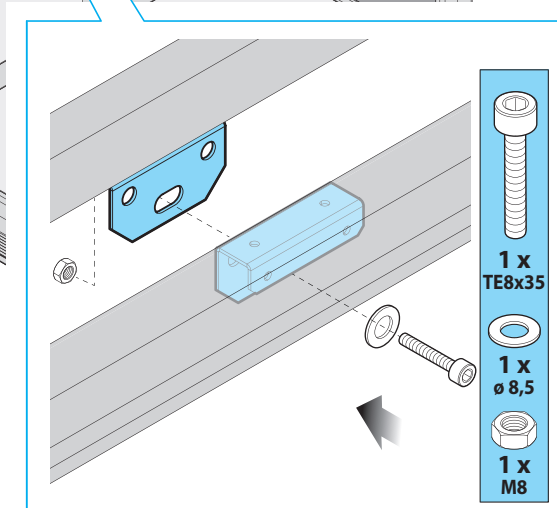
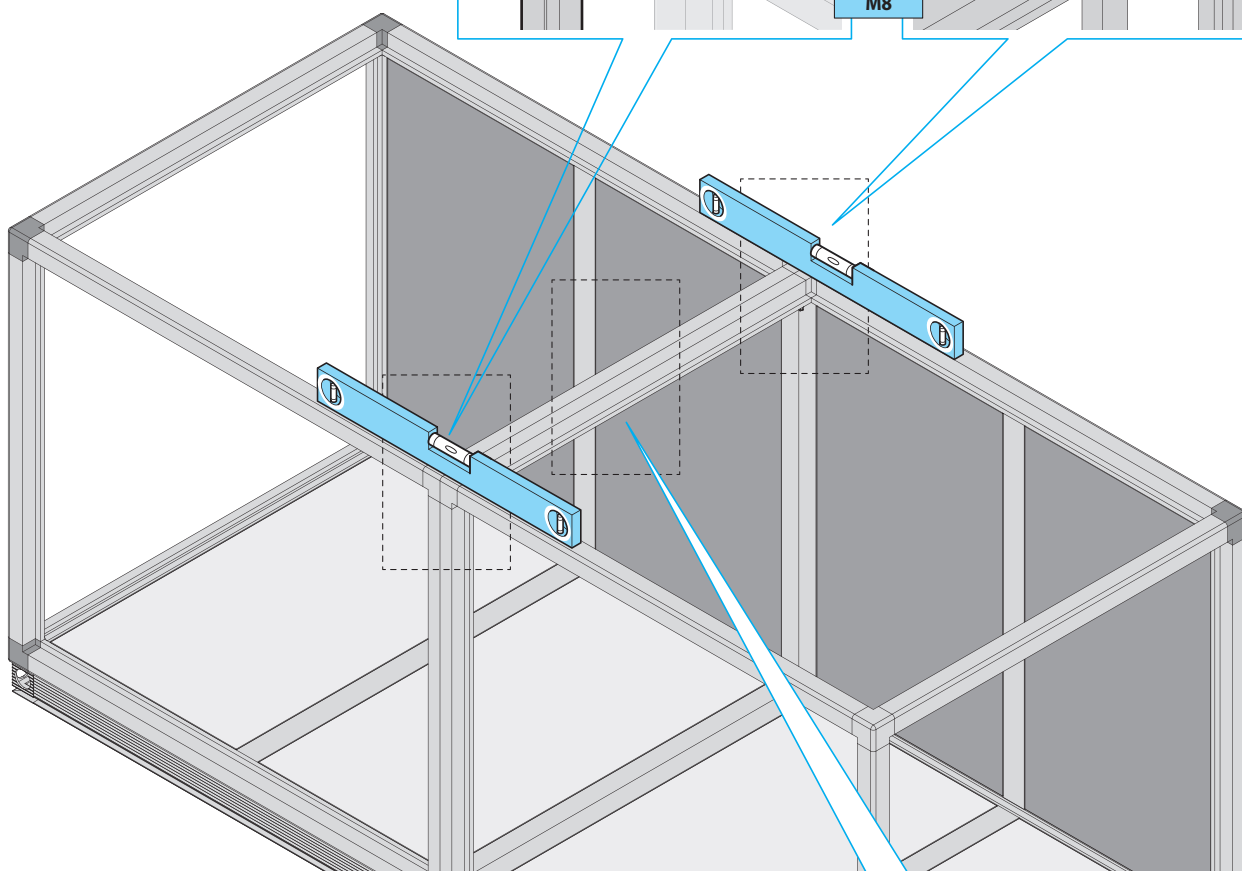
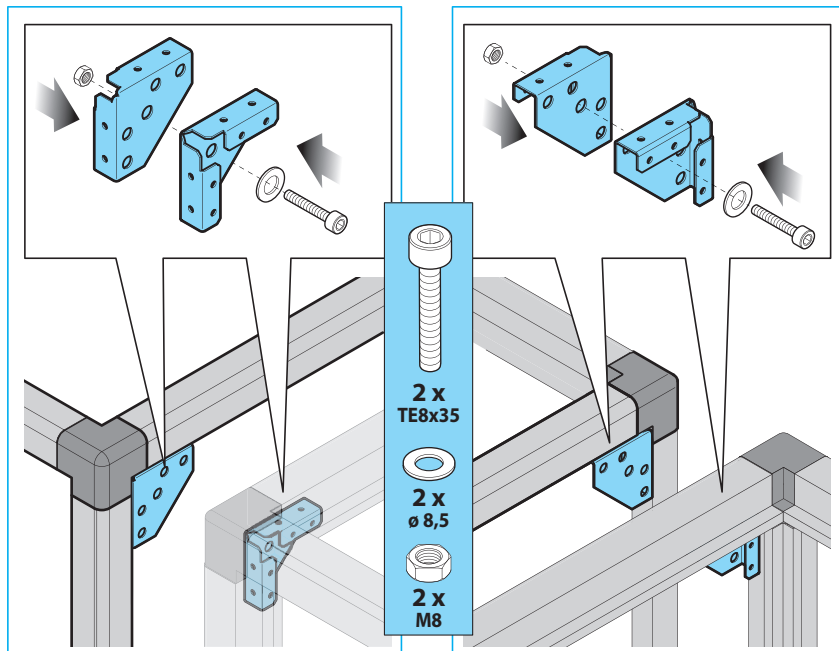

### Step 3: Fasten the units to the ground (optional)

After positioning the units, make sure they are perfectly level, if necessary, inserting suitable solid and stable shims under the supports.

Finish by fastening them to the ground (tools and fastening components not included). The installer is responsible for choosing the most suitable means of fastening based on experience (the drawing includes an example).



There is no need to insert vibration damping material between the machine and the ground as the moving internal parts transmit no residual vibrations to the outside.

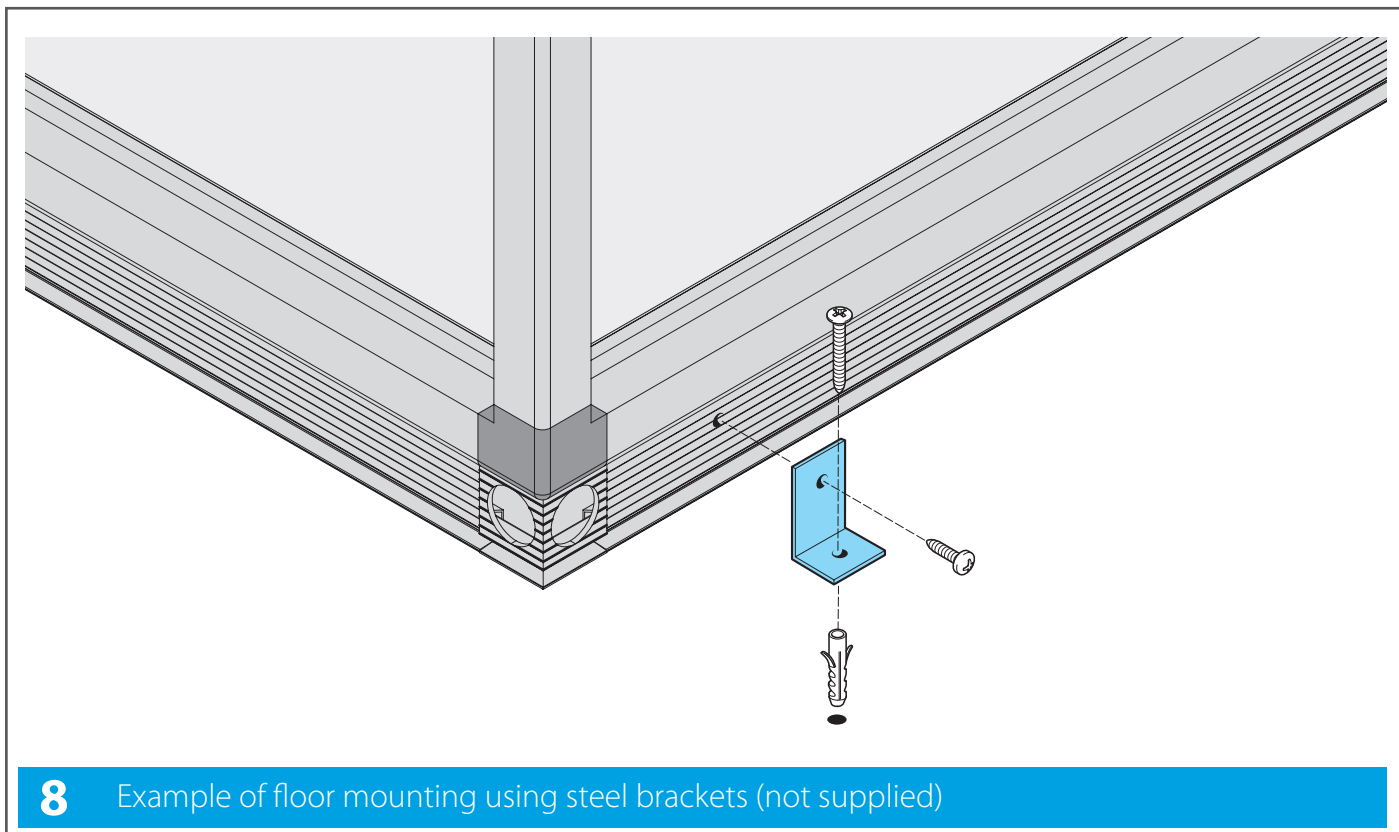

## Rotary heat exchangers

A rotary heat exchanger has seals along the circumference of the wheel and radially to limit the loss between the two air flows.

These seals are made with brush type seals.

The gasket placed on the circumference can be fixed to the rotor or to the frame, depending on the wheel manufacturer. These brushes are fixed with screws with slots to allow their adjustment.



Therefore check that these brushes ensure the correct seal between frame and wheel, without causing excessive friction. The seals can move during transport and therefore must be readjusted at start-up.

The best way to check their condition is with the wheel running. If so, adjust them.

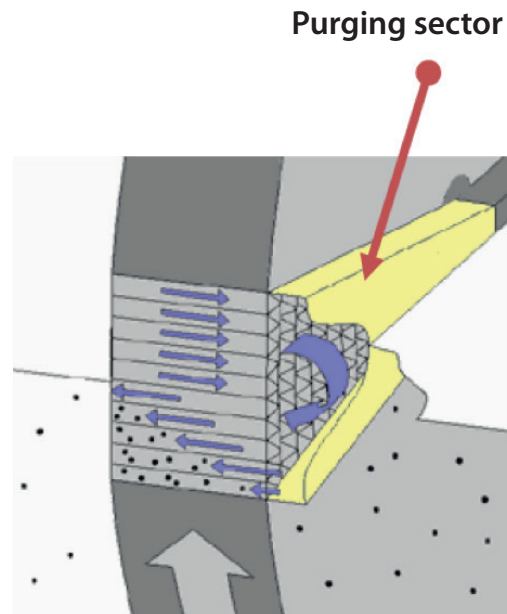

Furthermore, the exchanger can have with a purge sector, which ensures that the rotor matrix is cleaned with fresh air before the rotor portion moves into the delivery sector.

## Transmission belt replacement

The rotary heat exchanger is driven by the **motor (4)** with the **belt (2)** running over the **pulley (3)** and over the circumference of the **rotor (1)**.

The tension on the belt is maintained by the **spiral spring (6)** under the motor **mounting plate (5)**, hinged to the frame. Not all models are equipped with pre-tensioning springs.

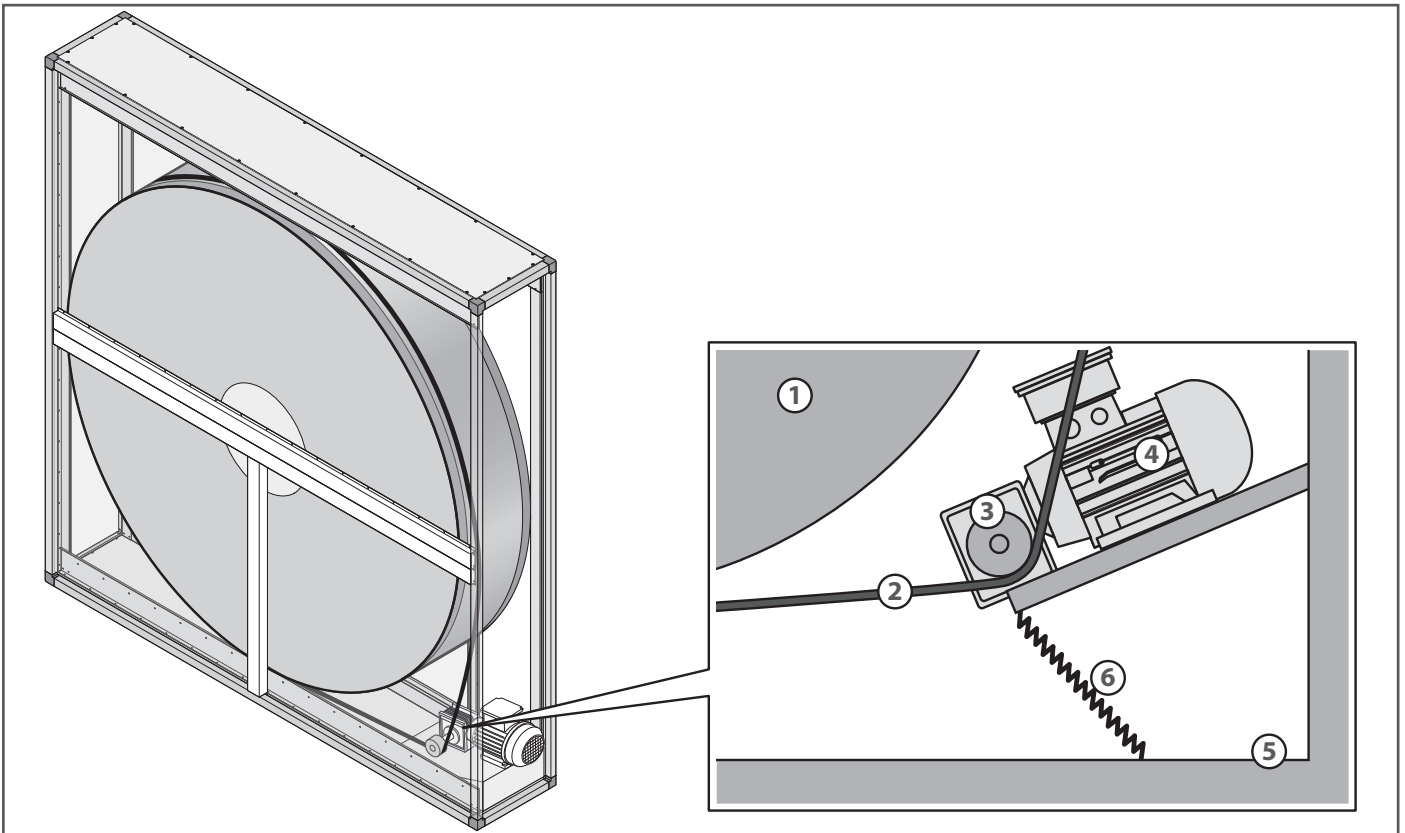

If it is necessary to increase its tension, this can be done removing the belt joint plate and cutting a small portion of the belt itself.

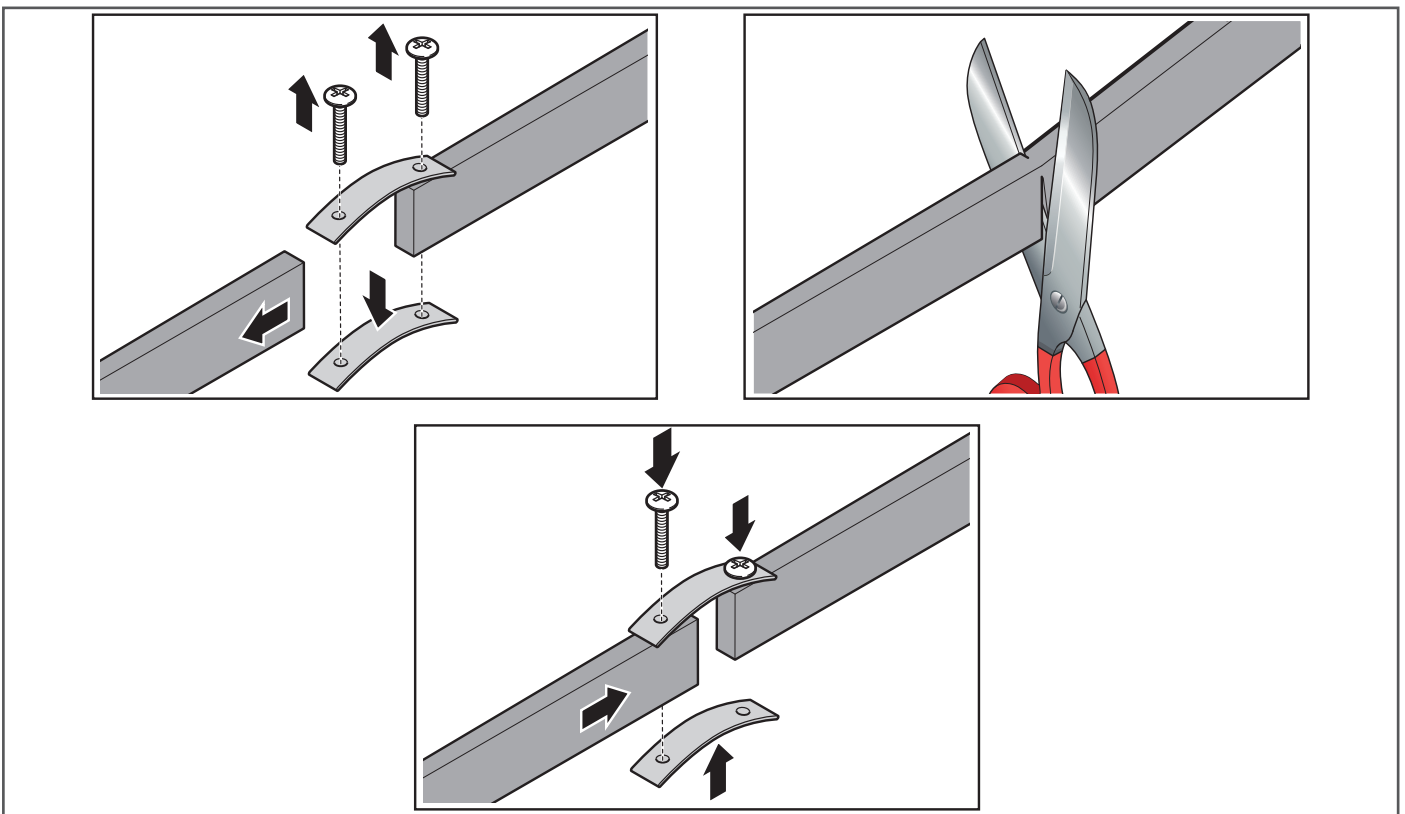

The direction of rotation of a rotary heat exchanger with purge sector must be chosen in such a way that the rotor rotates from the purge sector of the exhaust air to the intake air.

In the illustration, the **pulley (3)** rotates clockwise.

The belt pulling part of the no-bleed rotary heat exchangers should match the centre line through the tension spring as much as possible. The direction of rotation is generally indicated on the rotary heat exchanger.

The direction of rotation must be checked at start-up! The direction of rotation can be reversed by exchanging two phases on the electrical connection to the motor (in the case of direct motor power supply).

## Power supply

### Direct supply

3 x 400V  
Y

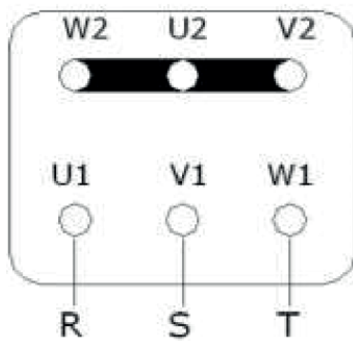

### Powered by VFD or Micromax

3 x 230V  
 $\Delta$

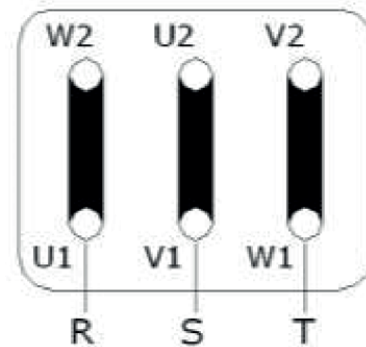

For alignment operations of the rotary wheel and general maintenance operations, refer to the manufacturer's manual supplied.

## Power Twist Belt transmission belt replacement

If there is a **Power Twist Belt** type transmission belt, proceed as follows:

### Measurement

To check the hand-tightened section, it is necessary to tighten the belts around the pulleys, overlapping (in the hand-tight section) the last two tabs with two holes in the corresponding links, as shown in the illustration below; then mark the tabs as shown.

Count the number of links and remove one link every 24 sections.

In this way, a belt of the correct length is obtained and optimum tensioning is ensured during operation.

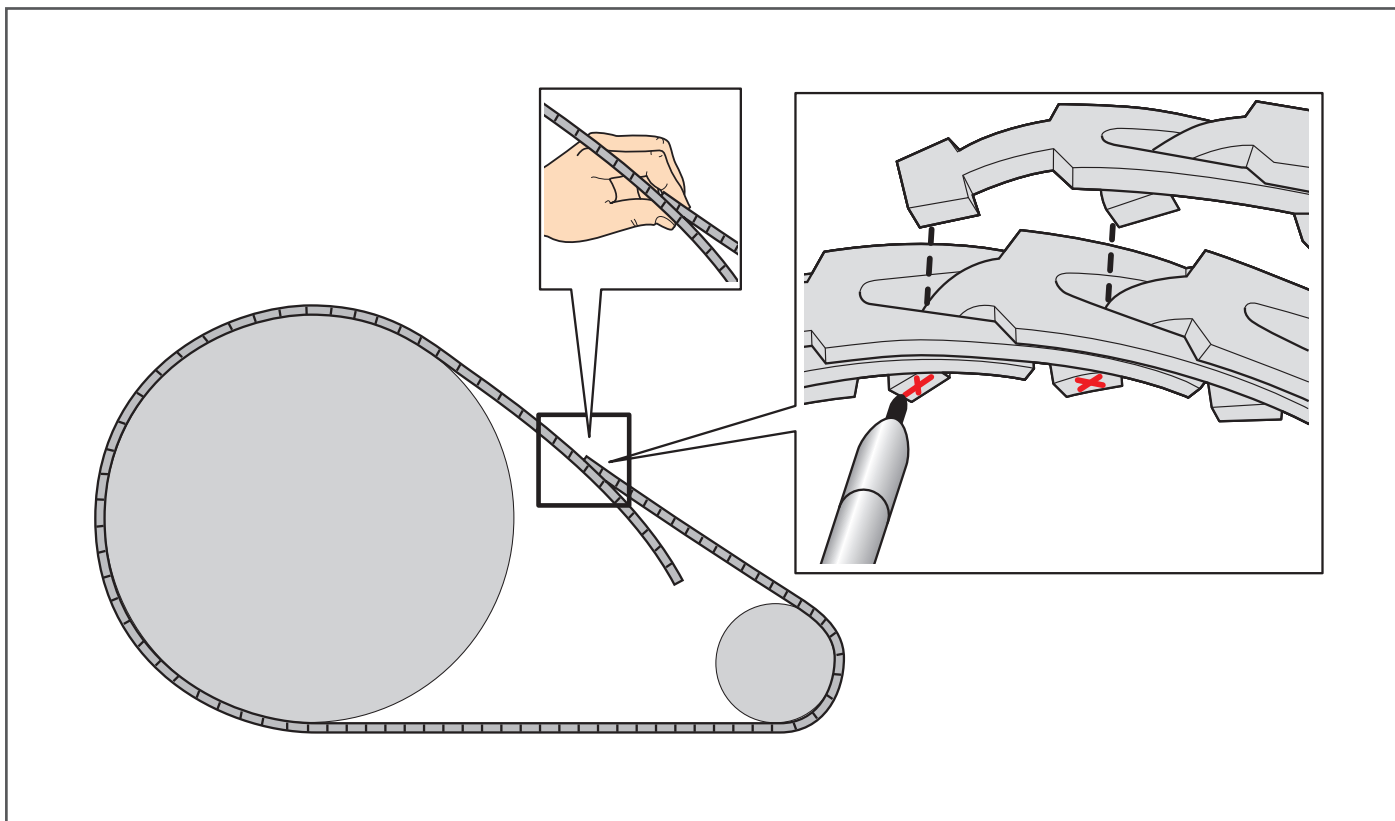

Note: one link every ten has an arrow.

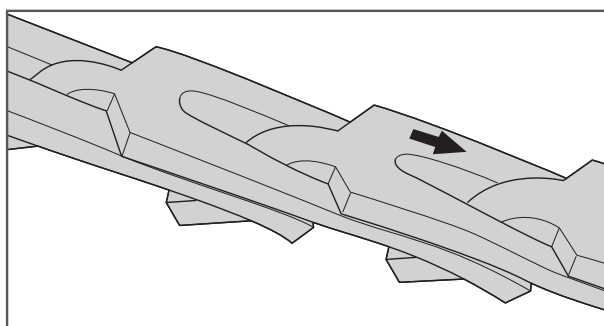

## Link separation



For easier separation of the links, it is advisable to rotate the belt 180° as illustrated below.

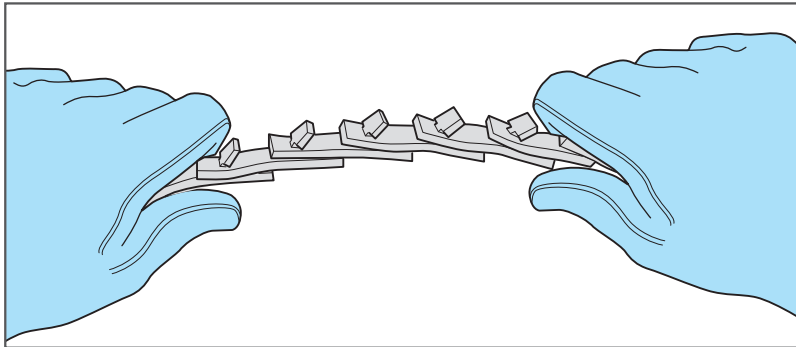

Fold back the belt and grasp it with one hand. Then rotate the first tab 90° parallel to the slot.

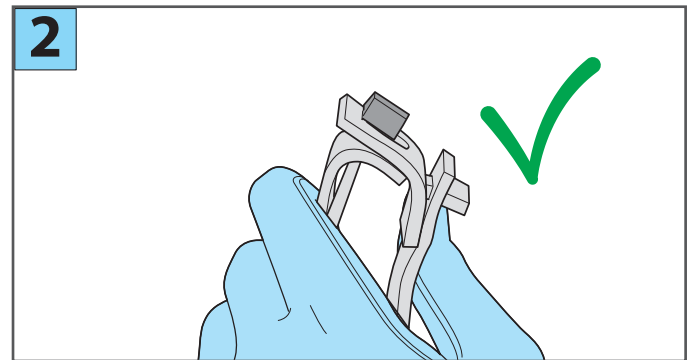
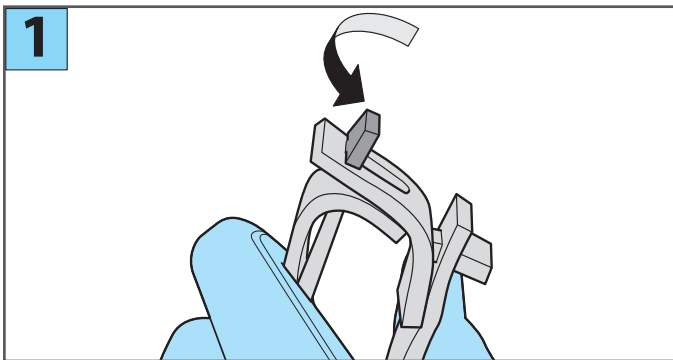

Lift the end of the highlighted link.

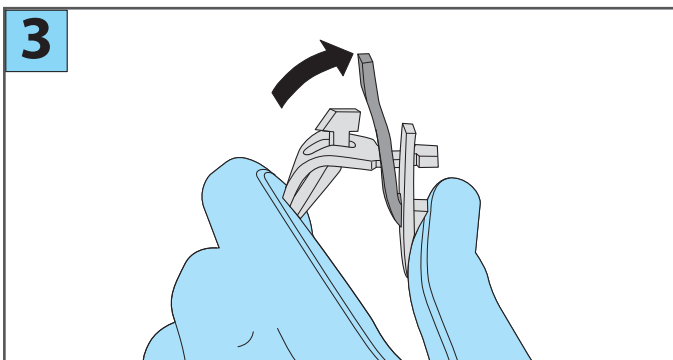

Then rotate the link and tab as shown.

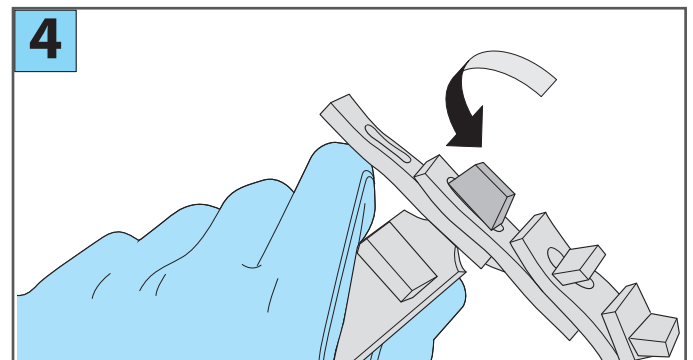

At this point it will be possible to remove the link.

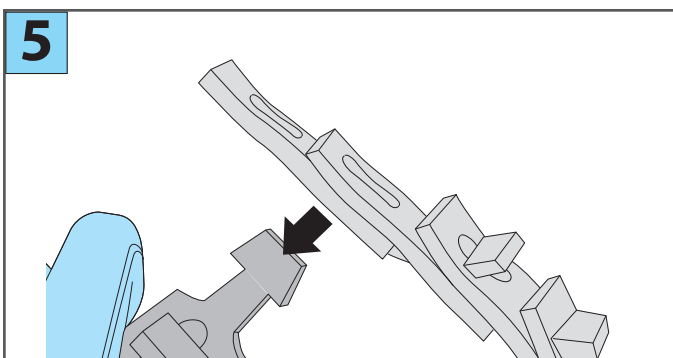



## Mesh connection



For easier connection of the links, it is advisable to rotate the belt 180° as illustrated below.

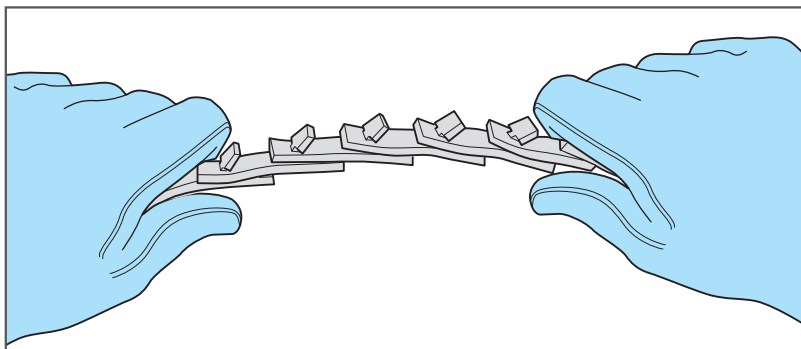

Insert the tab into the two overlapping links as shown.

Then rotate the link and tab as shown.

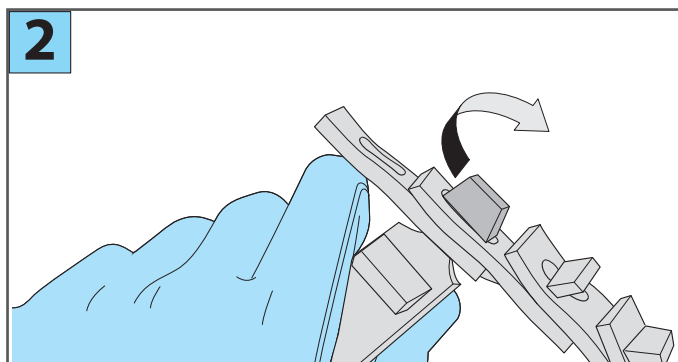
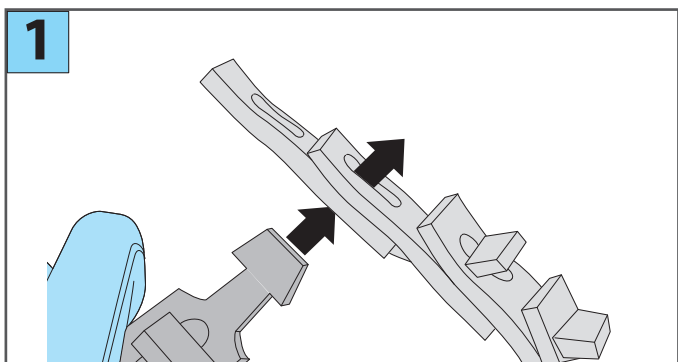

Grasping the belt with one hand, take the highlighted link and insert it into the tab below.

Then rotate the tab as shown.

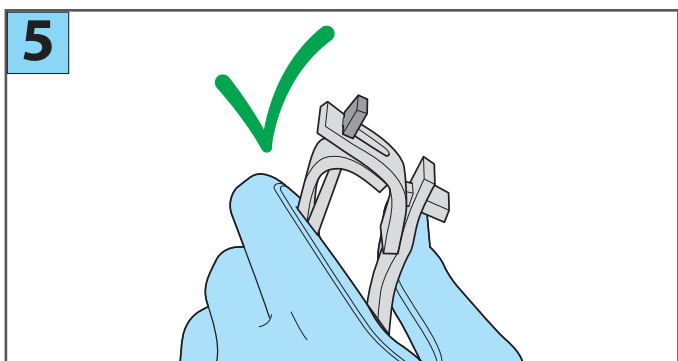
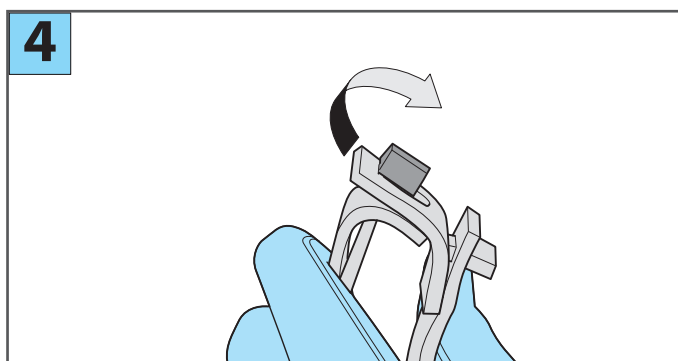
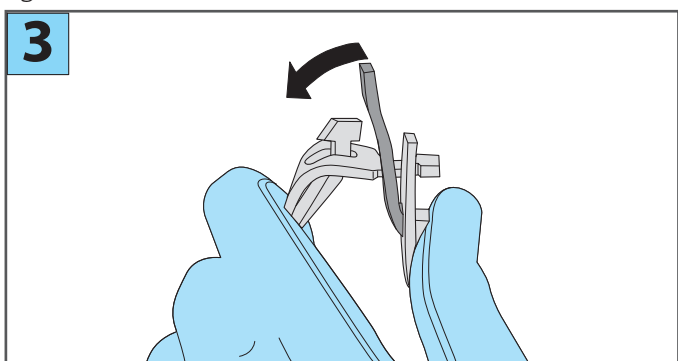

## Installation

1. Before proceeding with the installation, turn the belt so that the tabs are inside
2. Identify the direction of rotation of the transmission

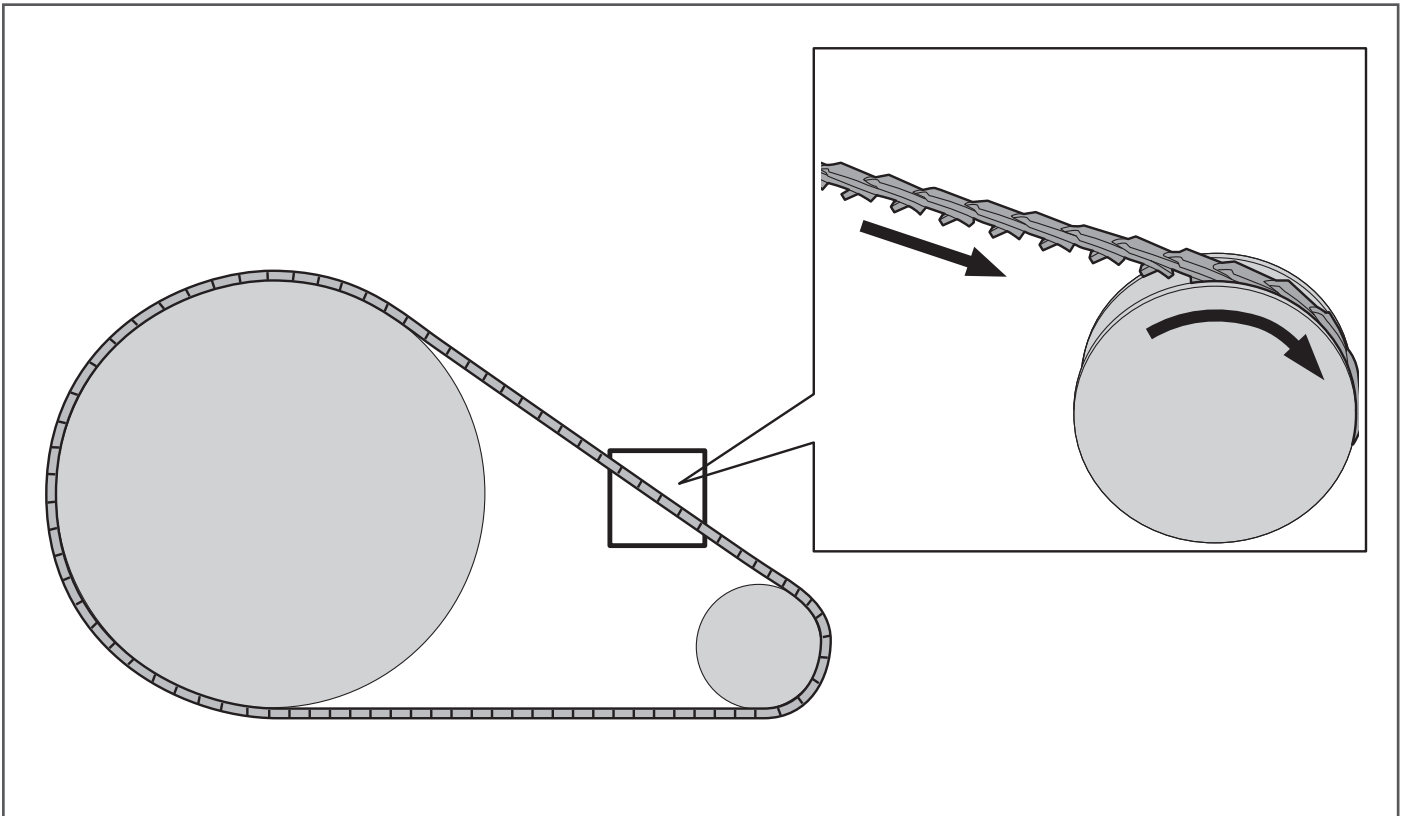

3. The belt should turn with the anchors following the direction of the arrow.

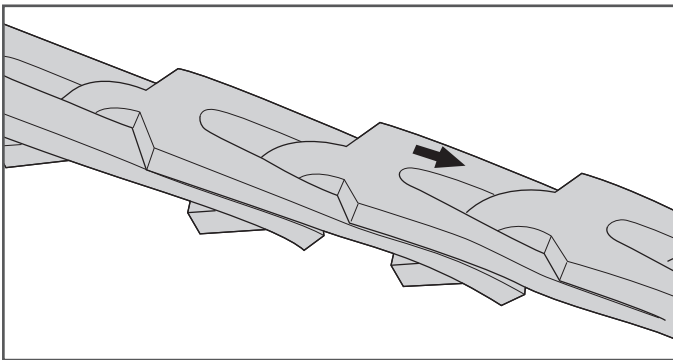

4. Insert the belt into the nearest groove of the smaller pulley.
5. Wind the belt onto the largest pulley slowly rotating the transmission. The belt can also feel very tight, but this is not a problem.
6. Check that all tabs are always in the correct position and are not misaligned.

## Tension adjustment

For the PowerTwist belt to work efficiently, the drive tension must be kept within the correct limits. Check the transmission tension between 30 minutes and 24 hours of full operation.



Check the belt tension periodically and adjust as needed.

Once the operations to set up the machine after installation have been carried out, it is possible to proceed with the commissioning of the machine.

To avoid damaging the machine, make sure that the machine's dampers are in the correct position. If the machine has motorized dampers and their opening is automatic and managed by the control unit on the control panel, check that they open.



**To perform the activities listed in this chapter 7, the Personal Protective Equipment listed in chapter 1 is required.**

## Rotary heat exchanger alignment adjustment

**Instructions valid for Recuperator products.**

**There are no wheel adjustment devices for Hoval recuperators.**

### Wheel alignment

Visually check whether, after having isolated the motor electrically, turning the heat exchanger by hand, it exhibits any lateral movement.

The tilt of the rotor can be adjusted through the screws on each side.

**- For rotors between Ø 500 mm and Ø 1350 mm**





1) Loosen the 4 screws (photo A)



2) Adjust the toe-in of the wheel using the vertical bolt (photo B)



1) Loosen the two screws (photo C)

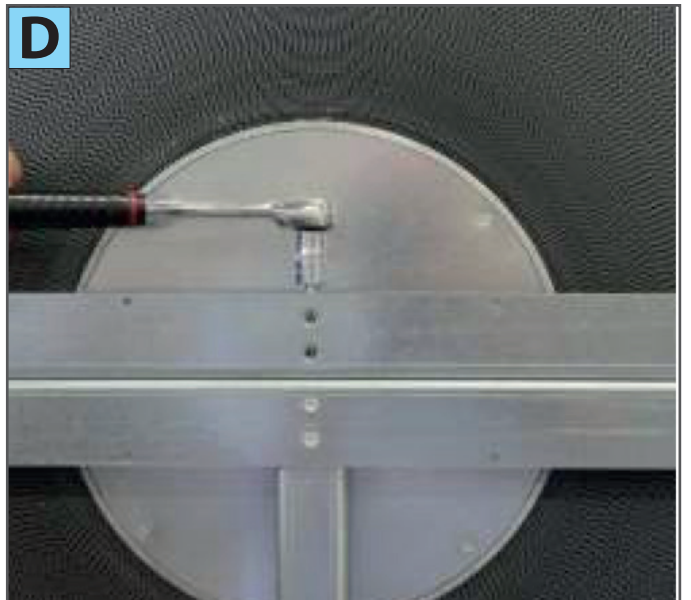

2) Adjust the toe-in of the wheel using the vertical screw (photo D)

- For rotors between Ø2000 and Ø 2400 mm

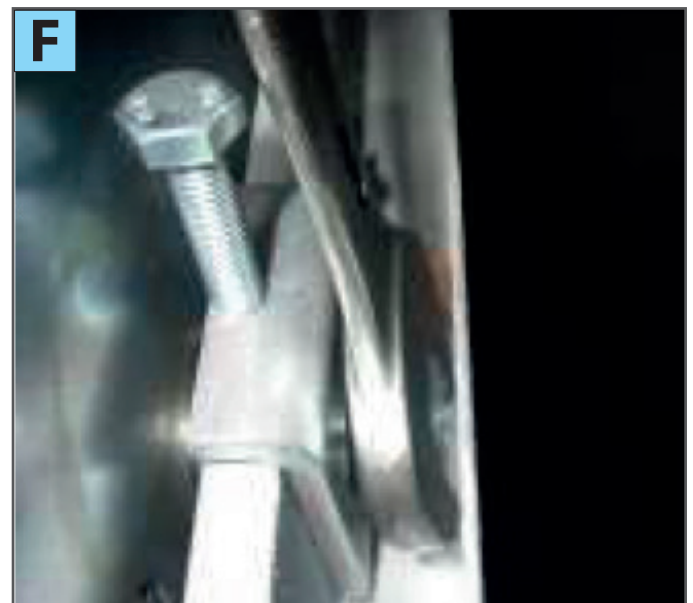
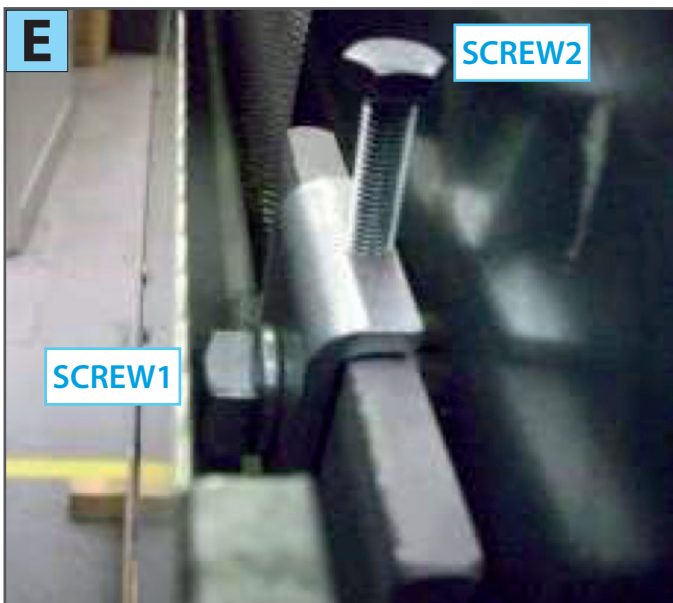

1) The two adjustment screws are located in the centre of the rotor (photo E)

2) Loosen screw 1 (photo F)



3) Adjust the toe-in of the wheel through bolt 2 (photo G)



4) Tighten bolt 1 (photo H)

5) Check the bolt on the opposite side is tight

At the end of the adjustment, the distance between the wheel and the frame must be  $15 \pm 5$  mm on both sides.

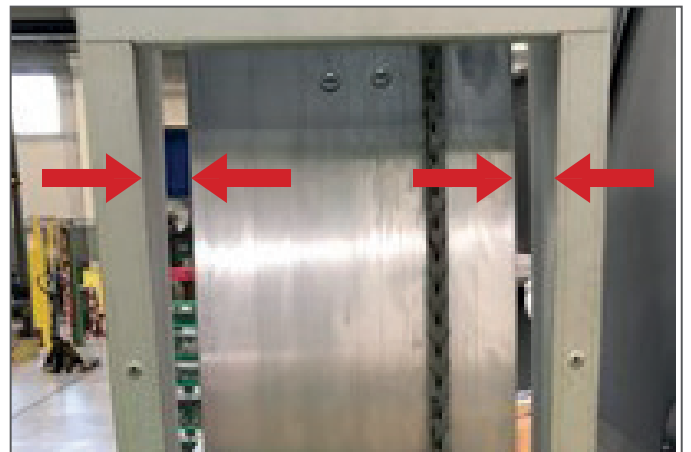

## Step 4: Make the connections

To operate the machine requires:

- An electrical connection.
- A water connection and drainage.
- A connection to the aeraulic circuit (air ducts).

### Electrical connections

As to the **power supply**, an **electrical cable** must be connected to the machine:

**single phase + neutral + earth** (size 01 and 02).

**three phases + neutral+ earth** (size from 03 to 10);

(N.B.: The power supply of any electric batteries is separate from that of the unit and is always three-phase).

The cable must have a **section adequate to the electrical** absorption of the machine and the current regulations. The total electric draw is shown on the machine's tag.



**Always refer to the wiring diagram that is specific to the machine that you bought** (it was shipped with the unit). If it is not on the machine or has been lost, contact the salesperson of reference who will send a copy (specify the machine's serial number).

Before connecting the machine make sure that:

- The voltage and frequency of the power supply correspond to the parameters of the machine.
- The electrical system being connected has sufficient capacity to supply the nominal electric power of the machine to be installed and meets current regulations.



The electrical connection must be:

- Performed by qualified personnel after cutting off the facility's power supply.
- Performed in a fixed and permanent manner, without intermediate splices, in accordance with the regulations of the country of installation.
- The power supply is sufficient for the machine (see technical specifications).
- Includes a functioning grounded plug; for multiple units it is necessary to combine them all with metal ties.
- Preferably situated in a dedicated room, **locked**, and protected from atmospheric agents. If there is also a key switch, the key must be removed when cutting the power supply and returned to its position only after finishing service operations.
- Controlled by a **multipolar switch** with switching capacity equal to 60A suitable for the machine absorption.



During installation and maintenance, make sure that **no other person** besides the one who is working has access to the electrical cabinets or switches.



The actual supply voltage of the user devices **must not deviate more than 10%** from the expected nominal voltage. Higher voltage differences cause damage to users and to the electrical system, malfunctioning of fans, noise. It is therefore essential to check the alignment of the actual voltage values with the nominal values.



The Manufacturer is not responsible for connections made in a manner that does not comply with regulations, with the specifications of this manual, and in the event of tampering with any electrical component of the machine.

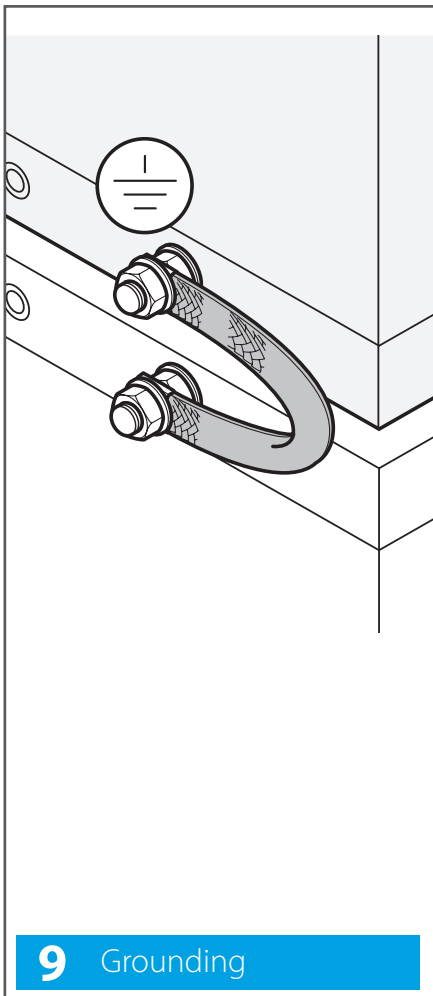

**9** Grounding

Size 01 ÷ 02  
supply 230/1/50 (V-F-Hz)

Size 03 ÷ 10  
supply 400/3/50 (V-F-Hz)

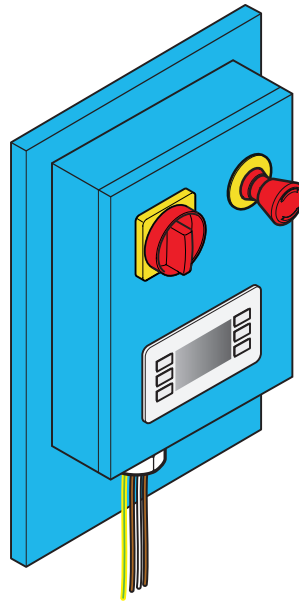

NB: Electric battery module power supply always 400/3/50 (V-F-Hz) separate from that of the unit.

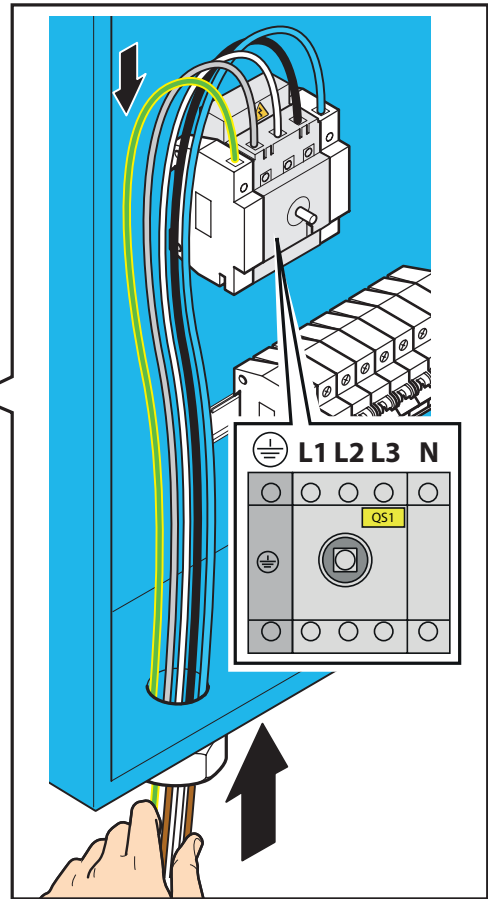

**10** Example of electrical connection



**Additional warnings regarding the connection to the power supply:**

It is necessary to install a suitable differential-type protection upstream of the machine's power supply connection points, in order to be able to isolate each of its elements in the event of malfunctions; the choice of the differential protection device must not be in conflict with the provisions of the law, the local regulations, the characteristics of the plant's electrical system and of the machine itself.

They are recommended, where not in contrast with local laws or system characteristics, differential switches with adjustable current and trip time that cannot be affected by high frequency. The cables connecting the various elements of the machine to the power supply must be shielded or must pass through metal ducting, so as to reduce electromagnetic interference.

The shield or metal ducting must be earthed.

Once the system has been set up, the machine can be connected to the electricity supply network. The actual supply voltage of the user devices must not deviate more than 10% from the expected normal voltage. Higher voltage differences cause damage to users and to the electrical system, malfunctioning of fans, noise. It is therefore essential to check the compliance of the actual voltage values with the nominal values.

Before connecting the electrical panel, make sure that, during installation and maintenance, no other person besides the one who is working has access to the electrical cabinets or switches.

After connecting, make sure that:

- The ground connection is sufficient (using the appropriate tool). An incorrect connection, ineffective and lacking the grounding circuit, is contrary to safety regulations and is a source of danger that can damage the components of the machine.
- The connections are correct, and the current consumption of the motor is lower than indicated on the nameplate.



## Water or coolant gas connections

Connections to water or to a coolant gas are required for the installation of a water or direct expansion coil (optional).

For the **water/gas supply** it is necessary to connect the manifolds to **pipework having a size that is sufficient for the flow rates envisaged**: in order to avoid damage to the heat exchange battery in correspondence with the junction between the steel fluid supply manifold and the copper circuits, it is necessary, when fixing the system pipe, to use a double wrench so as not to overload the battery connections.

To ensure optimum heat exchange of the coils it is necessary to:

- WASH them prior to connecting them to the network.
- Completely eliminate the air present in the water circuit using suitable valves.



**To avoid damage to the battery, caused by ice, it is advisable to fill the water circuit with antifreeze liquid or completely empty the battery if the air temperature can drop below 3°C.**

Apart from the heat transfer fluid used, the thermal exchange with the air occurs in flow, with counter flow injection with respect to the flow of the treated air. Connect the pipes following the indications of the plates placed on the machine's panel.



**Take care that no moisture or dirt enters the heat exchange coil.**

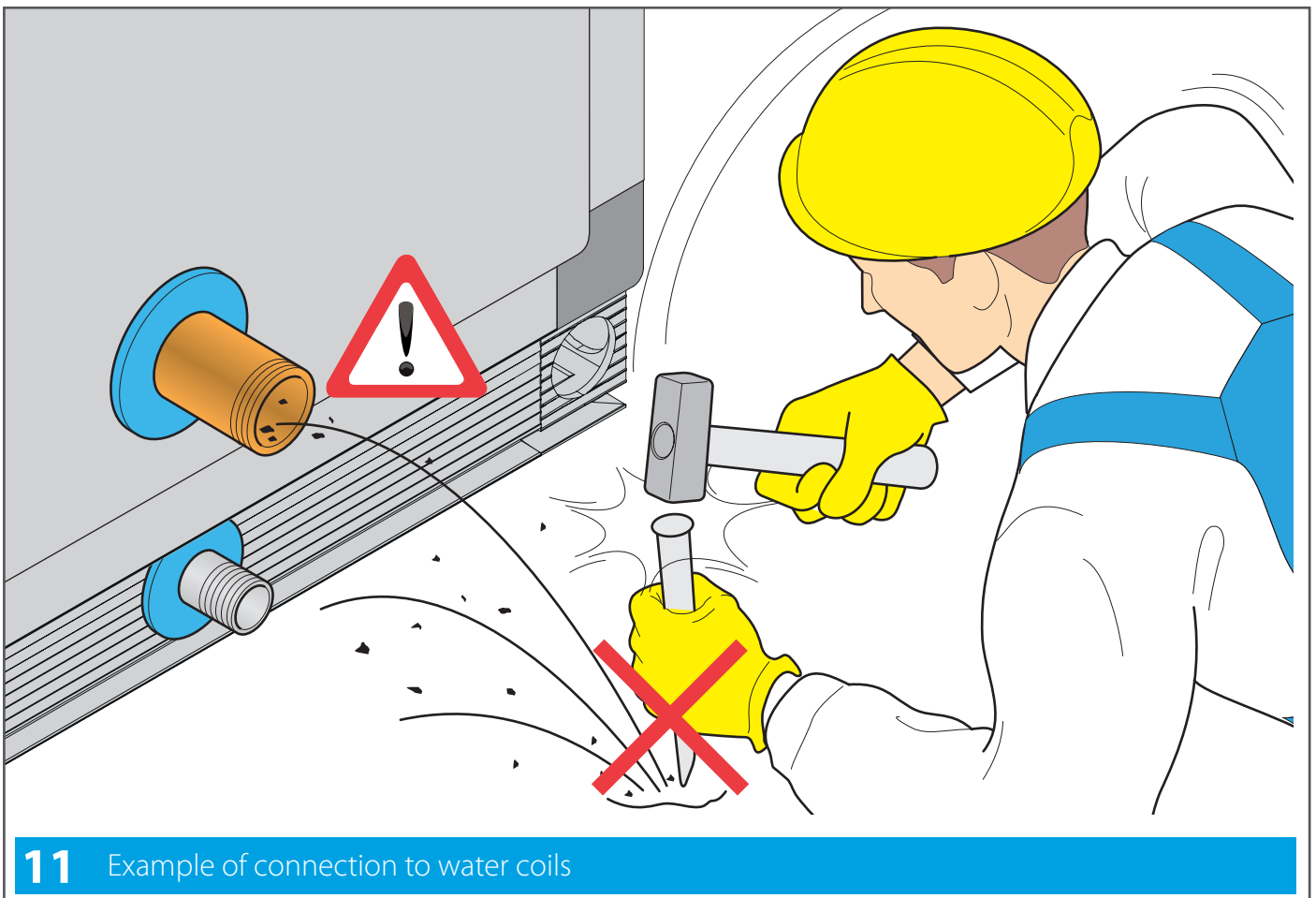

**11** Example of connection to water coils

## WATER-BASED THERMAL EXCHANGE COILS

The heat exchange coils are installed with horizontal pipes.

The circuit pipes must have a size based on the nominal flow rate calculated from the thermal output of the project and indicated in the data sheet of the unit.



Do not use the heat exchange coil connections to support the weight of the piping. It is necessary to prepare appropriate fasteners and brackets (not supplied).



**Shut-off valves** must be included to exclude the heat exchange coil from the water circuit.

In the heating coils, a stopped fan could lead to the overheating of the stagnant air in the machine, with possible consequential damage to the motor, bearings, insulation, and parts made of synthetic material. To avoid such eventualities, it is advisable to design the system so that a stopped fan will also stop the passage of the heat transfer fluid.

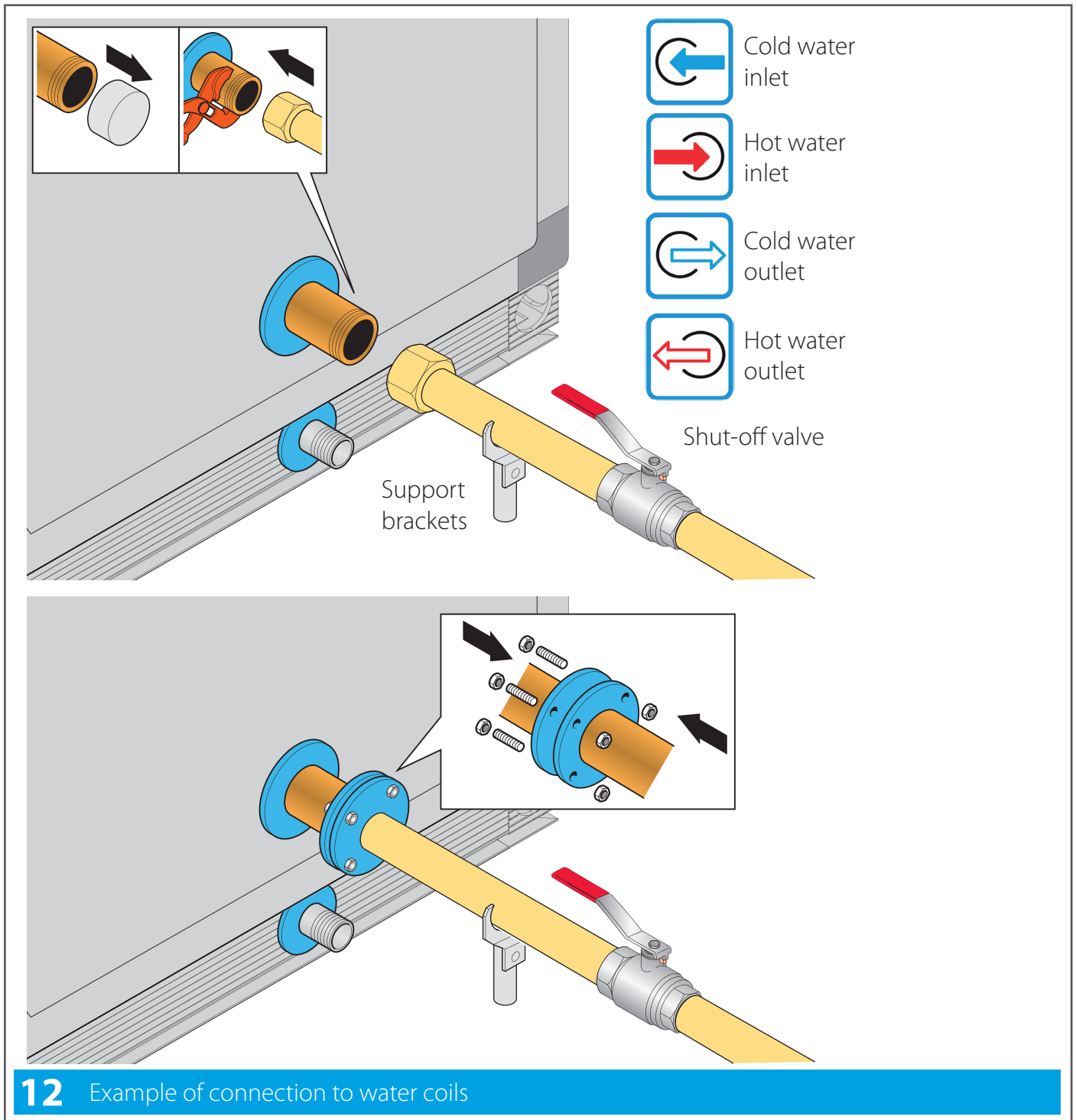

**12** Example of connection to water coils

## DIRECT EXPANSION THERMAL EXCHANGE COILS



The filling by the installer must be performed according to current regulations and by authorized personnel, authorized for the use and handling of coolants. The heat exchange coils are installed with horizontal pipes.



Do not use the heat exchange coil connections to support the weight of the piping. It is necessary to prepare appropriate fasteners and brackets (not supplied).



**Shut-off valves** must be included to exclude the heat exchange coil from the coolant circuit.

The system piping must be connected to the heat exchange battery with braze welding, circulating **anhydrous nitrogen** inside the pipes to prevent oxides from forming. The liquid suction pipes must be the appropriate size for the expected potential and to ensure the circulation of the oil present in the coolant even when the heat exchange coil operates at minimum load.



Use of wet patches to protect the plastic against the heat of the flame.

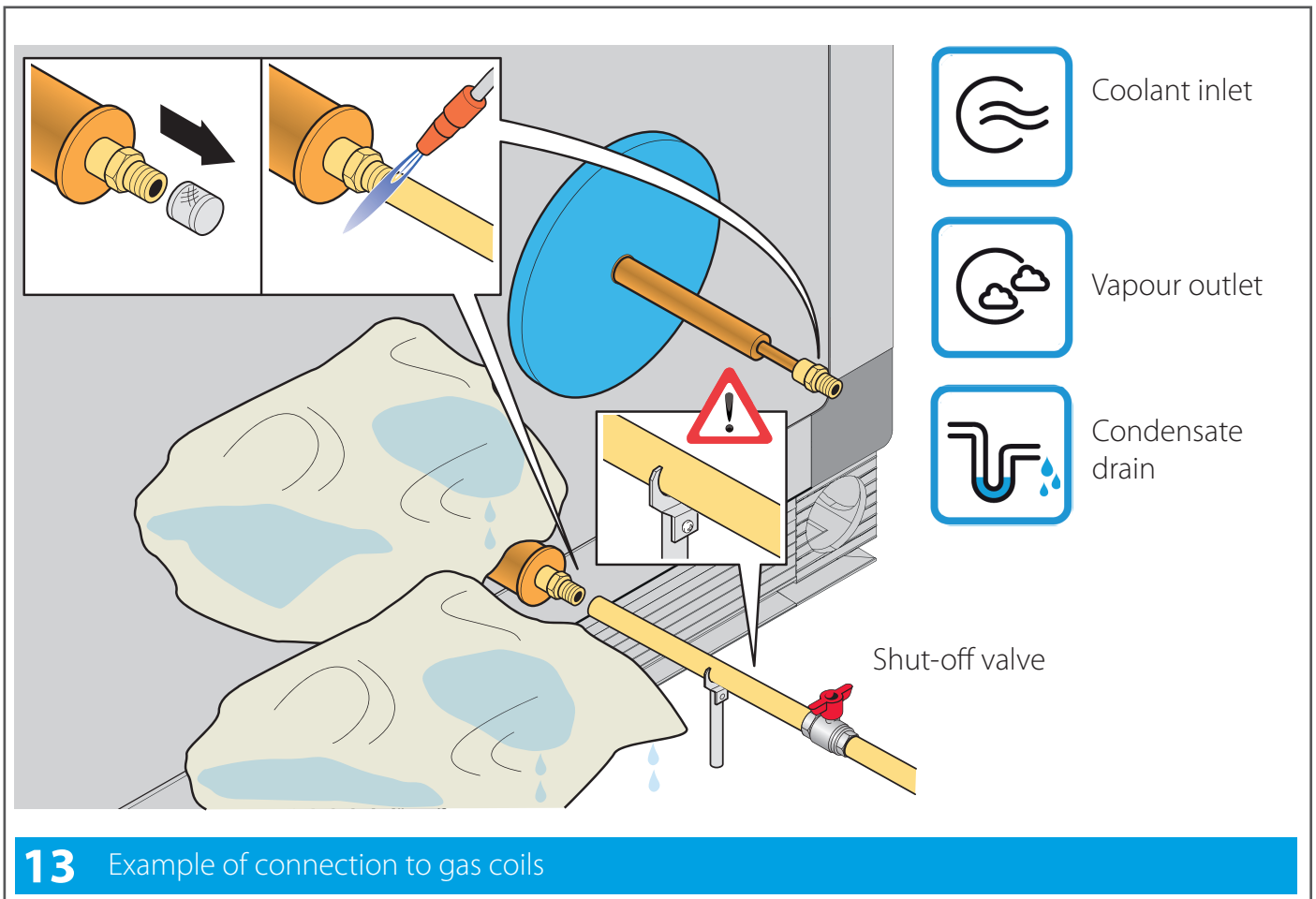

## Drain and siphon

In correspondence with the humidification sections and the thermal exchange cooling coils, the air handling units are equipped with a threaded drain that **protrudes laterally for about 80 mm**.

In order to allow a regular flow of water, each drain must be fitted with a properly sized SIPHON (see fig. 14).

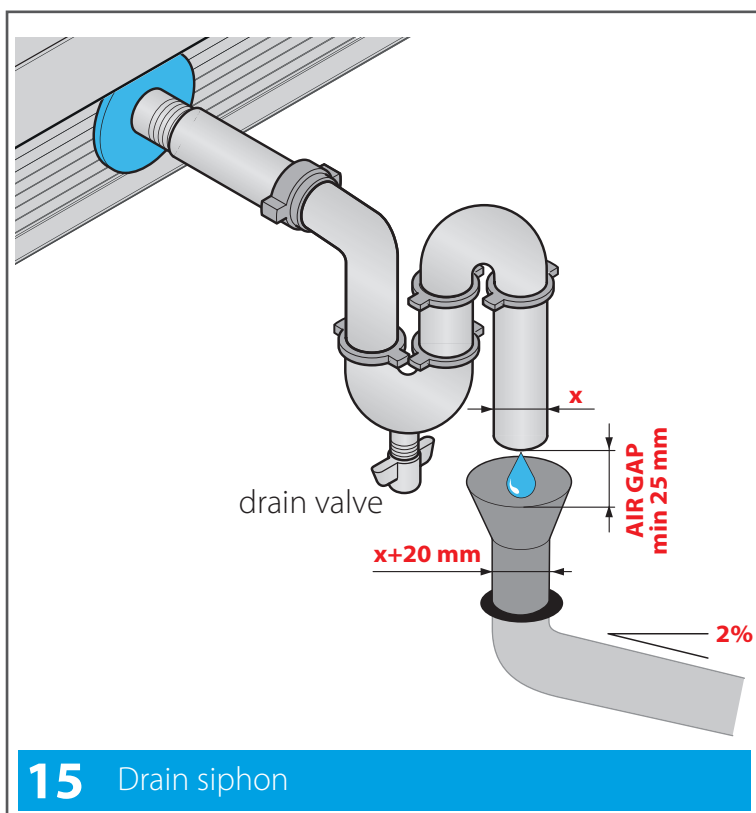
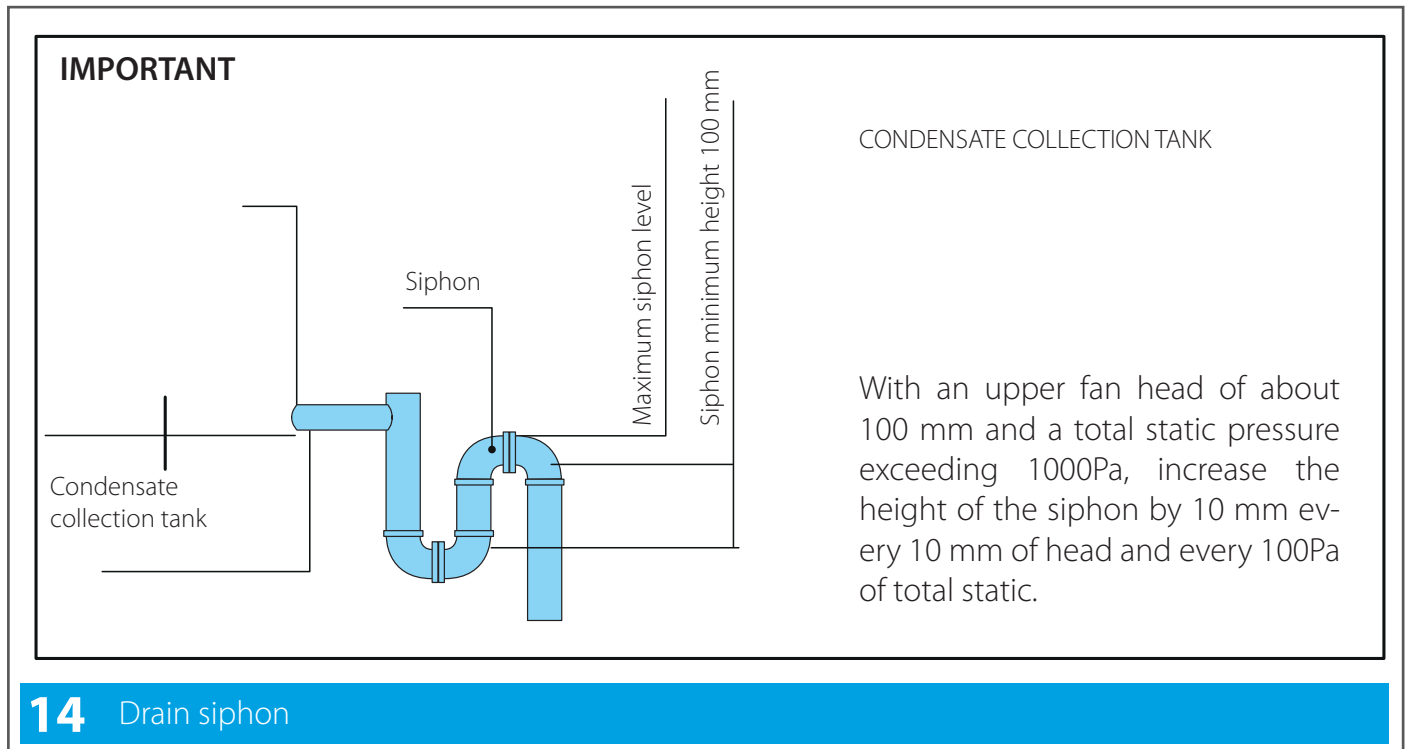

To avoid overflows from the collection tank and consequent flooding of the machine as well as the room in which it is installed, the siphon must have a **purge valve** that allows the removal of impurities deposited on the bottom.

In order not to affect the operation of the drainage system, siphons operating under pressure must NOT be connected to others operating under vacuum.

The drainage pipe to the sewerage network:

- **Must not be connected directly to the siphon.** This in order to absorb returns of air or slurry and to make the correct outflow of waste water visible.
- Must have a larger diameter at the machine drain and a minimum inclination of 2% in order to ensure proper operation.

## Aeraulic connections

If present, the air ducts must be connected to the joints or the circular attachments that may be provided on the unit. If these components were not provided with the machine, the coupling can be made by connecting directly to the machine's panels, making sure to insert a suitable anti-vibration system between the unit and the duct.

If not using anti-vibration joints, it is necessary to:

- Clean the joint surfaces between the duct and the machine/coil.
- Apply a gasket to the flange to prevent air infiltration.
- Carefully tighten the connecting screws.
- Use silicone on the gasket to optimise the seal.

If the connection is made with anti-vibration joints, when assembly is complete, they should not be taut, so as to avoid damage and the transmission of vibrations.

To ensure the seal of the connections and the integrity of the machine, it is essential that the air ducts be supported by special brackets that do not weigh directly on the machine.

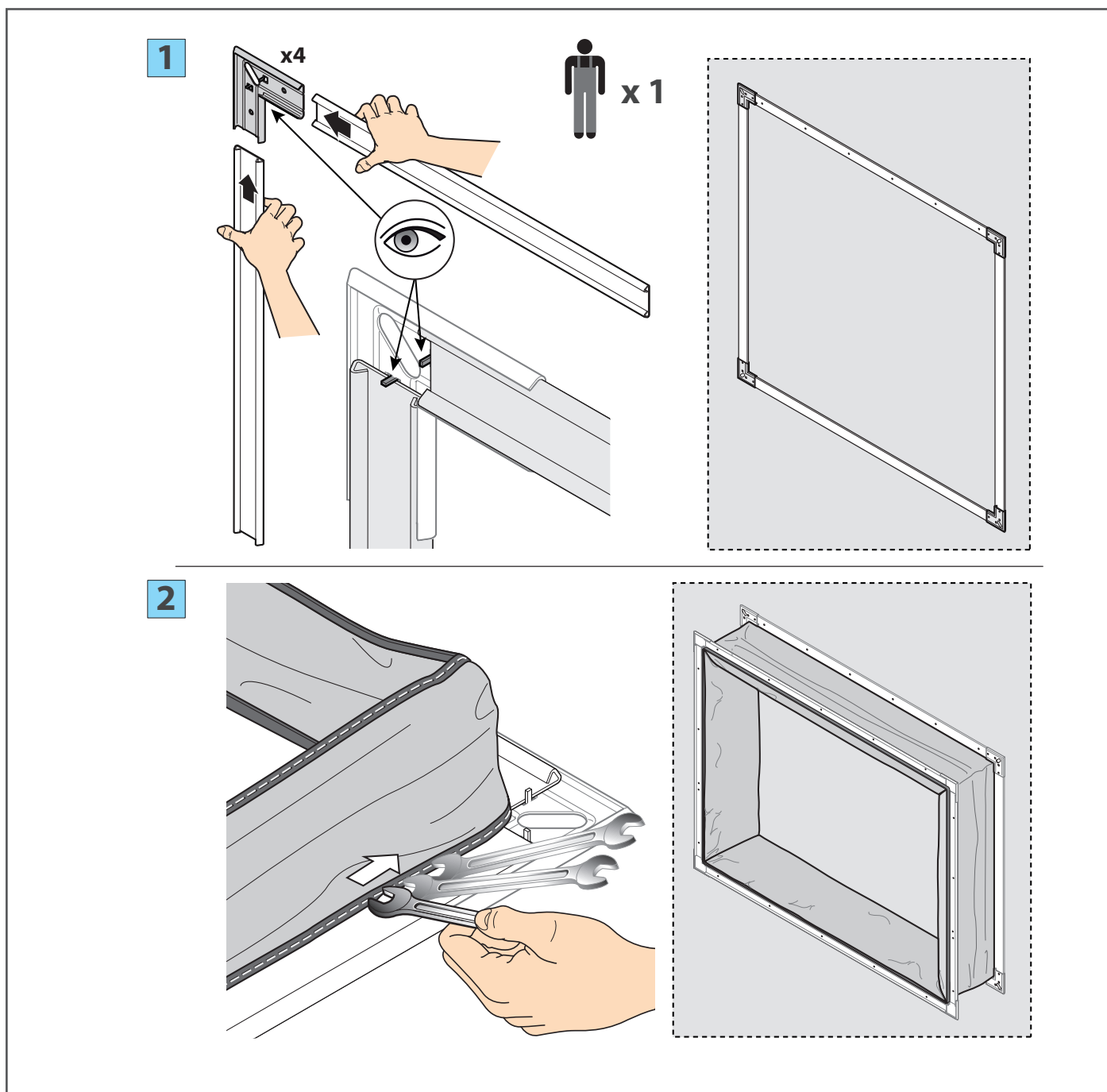

3

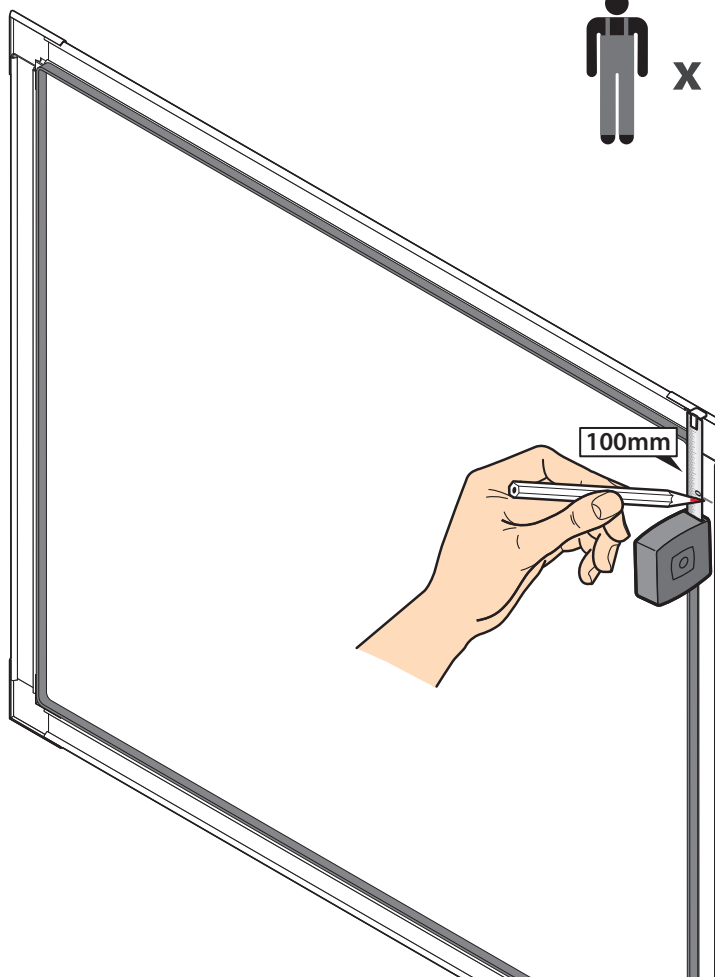
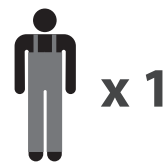
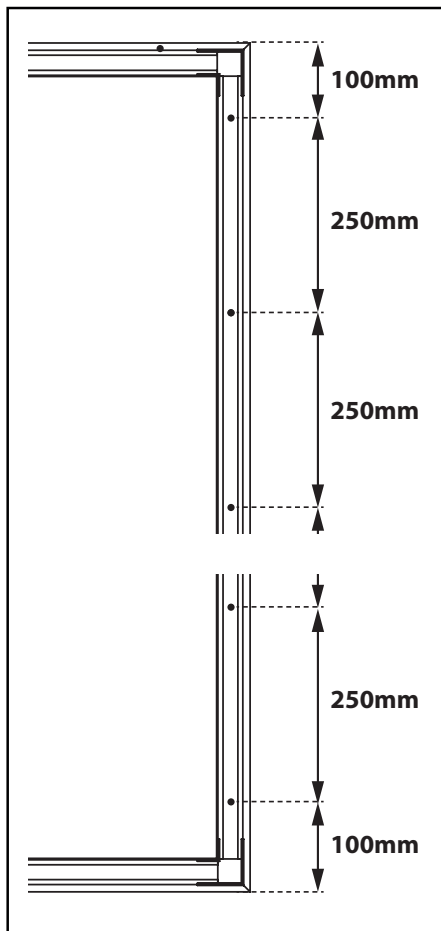

4

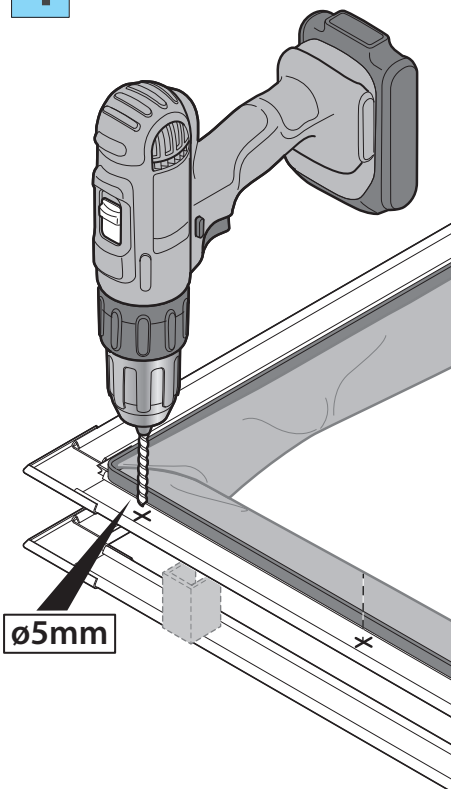

5

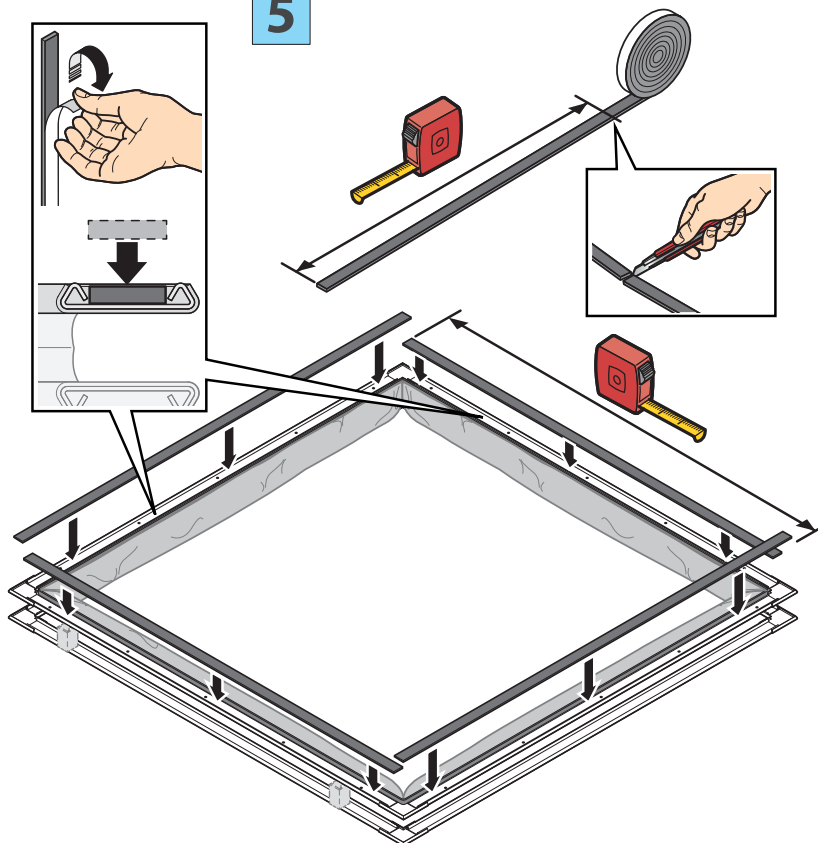

6

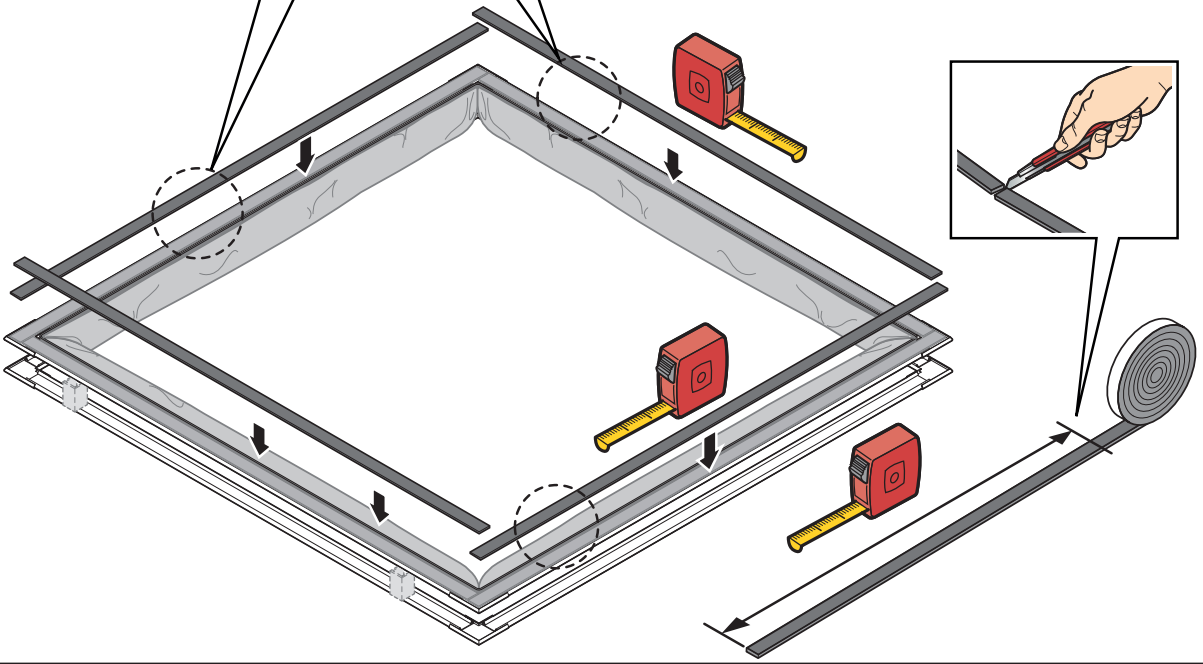
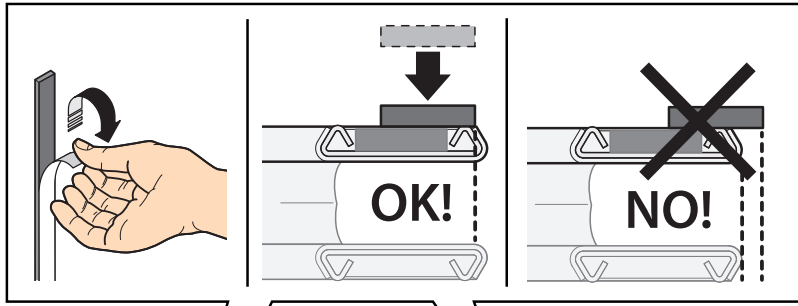

7

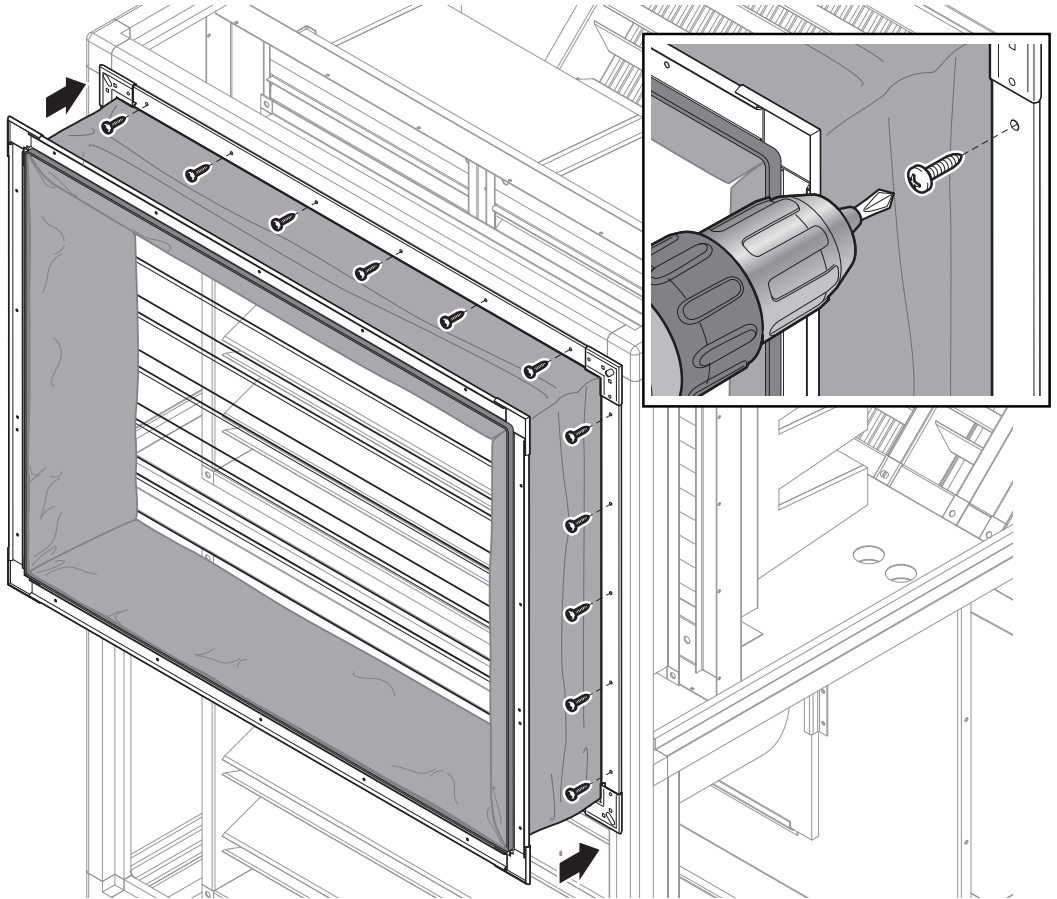

8

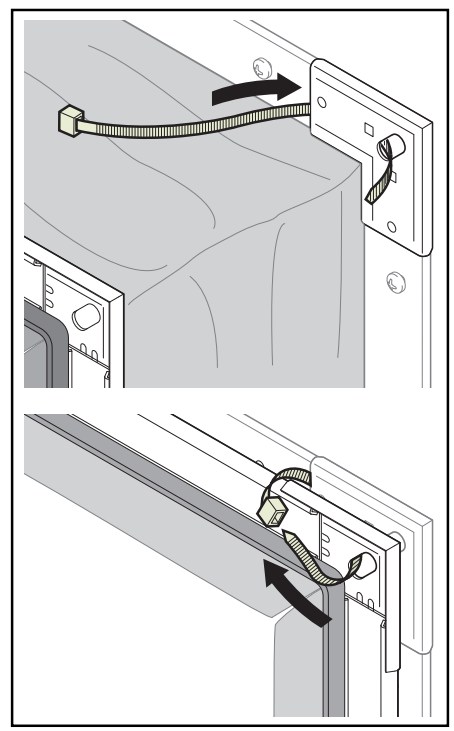
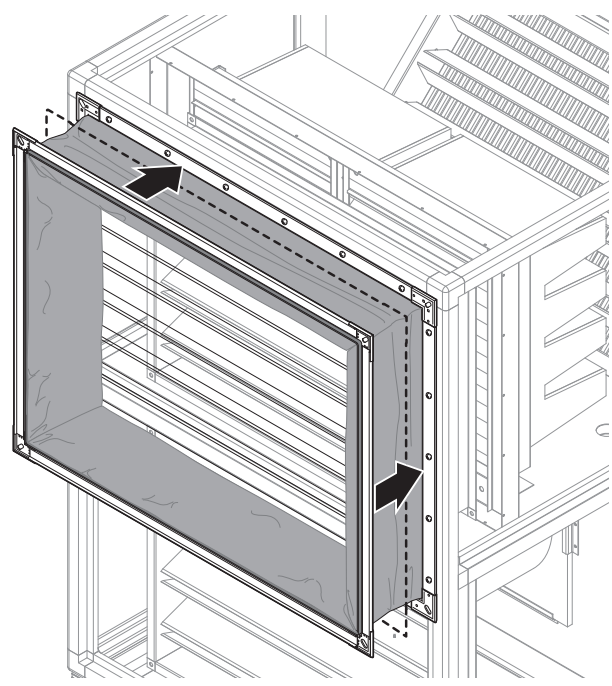
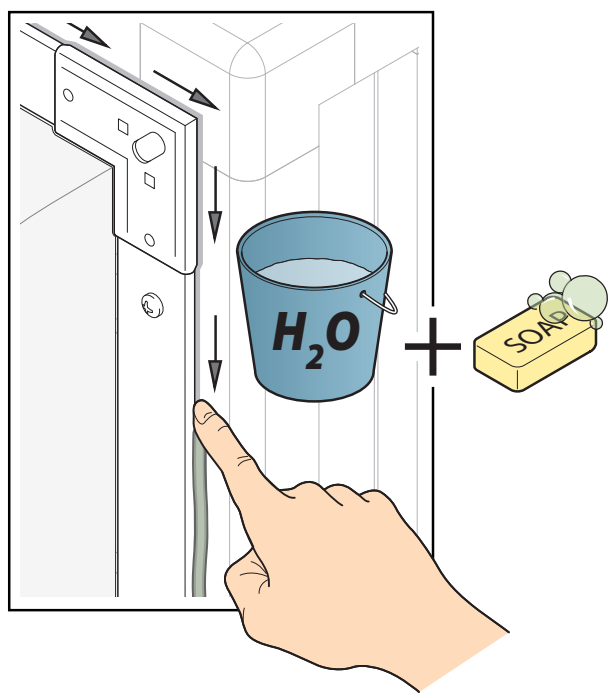
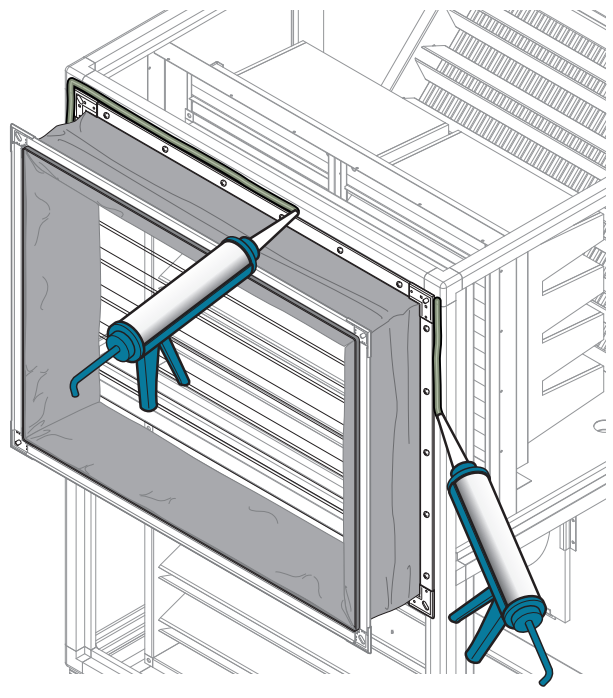



9

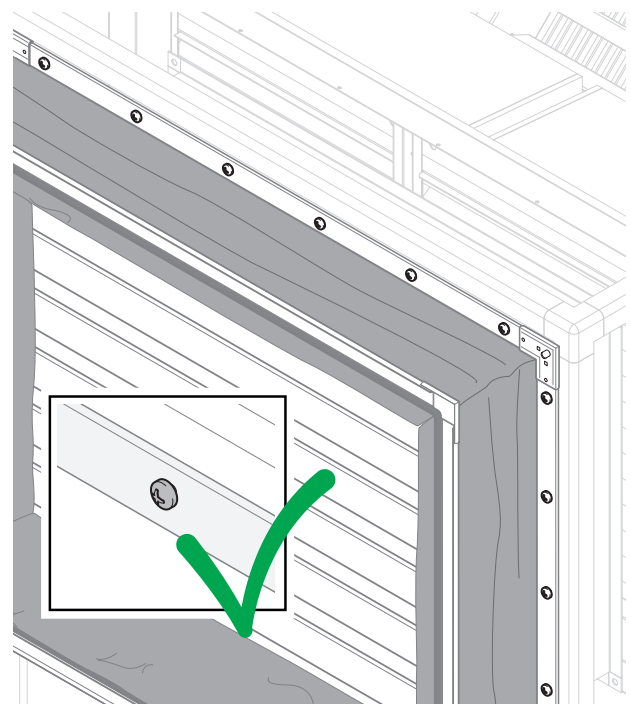
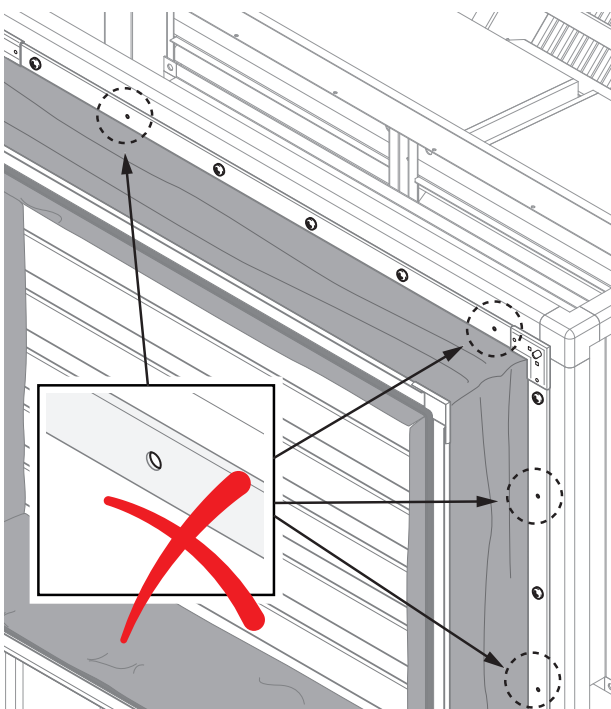
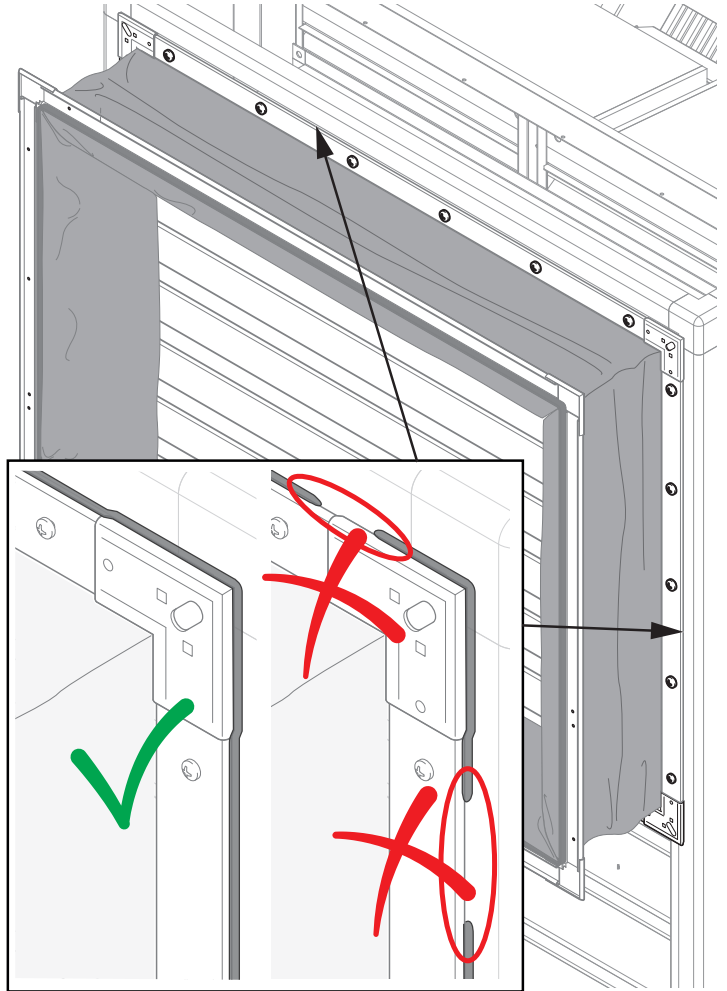
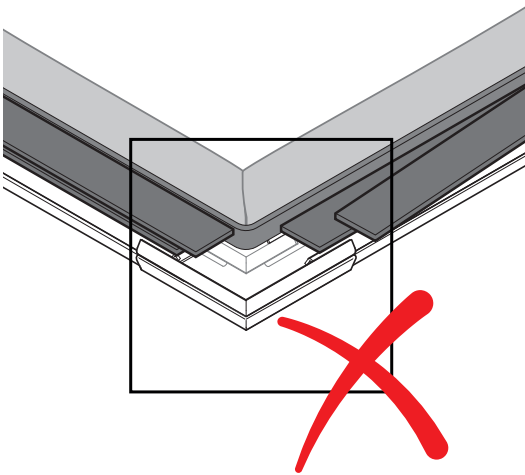
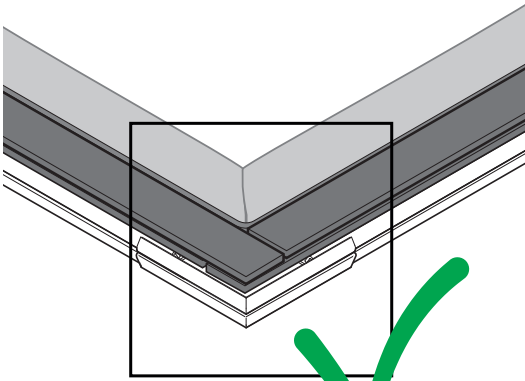

# Notes

---

---

---

---

---

---

---

---

---

---

---

---

---

---

---

---

---

---

---

---

---

---

---

---

---

## Step 5: Perform a trial run

To commission the machine, it is necessary (tick "✓" the operations completed):

	Check the proper connection of the fluid inlet and outlet piping to the thermal (if present) exchange coils (if present).
	Vent the air from the heat exchange coils.
	Check that there is a suitable siphon for all the water being drained.
	Inspect the correct installation and adequate electrical connection of the energy recovery equipment, together with a mechanical and electrical check.
	Insert an anti-vibration coupling between the machine and the ducts.
	Check the tightening of screws and bolts (especially those used to attach motors and fans).
	Check the integrity of the anti-vibration supports and the various accessories.
	Remove extraneous materials (e.g., assembly sheets, tools, clips, etc.) and dirt (footprints, dust, etc.) from inside the sections.

## Step 6: Install the required filters

Verify proper installation of the prefilters located on special counter-frames with safety springs or guides. After removing the filters from the packing (that they are placed in to prevent deterioration during transport and at the installation site), insert them into the containment section, paying attention to ensure a rigid assembly and a perfect seal of the gaskets.



Remove the filters from their packaging only when ready to install them to avoid getting them dirty and contaminating them.



Make sure that the inside of the filter is not contaminated by external agents.

This operation should be carried out after the first start-up of the machine, when the ducts are cleaned of dust and various debris. Proceeding in this way preserves the filtering sections that cannot be regenerated.

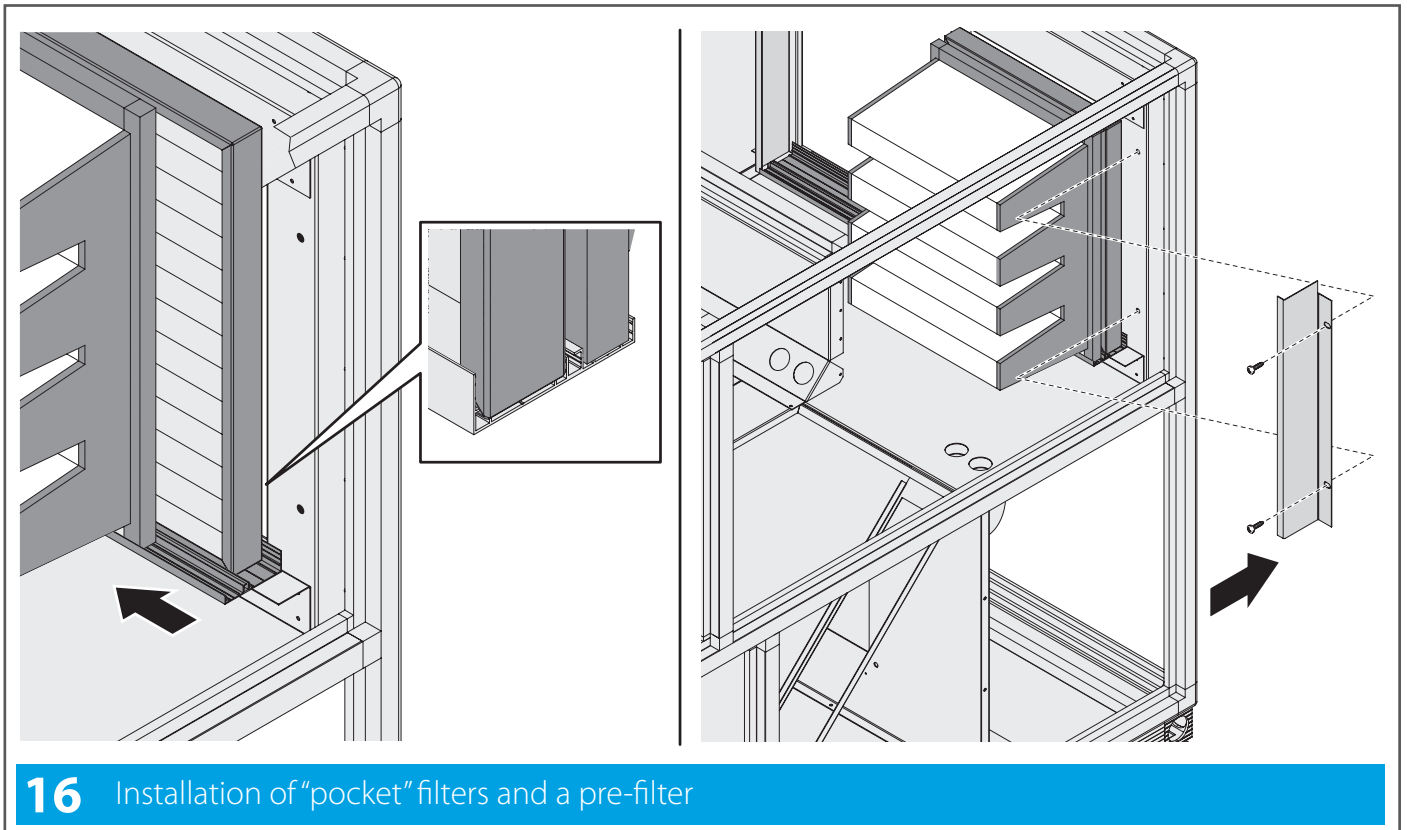

### 16 Installation of "pocket" filters and a pre-filter



To protect the components installed inside the unit, make sure that coarse filters (Prefilters) are installed.

## Step 7: Safety signs

The machine is supplied with the electricity-specific signs on the access doors to the fan sections.

The buyer must position other appropriate signs in the work area:



**DO NOT REMOVE THE PROTECTIONS AND SAFETY DEVICES**

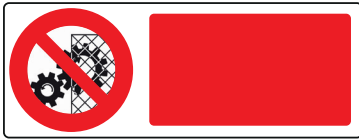

**DO NOT REPAIR - OIL - ADJUST - CLEAN MOVING PARTS**

In addition, the space where the machine is positioned must be integrated into the general signage, specific to the characteristics of the area and workplaces:

**noise - movement - dangerous areas - escape route, etc.**

### PERSONAL PROTECTIVE EQUIPMENT



Personal protective equipment should be used when operating the machine, suitable for use in accordance with company criteria and rules.

During machine maintenance, other preventive measures are suggested in addition to the above: safety shoes, gloves, suitable clothing, always compatible with the use and according to company guidelines.

### TRAINING

It is the responsibility of the machine buyer/user to provide adequate instruction and training to machine operators.

### OPTIONAL

In agreed cases, additional training may be provided through the one-on-one instruction of operators by the Manufacturer's technical staff.

# 7 Commissioning

After carrying out the above-mentioned connections, it is necessary to set up the machine, according to the following:

- Check that the batteries are correctly supplied (input / output).
- Ensure that all batteries are vented.
- Check that the drains are made and connected correctly, checking the correct flow of the condensate.
- Make the siphons and trigger them.
- Provide an anti-vibration joint between the ducts and the machine.
- Check the filters are installed correctly.
- Check the tightening of screws and bolts.
- Confirm that the structure is earthed.
- Confirm that the belt is correctly tensioned (only Modular rotary recuperator).
- Check that the recuperator belt is correctly tensioned (only Modular Rotary).
- Check the dampers are working correctly.
- Check that all the electrical components, such as microswitches, disconnectors, lights, pressure switches, probes, inverters, etc. are correctly connected and powered.
- Remove any foreign materials from inside the machine.
- Check and keep the inside of the machine adequately clean.
- Remove the blocks of the rotary recuperators (Modular).
- Check the direction of rotation of the impeller for plug fan.
- Check the integrity of flexible joints and anti-vibration for size 5 to 10 modular units.

To perform the task in question, Personal Protective Equipment is required (for example, safety shoes, safety glasses, helmet, gloves, etc.)

Once the operations to set up the machine after installation have been carried out, it is possible to proceed with the commissioning of the machine.

To avoid damaging the machine, make sure that the machine's dampers are in the correct position.

Do not start the motor-fan units without first checking the completion of the machine connections with all the necessary ducts.

Check the correct installation of the prefilters.

After removing the filters from the packaging (they are placed in to prevent deterioration during transport), insert the absolute and active charcoal pocket filters into the containment section, paying attention to ensure a rigid assembly and a perfect seal of the gaskets.

To avoid damage to the battery, caused by ice, it is advisable to fill the water circuit with antifreeze liquid or completely empty the battery if the air temperature can drop below 3°C.

### Checking the machine safety devices

Checking the efficiency of the safety devices fitted on the machine **MUST** be carried out prior to commissioning.

#### Microswitch (optional)

Use the following procedure:

- Open one of the inspection doors fitted with a microswitch on the machine.
- Check it is impossible to start the machine itself.
- Close the door and open another door fitted with a microswitch. Repeat the operation for all interlocked inspection doors, checking each time that the machine cannot be started.
- Similarly, press the emergency button on the outside of the control panel and check that the machine cannot be started.

## Use of the machine

It is essential that any dampers on the system side are open for the correct operation of the machine and to avoid sure breaking phenomena, open the dampers before starting ventilation.

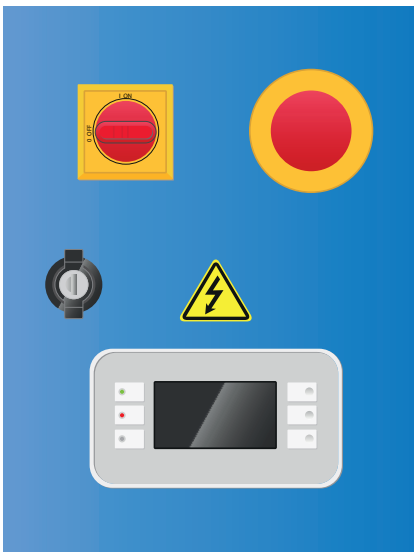

The sequence that leads to the automatic start-up of the machine is as follows:

- Power the machine by acting on the general disconnecter.
- Carry out the programming necessary for the correct operation of the machine.

The machine does not require further intervention by the operator as it has automated start-up and shut-down and is managed by the controller. If you want to permanently turn off the controller, you must turn off the automatic management and intervene at the disconnecter.

# 8 Maintenance

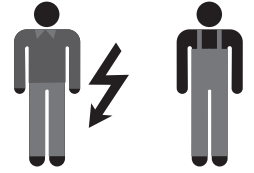

## Safety precautions for maintenance



Ordinary and extraordinary maintenance must be carried out **solely by the operator assigned to perform maintenance** (mechanical and electrical maintenance staff) according to the regulations in force in the country of use and respecting the laws regarding systems and work safety. Remember that, by operator assigned to perform maintenance is meant the person who can work on the machine to perform ordinary and extraordinary maintenance, repairs, and fine tuning. This person must be an expert operator, properly instructed and trained, given the risks involved in such operations.



Before performing any ordinary and extraordinary maintenance, the machine **must always be stopped (by disconnecting it from the mains)** turning the master switch OFF. The switch must have a key that must be removed and held by the operator who will perform the operations until the end of the maintenance itself.



**It is absolutely prohibited to remove any protections** from moving parts and unit protection devices with the machine connected to the mains or operational. Adjustments made with safety devices disengaged must be performed **by a single person**, expert and authorized, and during this activity it is necessary to prevent access to the area of the machine by other people. Upon completing the adjustments with safety devices disengaged, the protections must be re-engaged as soon as possible.



During maintenance the operational space surrounding the machine for a distance of 1.5 metres must be free of obstacles, clean and well lit. It is prohibited for unqualified people to pass through or remain in this space.



Use personal protective clothing (safety shoes, safety glasses, gloves, etc.) compliant with regulations.



Before carrying out repairs or other work on the machine, **always declare out loud** your intentions to other operators who are located in the machine area and make sure that they have heard and understood the warning.



When carrying out maintenance operations with the doors open, **never enter the machine, and close the access doors behind you.**





# Ordinary maintenance

Proper maintenance of the systems maintains efficiency (reducing costs) and consistent performance over time, and increase the usable life of the equipment.

ACTIVITY	FREQUENCY				
	A	B	C	D	E
General cleaning of the machine.		√			
Check and possible disassembly and washing of the filters to be inspected according to the conditions of use)					√
Replacing the filters (when they have deteriorated).		√			
Cleaning the finned surfaces of the heat exchange batteries (if provided) with a jet of compressed air or water and a soft brush (direction parallel to the fins).	√				
Cleaning the heat recuperator exchange surfaces with compressed air / water jet and a soft brush (direct / to exchange packs).	√				
Empty and clean the condensate collection basins.		√			
Visual inspection for corrosion, limescale, release of fibrous substances, any damage, abnormal vibrations, etc. (if possible, it is advisable to extract the components for a more thorough inspection).					√
Check condensate drain and cleaning of siphons.		√			
Check the status of anti-vibration connections.	√				
Check tightness of screws and bolts in the fan section.	√				
Check the impeller and various devices, with removal of any build-up.	√				
Check the integrity of piping connected to pressure gauges and pressure switches.					√
Check and fine tune servo controls and lifting assemblies for actuating the gripping dampers, and their lubrication.		√			
Check the ground connection.		√			
Visual check on the wheel face for dirt or deposits of dust and debris (Modular R)		√			
check of the condition of the transmission belt for wear and wheel tension (Modular R)		√			
Check the clearance between seals and rotor by visual inspection and, if necessary, correct it		√			
Check and cleaning (if necessary) of the recuperator exchanger pack (Modular P)			√		
Check the SPZ / SPA / Power Twist Belt tensioning of the rotary heat exchanger, if present		√			
Check the integrity of flexible joints and anti-vibration for size 5 to 10 modular units	√				

**A: annual / B: six months / C: quarterly / D: monthly / E: fortnightly**

## General information on cleaning procedures



Read the safety instructions at the beginning of this manual and page 64



You should consult with your supplier of chemical products to choose the most suitable for cleaning the unit components.



For the cleaning method refer to the instructions of the detergent manufacturer and carefully read the safety data sheet (SDS).

As general guidelines, refer to the following rules:

- Always use personal protection (safety shoes, safety glasses, gloves, etc.).
- Use mild products (pH between 8 and 9) for washing and disinfecting, in normal concentrations. Detergents must not be toxic, corrosive, flammable, or abrasive.
- Use a soft cloth or bristle brushes that do not damage the stainless-steel surfaces.
- If you use water jets, the pressure should be less than 1.5 bar and the temperature must not exceed 80°C.
- For cleaning components like motors, damper motors, bearings, pitot tubes, filters and electronic sensors (if applicable), do not spray water directly on them.
- After cleaning make sure that you have not damaged the electrical parts and the seals.
- Cleaning operations should not involve the lubricated parts, like rotation shafts, because this could affect their good operation and create problems with durability.
- For the cleaning of finned components or dampers use an industrial vacuum cleaner and/or a compressor. Attention, the compressed air flow must run opposite to the direction of the airflow through the unit and parallel to the fins.

### Cleaning filters



The machine must NOT be running when the filters are removed to avoid drawing in outside air that might be contaminated.

The filters must be cleaned often and carefully to prevent dust and microbial build-up. Usually, compact filters can be cleaned **two or three times** (replacement is anyway recommended in preference to washing) before they are replaced. As a rule, replacement is required after 500-2000 hours of operation (it varies depending on the type of filter, refer to the directions of the Manufacturer), but may need to be replaced much sooner if required.

**Compact filters** can be cleaned using a vacuum cleaner or by blowing with compressed air or hot water (not under pressure).

**Pocket filters** cannot be cleaned and must be changed after their life cycle.

### Cleaning lamellar components

Remove the dust and fibres with a soft bristle brush or a vacuum cleaner.



Be careful when cleaning with compressed air because the exchanger package can be damaged. Cleaning with pressure jets is allowed if the maximum water pressure is 3 bar and a flat nozzle is used (40° - WEG 40/04 type).

Oils, solvents, etc. can be removed with water or hot grease solvents, by washing or immersion. Periodically clean the condensate drain tray and fill the drain siphon with water.

## Dampers

Dampers and their mechanism can be cleaned first with compressed air, then with a slightly alkaline detergent. Particular attention should be paid to the levers of the actuation system.

Seals should be checked at regular intervals.

Also check if there is good rotation of the fins and the lubrication of the mechanisms. If necessary, use molybdenum disulphide oil in a spray as it is possible to direct the flow where it is needed.

## Exchange coils

**The coils must be cleaned at the slightest sign of contamination.**

The coil should be cleaned and washed gently to avoid damaging the fins.

For cleaning using a **mild detergent** suitable for the purpose. Do not use alkaline, acidic, or chlorine-based solutions.

The coils can be washed with a slightly pressurised water jet (max. 1.5 bar). The jet must NOT contain chemicals or microorganisms. Moreover, the water must be sprayed in the opposite direction to the air flow and parallel to the fins.

For the direct expansion system, all the coolant in the batteries must be collected in the receiver before washing the coil with water. This makes it possible to avoid the increase of the pressure and damage to various parts of the pipe, keeping the airflow clean.

Alternatively, it is possible to remove the batteries from the unit during cleaning. Avoid exposing them to the light and keep them in the dark.

For the cleaning of the injection tubes, you can access the distributor by removing the protective metal foil. Clean it with a soft brush and water, or if it is very dirty use a disinfectant diluted in water.

## Fans

The fans can be cleaned with compressed air or by brushing them with soap and water or with a mild detergent.

Finish cleaning by rotating the impeller by hand to check there are no abnormal noises.

## Vents

Periodically check that there are no new sources of contamination near the air intake. Each component must be checked periodically for the presence of contamination, damage, and corrosion. The seal can be protected with glycerine-based lubricants or replaced with a new one, if worn.

## Lights

The lights are made of polycarbonate in a coated steel frame. Clean them with a mild detergent or with a disinfectant suitable for the purpose.

Pay particular attention to the polycarbonate glass, which should be inspected at regular intervals, as shown in the maintenance schedule ("General cleaning of the machine" line).

## Exchangers

If there are dirt and dust deposits on the exchangers, these can be easily removed, using one of the following methods:

- vacuum cleaner, if there is not too much dirt,
- compressed air, if it is very dirty, but it is not firmly fixed, being careful not to damage the wheel,
- hot water (70°C max.) or detergent spray (e.g. Decade, ND-150, Chem Zyme, Primasept, Poly-Det, Oakite 86M or similar) to remove fatty deposits, if the dirt is firmly fixed to many elements.

# Extraordinary maintenance

One can not predict extraordinary maintenance as it is normally due to effects of wear or fatigue caused by the incorrect operation of the machine.

## Replacement of parts



The replacement of parts should be performed by expert personnel:

- Qualified maintenance mechanic
- Qualified maintenance electrician
- Manufacturer technician

The machine is designed to be able to perform all the servicing necessary to maintain good efficiency of the components. However, it sometimes happens that a component fails due to malfunction or wear, so for replacement refer to the executive schematic.

These are the components that may need replacement:

- Filters
- rotary recuperator belts (Modular R)
- Fan
- Recovery/heating/cooling heat exchange coil

For some of these operations of a general nature we will not enter into detail as these are operations that fall within the abilities and professional expertise of the staff assigned to perform them.

## Consumable components - Spare parts

During the operation of the machine there are mechanical and electrical components that are most subject to wear. These parts must be monitored to carry out their replacement or repair before they cause problems to the correct operation of the machine with consequent downtime.

Some parts subject to wear

- cell / pocket / activated charcoal filters
- rotary recuperator transmission belts (Modular R)
- Humidification accessories

The annexes will include a sheet listing the parts subject to wear specific to the machine ordered. For special components like bearings, crankshaft, etc., see the specific annexes detailing the technical specification.

To purchase the spare parts needed for normal and/or extraordinary maintenance, contact Daikin specifying the serial number of the machine noted in the documentation and on the machine's plate.

### DEFINITION OF WASTE

Waste is any substance and object deriving from human activities or natural cycles that is abandoned or destined to be abandoned.

### SPECIAL WASTE

Special waste includes:

- Residues from industrial, agricultural, artisanal, commercial, and service processes that in quality or quantity are considered different from municipal waste.
- Deteriorated or obsolete machinery and equipment.
- Motor vehicles and their parts that can no longer be used.

### HARMFUL TOXIC WASTE

Harmful toxic waste is all waste containing or contaminated by substances listed in the annex to the Italian Presidential Decree 915/52 implementing directives 75/442/EEC, 76/442/EEC, 76/403/EEC, 768/319/EEC. Following are described the types of waste that may be generated during the lifetime of an air handling unit:

- Cell filters from the suction unit.
- Waste oils and greases from lubricating the fan motor assembly.
- Rags or paper soaked with substances used for the cleaning of the various parts of the machine.
- Residues from cleaning the panelling.
- Drive belts.
- UV germicidal lamps, which must be disposed of according to current legislation.



Waste from the cell filters is to be handled as special waste or harmful toxic depending on their use, the sector and the environment in which they are used.

Waste and scraps may cause irreparable damage if dispersed in the environment.

### ELECTRICAL/ELECTRONIC WASTE

Under art. 13 of Italian Legislative Decree no. 49 of 2014 "Implementation of the WEEE Directive 2012/19/EU on electrical and electronic equipment waste.



The logo with the crossed-out bin specifies that the product has been placed on the market after 13 August 2005 and that at the end of its useful life it should not be disposed of with other waste but rather must be collected separately. All equipment is made from recyclable metallic materials (stainless steel, iron, aluminium, galvanised steel, copper, etc.) in a percentage higher than 90% by weight. Before disposal make the equipment unusable by removing the power cord and closing any devices for closing compartments or cavities (where present). It is necessary to pay attention to the management of this product at the end of its life by reducing its negative impact on the environment and improving the effective use of resources, applying the principles of "he who pollutes pays", prevention, preparation for reuse, recycling, and recovery. Remember that the illegal or improper disposal of the product may result in the application of sanctions provided for by current provisions of law.

### Disposal in Italy

In Italy WEEE equipment must be delivered:

- To Collection Centres (also called ecological islands or ecological platforms).
- To the dealer from whom the new equipment was purchased, which is required to collect it free of charge ("one to one" withdrawal).

### Disposal in countries of the European Union

The EU Directive on WEEE equipment has been implemented differently by each country, so to dispose of this equipment we suggest contacting local authorities or the dealer to ask for the correct method of disposal.

# Diagnostics

## General diagnostics

The machine's electrical system includes quality electromechanical components and is therefore extremely durable and reliable over time.

Should there be any malfunctions due to malfunctions of electrical components it will be necessary to act as follows:

- Check the fuses of the power supply for the control circuits and if necessary, replace them with fuses having the same specifications.
- Check if the thermal protection switch for the motor has been triggered or if its fuses have blown.

If this has occurred, it may be caused by:

- Motor overload due to mechanical problems. They need to be solved.
- Incorrect supply voltage. Verify the protection trip threshold.
- Malfunction and/or short circuits in the motor. Identify and replace the failed component.

## Electrical maintenance

The machine does not require routine maintenance repairs.

Do not modify the machine for any reason and do not add other devices.

The manufacturer is not liable for resulting malfunctions and problems.

Further clarification is available by contacting the manufacturer's Customer Service.

# Troubleshooting table

MALFUNCTION TYPE	COMPONENT	POSSIBLE CAUSE/SOLUTION
NOISE	Fan impeller	Impeller deformed, unbalanced or loose
		Nozzle damaged
		Foreign bodies in the fan
	Ducts	Excessive speed in the ducts
Anti-vibration joint too taut		
INSUFFICIENT AIR FLOW	Ducts	Load losses superior to the demand
		Dampers closed
		Obstructions in the ducts
	Filters	too dirty
Heat exchange coils	too dirty	
EXCESSIVE AIR FLOW	Ducts	Load losses inferior to the demand
		Ducts too big
		Terminals not installed
		Transducer failure
		(with pressure control set point too high)
	Machine	Filters not inserted
		Access doors open
Dampers not calibrated		
INSUFFICIENT THERMAL EFFICIENCY	Heat exchange coil	Incorrect connection of inlet/outlet piping
		Heat exchange coil dirty
		Air bubbles in the pipes
		Excessive air flow
	Electric pump	Insufficient water flow
		insufficient pressure
		Wrong direction of rotation
	Fluid	Temperature different from the project
		Incorrect or faulty regulation bodies
WATER LEAK	Heat exchange coil	Leak from the heat exchange coil due to corrosion
	Fan section	Dragging of drops due to high air velocity
		Siphon faulty or not working
		Clogged "overflow" drain



# Repair log

DATE	SERVICE TYPE	TIME REQUIRED	SIGNATURE

# 9 Use

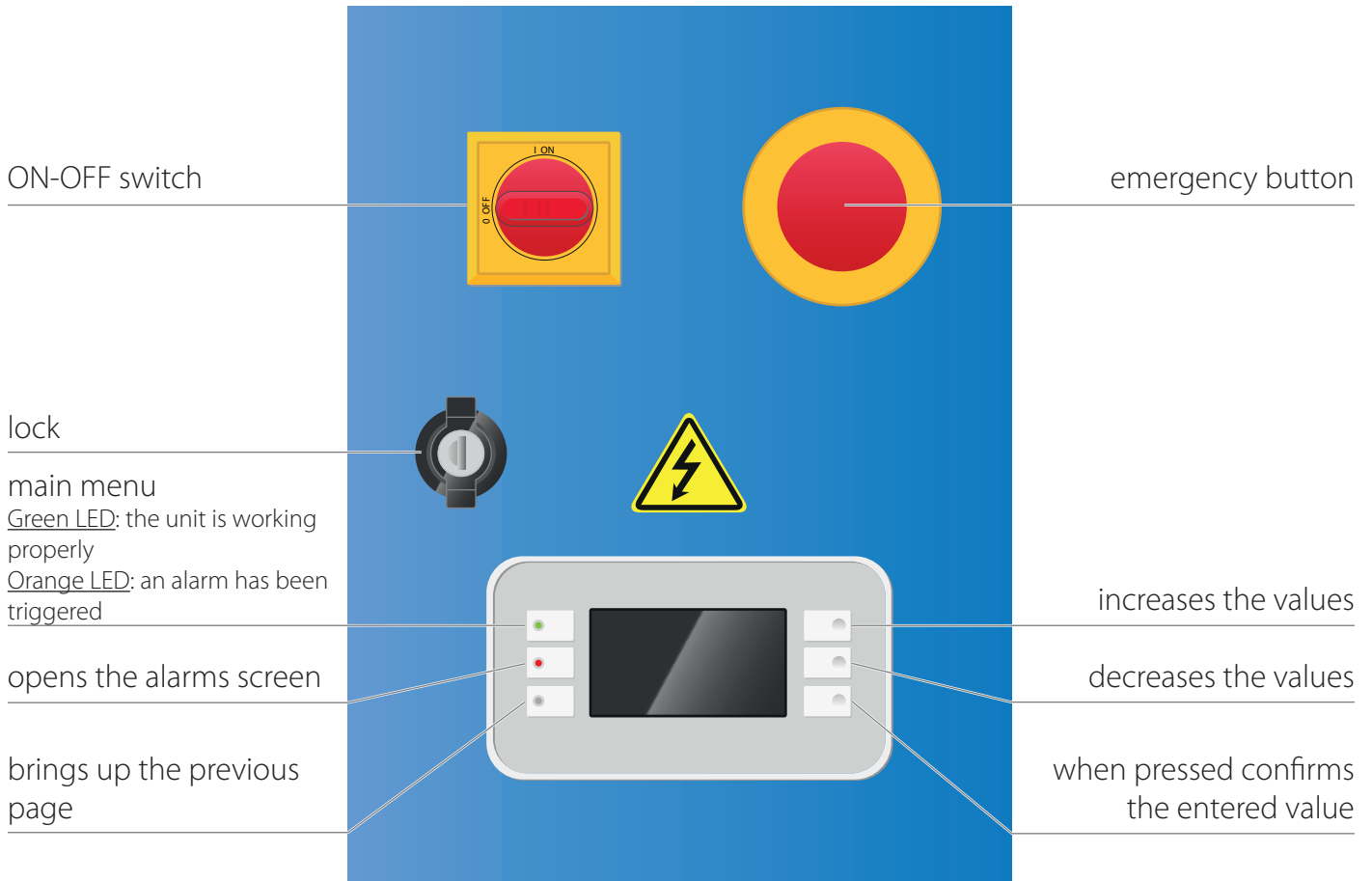
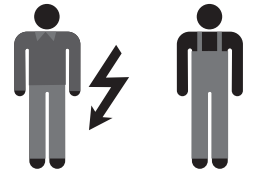

Refer to the Operating Manual for more detailed information on the use of the machine.



For more information email [info@daikinapplied.uk](mailto:info@daikinapplied.uk) or visit [www.daikinapplied.uk](http://www.daikinapplied.uk)

For all Daikin Applied UK,  
Daikin Applied Service &  
Spares enquiries call us on:  
**0345 565 2700**



Daikin Europe N.V. participates in the Eurovent Certified Performance programme for Liquid Chilling Packages and Hydronic Heat Pumps, Fan Coil Units and Variable Refrigerant Flow systems. Check ongoing validity of certificate: [www.eurovent-certification.com](http://www.eurovent-certification.com)

The present publication is drawn up by way of information only and does not constitute an offer binding upon Daikin Europe N.V. Daikin Europe N.V. has compiled the content of this publication to the best of its knowledge. No express or implied warranty is given for the completeness, accuracy, reliability or fitness for particular purpose of its content and the products and services presented therein. Specifications are subject to change without prior notice. Daikin Europe N.V. explicitly rejects any liability for any direct or indirect damage, in the broadest sense, arising from or related to the use and/or interpretation of this publication. All content is copyrighted by Daikin Europe N.V.

