



Installation manual

# Pre-heating water coil Compact T

D-EIMOC2009-28\_01EN

› Compact T

**Original instructions**

REV	01
DATE	October 2024
REPLACES	D-EIMOC2009-28_00EN

# 1 Important warnings



The pictogram shows a situation of immediate danger or a dangerous situation that might cause injuries or death.



The pictogram shows that it is necessary to adopt suitable behaviour in order to avoid jeopardising staff safety and cause damages to the equipment.



The pictogram shows particularly important technical information that should be taken into consideration by the people installing or using the equipment.



Read this manual carefully before installation and keep it for any further future consultation by the various operators. Do not remove, tear out or rewrite any part of this manual.



**Failure to follow these instructions may cause damage and injuries, even fatal, voids the warranty and relieves the Manufacturer of any liability.**



All installation, assembly, electrical connections to the mains and ordinary/extraordinary maintenance must be performed **only by technicians complying with the legal requirements**, after turning off the unit and using personal protective equipment (i.e. gloves, protective goggles, etc.), in compliance with the regulations in force in the country the equipment is to be used in and the laws on safety in the workplace.



Installation, use or maintenance other than those specified in the manual may cause damage, injury or death, invalidate the warranty and relieve the Manufacturer of all liability.



Use protective clothing and suitable equipment while handling or installing the equipment, in order to prevent accidents and safeguard your own and other people's safety. Individuals not assigned to installation or maintenance are NOT allowed to stand or pass through the work area while the unit is assembled.



**Before carrying out any installation, disconnect the equipment from the power supply and wait at least 120 seconds before carrying out any operation.**



It is the responsibility of the user/installer to check the static and dynamic stability relative to the installation and to arrange environments so that **people who are not competent or authorised DO NOT have access to the unit or to its controls.**

## 2 Technical data

Size	Material name	Duct collar diameter [mm]	A [mm]	B [mm]	C [mm]	D [mm]	E [mm]	DN [inch]
03	ATD03HWFAU	250	345	280	110	250	280	1/2
04	ATD04HWFAU	315	420	355	110	315	280	1/2
05	ATD05HWFAU	355	445	380	110	355	280	1/2
06	ATD06HWFAU	400	495	430	110	400	280	1/2
07	ATD07HWFAU	500	595	530	110	500	280	3/4

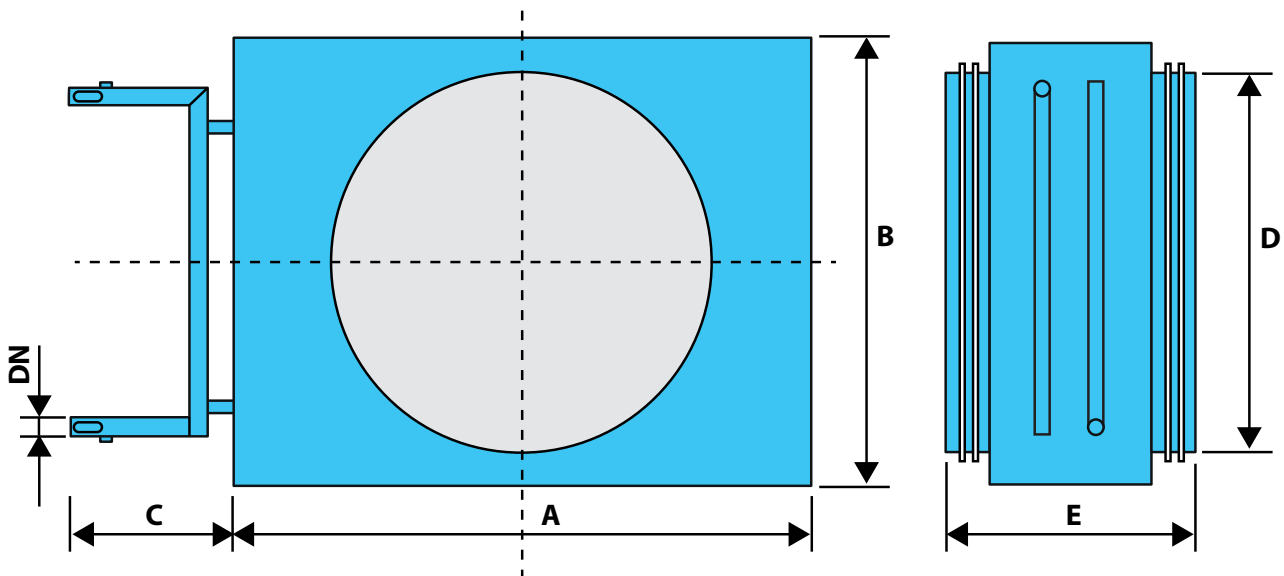

**Right Handling**  
VERSION MACHINES  
**ATB\*\*R\*\***

**Left handling**  
VERSION MACHINES  
**ATB\*\*L\*\***

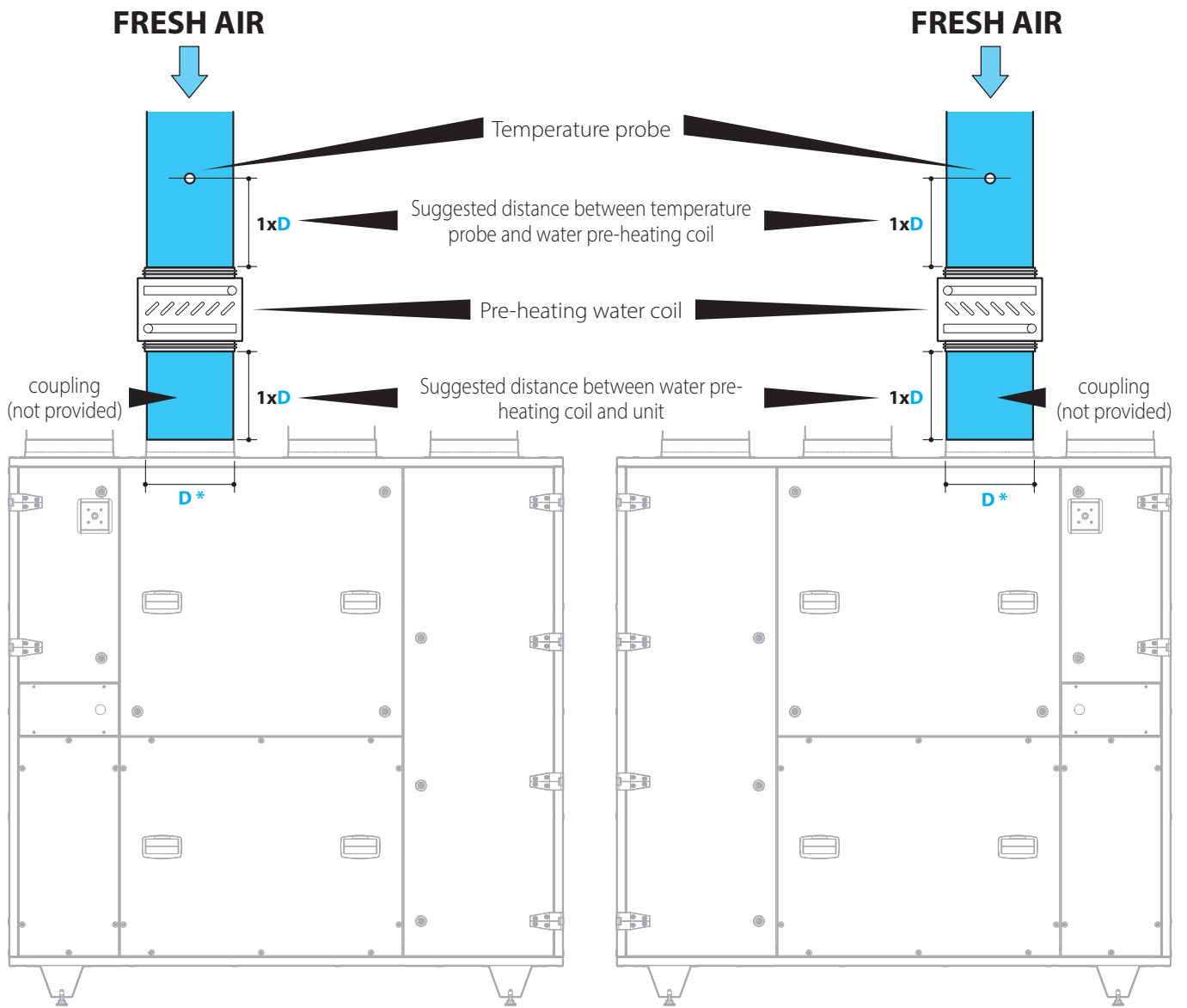

**D\*** = diameter of ducts

(e.g. if **D** = 250 mm ► **1xD** = 250 mm, **2xD** = 500 mm...)

**1** Correct distance

# 3 Installation

## COMPACT T PRO

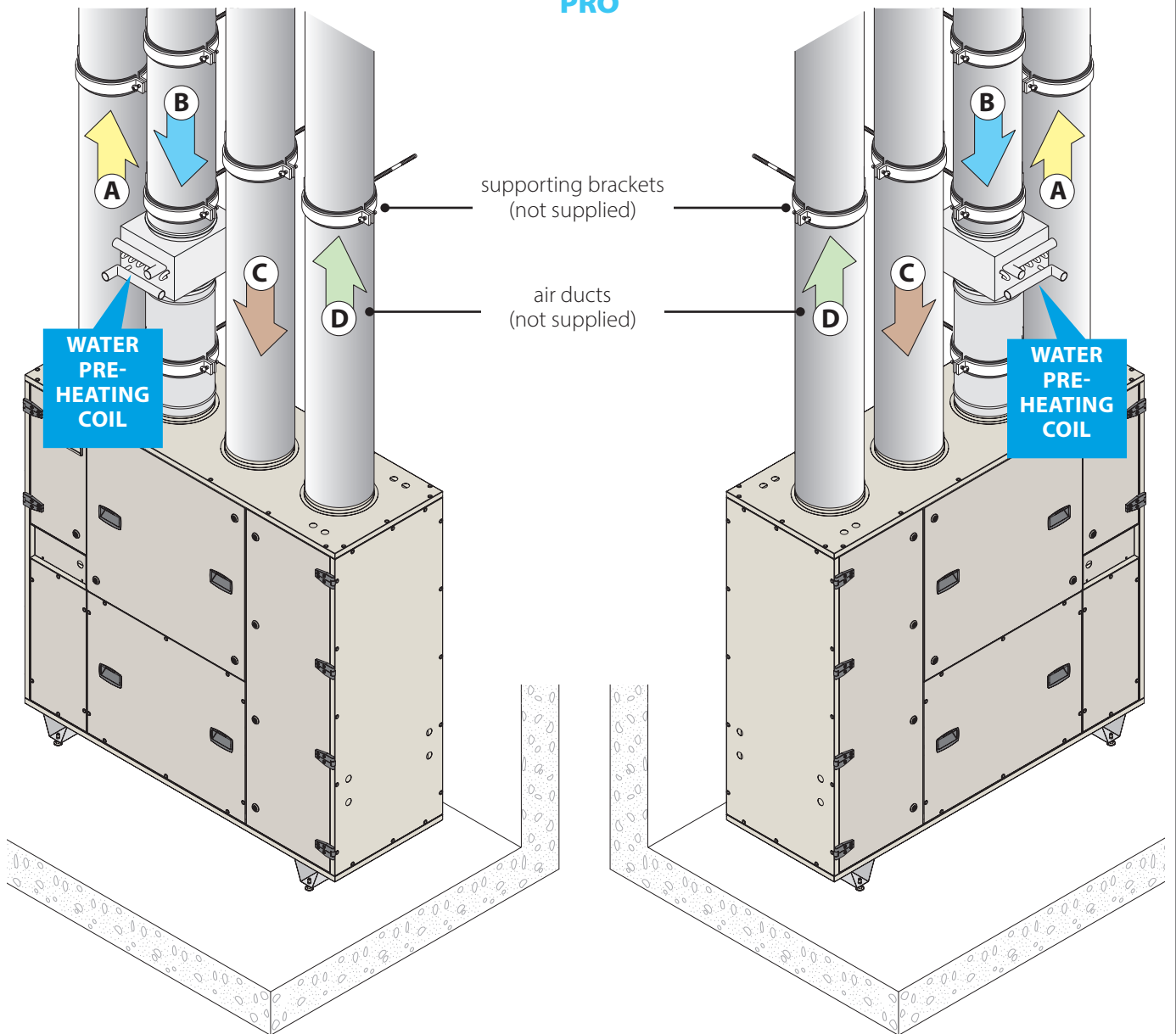

**Right Handling**  
VERSION MACHINES  
**ATB\*\*R\*\***

**Left handling**  
VERSION MACHINES  
**ATB\*\*L\*\***

### DUCT

- A** Exhaust air
- B** Fresh air
- C** Return air
- D** Supply air

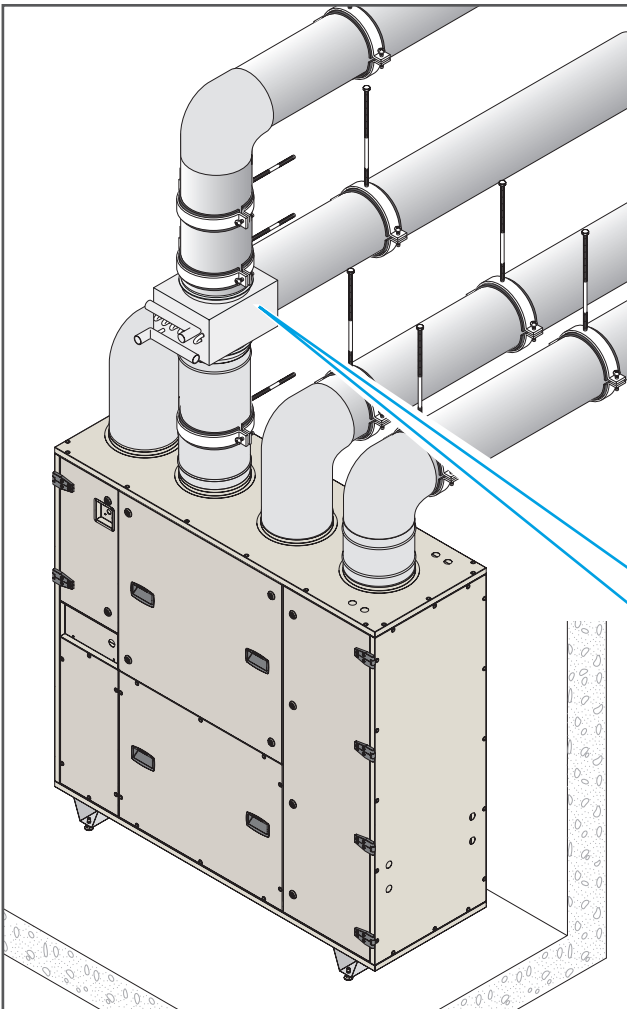

Pre-heating water coil can be positioned both **horizontally** and **vertically**.  
 The ducts and the pre-heating coils must be **permanently fixed to a fixed structure** (for example a wall or a ceiling) using brackets (not supplied).  
 Pre-heating water coil should be installed in such a way that it is accessible for maintenance or any other operation.

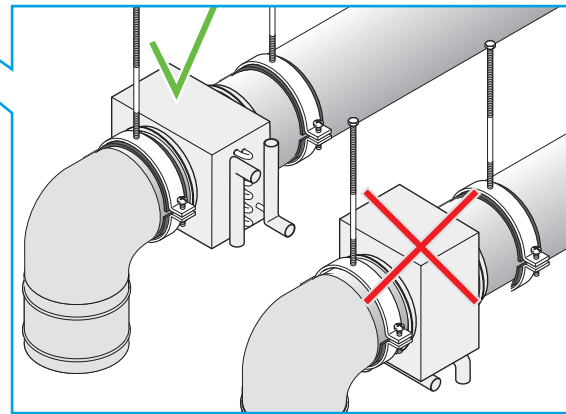

**3** Example of installation of the Pre-heating water coil both horizontally and vertically

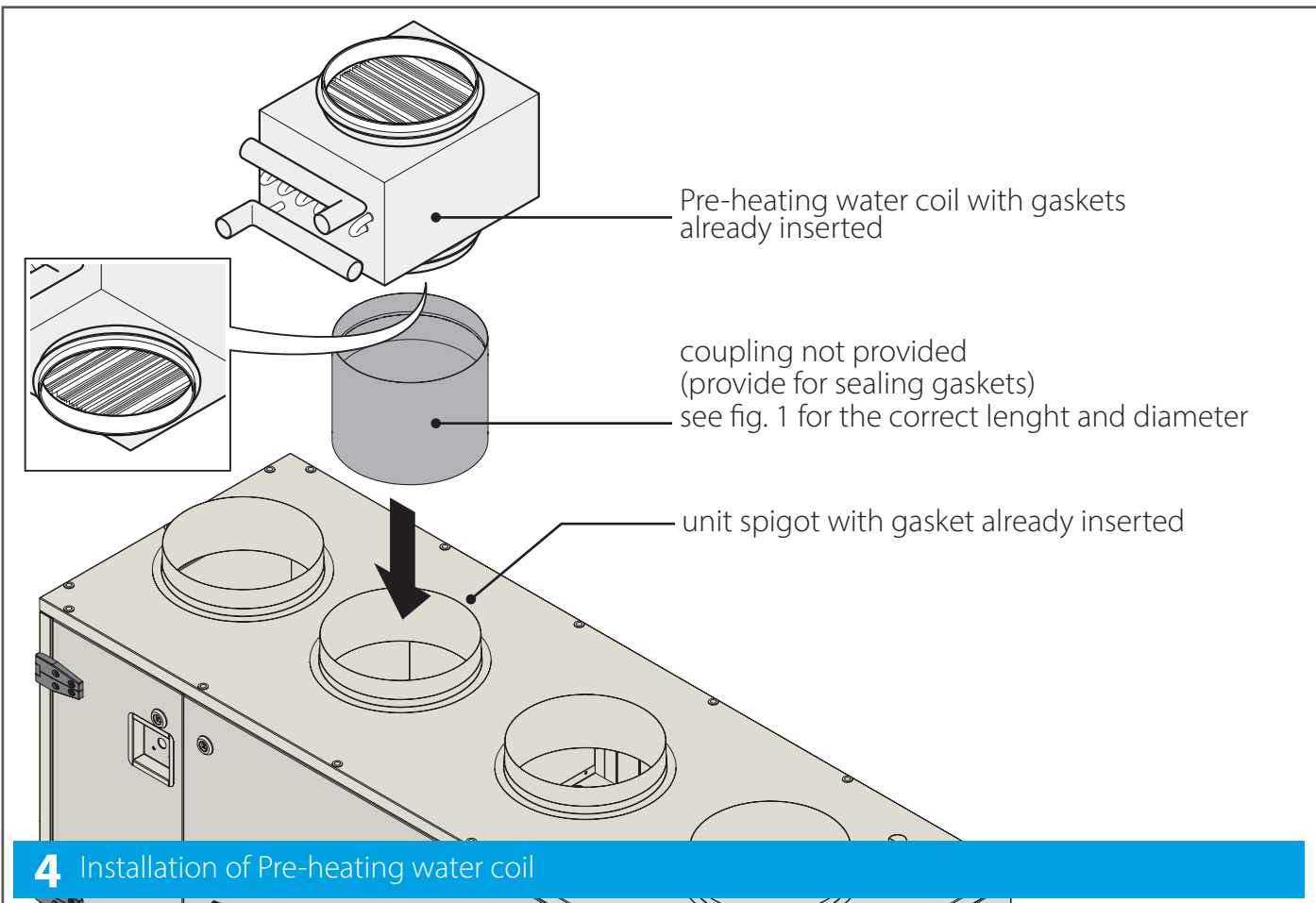

**4** Installation of Pre-heating water coil

# 4 Connection of Pre-heating probe

Right Handling  
VERSION MACHINES  
ATB\*\*R\*\*

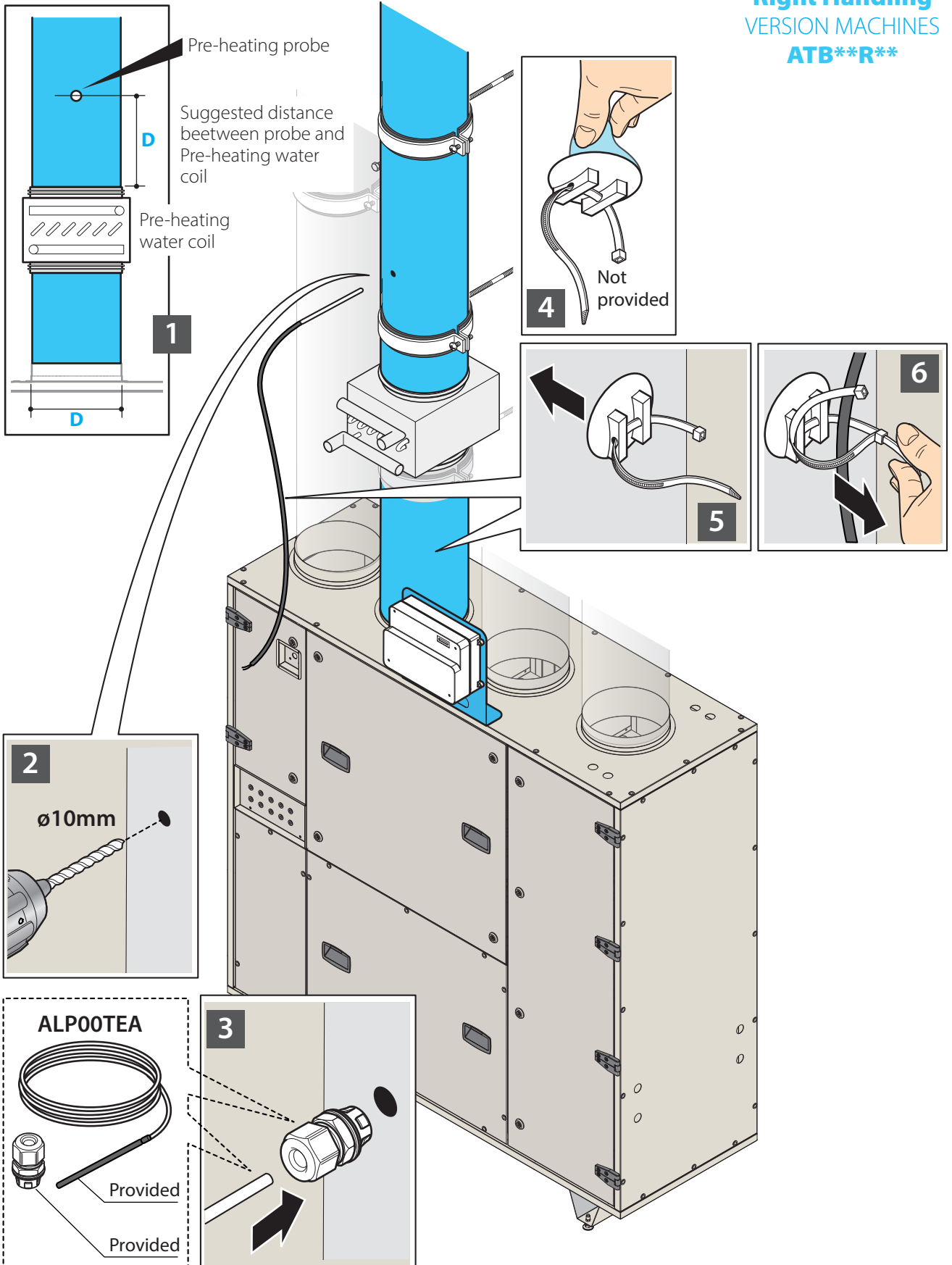

## 5 Installation of probe (PRE-HEATING)

**Left handling**  
VERSION MACHINES  
**ATB\*\*L\*\***

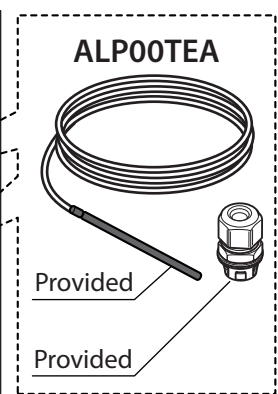
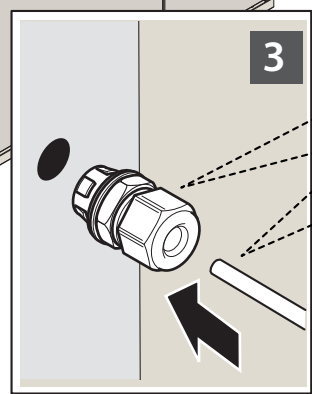
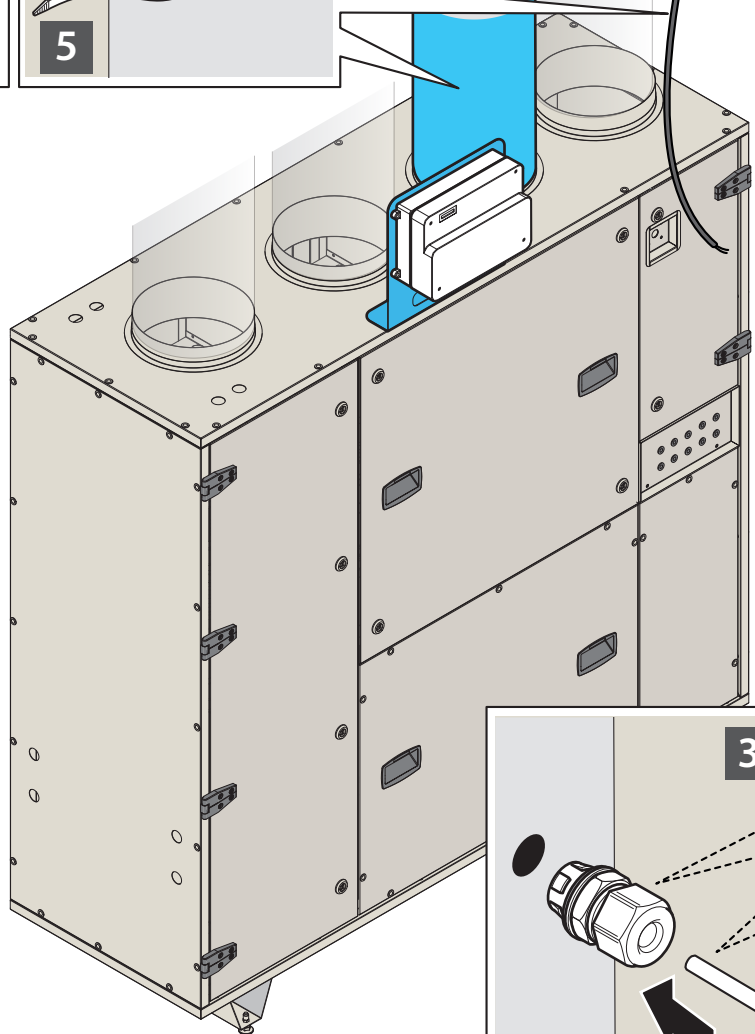
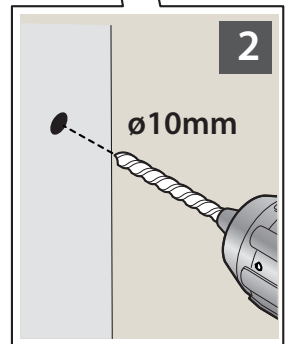
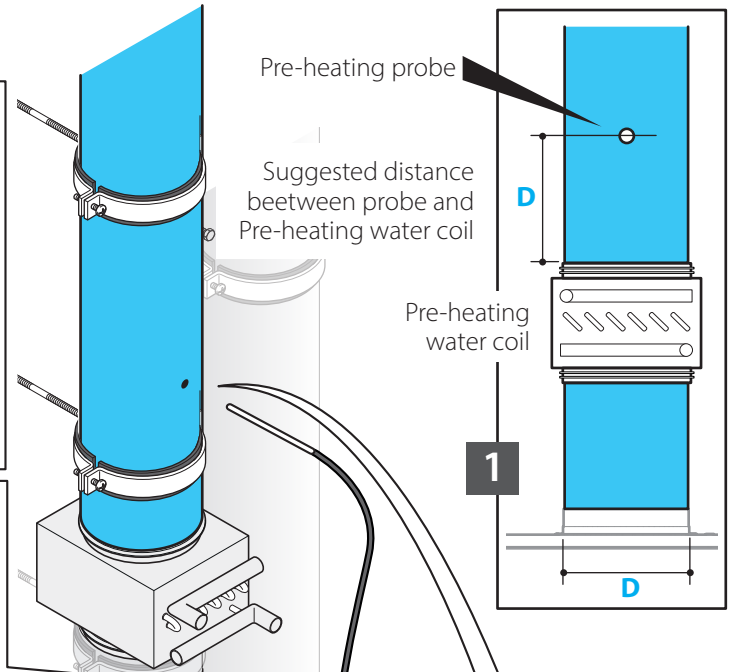
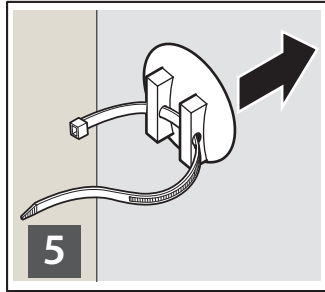
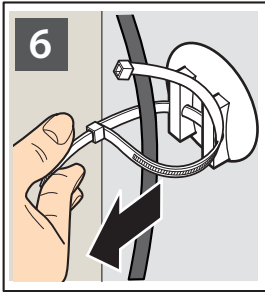
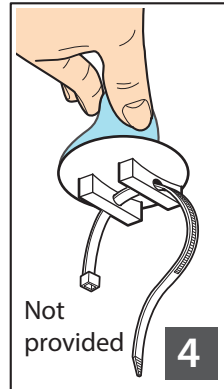

**6** Installation of probe (PRE-HEATING)



**Right Handling**  
VERSION MACHINES  
ATB\*\*R\*\*

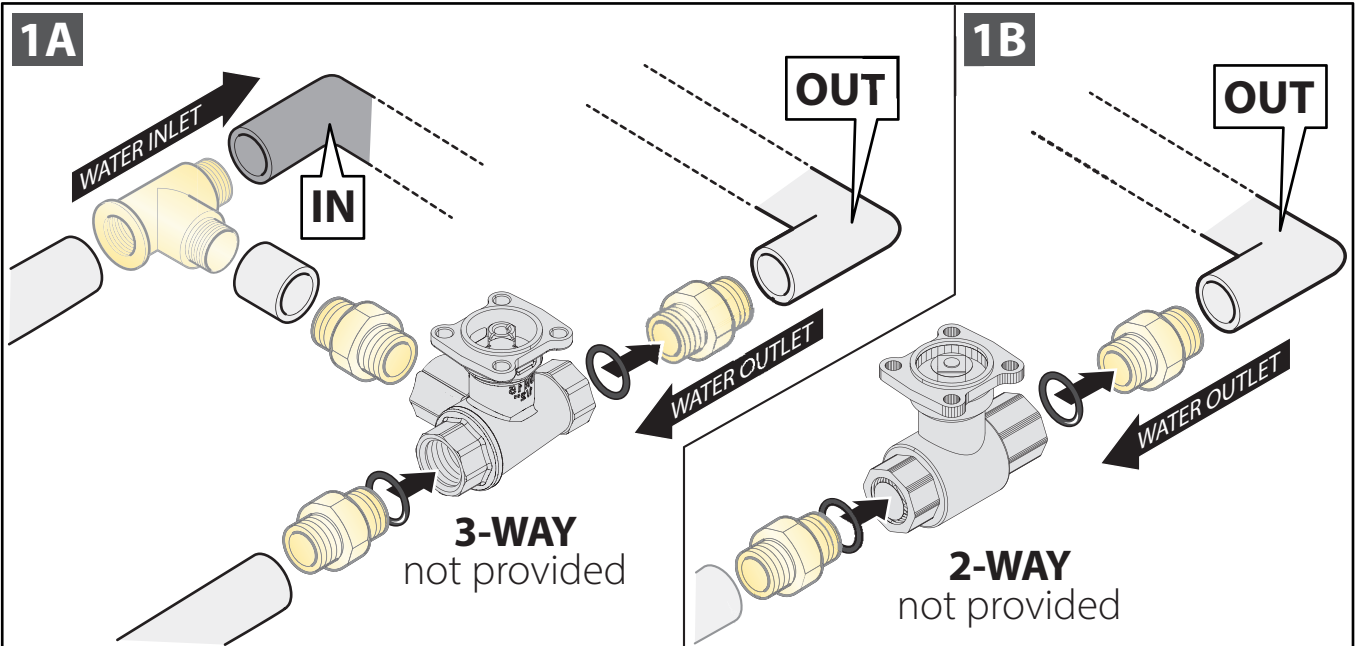
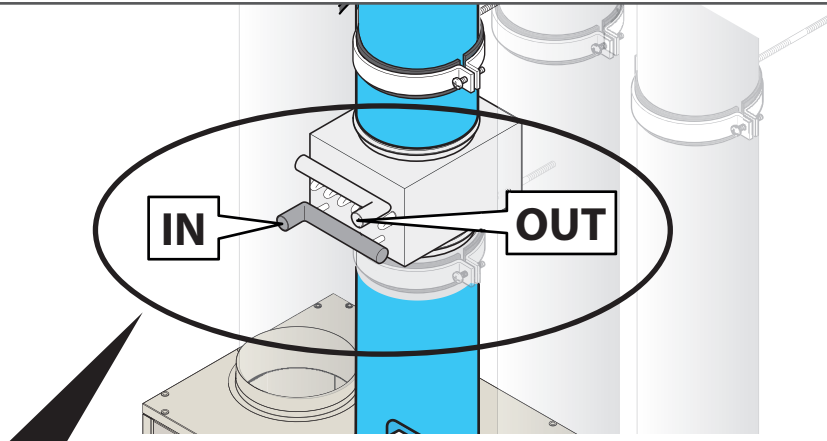

**ATE00AMVA**  
Modulating actuator

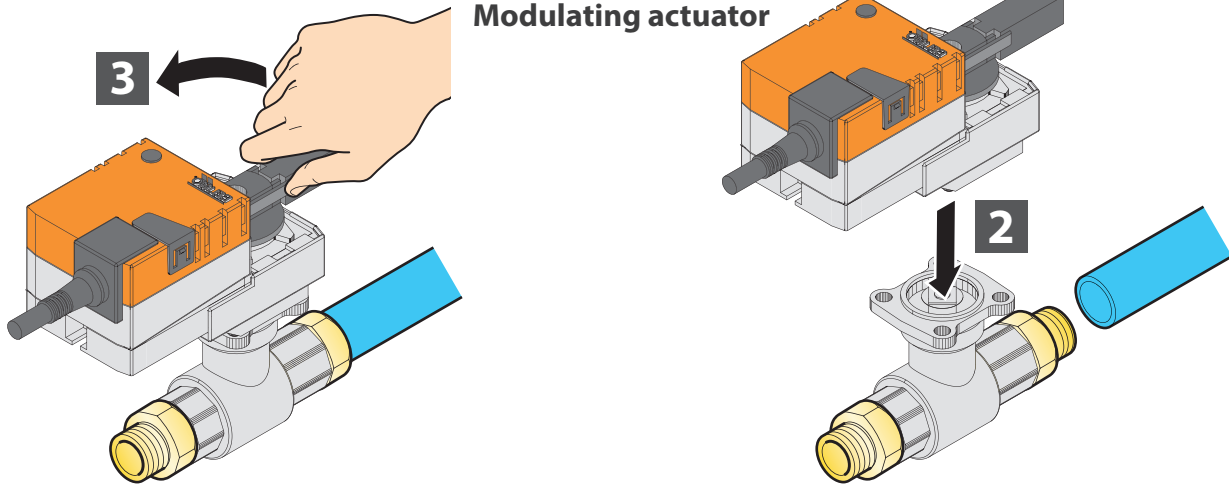

Size	water valves		valve DN [inch]	coil DN [inch]
	2 way	3 way		
03	ATV03CW2A	ATV03CW3A	1/2	1/2
04	ATV04CW2A	ATV04CW3A	1/2	1/2
05	ATV05CW2A	ATV05CW3A	1/2	3/4
06	ATV06CW2A	ATV06CW3A	1/2	3/4
07	ATV07CW2A	ATV07CW3A	3/4	1

**7** Valve and actuator installation (opt.)

**Left handling**  
VERSION MACHINES  
**ATB\*\*L\*\***

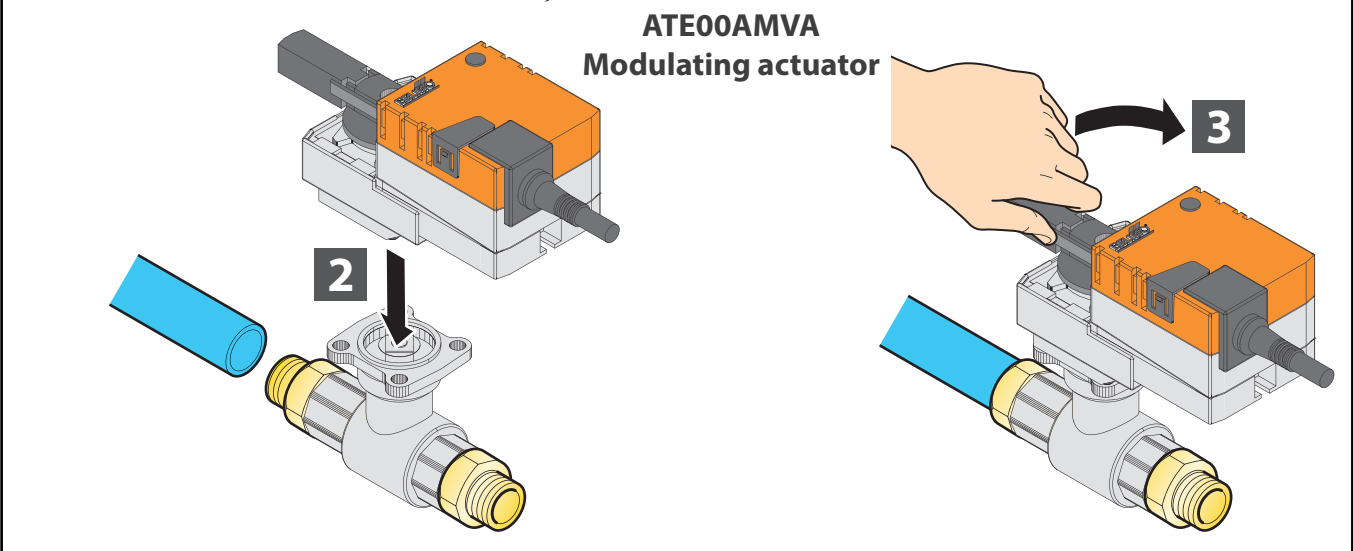
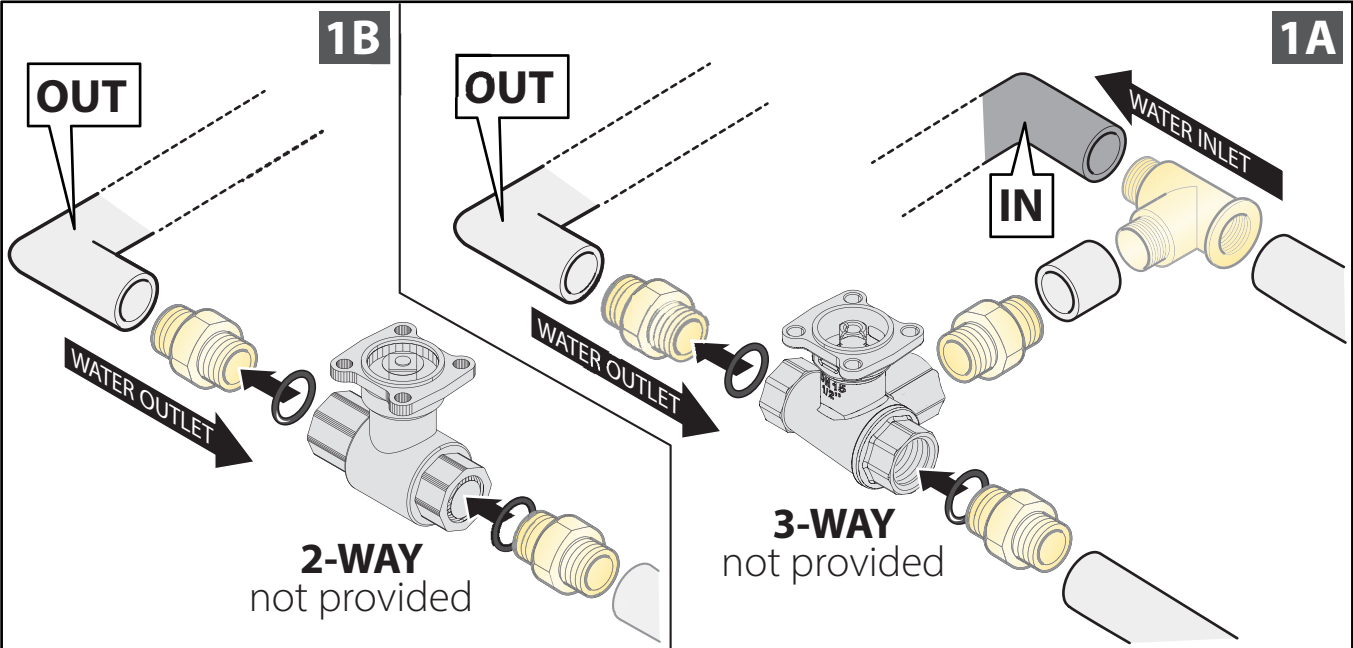
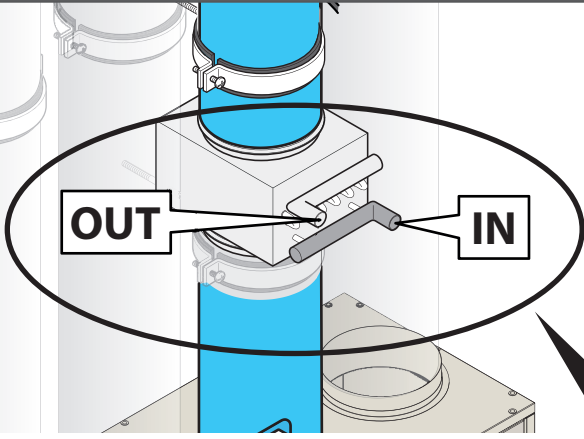

Size	water valves		valve DN [inch]	coil DN [inch]
	2 way	3 way		
03	ATV03CW2A	ATV03CW3A	1/2	1/2
04	ATV04CW2A	ATV04CW3A	1/2	1/2
05	ATV05CW2A	ATV05CW3A	1/2	3/4
06	ATV06CW2A	ATV06CW3A	1/2	3/4
07	ATV07CW2A	ATV07CW3A	3/4	1

**8** Valve and actuator installation (opt.)

Please refer to the dedicated IOM digital node

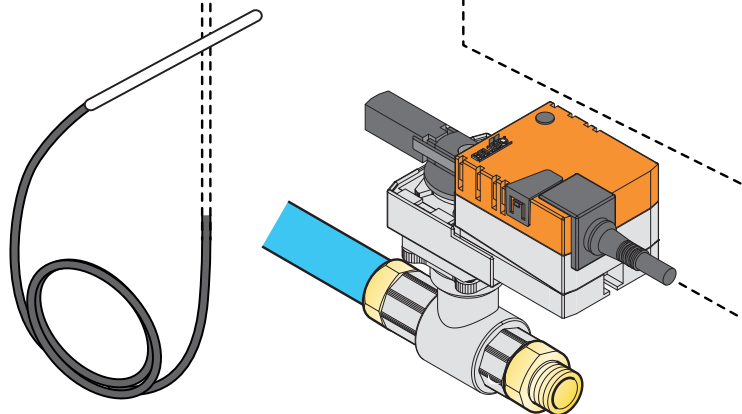
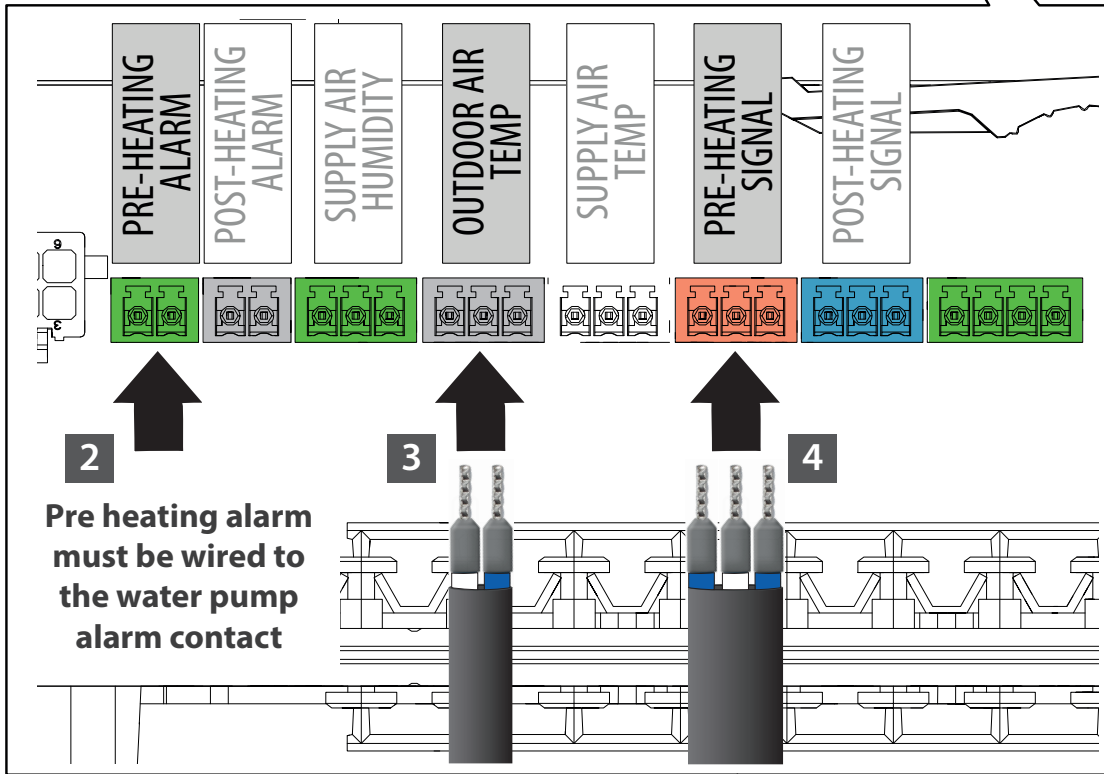
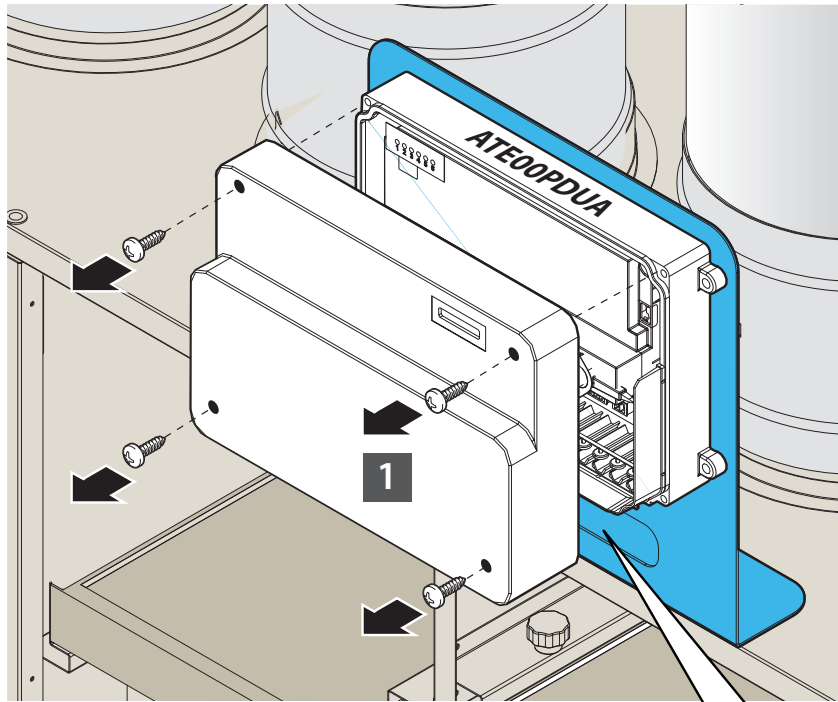

# Software setup (PRE HEATING)

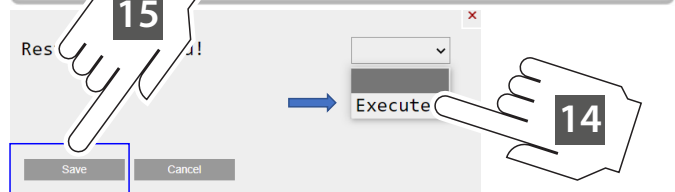
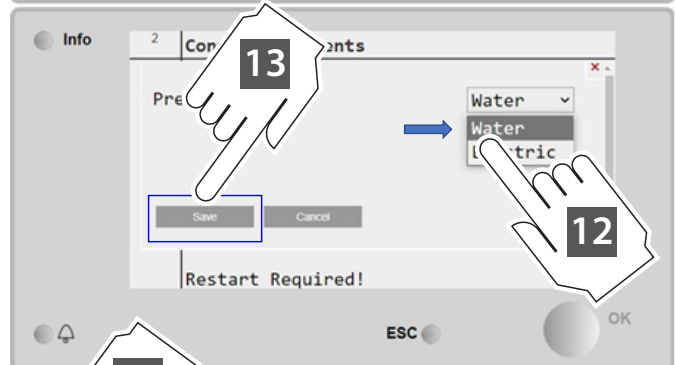
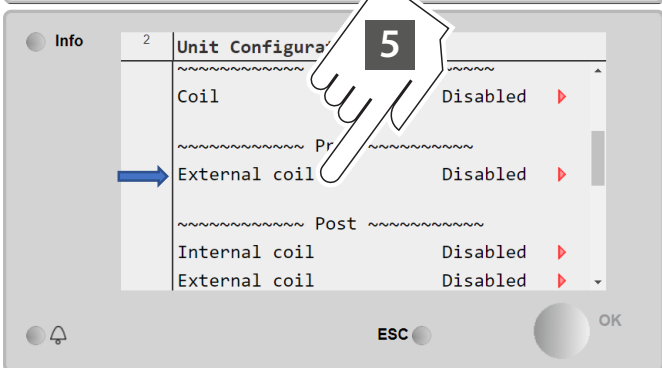
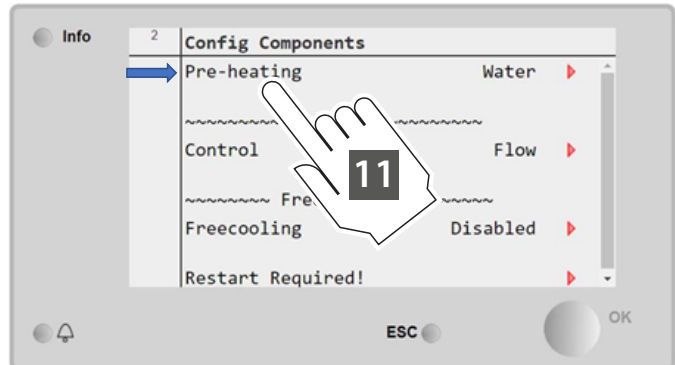
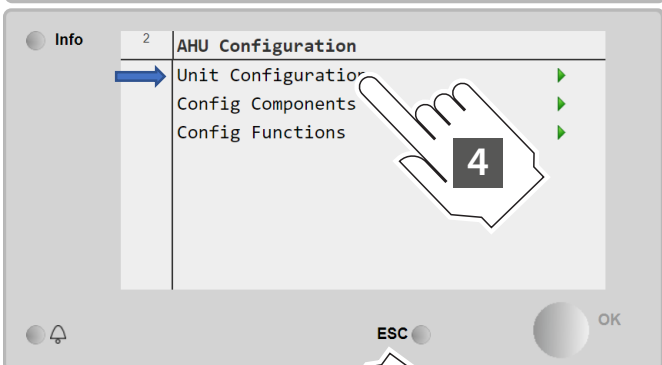
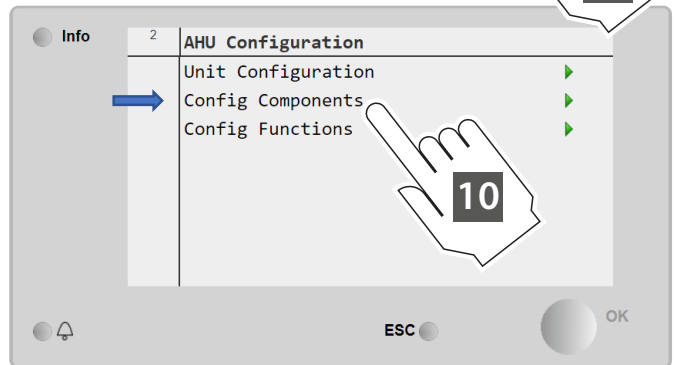
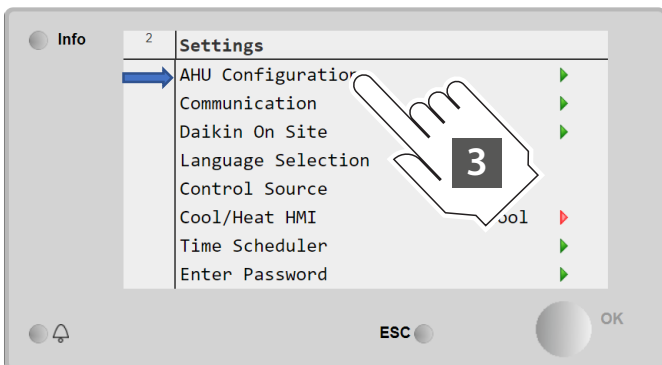
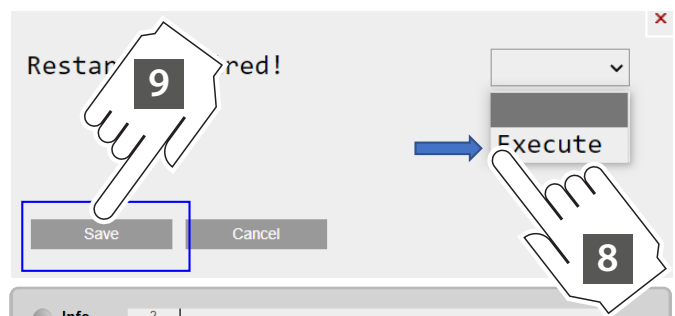
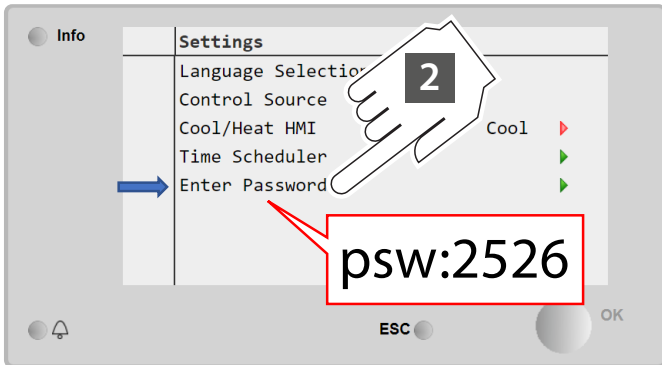
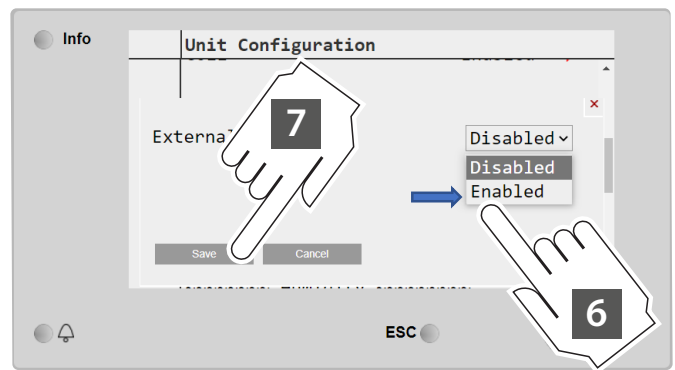
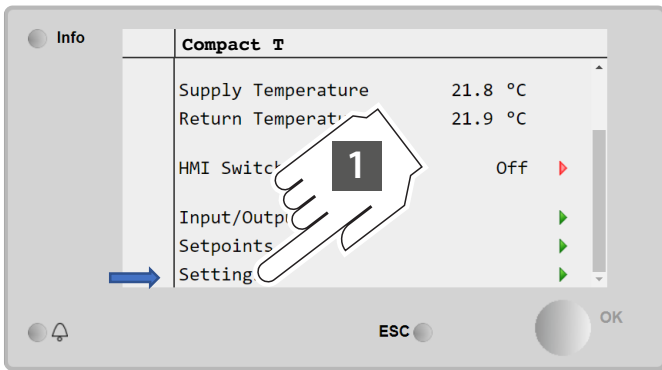



**DAIKIN APPLIED EUROPE S.p.A.** Via Piani S. Maria, 72 - 00072 Ariccia (Rome) Italy - [www.daikinapplied.eu](http://www.daikinapplied.eu)



La presente pubblicazione è redatta solo come supporto tecnico e non costituisce impegno vincolante per Daikin Applied Europe S.p.A. Daikin Applied Europe S.p.A. ne ha compilato il contenuto al meglio delle proprie conoscenze. Nessuna esplicita o implicita garanzia è data per la completezza, precisione, affidabilità del suo contenuto. Tutti i dati e le specifiche in essa riportati sono soggetti a modifiche senza preavviso. Fanno fede i dati comunicati al momento dell'ordine. Daikin Applied Europe S.p.A. respinge esplicitamente qualsiasi responsabilità per qualsiasi danno diretto o indiretto, nel senso più ampio del termine, derivanti o connessi con l'uso e / o l'interpretazione di questa pubblicazione. Tutto il contenuto è protetto da copyright di Daikin Applied Europe S.p.A.

D-EIMOC2009-28\_01EN