



Installation, use and  
maintenance manual

# Compact T Pro ATB

D-EIMAH01706-22\_01EN

› Compact T Pro ATB

Translation of the original instructions

REV	01
DATE	November 2024
REPLACES	D-EIMAH01706-22_00

# Contents

<b>IMPORTANT WARNINGS</b>	<b>3</b>
Purpose of the manual	3
Intended use of the unit	3
Safety regulations	4
Residual risks	6
Safety devices	6
<b>UNIT CHARACTERISTICS</b>	<b>8</b>
Environmental conditions	8
Environmental contamination	8
Noise	8
Floor and air duct specifications	2
Technical data	10
Overall dimensions	11
Safety measurements	13
Summary of unit operation	14
<b>RECEIPT OF THE PACKAGES</b>	<b>16</b>
<b>TRANSPORT</b>	<b>16</b>
<b>UNPACKING AND INTEGRITY CHECK</b>	<b>18</b>
After unpacking	18
Product nomenclature	19
Storage waiting for installation	20
	<b>21</b>
<b>INSTALLATION</b>	
Installation procedure	21
<b>MAINTENANCE</b>	<b>37</b>
Safety precautions for maintenance	37
Ordinary maintenance	38
Extraordinary maintenance	41
Disposal of used materials - waste	44
Diagnostics	44
Troubleshooting table	45
Optional accessory assembly	46
Repair log	47

# 1 Important warnings



The pictogram shows a situation of immediate danger or a dangerous situation that might cause injuries or death.



The pictogram shows that it is necessary to adopt suitable behaviour in order to avoid jeopardising staff safety and cause damages to the equipment.



The pictogram shows particularly important technical information that should be taken into consideration by the people installing or using the equipment.

## Purpose of the manual

The purpose of this **manual** is to guide the installer and qualified operator in the installation, maintenance and proper and safe use of the equipment. For this reason, **it is mandatory for all personnel involved in installation, maintenance and supervision of the unit to read this manual.**

Contact the manufacturer if any points are unclear or difficult to understand.

This manual contains information regarding:

- technical specifications of the unit;
- instructions for transport, handling, installation and assembly;
- use;
- information for instructing personnel authorised for its use;
- maintenance.

All the information provided generally refers to any unit of the Compact T range. All units are shipped together with a **technical drawing**, indicating the specific weight and size of the unit received. It must be considered an integral part of this manual and therefore it must be kept with the utmost care in all its parts.

If the manual or drawing is lost, it is important to request a copy from the Manufacturer, specifying the unit's serial number that can be found on the label on the unit itself.

In the case of divergent information between this manual and the drawing, the drawing will prevail.

## Intended use of the unit

This appliance has the function of treating the air intended to condition civil and industrial environments. Any other use is not in accordance with the intended use and therefore dangerous.

This range of units is designed to be used in NON-explosive environments.

This range of units is designed for installation inside buildings

If the unit is used in critical situations, by type of system or environmental context, the customer must identify and adopt the technical and operational measures to avoid damage of any kind.

# Safety regulations

## SKILLS REQUIRED FOR THE INSTALLATION OF THE UNIT



Installers must perform operations according to their professional qualifications: all activities not within one's expertise (i.e. electrical connections) must be carried out by specialised and qualified staff so as not to endanger one's safety and the safety of the other operators interacting with the unit.



**Equipment transport and handling operator:** authorised person with recognised expertise in using transport and lifting equipment.



**Technical installer:** expert technician, sent or authorized by the manufacturer or its representative, with adequate skills and training to install the unit.

**Assistant:** technician subject to care obligations while lifting and assembling the equipment. He must be suitably trained and informed about the operations to perform and the safety plans of the site/installation location.

In this manual, the technician competent to carry out each operation is specified.

## SKILLS REQUIRED FOR THE USE AND MAINTENANCE OF THE UNIT



**Generic operator:** AUTHORISED to run the unit using commands placed on the keypad of the electrical control panel. Performs only unit control operations, power on/off.

**Maintenance mechanic (qualified):** AUTHORISED to carry out maintenance, adjustments, replacement and repair of mechanical parts. It must be a person competent in mechanical systems, therefore able to perform mechanical maintenance in a satisfactory and safe manner, must possess theoretical preparation and manual experience. NOT AUTHORISED to work on electrical systems.

**Manufacturer's technician (qualified):** AUTHORISED to perform complicated operations in every situation. Operates in accordance with the user.



**Maintenance electrician (qualified):** AUTHORISED to perform service of an electric nature, adjustments, maintenance and electrical repairs. AUTHORISED to operate in the presence of an active electrical connection inside the control panels and junction boxes. It must be a person competent in electronics and electrical engineering, therefore able to work on electrical systems satisfactorily and safely, must possess theoretical knowledge and proven experience. NOT AUTHORISED to work on mechanical systems.



Installers, users and maintenance technicians CANNOT work on the unit if they:

- are without experience and responsibility or minors;
- are in inadequate psycho-physical conditions;
- do not master the operating cycle of the unit;
- have not attended theoretical/practical training alongside an expert unit operator or user, or alongside a Manufacturer's technician.

In this manual, the technician competent to carry out each operation is specified.



Read this manual carefully before unit installation and maintenance and keep it for any further future consultation by the various operators. Do not remove, tear out or rewrite any part of this manual.



**Failure to follow these instructions may cause damage and injuries, even fatal, voids the warranty and relieves the Manufacturer of any liability.**



All installation, assembly, electrical connections to the mains and ordinary/extraordinary maintenance must be performed **only by technicians complying with the legal requirements**, after turning off the unit and using personal protective equipment (i.e. gloves, protective goggles, etc.), in compliance with the regulations in force in the country the equipment is to be used in and the laws on safety in the workplace.



Installation, use or maintenance other than those specified in the manual may cause damage, injury or death, invalidate the warranty and relieve the Manufacturer of all liability.



Use protective clothing and suitable equipment while handling or installing the equipment, in order to prevent accidents and safeguard your own and other people's safety. Individuals not assigned to installation or maintenance are NOT allowed to stand or pass through the work area while the unit is assembled.



**Before carrying out any installation or maintenance, disconnect the equipment from the power supply and wait at least 120 seconds before carrying out any operation.**



Before installing the equipment, check that the systems comply with the legal provisions in force in the country of use and meet the specifications on the serial number plate.



It is the responsibility of the user/installer to check the static and dynamic stability relative to the installation and to arrange environments so that **people who are not competent or authorised DO NOT have access to the unit or to its controls.**



It is the responsibility of the user/installer to make sure that **weather conditions** do not affect the safety of persons and property during installation, use and maintenance.



Make sure the air intake is not located near any exhausts, flue-gases or other contaminating elements.



Do not install the equipment in places exposed to strong winds, salt air or open flames.



After installation is complete, instruct the user on the correct use of the unit.

If the equipment does not work or functional or structural alterations are noted, disconnect it from the power supply and contact a service centre authorised by the Manufacturer or Retailer, without attempting to repair it on your own. For any replacements request the use of original spare parts. Unauthorised actions, tampering or modifications that do not follow the information provided in this manual can cause damage, injuries or fatal accidents and void the warranty.

The serial number plate on the unit provides important technical information, essential in case of unit maintenance or repairs. We recommend that you do not remove, damage or modify it.



In order to ensure correct and safe conditions of use, we recommend you have the unit maintained and checked at least annually by a service centre authorised by the Manufacturer or Dealer.

# Residual risks

Despite having implemented and adopted all the safety measures indicated by applicable regulations, some residual risks remain. In particular, in some operations of replacement, adjustment and tooling maximum attention is always required in order to work in the best possible conditions.

## LIST OF OPERATIONS WITH RESIDUAL RISKS

Risks for qualified personnel (electricians and mechanics):

- handling - during unloading and handling it is necessary to pay attention to all the steps listed in this manual regarding the points of reference;
- installation - during installation it is necessary to pay attention to all the steps listed in this manual regarding the points of reference the installer must ensure the static and dynamic stability of the unit's site of installation;
- maintenance - during maintenance it is necessary to pay attention to all the steps listed in this manual, and in particular to high temperatures that may be present in the heat transfer fluid lines to/from the unit;
- cleaning - the unit must be cleaned only when it is switched off, by turning off the switch installed by the electrician and the switch located on the unit itself. The key for interrupting the power supply must be kept by the operator until the end of the cleaning operations. Internal cleaning of the unit must be carried out using the protections required by current regulations. While the inside of the unit does not contain particular hazards, it is necessary to pay the utmost attention so that accidents do not occur during cleaning. The coils that have a potentially sharp finned pack must be cleaned using suitable protective goggles and gloves. During adjustment, maintenance and cleaning there are residual risks of variable entity. Being operations that must be performed with guards disabled, it is necessary to pay particular attention in order to avoid damage to persons and things.



Always pay close attention when performing the operations specified above. Remember that these operations must always be performed by authorised personnel.

All work must be completed in accordance with the legal provisions relating to work safety. Remember that the unit in question is an integral part of a larger system that includes other components, depending on the final characteristics of realisation and the mode of use. Therefore in the end it is the responsibility of the user and assembler to assess the residual risks and their respective preventive measures.

## SAFETY DEVICES



The unit is equipped with safety devices to prevent risks of damage to persons and for proper operation. Always pay attention to the symbols and safety devices on the unit. It should **only** operate with the safety devices engaged and with fixed or movable guards installed correctly and in the proper position.



If during installation, use or maintenance the safety devices have been temporarily removed or disabled, the unit can be operated **exclusively** by the qualified technician who made this change. It is **mandatory** to prevent other people's access to the unit. When finished, restore the devices to their proper status as soon as possible.

# Information signs



Fresh air right  
62x62 mm



Fresh air left  
62x62 mm



Damper  
62x62 mm



Cold water outlet  
62x62 mm



Condensate drain  
62x62 mm



Exhaust air right  
62x62 mm



Exhaust air left  
62x62 mm



Drop separator  
62x62 mm

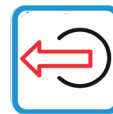

Hot water outlet  
62x62 mm



Antifrost  
62x62 mm



Air supply right  
62x62 mm



Air supply left  
62x62 mm



Fans  
62x62 mm



Filter  
62x62 mm

Daikin  
310x70 mm



Return air right  
62x62 mm



Return air left  
62x62 mm



Electric coil  
62x62 mm



Heat exchange coil  
62x62 mm



Unit label  
102x102 mm



Cold water inlet  
62x62 mm



Heat recuperator  
62x62 mm



Liquid coolant inlet  
62x62 mm



Moving parts  
62x62 mm



Hot water inlet  
62x62 mm



Humidification  
62x62 mm



Vapour coolant outlet  
62x62 mm



Silencer  
62x62 mm



135x45 mm

# Safety signs



Lifting

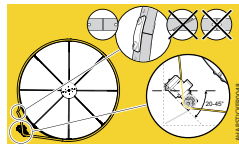

Belt tensioning

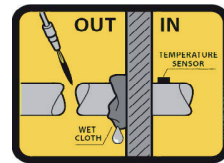

Risk of brazing the temperature sensor



Safety handle positive pressure

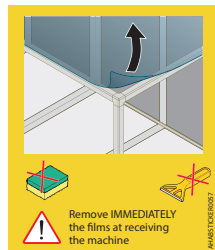

Roof film removal



Grounding



Fire hazard

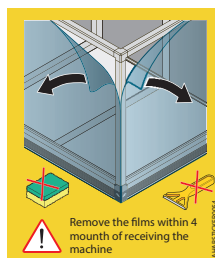

Remove the film from the panels



Electric shock hazard



Electrical hazard

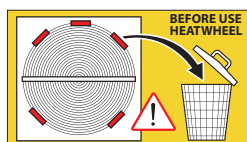

Removal of heat wheel blocks before the unit first start-up



Danger of running fans

# 2 Unit characteristics

Compact T units are produced in a standard version which includes an aluminium plate heat exchanger, ePM1 50% (F7) class filter in supply and ePM10 75% (M5) class filter in return, 50 mm double skin panel with insulation in mineral wool.

The accessories can be purchased separately as an option and installed on site.

## Environmental conditions



Compact T heat recovery units are designed for use in indoor environments, installed on the ceiling. The unit cannot operate in environments containing explosive material and with a high concentration of dust.



Outside air temperature	- 38°C + 46°C**  **Note: from -16° is recommended a preheating (water or electric)
Operating environment temperature	+5°C to +46°C
Temperature of the environment with the unit off (e.g., storage, transport, etc.)	from -40°C to +60°C

Thanks to its modularity, each unit is able to adapt to different needs in terms of air flow and thermodynamic treatments.

## Environmental contamination

Depending on the installation operating environment, specific regulations must be followed and all the necessary precautions must be taken to avoid environmental issues (a system that operates in a hospital or chemical environment can have problems different from those in other sectors, even from the point of view of disposal of consumable parts, filters, etc.).

It is mandatory for the buyer to inform and train workers regarding proper procedures.

## Noise



The units have been designed and manufactured in such a way as to produce sound emissions below the threshold of **80 dB(A)**. It should be noted that every environment has its own acoustic characteristics that can greatly affect the pressure values perceived during operation, therefore it is necessary to consider the noise level data provided as a point of reference, while it is up to the buyer to carry out the specific phonometric surveys on the installation site and in the real conditions the unit will be used.



# Floor and air duct specifications

The **floor** where you plan to position the unit **must** be:

- perfectly flat and without roughness;
- vibration resistant;
- able to **support the weight of the equipment considering an appropriate safety margin** (see table of technical data on page 10).

**1** The **air ducts** (not supplied) must be connected directly to the unit: when assembly is completed, they must not be stretched, in order to avoid damage and transmission of vibrations. To ensure the seal of the connections and the integrity of the unit, it is essential that the air ducts be supported by special brackets (not supplied) that do not weigh directly on the unit.

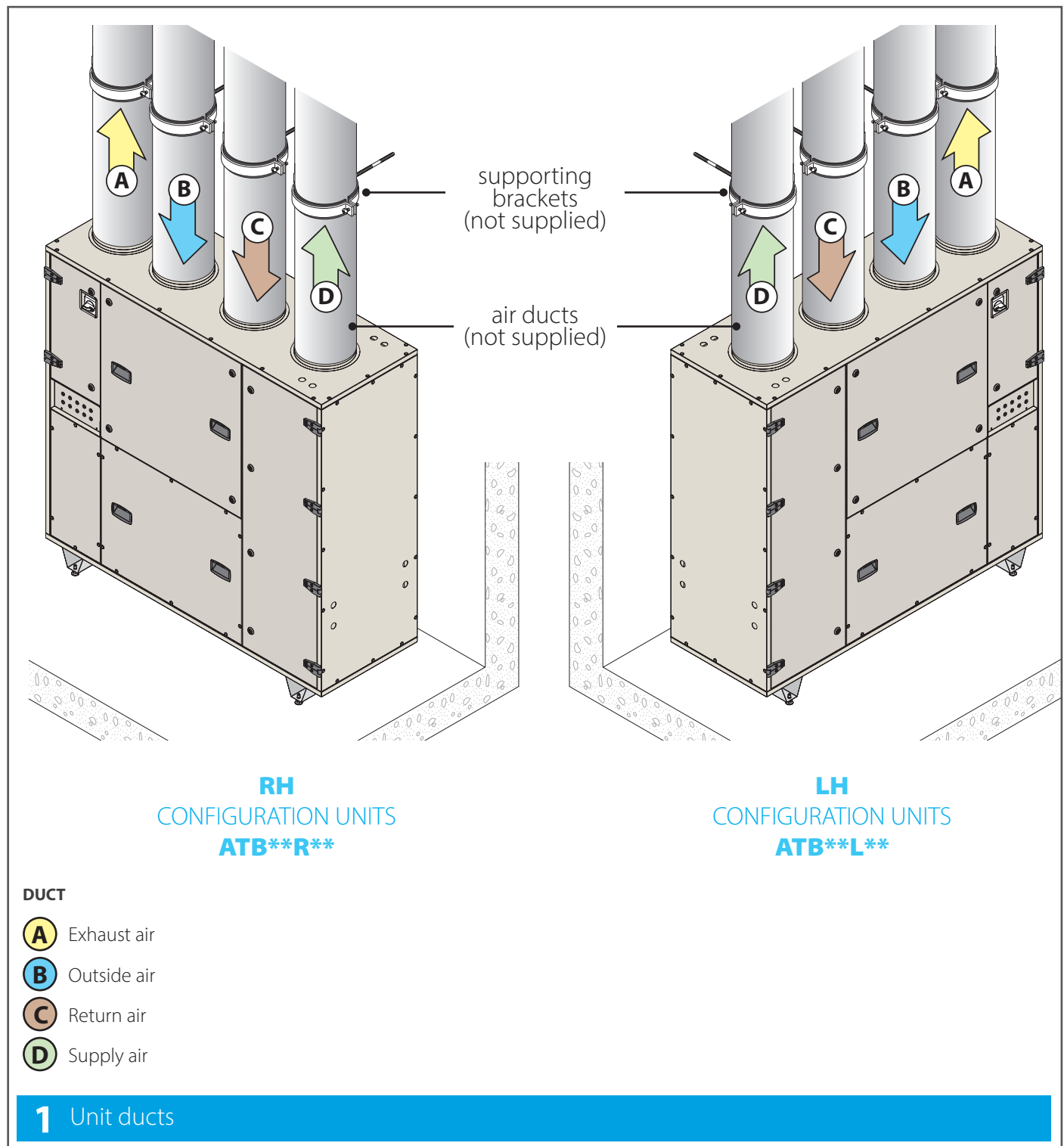

# Technical data

TECHNICAL DATA TABLE	SIZE					
	u.m.	03	04	05	06	07
Nominal air flow rate	m <sup>3</sup> /h	800	1650	2300	2700	3900
Thermal efficiency	%	89	88	85	90	91
FLA	A	4,4	5,5	6,9	9,0	11,8
FLI	W	1020	1270	1580	2060	2720
Electrical connection	V	230 V, 1 ph	230 V, 1 ph	230 V, 1 ph	230 V, 1 ph	230 V, 1 ph

WEIGHT TABLE	UNIT/SECTION										
	u.m.	ATB 03	ATB 04	05		06			07		
				ATB 15	ATB 25	ATB 16	ATB 26	ATB 36	ATB 17	ATB 27	ATB 37
Gross weight with packaging	kg	200	245	135	265	150	265	105	185	320	125
Device weight	kg	185	230	120	250	135	250	90	170	305	110
Filter weight	kg	1	1	0,5	0,5	0,5	0,5	-	0,5	0,5	-
Fan weight	kg	11	11	12	12	14	14	-	21	21	-
Heat recuperator weight	kg	11	17	-	26	-	36	-	-	46	-

# Overall dimensions

CAPTION ON PAGE 13

## RIGHT CONFIGURATION UNITS

**SIZE 3-4:** unit with one section, B

**SECTION B:** heat recuperator + electrical panel + supply

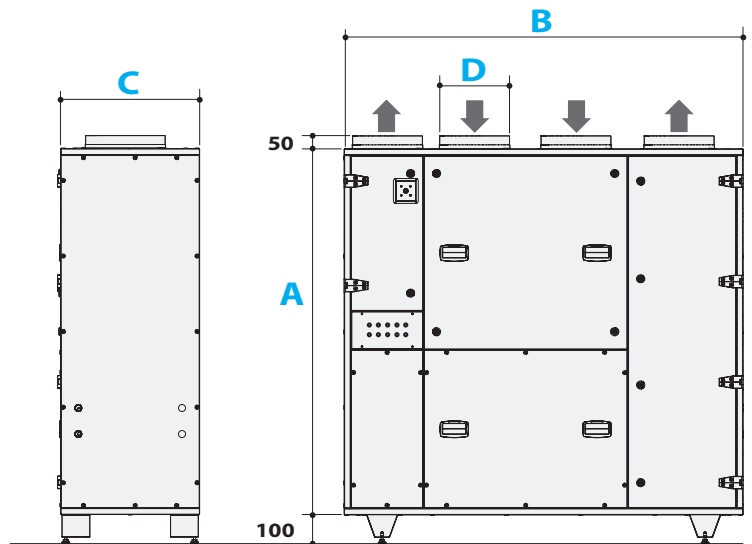

**SIZE 5:** unit with two sections, B1 and B2

**SECTION B1:** supply

**SECTION B2:** heat recuperator + electrical panel

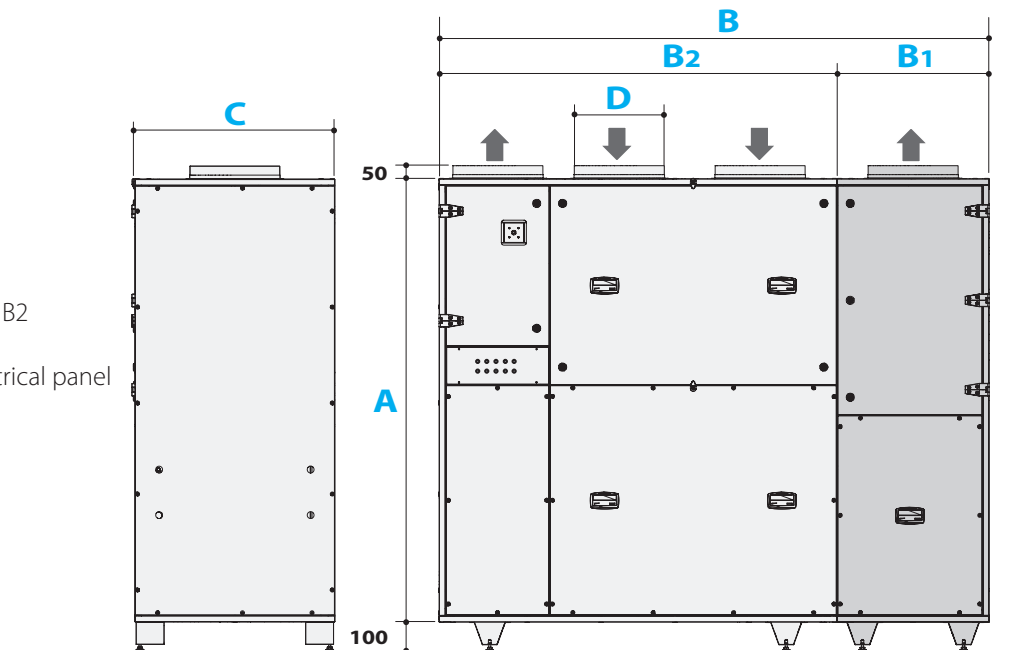

**SIZE 6-7:** unit with three sections, B1, B2, B3

**SECTION B1:** supply

**SECTION B2:** heat recuperator

**SECTION B3:** electrical panel

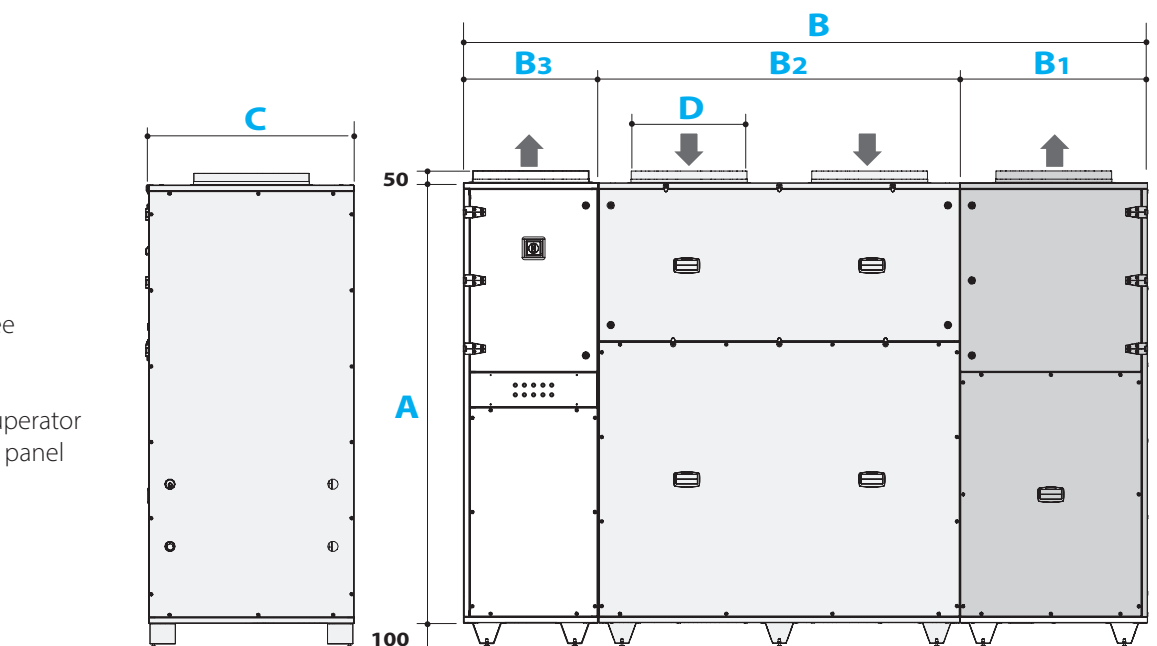

(mm)

**LEFT**  
CONFIGURATION UNITS

CAPTION ON PAGE 13

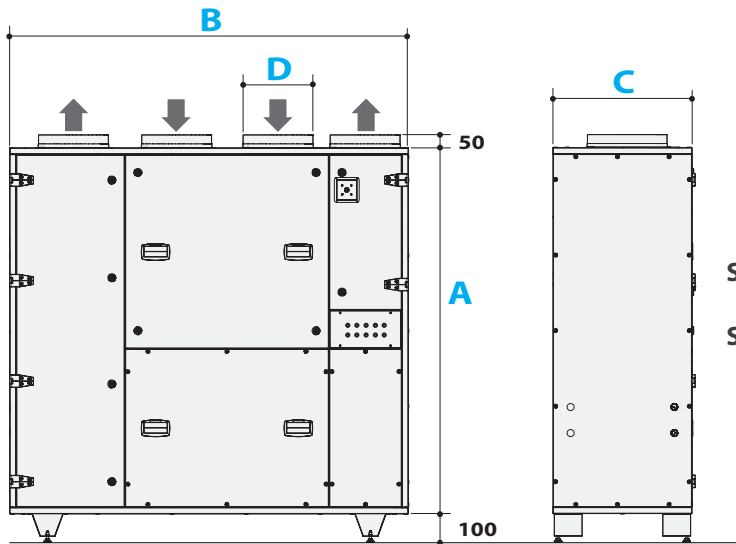

**SIZE 3-4:** unit with one section, B

**SECTION B:** heat recuperator + electrical panel + supply

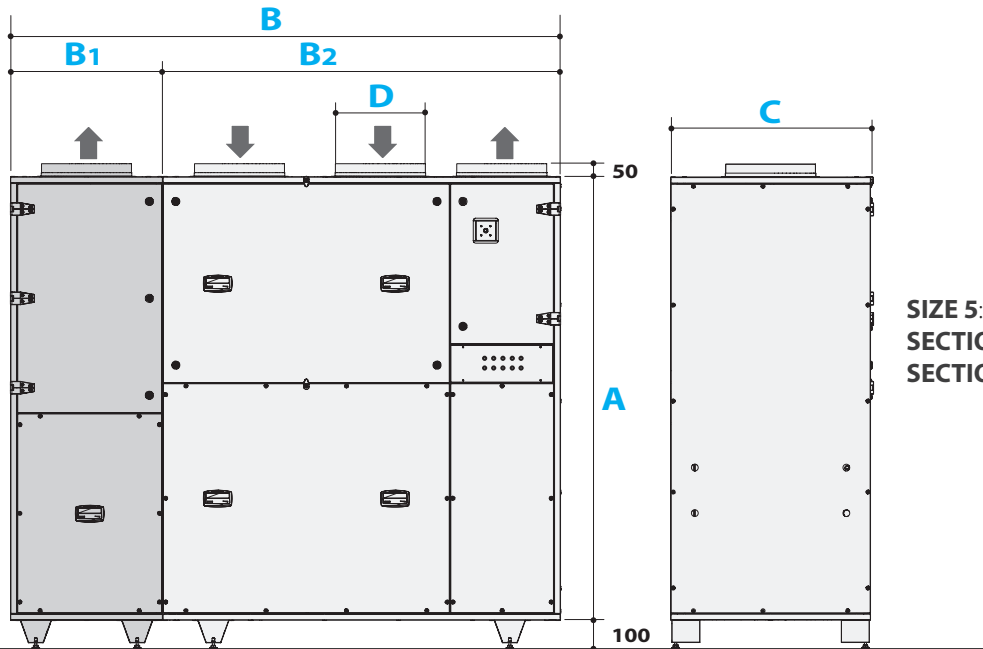

**SIZE 5:** unit with two sections, B1 and B2

**SECTION B1:** supply

**SECTION B2:** heat recuperator + electrical panel

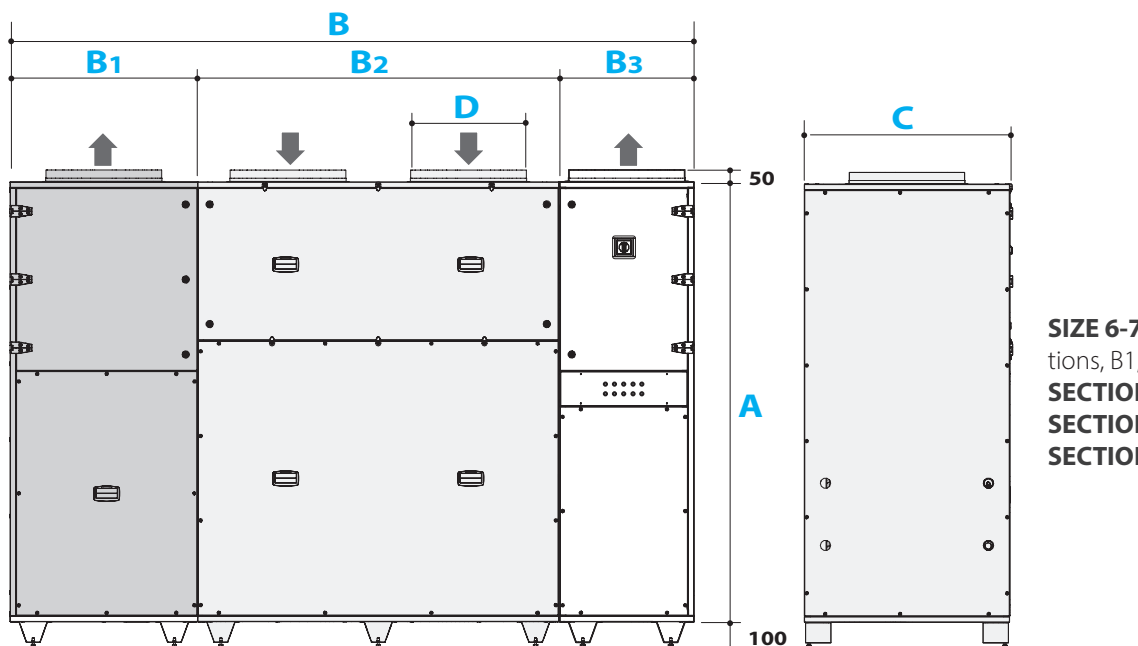

**SIZE 6-7:** unit with three sections, B1, B2, B3

**SECTION B1:** supply

**SECTION B2:** heat recuperator

**SECTION B3:** electrical panel

(mm)

# Safety measurements

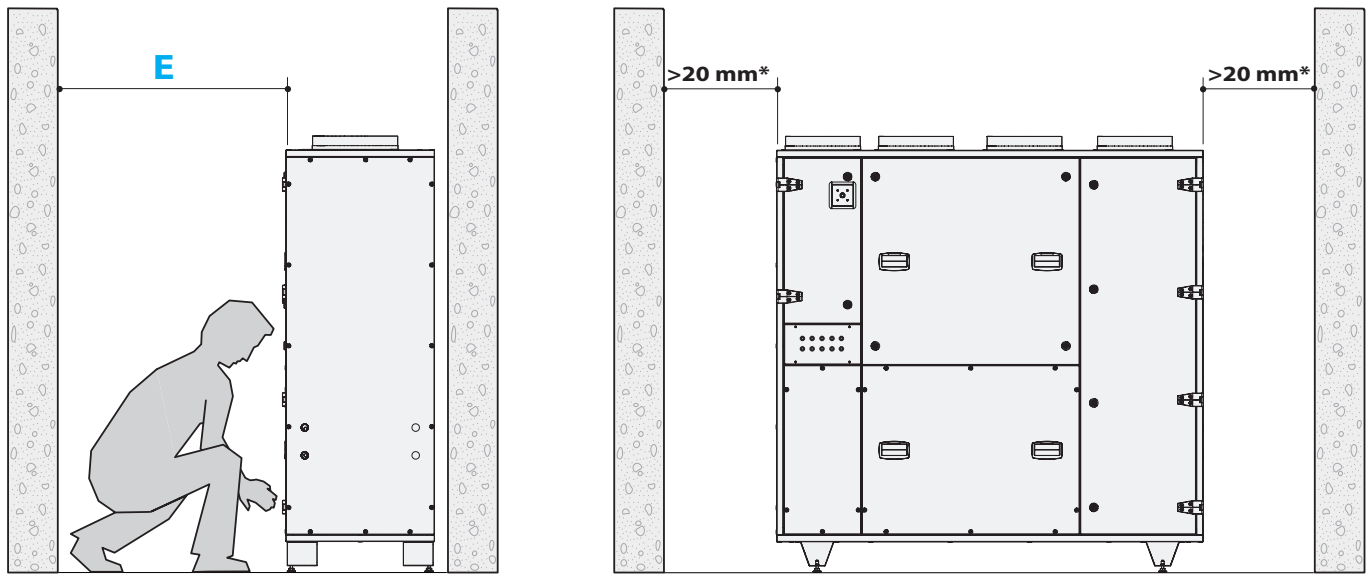

		SIZE					
		u.m.	3	4	5	6	7
Height	<b>A</b>	mm	1450	1450	1750	1700	1900
Length	<b>B</b>	mm	1580	1650	2170	2620	2950
	<b>B1</b>	mm	-	-	600	480	580
	<b>B2</b>	mm	-	-	1570	1430	1560
	<b>B3</b>	mm	-	-	-	710	810
Width	<b>C</b>	mm	550	790	790	790	890
Duct collar diameter	<b>D</b>	mm	250	315	355	400	500
Operating space in front of the unit	<b>E</b>	mm	850	1100	1100	1100	1200

\* without cooling coil

# Summary of unit operation

## RH VERSION UNITS

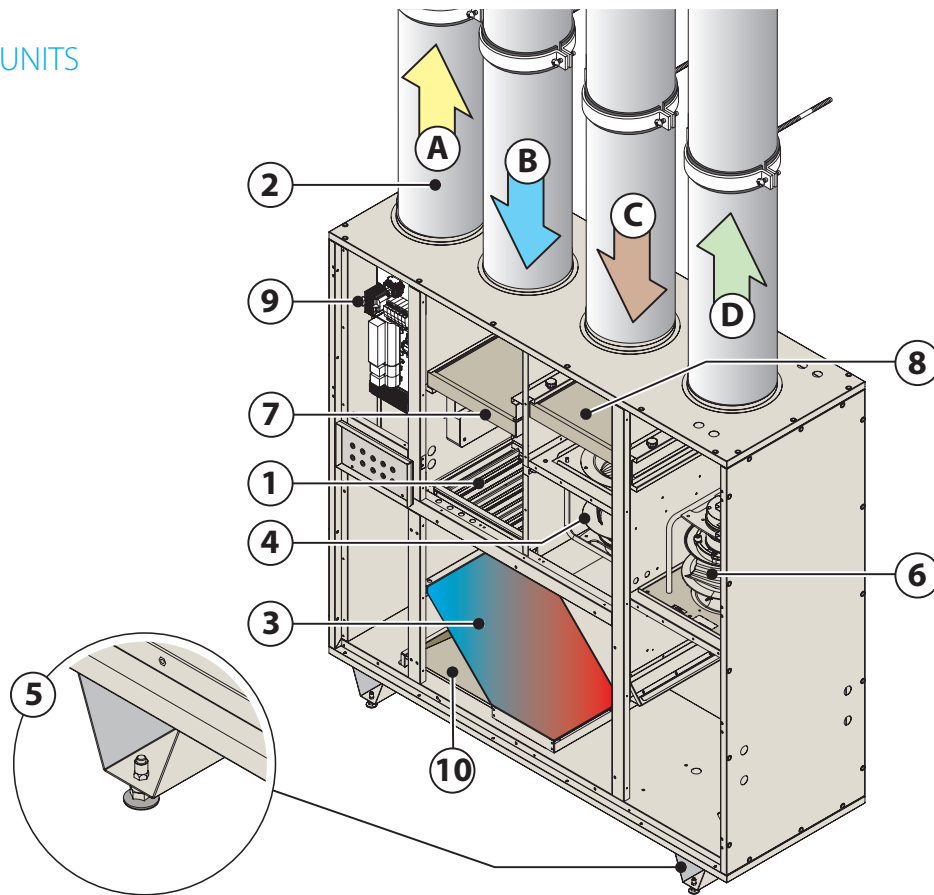

## LH VERSION UNITS

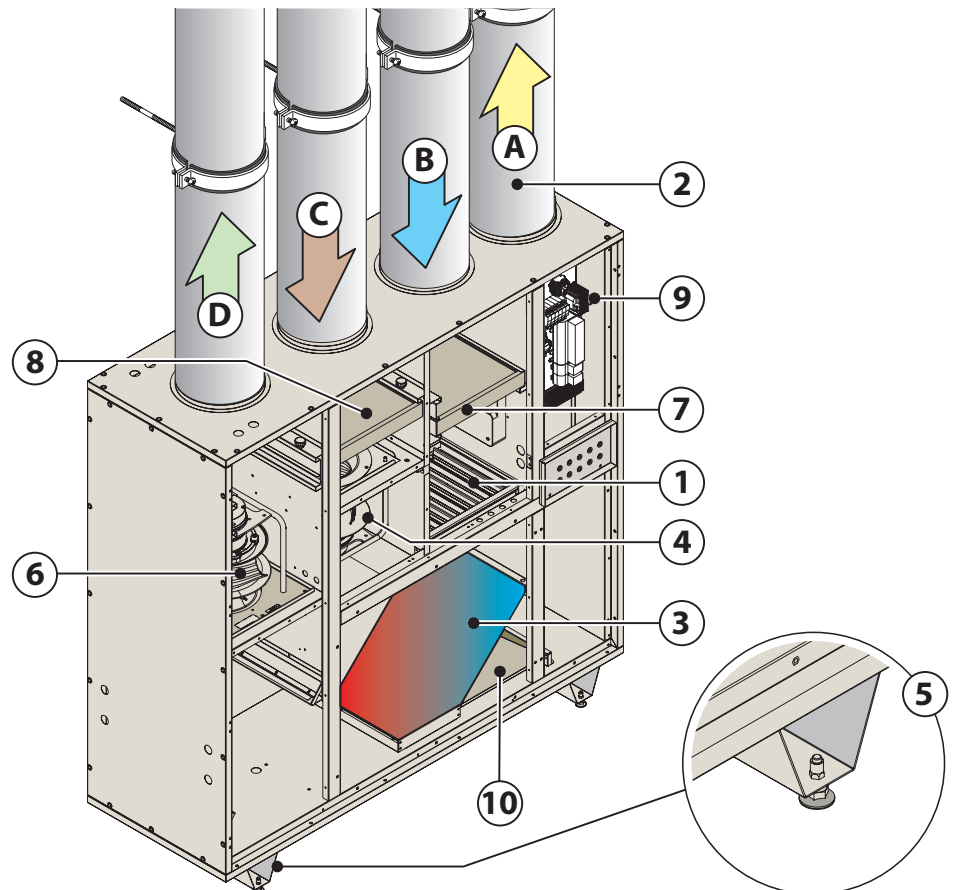

## 2 Air flows in the unit

## 2 CAPTION

- |  |               |
|--|---------------|
| ① By-pass damper                         | Ⓐ Exhaust air |
| ② Duct                                   | Ⓑ Outside air |
| ③ Plate/ heat exchanger                  | Ⓒ Return air  |
| ④ Return fan                             | Ⓓ Supply air  |
| ⑤ V-shaped supports with adjustable feet |               |
| ⑥ Supply fan                             |               |
| ⑦ ePM1 50% (F7) supply filter            |               |
| ⑧ ePM10 75% (M5) return filter           |               |
| ⑨ Electrical panel                       |               |
| ⑩ Condensate drain pan                   |               |

POS.	COMPONENT NAME	CONSTRUCTION MATERIAL
7- 8	Filter	Galvanised steel frame, fibreglass filter unit
2	By-pass damper	Aluzinc
3	Heat exchanger	Aluminium
4- 6	Fan assembly	Steel frame, composite impeller
5	V-shaped supports with adjustable feet	Galvanized steel

# 3 Receipt of the packages



Handle the equipment following the Manufacturer's instructions on the packaging and in this manual.  
Always use personal protective equipment.

The means and method of transport must be chosen by the transport operator according to the type, weight and size of the unit. If necessary, draw up a "safety plan" to guarantee the safety of the people directly involved.

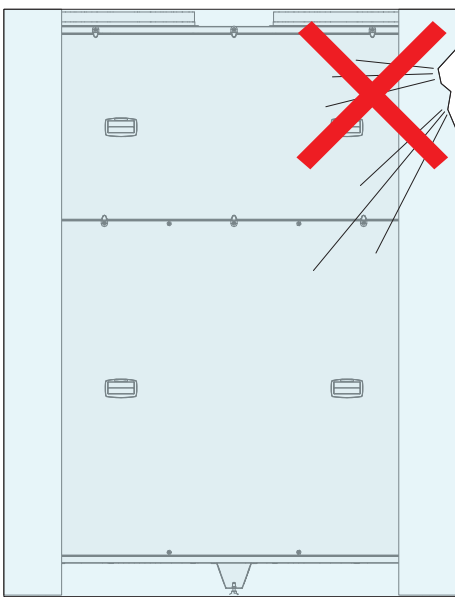

Upon receipt of the unit check the integrity of the packaging and the amount of parcels sent:

A) There is visible damage/one or more package is missing:

**do not** install, but **promptly** notify the Manufacturer and the carrier that made the delivery.

Alternatively you can accept the shipment "subject to verification": this will make it possible to open the cartons and check if the internal components are indeed damaged. In the latter case, as noted previously, **promptly** notify the Manufacturer and the carrier that made the delivery.

Before opening the packages, it is recommended to take good quality pictures to document the damage.

B) There is NO visible damage: move the unit to the site of installation.

# 4 Transport



The packages must be transported with a transpallet or a forklift, suitable for the weight and size of the package. The choice of the most appropriate means and way remains the responsibility of the transport operator.

3

The figure shows the correct forking direction of the unit according to the size and the sections; always make sure to keep the centre of gravity of the load balanced.



The operating area must be perfectly free from objects or people not involved in the transport.



Transport the equipment carefully, in perfect psycho-physical shape, avoiding sudden manoeuvres and equipped with personal protective equipment (gloves, safety shoes, etc.).



SIZE 3

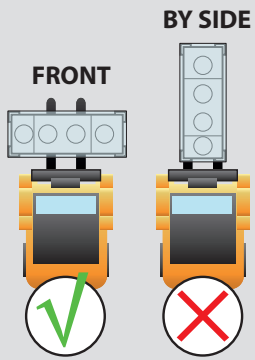

SIZE 4

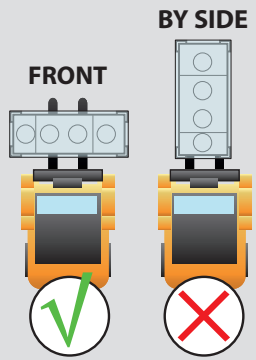

SIZE 5

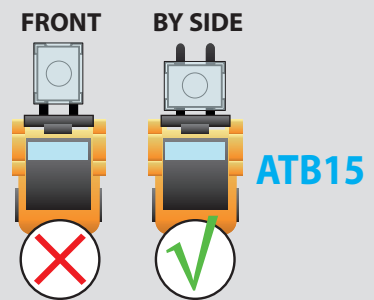
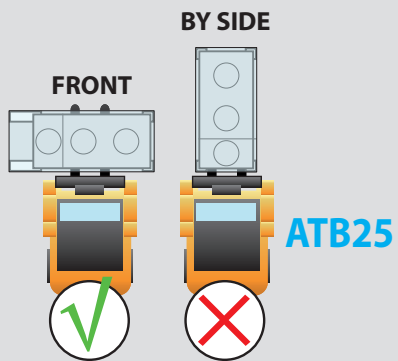

SIZE 6-7

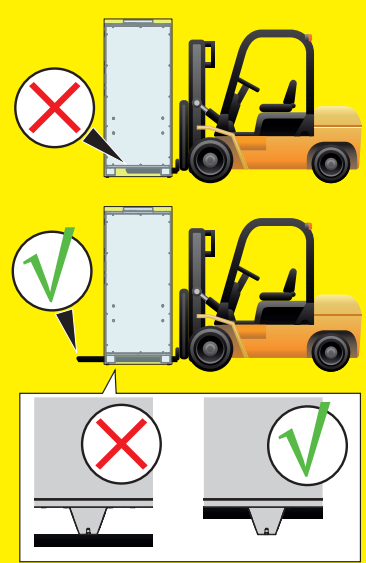
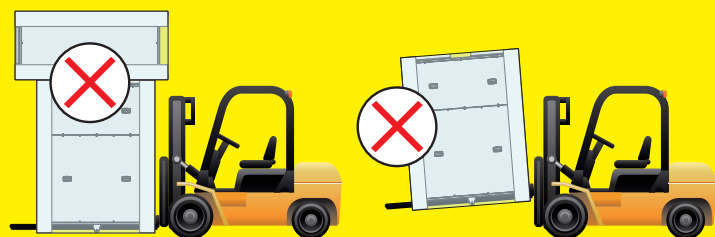
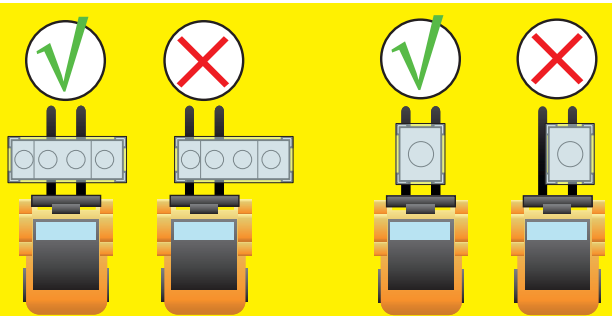
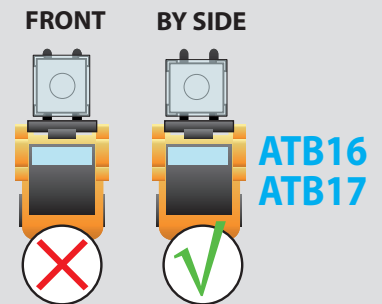
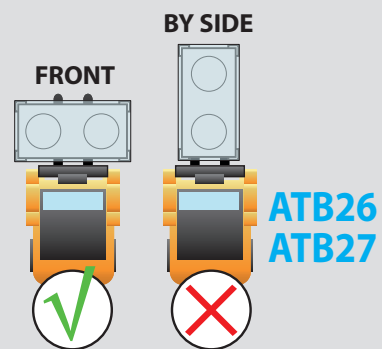
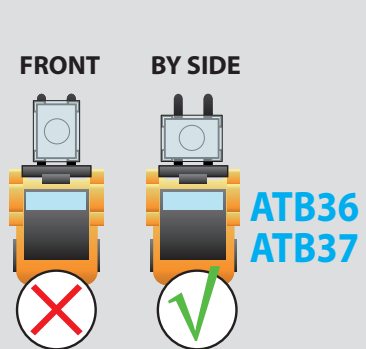

Lift the unit with the forks resting on its bottom, not on the foot brackets

**3** Correct transport of the packed unit



# 5 Unpacking and integrity check

We recommend the equipment be unpacked after moving it to its installation location and only when it is to be installed. This operation must be performed using personal protection equipment (i.e., gloves, safety shoes, etc.).

 Do not leave the packing unattended: it is potentially harmful to children and animals (suffocation hazard).

 Some packing materials must be kept for future use (wooden crates, pallets, etc.), while those that cannot be reused (i.e., polystyrene, strapping, etc.) must be disposed of in compliance with the regulations in force in the country of installation: this will protect the environment!

## After unpacking

After unpacking, check the received contents:

- **Installation and operation manual (IOM)**
- **Wiring diagram**
- **Declaration of conformity**

Check therefore that you have received all the components and that they are undamaged. In case of damaged or missing parts:

- **do not move, install or repair** damaged components and the unit in general.
- **take quality photos** to document the damage.
- **Find the serial number plate** on the unit and note the unit's serial number;
- **Immediately** notify the carrier that delivered the unit;
- **promptly** contact the Manufacturer (keep available the serial number of your unit).

 Please note that complaints or claims of damage reported after 10 days of receipt of the unit cannot be accepted.

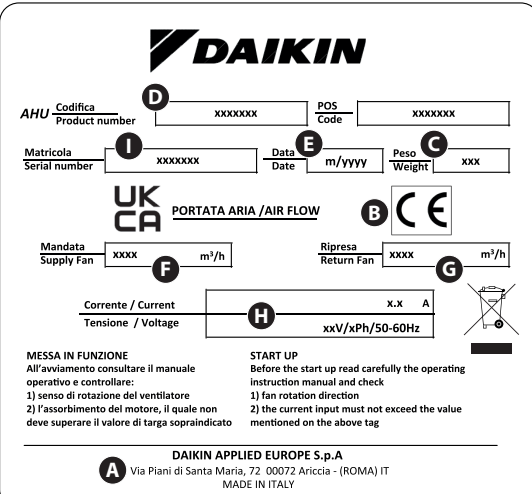

**DAIKIN**

AHU Codifica / Product number: D xxxxxxxx POS Code: xxxxxxxx

Matricola / Serial number: I xxxxxxxx Data / Date: E m/yyyy Peso / Weight: C xxx

UK CA PORTATA ARIA / AIR FLOW B CE

Mandata / Supply Fan: F xxxxx m<sup>3</sup>/h Ripresa / Return Fan: G xxxxx m<sup>3</sup>/h

Corrente / Current: H x.x A Tensione / Voltage: xxV/xPh/50-60Hz

MESSA IN FUNZIONE: All'avviamento consultare il manuale operativo e controllare: 1) senso di rotazione del ventilatore 2) l'assorbimento del motore, il quale non deve superare il valore di targa sopraindicato

START UP: Before the start up read carefully the operating instruction manual and check: 1) fan rotation direction 2) the current input must not exceed the value mentioned on the above tag

DAIKIN APPLIED EUROPE S.p.A. Via Piani di Santa Maria, 72 00072 Ariccia - (ROMA) IT MADE IN ITALY

- A: Manufacturer's name and data  
DAIKIN APPLIED EUROPE S.P.A.  
Via Piani di Santa Maria, 72 - 00072 Ariccia (Roma) - Italy  
Tel: (+39) 06 93 73 11 - Fax: (+39) 06 93 74 014
- B: CE markings
- C: Unit weight
- D: Code and POS
- E: Date of manufacture
- F: Supply air flow
- G: Return air flow
- H: Electrical specifications (frequency, number of phases, absorption in plate conditions)
- I: Unit serial number

# Product nomenclature

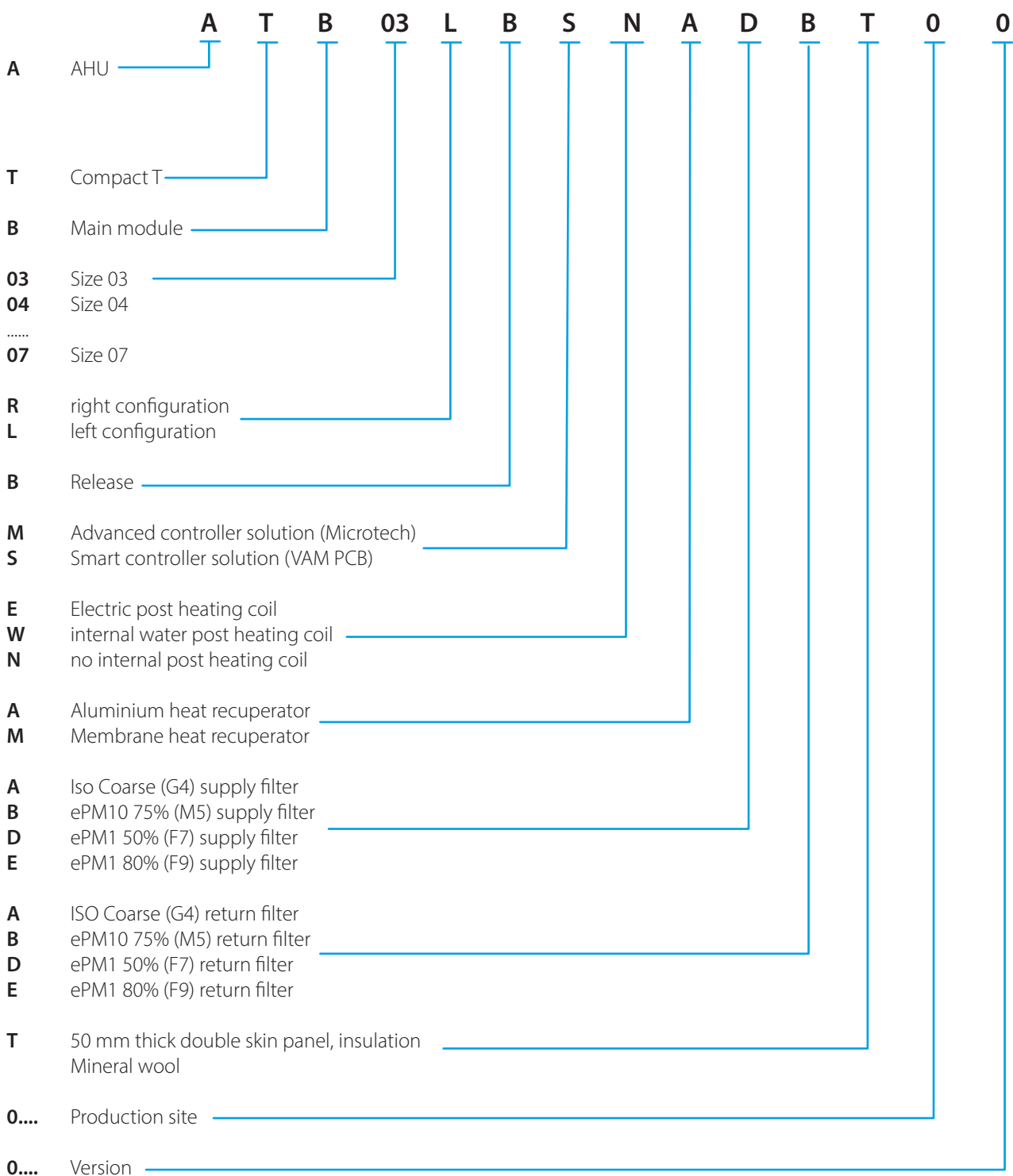

# Storage waiting for installation

**4** Waiting for the installation, the components of the unit and the relative documents must be stored in an area that:

- is dedicated exclusively to the storage of the units;
- is protected from the weather (preferably prepare a closed area), with adequate temperature and humidity.
- Is accessible only to operators tasked with the assembly.
- Can support the weight of the equipment (check the load rating) and has a stable floor.
- is free from other components, especially if they are potentially explosive/incendiary/toxic.

If you cannot proceed with the installation straight away:

- check periodically that the above-mentioned conditions about the storage area are guaranteed;
- cover the unit with a sheet;
- always provide an insulating base (e.g., wood blocks) between the floor and the unit itself.

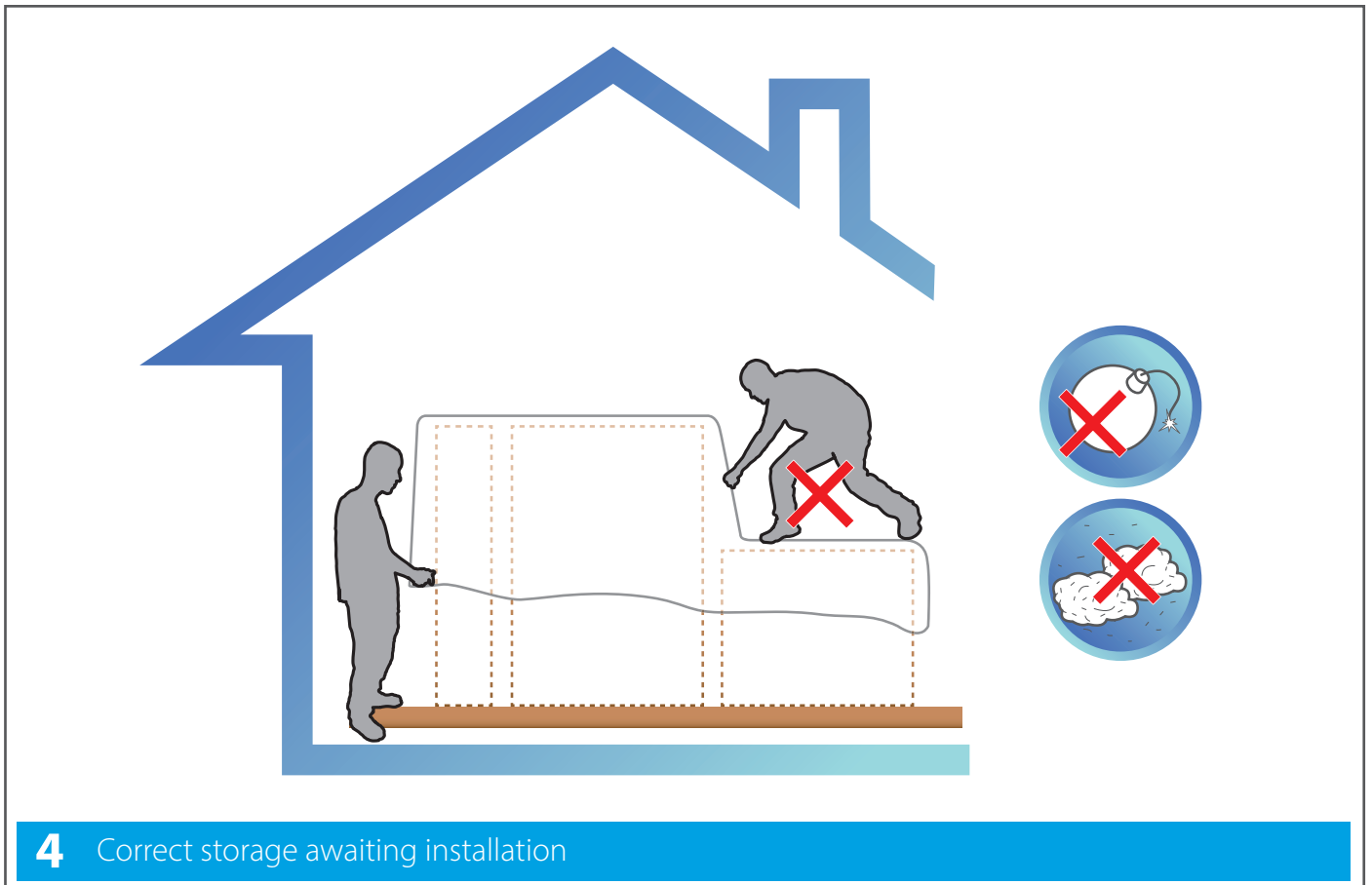

Any movement carried out after unpacking must be done with the doors closed. Do not move the units by pulling on the doors, if present, the uprights or other protruding parts that are not an integral part of the structure.



**Do not step on the units!**

# 6 Installation



All installation, assembly, electrical connections to the mains and extraordinary maintenance must be performed **only by qualified personnel authorised by the Retailer or Manufacturer**, in compliance with the regulations in force in the country the equipment is to be used and the standards on the systems and safety in the workplace.



During installation, the area must be free from people and objects not used for the assembly.



Before starting, make sure you have all the necessary equipment. Use only equipment that is in good condition and undamaged.



## Installation procedure

Before installation, read the safety instructions on the first pages of this manual. Contact the Manufacturer if any points are unclear or not perfectly understandable. A check mark next to each step will help to confirm complete and proper installation.

- PHASE 0:** TRANSPORT OF THE UNITS TO THE PLACE OF INSTALLATION
- PHASE 1:** UNIT CHECK AND SETTINGS
- PHASE 2:** FEET ASSEMBLY
- PHASE 3:** FITTING THE GASKET (ONLY SIZES 05-06-07)
- PHASE 4:** MECHANICAL UNION BETWEEN SECTIONS (ONLY SIZES 05-06-07)
- PHASE 5:** ELECTRICAL WIRING BETWEEN SECTIONS (ONLY SIZES 05-06-07)
- PHASE 6:** ROOM THERMOSTAT CONNECTION
- PHASE 7:** ELECTRICAL CONNECTIONS
- PHASE 8:** CONNECTION TO A DRAIN
- PHASE 9: AERAULIC CONNECTIONS (SUGGESTED PHASE)**
- PHASE 10:** TESTING

After installation store this manual and the assembly sheet that accompanied the unit in a place that is dry and clean. This way it will be accessible to operators in the future who need to consult it. Do not remove, tear out or write on any part of this manual besides the spaces set aside for notes:



## PHASE 0: TRANSPORT OF THE UNITS TO THE PLACE OF INSTALLATION

Transport the units until they reach the place intended for installation.



5

The units must be transported with a transpallet or a forklift, suitable for the weight and size of the package. The choice of the most appropriate means and way remains the responsibility of the transport operator.

The figure on page 17 shows the correct forking direction of the unit according to the size and sections; always make sure to keep the centre of gravity of the load balanced.



The operating area must be perfectly free from objects or people not involved in the transport.



Transport the equipment carefully, avoiding sudden manoeuvres and equipped with personal protective equipment (gloves, safety shoes, etc.).

See page 17 to know the correct forking direction of the unit.

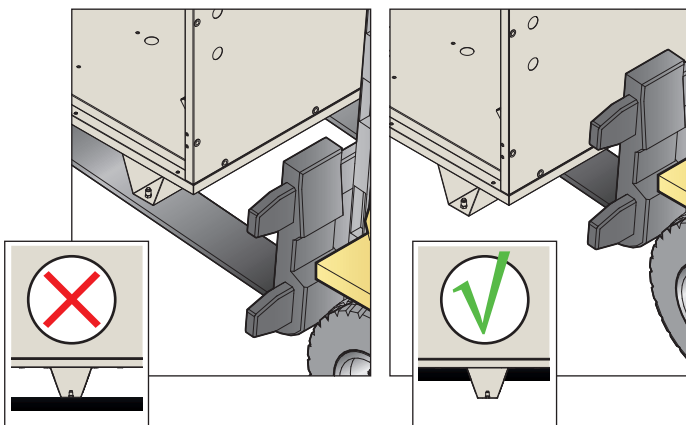
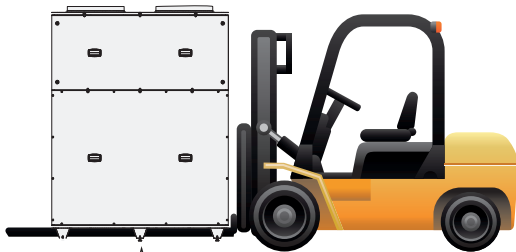
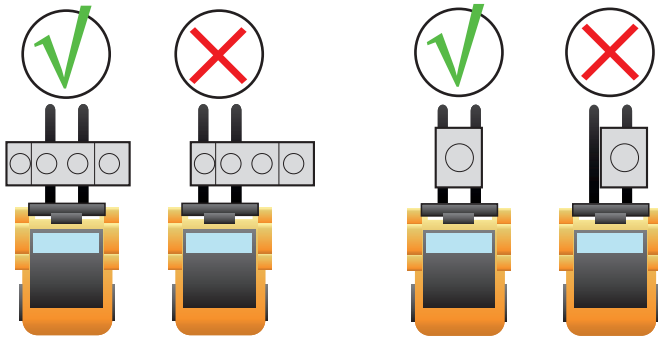

Lift the unit with the forks resting on its bottom, not on the foot brackets

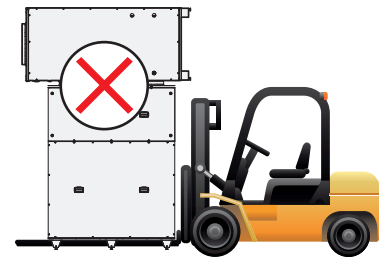

5 Correct transport of the unit

## PHASE 1: UNIT CHECK AND SETTINGS

Check that all components supplied are present

		SIZE				
		3	4	5	6	7
Installation and operation manual (IOM)		1	1	1	1	1
Wiring diagram		1	1	1	1	1
Declaration of conformity		1	1	1	1	1
Adjustable feet and hex nut		4	4	8	14	14
Door release key		1	1	1	1	1
Stainless steel washer		-	-	16	32	40
Split spring washer		-	-	8	16	20
M6x70 hex bolt		-	-	8	16	20
M6 hex nut		-	-	8	16	20
Gasket		-	-	1 roll	1 roll	1 roll

**6** Check that the following have been planned at the installation site:

- A** an **electrical system** compliant with current regulations and with specifications that meet the needs of the unit;
- B** a **floor or wall drain, with siphon**, connected to the sewer system;
- C** an **aeraulic system** (ducts for the air to be conveyed to the rooms).

Check that the **floor** of the place chosen for installation is:

- perfectly **flat and without any roughness**;
- vibration **resistant**;
- **able to support the weight of the equipment** considering an appropriate safety margin (see technical data table on page 10).

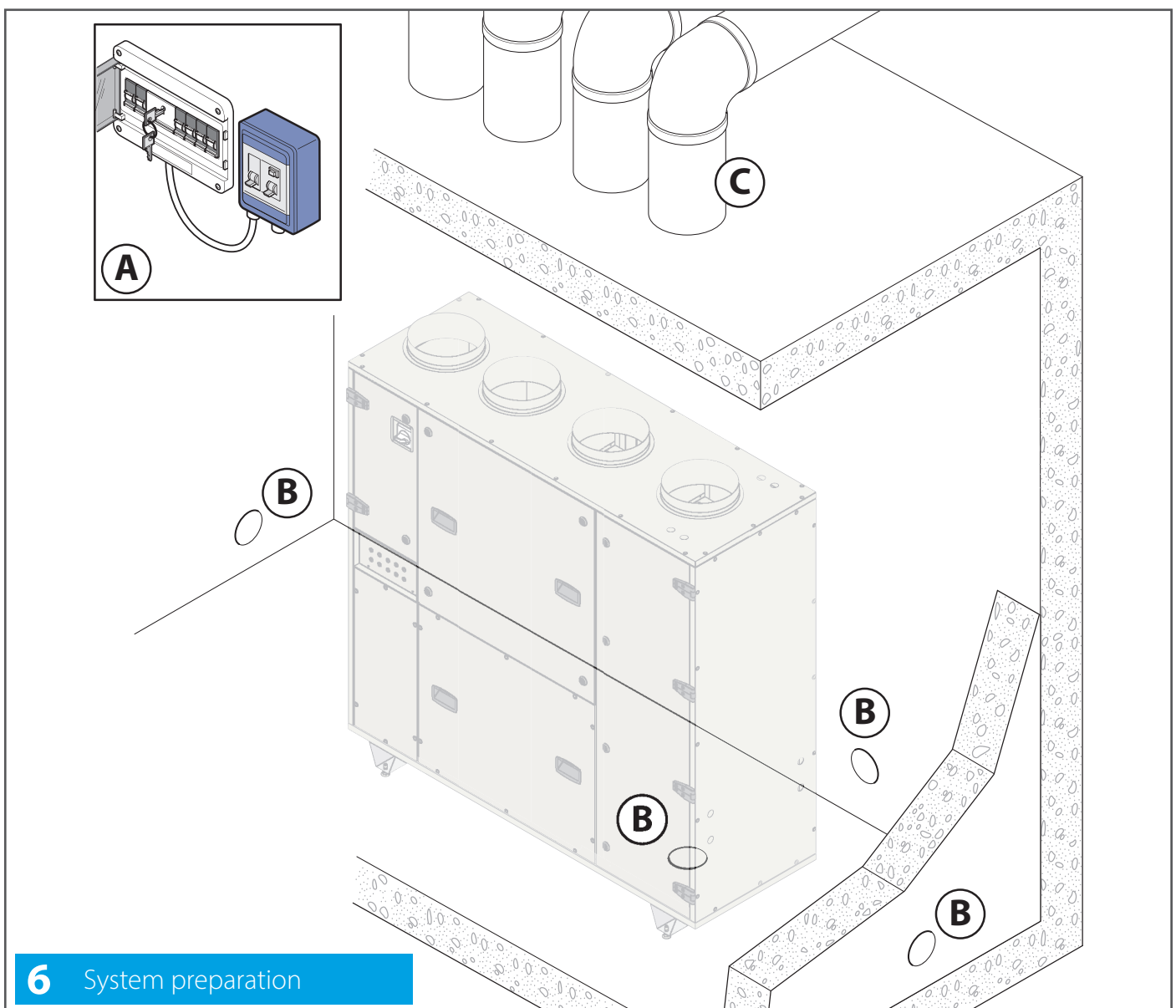



## PHASE 2: FEET ASSEMBLY

**7** Before positioning the unit, assemble the provided feet; do not use other types of supports or try to modify the feet supplied.

 To attach the feet **DO NOT tilt the unit or turn it over.**

With a transpallet or with a forklift, suitable for the weight and dimensions of the unit, lift it as little as necessary to carry out the assembly of the feet; during lifting, **NEVER position yourself under the unit itself.**

 It remains the responsibility of the transport operator to choose the most appropriate means and way for lifting. The figure on page 17 shows the correct forking direction of the unit according to the size and sections; always make sure to keep the centre of gravity of the load balanced.

After fitting the feet, check that the unit is perfectly level; if this condition is not verified, rotate the feet until it is obtained (be careful not to unscrew the feet too much, risk of instability).

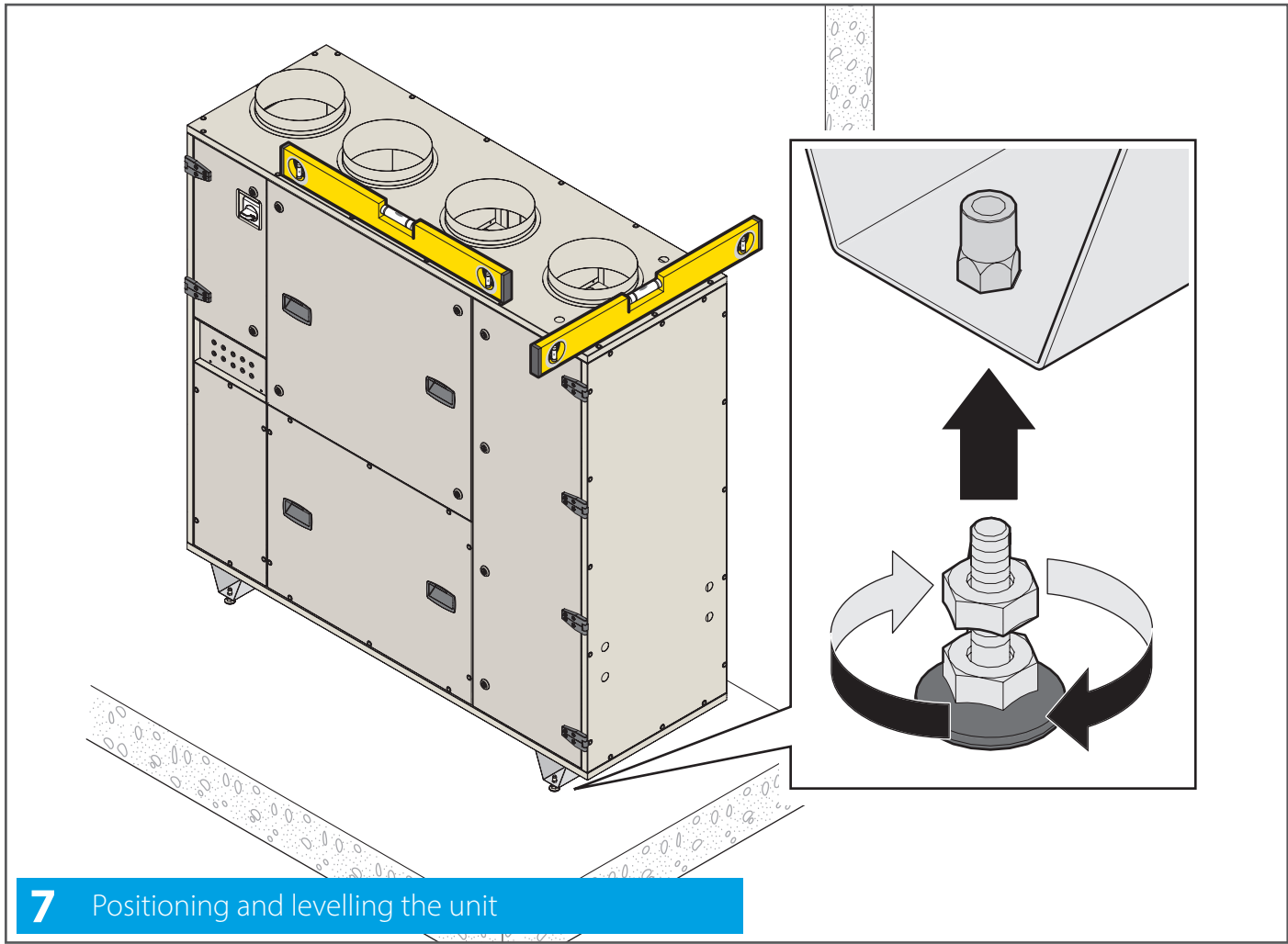

### PHASE 3: FITTING THE GASKET (ONLY SIZES 05-06-07)

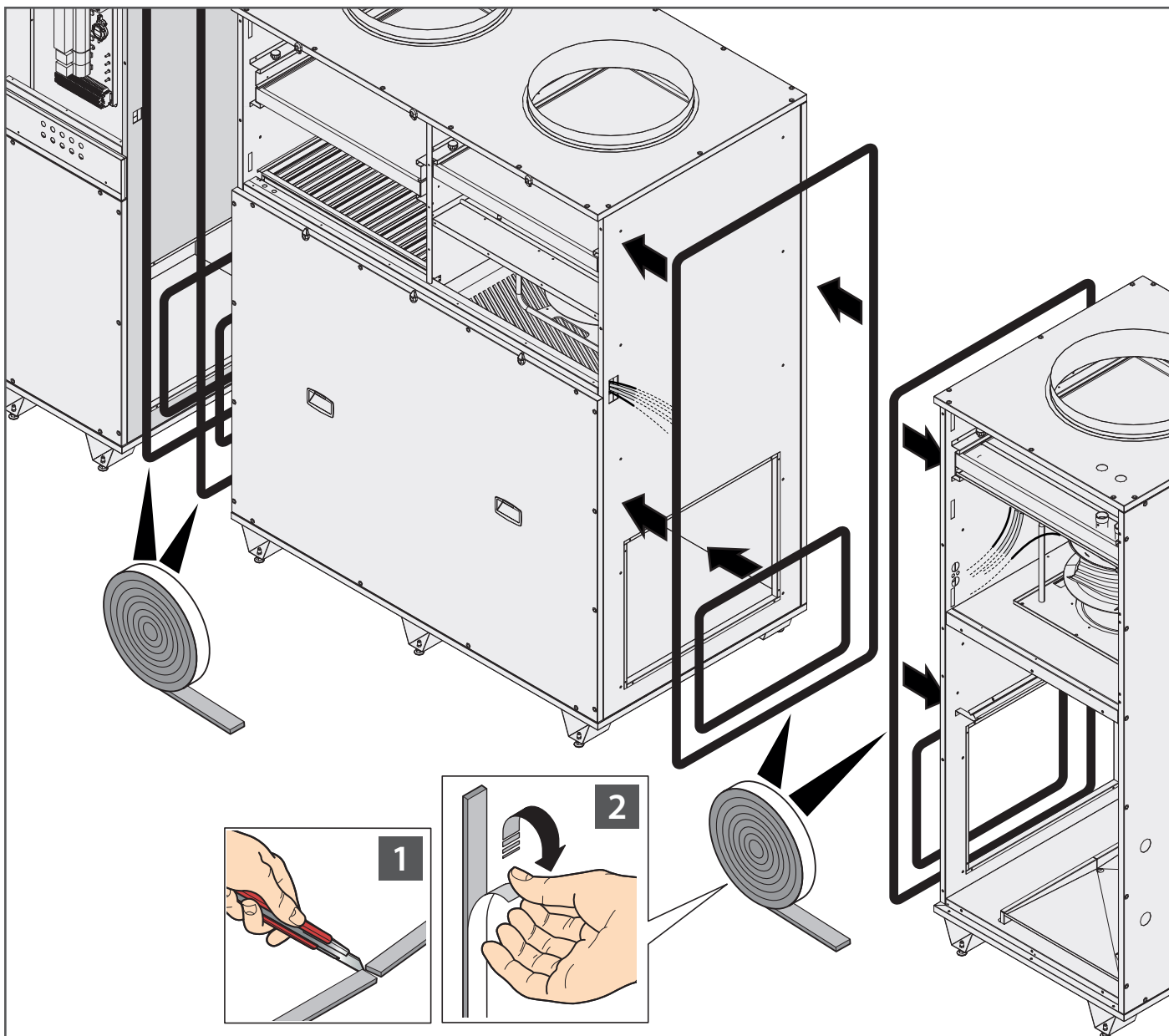

**SIZE 5**

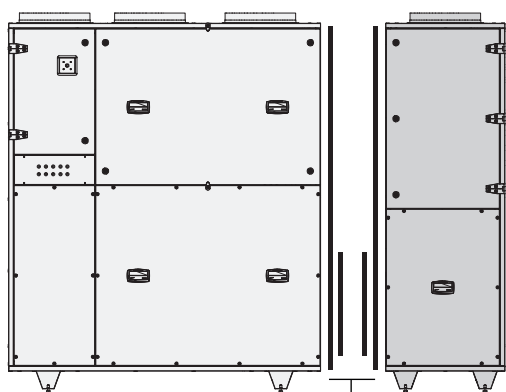

gaskets

**SIZES 6-7**

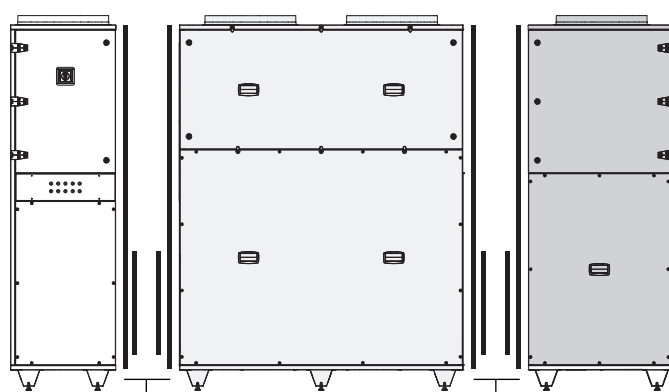

gaskets

gaskets

## 8 SIZES 05-06-07, gasket application

## PHASE 4: MECHANICAL UNION BETWEEN SECTIONS (ONLY SIZES 05-06-07)

**9** Pass all the cables through the holes provided and then join the various sections as shown in the figure. Size 5 has two sections, sizes 6 and 7 have three sections.

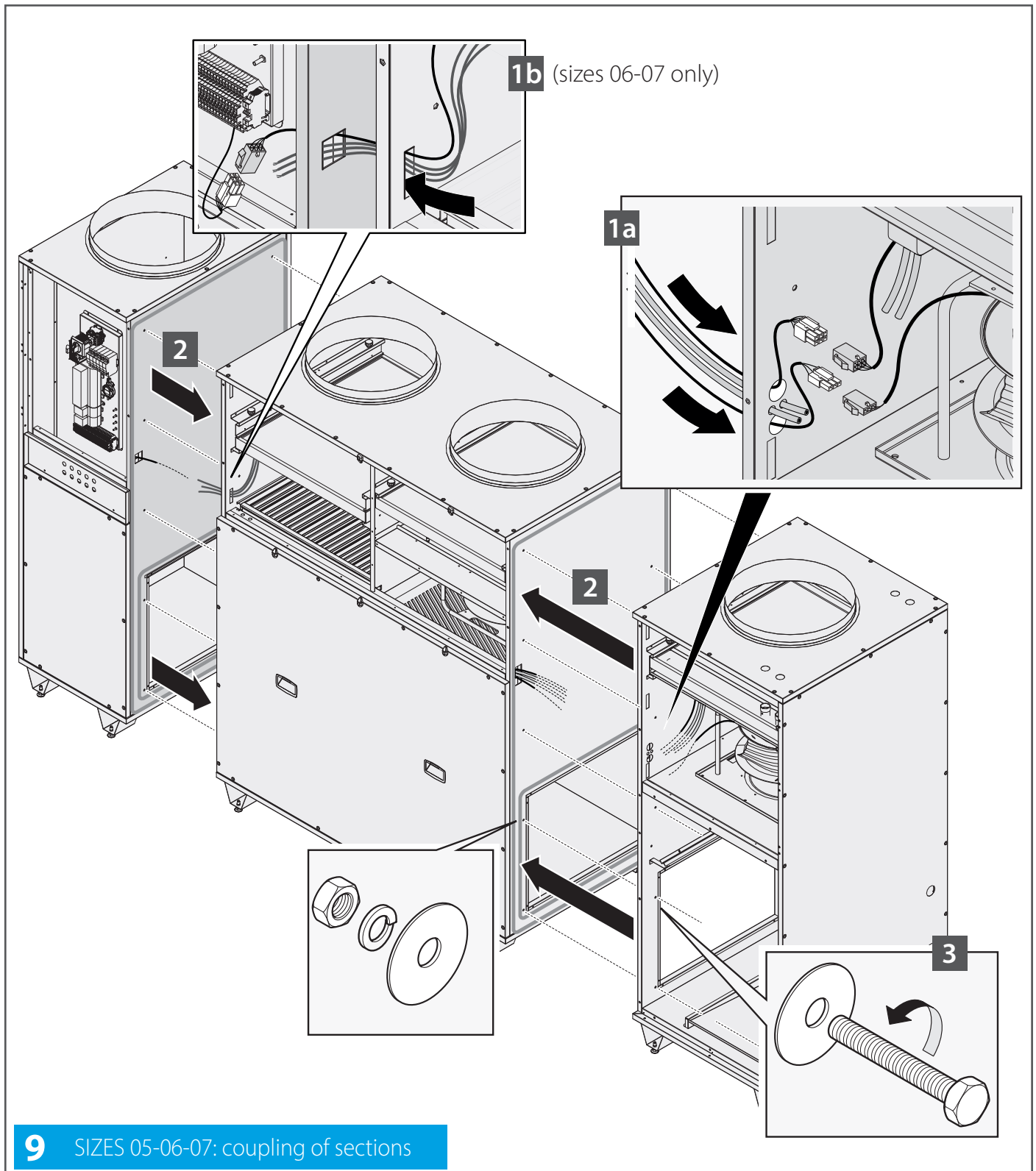

## PHASE 5: ELECTRICAL WIRING BETWEEN SECTIONS (ONLY SIZES 05-06-07)

Make the connections shown in the figure.

To facilitate understanding, the cables have been schematized outside the sections, in reality the connectors are located inside the unit as shown in the previous figure.

### 10 SIZE 5

- 1x - BUS connector 6-pole connector;
- 1x - fan supply 3-pole connector;
- 2x - tapping points plugs on the return air of the fan.

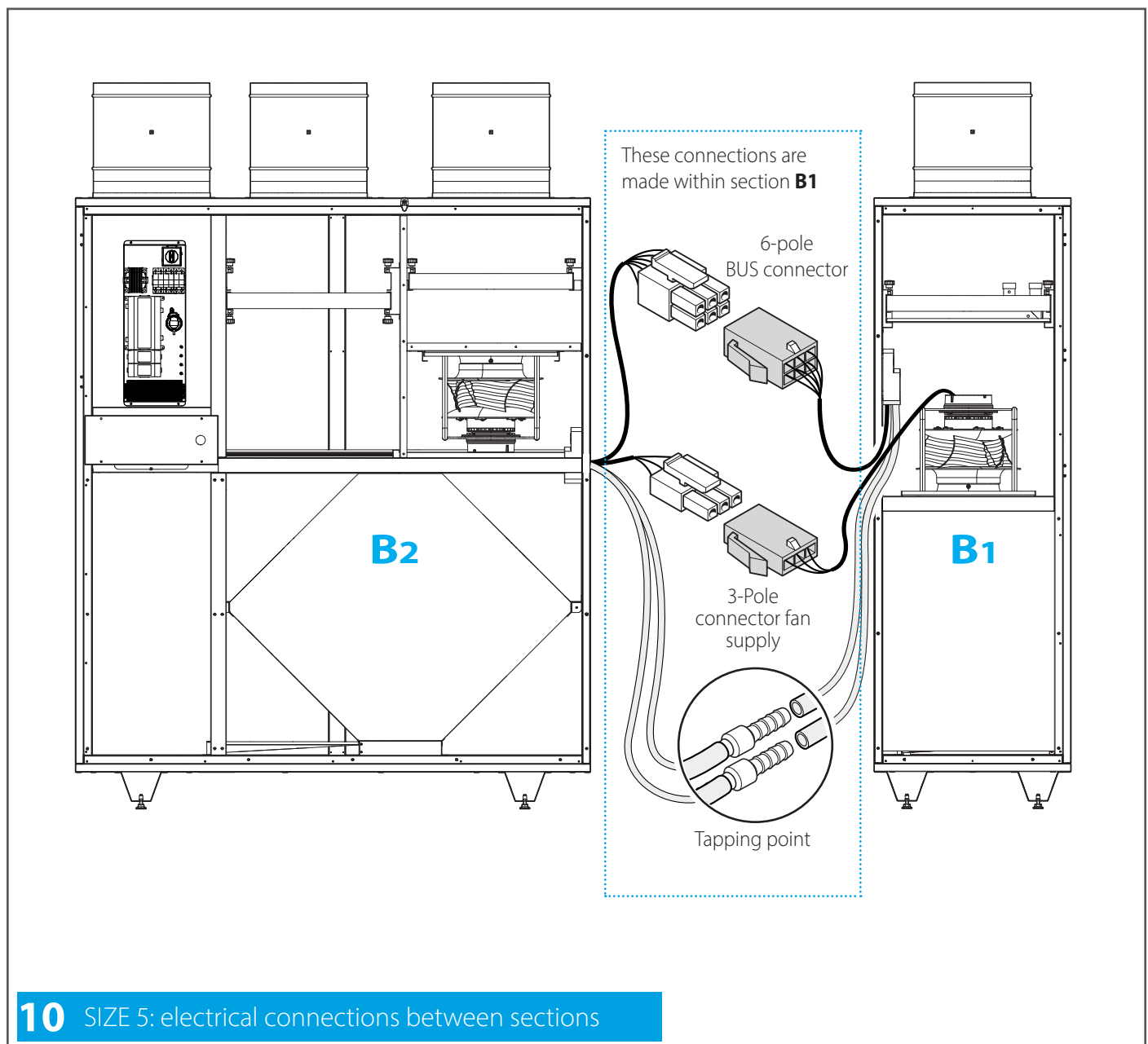

## 11 SIZES 6-7

Make the connections shown in the figure.

To facilitate understanding, the cables have been schematized outside the sections, in reality the connectors are located inside the unit as shown in the previous figure.

- 2x - 6-pole BUS connector;
- 1x - fan supply 3-pole connector;
- 2x - tapping points plugs on the return air of the fan.
- connection cables to the electrical panel.

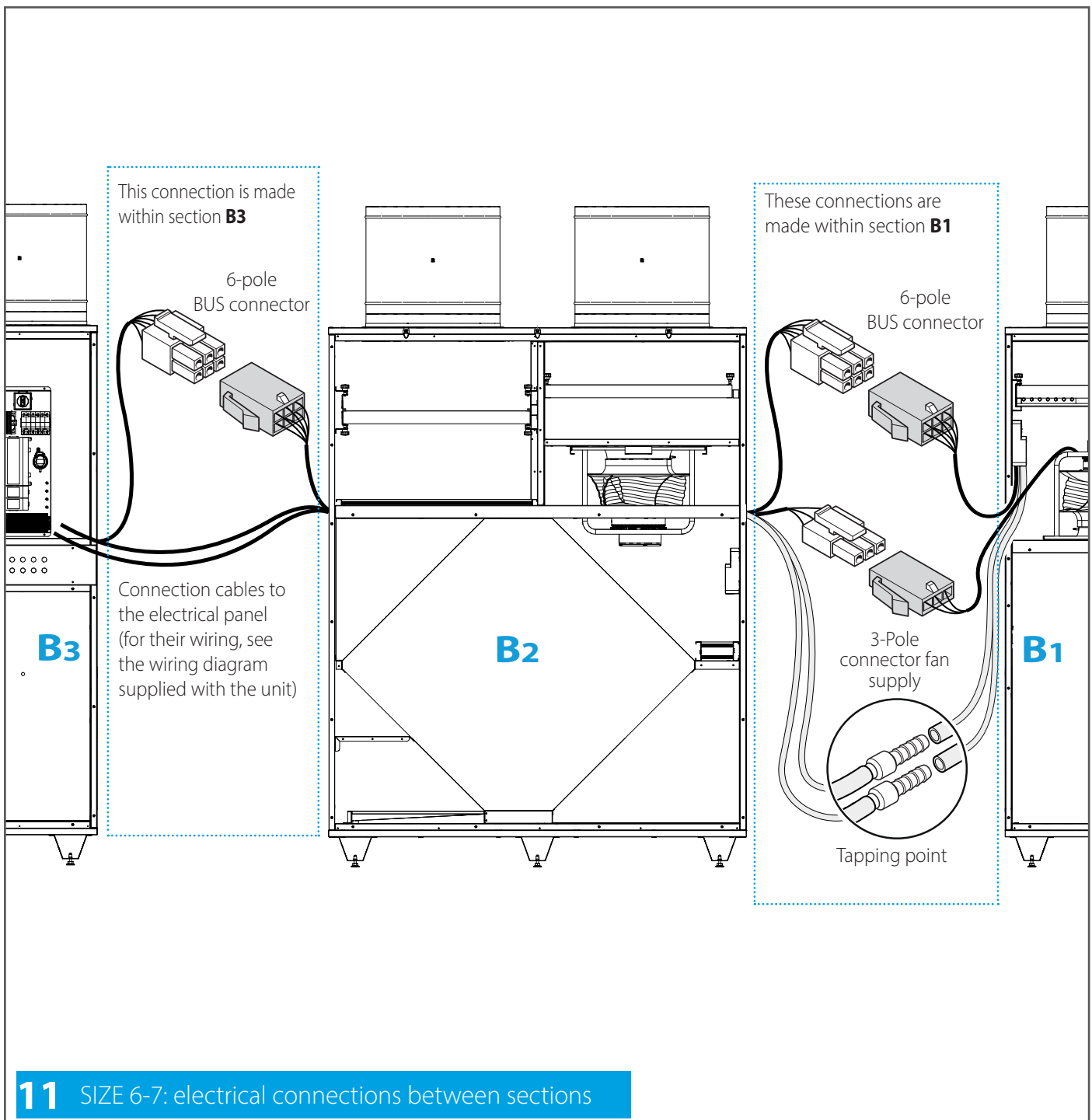

## PHASE 6: ROOM THERMOSTAT CONNECTION

**12** The unit can be supplied with a room thermostat which must be connected as shown in the figure.

### 12 Thermostat connection

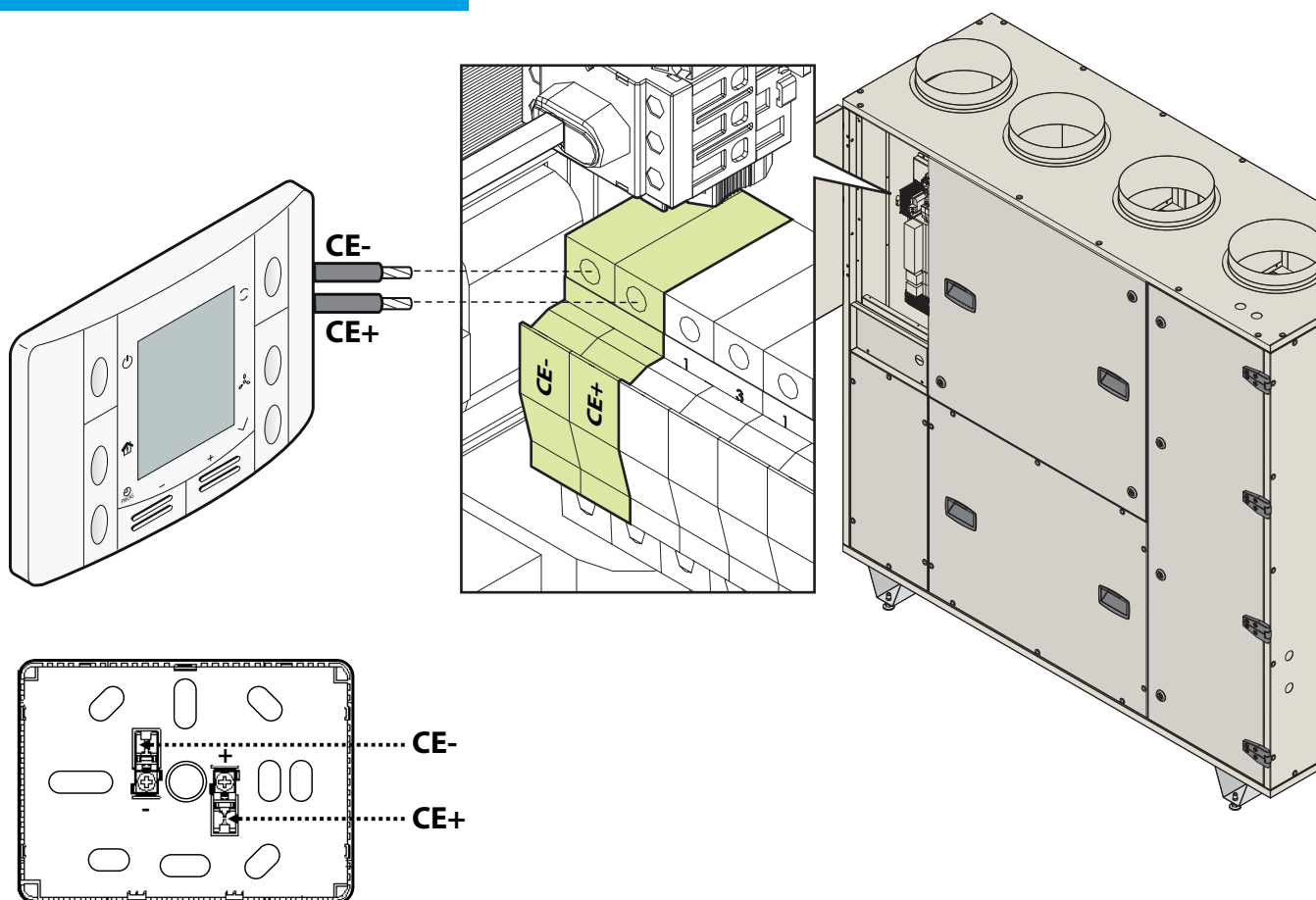

## PHASE 7: ELECTRICAL CONNECTIONS

13



For the **power supply** it is necessary to connect the unit to an electrical panel in compliance with current regulations.



**Always refer to the wiring diagram that is specific to the unit that you bought** (it was shipped with the unit). If it is not on the unit or has been lost, contact the salesperson of reference who will send a copy (specify the unit's serial number).

Before connecting the electrical panel, make sure that:

- the voltage and frequency of the network correspond to the parameters of the unit.
- the electrical system being connected has sufficient capacity to supply the nominal electric power of the unit to be installed and meets current regulations.



The electrical connection must be:

- made by qualified personnel after cutting off the facility's power supply;
- Performed in a fixed and permanent manner, without intermediate splices, in compliance with the regulations of the country of installation;
- adequate to the absorption of the unit (see technical specifications);
- provided with a functioning grounded plug. For multiple units it is necessary to connect each unit to the ground connection or combine them all with metal ties.
- preferably situated in a dedicated room, **locked** and protected from the weather. If there is also a key switch, the key must be removed when cutting the power supply and returned to its position only after finishing service operations.
- install a **16A circuit breaker system** or a system suited to the unit absorption.



During the electrical connection, make sure that **no person**, other than the one who is working on the system, has access to the electrical rooms or switches.



The actual supply voltage of the users **must not deviate more than 10%** from the normal voltage expected. Higher voltage differences cause damage to users and to the electrical system, malfunctioning of fans, noise level. It is therefore essential to check the alignment of the actual voltage values with the nominal values.

After connecting, make sure that:

- the ground connection is sufficient (using the appropriate instrument). An incorrect connection, ineffective and lacking the grounding circuit, is contrary to safety regulations and is a source of danger and can damage the components of the unit.
- the motor rotation direction is correct;
- the wiring and motor power draw are correct.

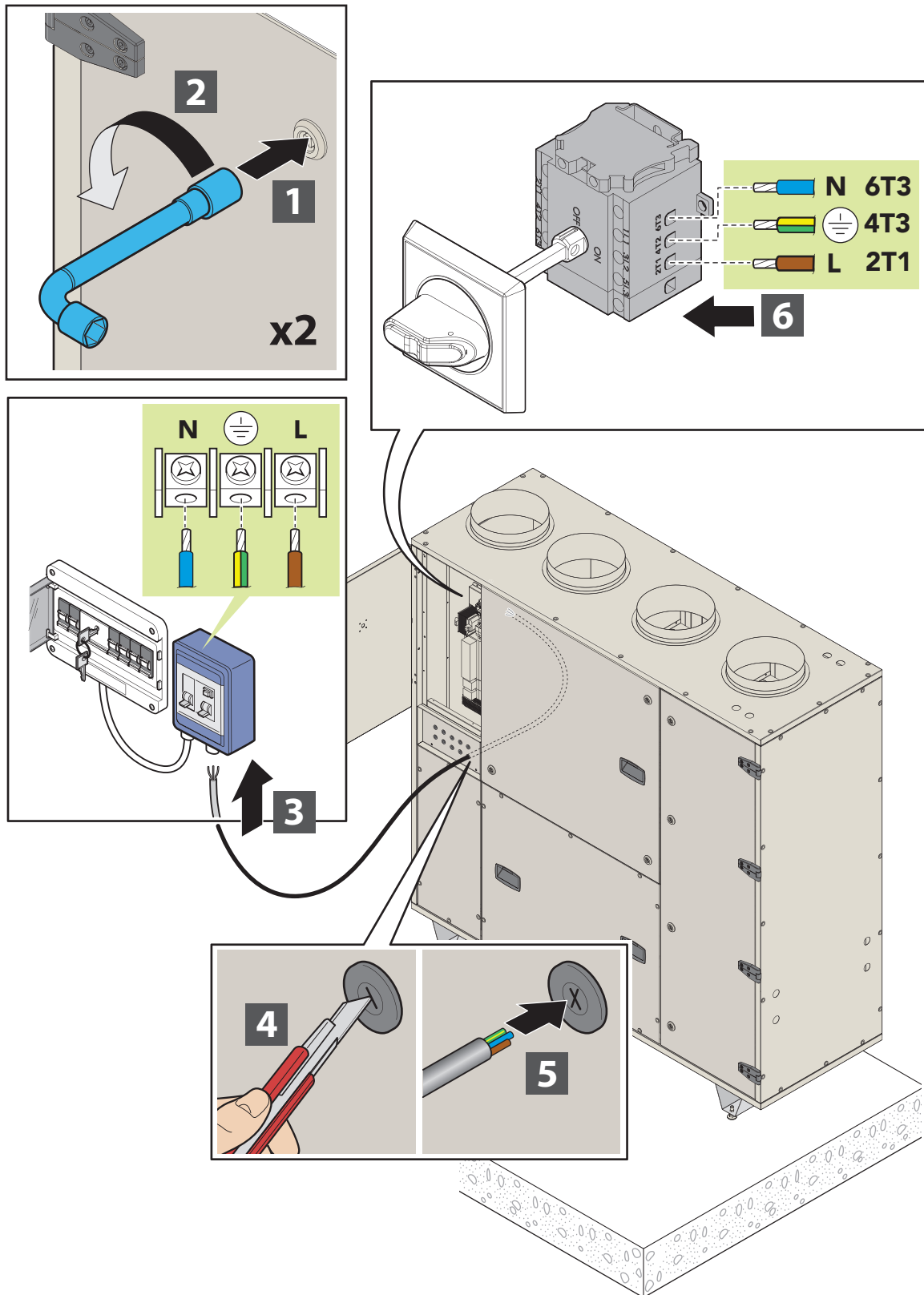

The Manufacturer is not responsible for connections made in a manner that does not comply with regulations, with the specifications of this manual, and in the event of tampering with any electrical component of the unit.

## 13 Electrical connection



## PHASE 8: CONNECTION TO A DRAIN

**14** The units are equipped with two 3/4" F drains in the lower part:

- the drain **A** empties the condensate collected from the drain pan located under the exchanger;
- the drain **B** must only be connected if an optional DX or hot/cold water coil has been installed.

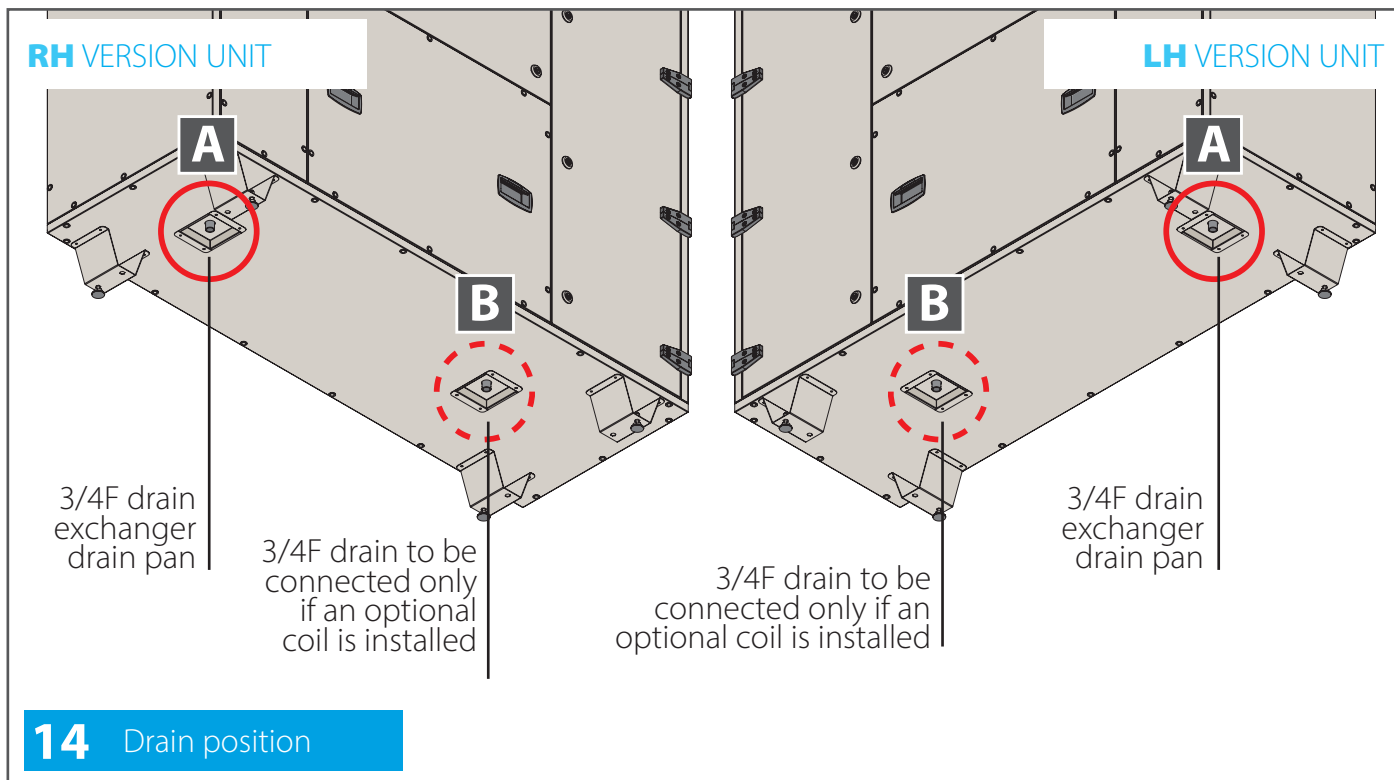

In order to absorb any recovery of air or sewage and to make the correct flow of drain water visually controllable, **each drain must be equipped with a siphon** (not supplied). To avoid overflows from the drain pan, the siphon must be equipped with **a drain** that allows the removal of the impurities that settle on the bottom; moreover, in order not to jeopardize the operation of the drain system, siphons operating under pressure must NOT be connected with others operating under depression. The choice of the type of siphon and its correct installation is the responsibility of the installer.

**15** The sewer drain can be located:

### on the side walls

- S1** distance of the unit from the walls:
- side: keep a space necessary to position a siphon (not supplied);
  - rear: no spacing is required.

### on the rear wall

- S2** distance of the unit from the walls:
- side: keep a minimum space of 20 mm;
  - rear: keep a space necessary to position a siphon (not supplied).

### on the floor under the unit/on the floor outside the unit

- S3** distance of the unit from the walls:
- side: keep a minimum space of 20 mm;
  - rear: no spacing is required.
- Take into account the height of the unit from the ground (100 mm) when choosing or positioning the siphon.

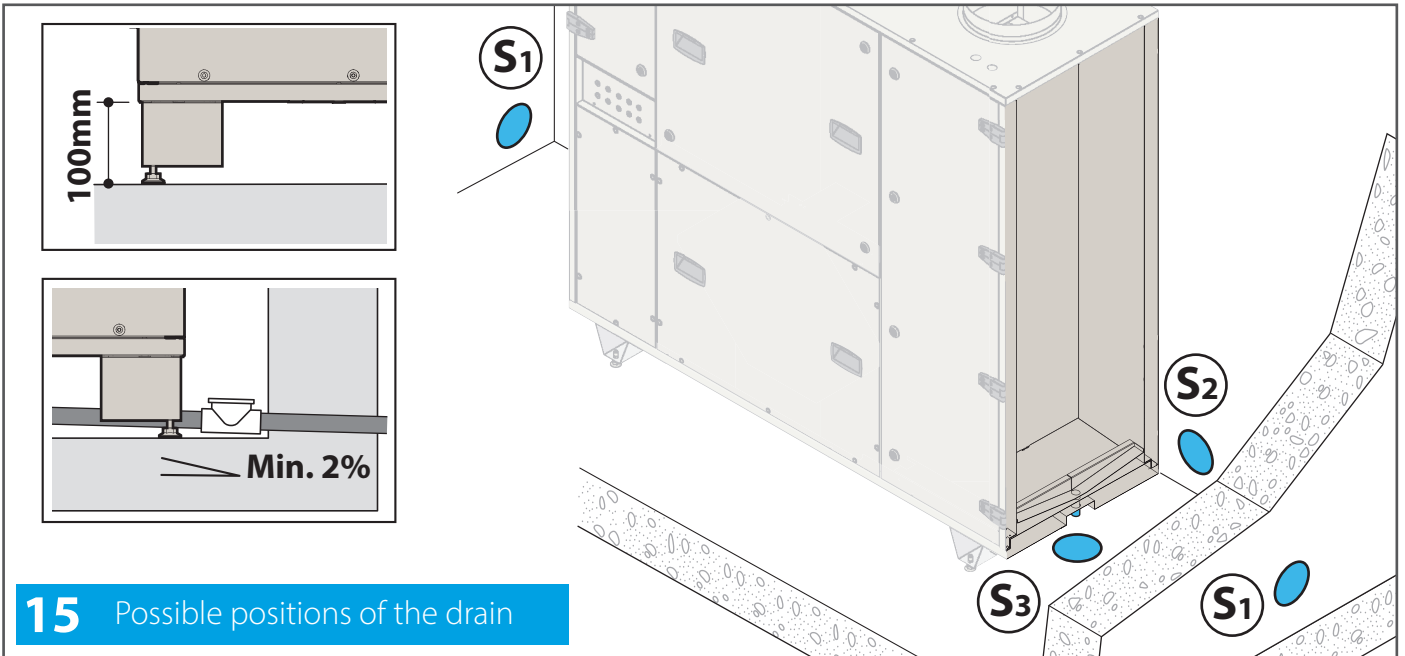

**15** Possible positions of the drain

**16** The drain pipe must have a larger diameter than the unit drain (3/4" F) and a minimum inclination of 2% in order to guarantee its operation. In case of wall drain, it is advisable to use a 90MF 3/4" fitting (not supplied) to avoid narrowing in the drain pipe.

**16** Drain pipe

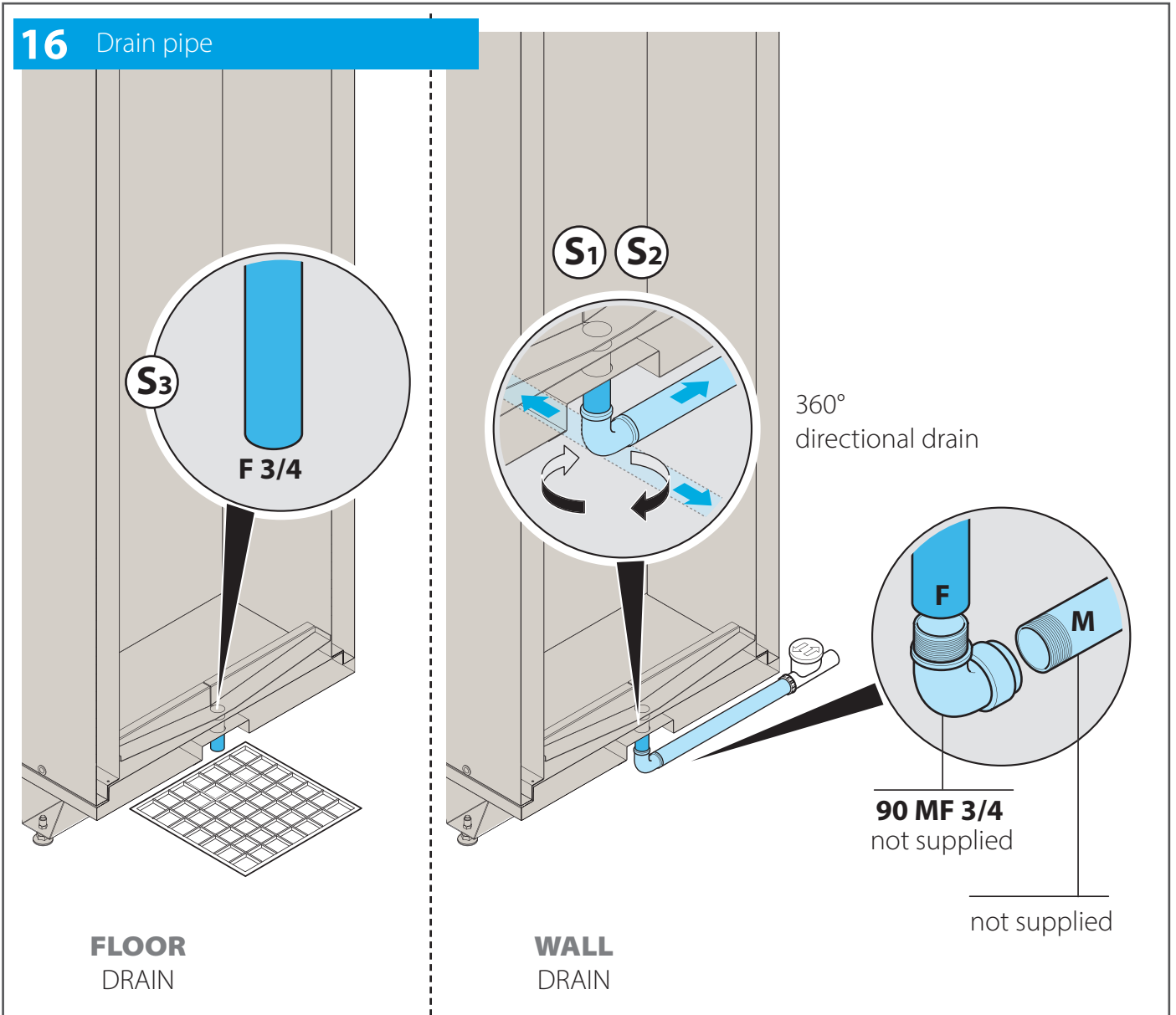

## PHASE 9: AERAULIC CONNECTIONS (SUGGESTED PHASE)

**17** Air ducts are not supplied with the unit. The installer must buy and install them separately.

For a correct installation the following is suggested:

- Clean the joint surfaces between the duct and the unit/coil.
- Apply a gasket to the flange in order to prevent air infiltration.
- Carefully tighten the connecting screws.
- proceed with sealing the gasket in order to optimise its seal.

In order to ensure the seal of the connection and the integrity of the unit's structure, it is essential to make sure that the ducts do not weigh on it, being supported by their own brackets.



Upon request to the manufacturer, an attenuator is available, specific for Compact T to be mounted on the return or supply air duct.

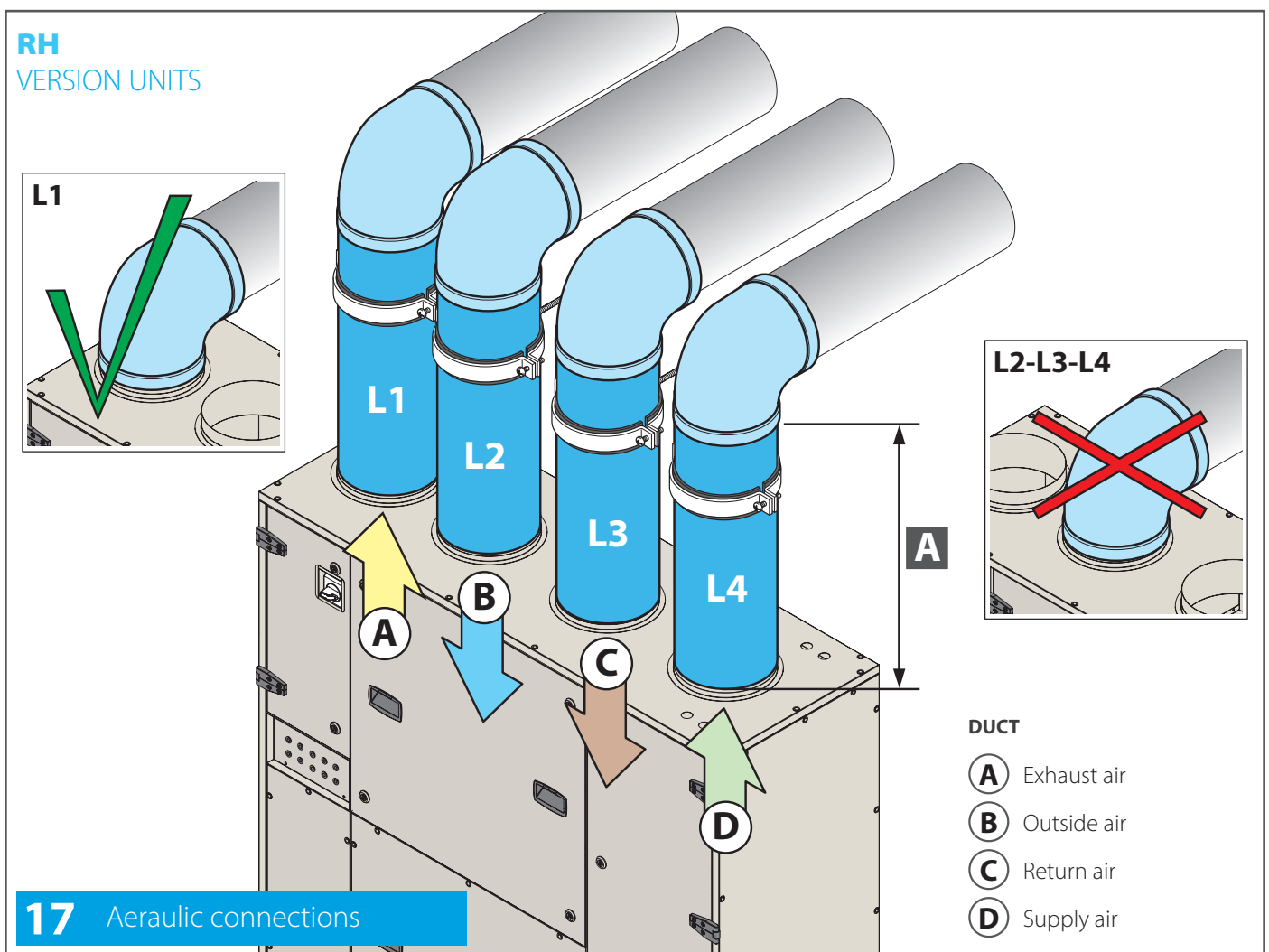

		STRAIGHT DUCTS <b>A</b> MINIMUM LENGTH RECOMMENDED					
		SIZE ▶	3	4	5	6	7
Straight duct	<b>L1</b>	mm	if necessary, a bend can be fitted directly on the collar				
	<b>L2</b>	mm	250	315	355	400	500
	<b>L3</b>	mm	250	315	355	400	500
	<b>L4</b>	mm	500	630	710	800	1000

## PHASE 10: TESTING

To commission the unit it is necessary to (tick "√" the operations completed):

	check for accurate fluid inlet and outlet pipe connections to the coils (if applicable)
	Check that there is a suitable siphon for all the water being drained.
	check unit integrity;
	check that the installation of the sections is correct (only for size 5-6-7)
	check that the electrical connections have been made correctly
	Remove extraneous materials (e.g., assembly sheets, tools, clips, etc.) and dirt (footprints, dust, etc.) from inside the sections.

## PERSONAL PROTECTIVE EQUIPMENT

Personal protective equipment should be used when operating the unit, suitable for use in accordance with company criteria and rules.

During unit maintenance, other preventive measures are suggested in addition to the above: safety shoes, gloves, suitable clothing, always compatible with the use and according to company guidelines.

## TRAINING

It is the responsibility of the unit buyer/user to provide adequate instruction and training to unit operators.

## OPTIONAL

In agreed cases, additional training may be provided through the one-on-one instruction of operators by the Manufacturer's technical staff.

# 7 Maintenance

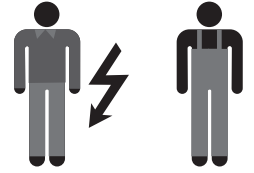

## Safety precautions for maintenance



Ordinary and extraordinary maintenance must be carried out **solely by the operator assigned to perform maintenance** (mechanical and electrical maintenance staff) according to the regulations in force in the country of use and complying with the laws regarding systems and work safety. Remember that, by operator assigned to perform maintenance is meant the person who can work on the unit to perform ordinary and extraordinary maintenance, repairs and fine tuning. This person must be an expert operator, properly instructed and trained, given the risks involved in such operations.



Before performing any ordinary and extraordinary maintenance, the unit **must always be stopped (by disconnecting from the mains)** and **the EMERGENCY button engaged**. The switch must have a key that must be removed and held by the operator who will perform the operations until the end of the maintenance itself.



**It is absolutely prohibited to remove any protections** from moving parts and unit protection devices with the unit connected to the mains or operational. Adjustments made with safety devices disengaged must be performed **by a single person**, expert and authorised, and during this activity it is necessary to prevent access to the area of the unit by other people. Upon completing the adjustments with safety devices disengaged, the protections must be re-engaged as soon as possible.



During maintenance the operational space surrounding the unit must be free of obstacles, clean and well lit. It is prohibited for unqualified people to pass through or remain in this space.



Use personal protective clothing (safety shoes, safety glasses, gloves, etc.) compliant with regulations.



Before carrying out repairs or other work on the unit, **always declare out loud** your intentions to other operators who are located in the unit area and make sure that they have heard and understood the warning.



# Ordinary maintenance

Proper maintenance of the systems maintains efficiency (reducing costs) and consistent performance over time, and increase the usable life of the equipment.

ACTIVITY	FREQUENCY				
	A	B	C	D	E
General cleaning of the unit.		√			
Check and eventual disassembly and washing of filters.				√	
Replacing the filters (when they have deteriorated).	<b>in case of alarm</b>				
Clean the finned surfaces of the coils (if provided) with a compressed air jet and soft brush.	√				
Clean the exchange surfaces of heat recuperators with a compressed air jet and soft brush.	√				
Empty and clean the condensate drain pans.		√			
Visual inspection for corrosion, limescale, release of fibrous substances, any damage, abnormal vibrations, etc. (if possible, it is advisable to extract the components for a more thorough inspection).			√		
Check condensate drain and cleaning of siphons.		√			
In the case of water coils check for the presence of Legionella.		√			
Cleaning of the heat exchanger		√			
Check tightness of screws and bolts in the fan section.	√				
Check the impeller and various devices, with removal of any buildup.	√				
Check the integrity of piping connected to pressure gauges and pressure switches.		√			
Check the ground connection.		√			
Power connection terminal tightness	√				

**A: every year**

**B: every six months**

**C: every 3 months**

**D: every month**

## GENERAL INFORMATION ON CLEANING PROCEDURES



Read the safety instructions at the beginning of this manual and page. 37



**Warning: turn off the unit before ordinary and extraordinary maintenance and wait at least 120 seconds before carrying out any maintenance**



You should consult with your supplier of chemical products to choose the most suitable for cleaning the unit components.



For the cleaning method refer to the instructions of the detergent manufacturer and carefully read the safety data sheet (SDS).

As general guidelines, refer to the following rules:

- Always use personal protection (safety shoes, safety glasses, gloves, etc.).
- Use mild products (pH between 8 and 9) for washing and disinfecting, in normal concentrations. Detergents must not be toxic, corrosive, flammable or abrasive.
- Use a soft cloth or bristle brushes that do not damage the stainless steel surfaces.
- If you use water jets, the pressure should be less than 1.5 bar and the temperature must not exceed 60 °C.
- To clean components like motors, damper motors, bearings, Pitot tubes, filters and electronic sensors (if applicable), do not spray water directly on them.
- After cleaning make sure that you have not damaged the electrical parts and the gaskets.
- Cleaning operations should not involve the lubricated parts, like impeller shafts, because this could affect their good operation and create problems with durability.
- For the cleaning of finned components or dampers use an industrial vacuum cleaner and/or a compressor. Attention, the compressed air flow must run opposite to the direction of airflow through the unit.
- To clean plastic components such as tapping points, grommets, cable glands, connecting pipes and clicks, use a cloth soaked in alcohol. We recommend carrying out the operation during the general cleaning of the unit and when replacing the filters. If cleaning with the alcohol-soaked cloth is insufficient, replace the plastic components

## CLEANING THE EXCHANGER

Remove the dust and fibres with a soft bristle brush or a vacuum cleaner.



Be careful when cleaning with compressed air because the exchanger package can be damaged. CLEANING with pressure jets is allowed if the maximum water pressure is 1.5 bar and a flat nozzle is used (40° - WEG 40/04 type).

Oils, solvents, etc. can be removed with water or hot grease solvents, by washing or immersion. Periodically clean the condensate drain tray and fill the drain siphon with water.

## VENTS

Periodically check that there are no new sources of contamination near the air intake. Each component must be checked periodically for the presence of contamination, damage and corrosion. The gasket can be protected with glycerine-based lubricants or replaced with a new one, if worn.

## FAN ASSEMBLY



The unit must be disconnected from the power supply when cleaning the fans.

Fans can be cleaned with compressed air or by brushing them with soap and water or with a neutral detergent.

Finish the cleaning by rotating the fan by hand to verify the absence of abnormal noises.

## CLEANING FILTERS



The unit must **NOT** be running when the filters are removed to avoid drawing in outside air that might be contaminated.

Filters need to be cleaned often and carefully. Usually, the compact filters (G4) can be cleaned **two or three times** by vacuuming them with a vacuum cleaner, or by blowing them with compressed air before replacing them. For replacement, refer to the control system signalling.

## CORRECT FILTER AND PRE-FILTER INSTALLATION (IN THE EVENT OF REPLACEMENT)

Remove the old filters (see previous chapter), extract the new filters from the packaging (in which they are supplied to avoid deterioration during transport and stay on site), insert them in the special containment section, paying attention to their correct positioning.



Remove the filters from their packaging only when ready to install them to avoid getting them dirty and contaminating them.



Make sure that the inside of the filter is not contaminated by external agents. This operation should be carried out about one hour after the first start-up of the unit, the period during which the ducts are cleaned of dust and various debris. Proceeding in this way preserves the filtering sections that cannot be regenerated.



# Extraordinary maintenance



**Turn off the unit before routine maintenance and wait at least 120 seconds before performing maintenance.**

One can not predict extraordinary maintenance as it is normally due to effects of wear or fatigue caused by the incorrect operation of the unit.

## REPLACEMENT OF PARTS



The replacement of parts should be performed by expert personnel::

- Qualified maintenance mechanic
- Qualified maintenance electrician
- Manufacturer technician

The unit is designed to be able to perform all the servicing necessary to maintain good efficiency of the components. However, it sometimes happens that a component fails due to malfunction or wear, so for replacement refer to the executive drawing.

These are the components that may need replacement:

- **18** filters
- **19** exchanger
- fans
- by-pass damper

For some of these operations of a general nature we will not enter into detail as these are operations that fall within the abilities and professional expertise of the staff assigned to perform them.

## CONSUMABLE COMPONENTS - SPARE PARTS

During the operation of the unit there are particular mechanical and electrical components that are most subject to wear. These parts must be monitored in order to carry out their replacement or repair before they cause problems to the correct operation of the unit with consequent downtime.

only for sizes 5 - 6 - 7

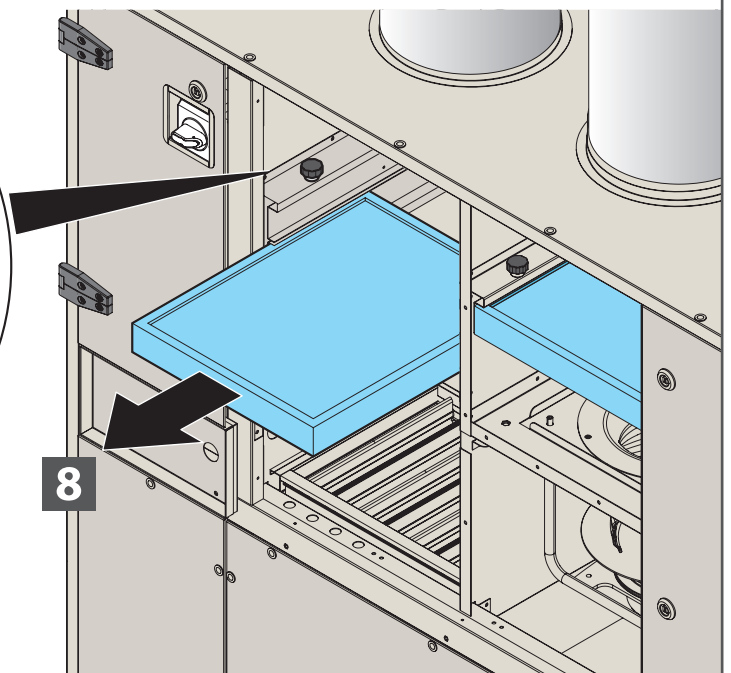
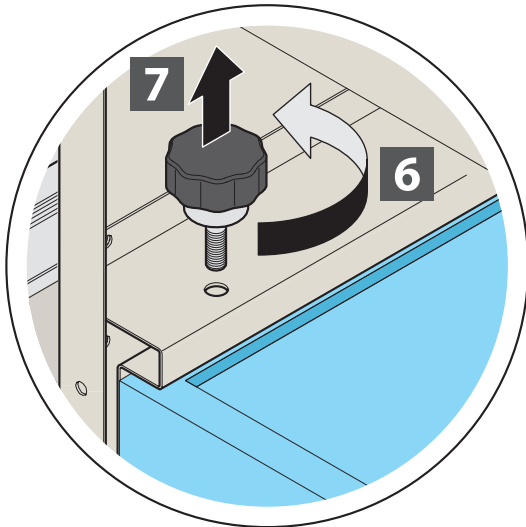
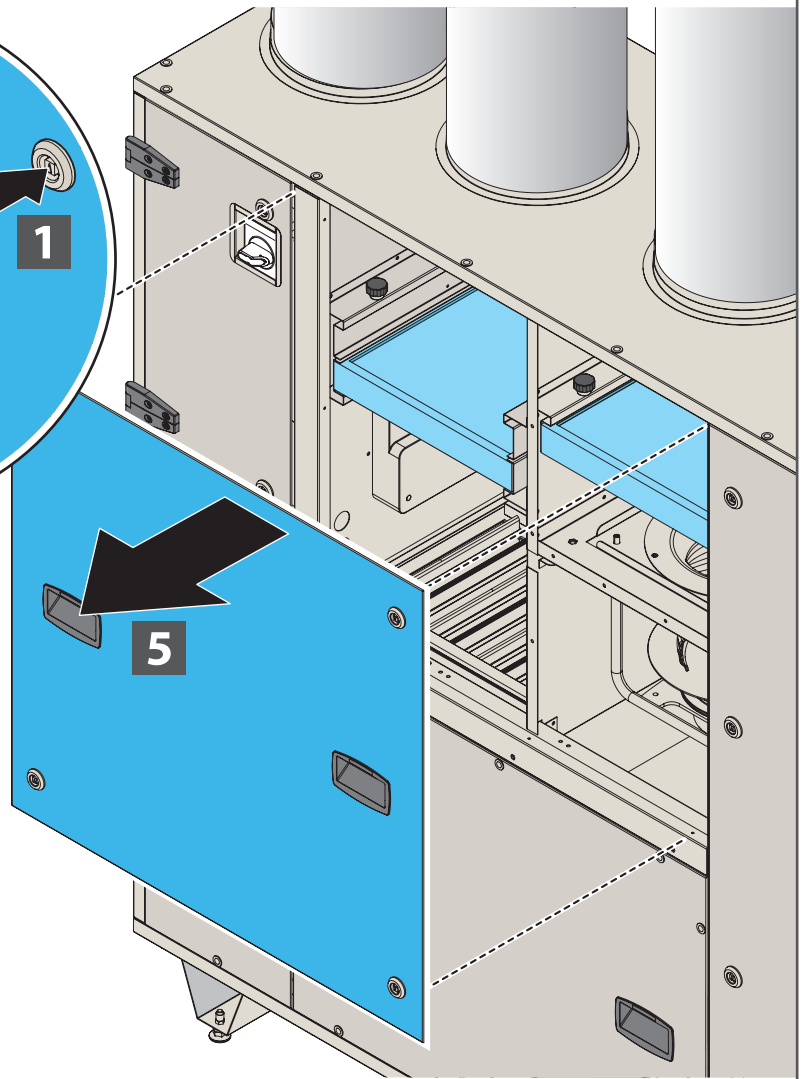
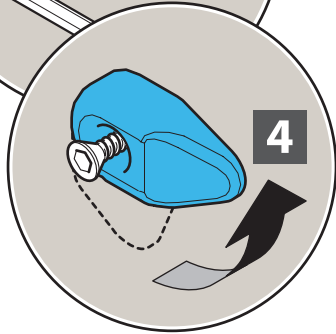
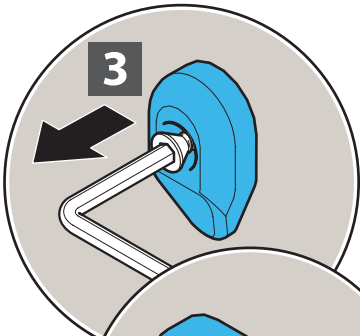
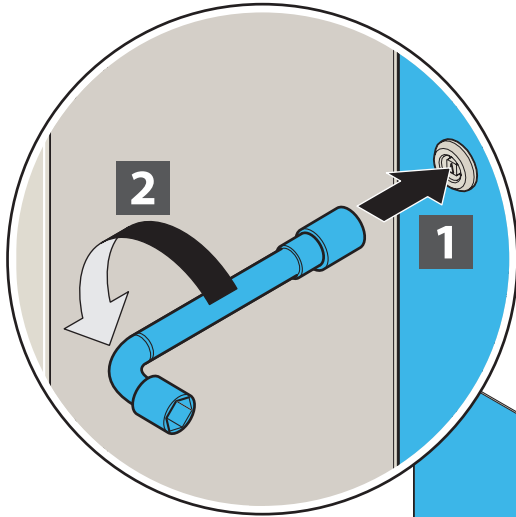

## 18 Filter disassembly

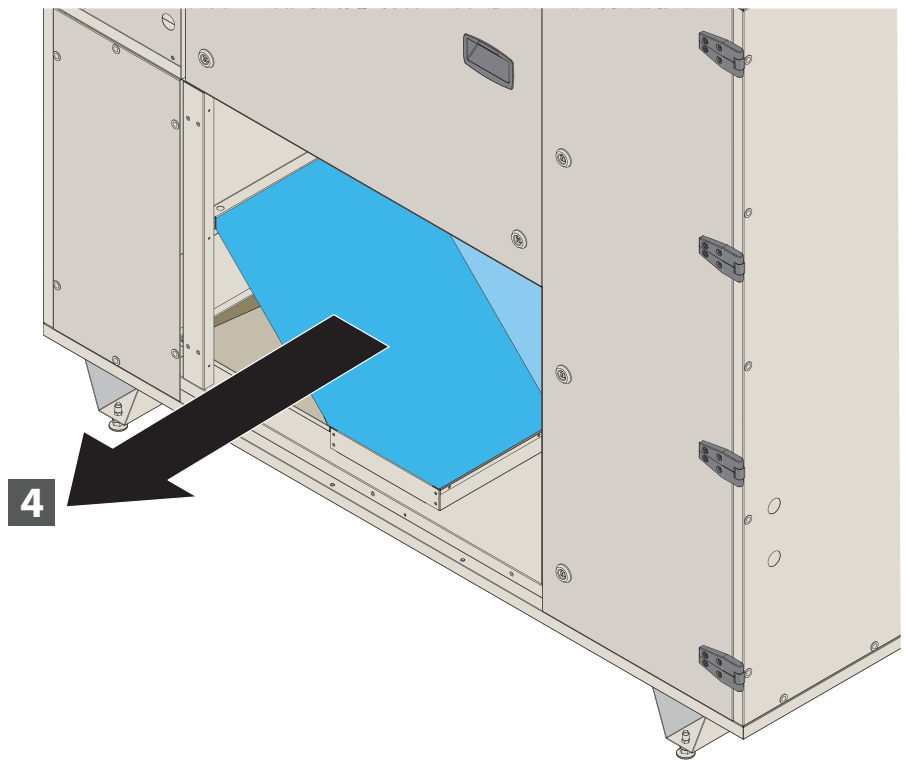
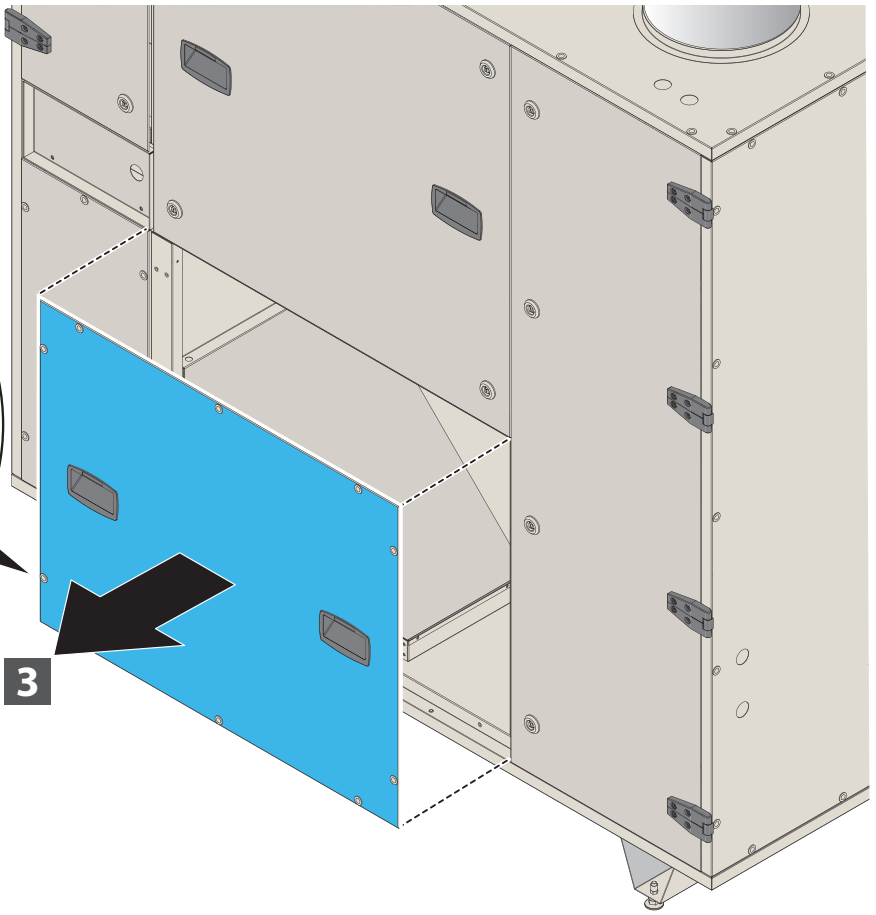
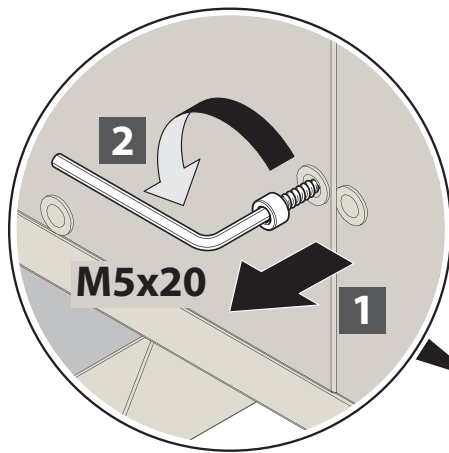

## 19 Exchanger removal

# Disposal of used materials - waste



The unit is made with metal, plastic and electronic components.

All these components must be disposed of in compliance with local disposal laws and, where applicable, with those transposing Directive 2012/19/EU (WEEE).

## Diagnostics

### GENERAL DIAGNOSTICS

The unit's electrical system includes quality electromechanical components and is therefore extremely durable and reliable over time.

Should there be any malfunctions due to malfunctions of electrical components it will be necessary to act as follows:

- Check the fuses of the power supply for the control circuits and if necessary replace them with fuses having the same specifications.
- Check if the thermal protection switch for the motor has been triggered or if its fuses have blown.

If this has occurred, it may be caused by:

- Motor overload due to mechanical problems. They need to be solved.
- Incorrect supply voltage. Verify the protection trip threshold.
- Malfunction and/or short circuits in the motor. Identify and replace the failed component.

### ELECTRICAL MAINTENANCE

Do not modify the unit for any reason and do not add other devices.

The manufacturer is not liable for resulting malfunctions and problems.

Further clarification is available by contacting the manufacturer's Customer Service.

# Troubleshooting table

MALFUNCTION TYPE	COMPONENT	POSSIBLE CAUSE/SOLUTION
NOISE LEVEL	Fan impeller	Impeller deformed, unbalanced or loose
		Nozzle damaged
		Foreign bodies in the fan
	Transmission	Motor or fan not attached well
	Bearings	Bearing worn or deteriorated
	Motor	Incorrect supply voltage
		Worn bearings
		Contact between the rotor and stator
Ducts	Excessive speed in the ducts	
	Anti-vibration joint too taut	
INSUFFICIENT AIR FLOW	Ducts	Load losses superior to the demand
		Dampers closed
		Obstructions in the ducts
	Filters	too dirty
Heat exchange coils	too dirty	
EXCESSIVE AIR FLOW	Ducts	Load losses inferior to the demand
		Ducts too large
		Terminals not installed
	Unit	Filters not inserted
		Access doors open
		Access doors open
INSUFFICIENT THERMAL EFFICIENCY	Coil	Incorrect connection of inlet/outlet piping
		Coil dirty
		Air bubbles in the pipes
		Excessive air flow
	Electric pump	Insufficient water flow
		insufficient pressure
		Wrong direction of rotation
	Fluid	Temperature different from the project
Incorrect regulation bodies		
WATER LEAK	Fan section	Leak from the coil due to corrosion
		Dragging of drops due to high air velocity
		Clogged "overflow" drain

# Optional accessory assembly



- D-EIMOC2009-20\_COMPACT TOP ADDITIONAL FILTER
- D-EIMOC2009-21\_COMPACT TOP INTERNAL WATER/DX COILS
- D-EIMOC2009-22\_COMPACT TOP ELECTRIC PRE/POST HEATING
- D-EIMOC2009-23\_COMPACT TOP INTERNAL POST HEATING WATER COIL
- D-EIMOC2009-24\_COMPACT TOP SILENCERS
- D-EIMOC2009-25\_COMPACT TOP MIXING DAMPER
- D-EIMOC2009-26\_COMPACT TOP EXTERNAL DAMPER
- D-EIMOC2009-27\_COMPACT TOP DIGITAL NODE
- D-EIMOC2009-28\_COMPACT TOP PRE HEATING WATER COIL
- D-EIMOC2009-29\_COMPACT TOP FROST SWITCH

# Repair log

DATE	SERVICE TYPE	TIME REQUIRED	SIGNATURE

**DAIKIN APPLIED EUROPE S.p.A.** Via Piani S. Maria, 72 - 00072 Ariccia (Rome) Italy - [www.daikinapplied.eu](http://www.daikinapplied.eu)



This publication is drawn up only as a technical support and does not constitute a binding commitment for Daikin Applied Europe S.p.A. Daikin Applied Europe S.p.A. has drawn up the content to the best of its ability. No explicit or implicit guarantee is given as to the completeness, precision or reliability of its content. All the data and specifications contained herein are subject to change without notice. The data stated at the time of the order prevail. Daikin Applied Europe S.p.A. accepts no liability whatsoever for any direct or indirect damage, in the broadest sense of the word, deriving from or associated with the use and/or interpretation of this publication.  
All content is protected by the copyright of Daikin Applied Europe S.p.A.

D-EIMAH01806-22\_01EN