

DAIKIN



| | |
|------------|-------|
| REV | 00 |
| Date | 01/23 |
| Supersedes | |

**Installation & Operating Manual
D-EIOCP00301-23_00EN**

Smart Grid Box

CONTENTS

| | | |
|----------|--|----------|
| 1 | INTRODUCTION | 3 |
| 1.1 | Description of the SG Box | 3 |
| 1.2 | System layout and Requirements | 4 |
| 2 | RECEIVING THE SG BOX | 5 |
| 3 | INSTALLATION | 5 |
| 3.1 | To mount the rear casing to the wall | 5 |
| 4 | ELECTRICAL INSTALLATION | 6 |
| 4.1 | Overview of electrical connections | 6 |
| 4.2 | To connect the box to the heat pump | 7 |
| 5 | UNIT CONTROL CONFIGURATION | 7 |
| 5.1 | Master/Slave case | 7 |
| 5.2 | BMS Case | 7 |
| 6 | OPERATION | 8 |
| 6.1 | Operation modes | 9 |
| 6.1.1 | "Normal operation/Free running" mode..... | 9 |
| 6.1.2 | "Recommended ON" mode | 9 |
| 6.1.3 | "Forced OFF" mode | 9 |
| 6.1.4 | "Forced ON" mode | 9 |
| 7 | DISPOSAL | 9 |

1 INTRODUCTION

This manual is an important supporting document for qualified personnel, as authorized installer.



READ THIS MANUAL CAREFULLY BEFORE INSTALLING THE BOX.



UNIT INSTALLATION AND START UP IS ABOSOLUTELY FORBIDDEN IF ALL INSTRUCTIONS CONTAINED IN THIS MANUAL ARE NOT CLEAR.
IN CASE OF DOUBT CONTACT THE MANUFACTURER REPRESENTATIVE FOR ADVICE AND INFORMATION.

Latest revisions of the supplied documentation may be available on the Daikin website or via your dealer. The original documentation is written in English. All other languages are translations.

1.1 Description of the SG Box

The Smart Grid Box is an accessory that allows the integration of the heat pump control for a Smart Grid application. Before the installation, make sure that the heat pump system is compatible for use with the Smart Grid Application.

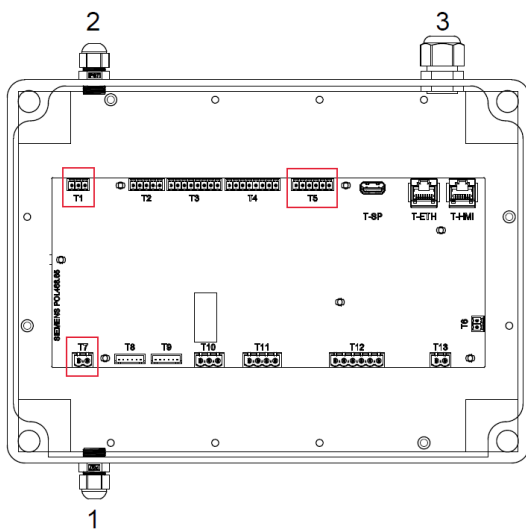

- 1: Power supply entry;
- 2: Modbus cable entry;
- 3: Digital Inputs entry;

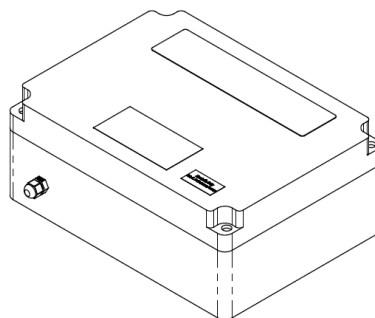

1.2 System layout and Requirements

To integrate the Smart Grid Box into a Daikin Applied Heat Pump, the system layout should be designed to be compatible with the new control functionalities.

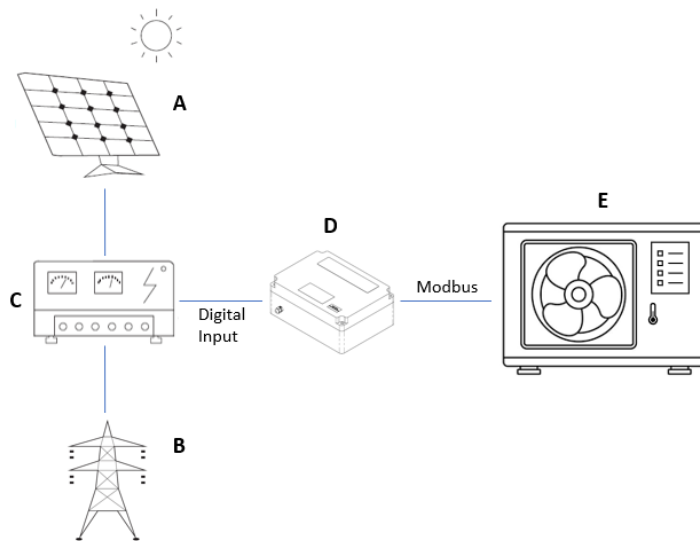

- A: Solar panels
- B: Grid
- C: Interface-compatible system components (Solar inverter / energy management system)
- D: Smart Grid Box
- E: Heat Pump

Interface-compatible system components are those devices that can transmit digital signals to a heat pump in accordance with the smart grid specifications, in order to control it with regard to energy consumption or another target variable. The interface can also be used, for example, to achieve the highest possible self-consumption in combination with a photovoltaic system.



To ensure the heat pump follows the grid inputs install a proper interface-compatible system.

For proper system set-up, the following system requirements must be ensured:

| Item | Requirement |
|-----------------------------|---|
| Heat Pump software | It is recommended to ALWAYS keep the unit software up-to-date. |
| Unit control settings | To activate the SG Ready functions the unit shall not be disabled using the selector Q0. The status "SG Enable" should be set at "ON" |
| Domestic hot water settings | The SG Ready functions are compatible with the DHW function. To allow energy buffering in the domestic hot water tank no additional settings should be fixed. |



To perform the software update, contact authorized Daikin service personnel only.

2 RECEIVING THE SG BOX

The Smart Grid Box shall be inspected for any possible damage immediately upon reaching the final place of installation. Should the product be damaged, do not remove the damaged material and immediately report the damage to the transportation company and to the manufacturer representative.

Responsibility for any damage after acceptance of the product cannot be attributed to the manufacturer.

3 INSTALLATION

The installation of the Smart Grid Box consists of the following stages:

1. Open the box
2. Mount the rear casing to the wall
3. Connect electrical wiring
4. Close the front casing to the rear casing



RISK OF ELECTROSTATIC DISCHARGE

Before mounting the PCB, touch an earthed part to eliminate static and protect the PCB from damage. ONLY handle the PCB by its sides.



READ THE MAXIMUM CABLE LENGTH REQUIREMENTS SET OUT IN THIS MANUAL.

3.1 To mount the rear casing to the wall

1. Hold the rear casing against the wall and mark the position of the holes.
2. Drill the holes.
3. Mount the rear casing to the wall with the screws and plugs from the box (additional kit provided).



Provide enough space to connect the power supply cable without exceeding the minimum bend radius.



The Smart Grid Box is designed to be wall-mounted. Make sure the installation surface is a flat and vertical non-combustible wall.

The Smart Grid Box is designed to operate in ambient temperatures ranging from -40...70 °C.

4 ELECTRICAL INSTALLATION



Do NOT turn on the power supply before you have connected all the wiring and closed the SG Box.



When connecting the wiring to the Smart Grid Box make sure each wire is securely fastened to the appropriate terminal. Use a screwdriver to open the wire clamps. Make sure the bare copper wire is fully inserted into the terminal (bare copper wire cannot be visible).

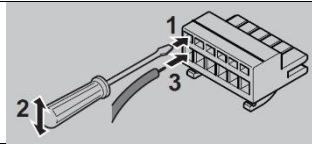

4.1 Overview of electrical connections



To prevent damage and/or injury, do NOT make any connection different than the following wiring diagram.

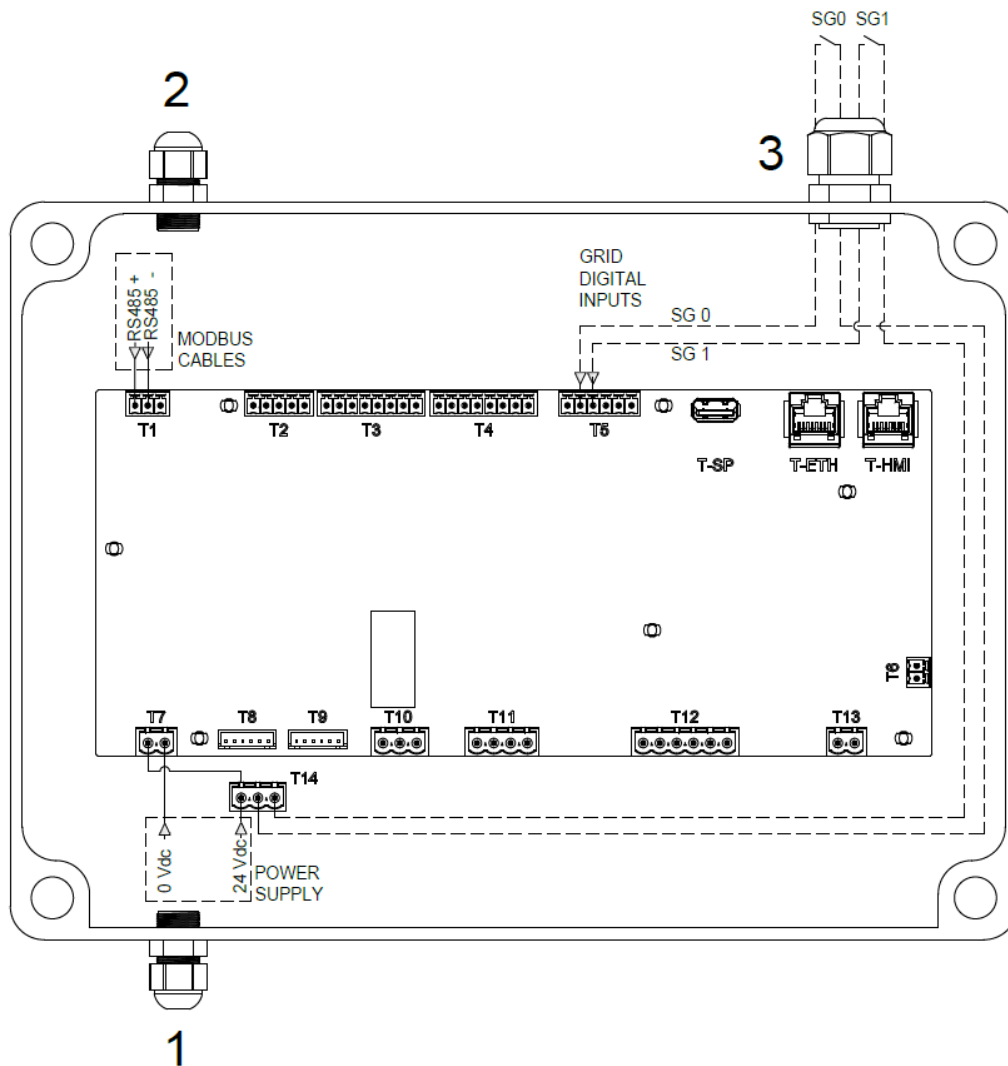

| | CABLE REQUIREMENTS | | Maximum cable length |
|---|----------------------------|---------------------|--|
| 1 | Power Supply | 1,5 mm ² | 70m (maximum voltage drop 24 V ± 10%) |
| 2 | Modbus communication RS485 | 0,5 mm ² | <ul style="list-style-type: none"> • Bus cable length between 2 units Max. 700 m • Total bus cable length Max. 1.000 m |
| 3 | Digital Input | 1mm ² | 80m |

These wires MUST be sheathed. Recommended strip length: 6 mm

4.2 To connect the box to the heat pump

For a proper wiring connection of the Smart Grid Box read this manual and the wiring diagram of the unit. In some case the power supply could be provided by the unit: from the 24Vdc terminal block the connection points 703(+) 704(-) could be used.

- For the EWYT_CZ (package and split) the terminal block is XD.
- For the EWWQ-KC the terminal block is XRC

The unit terminals must be wired on the adapter terminal T14.

In other cases, the power supply 24Vdc for the Smart Grid Box is not provided directly by the unit (AC voltage only). Contact the Daikin service personnel to find a technical solution (rectifier) or provide externally the power supply to the box, making sure to follow the maximum voltage drop requirement.

5 UNIT CONTROL CONFIGURATION

To enable the Smart Grid functionality and allow the proper interface between the unit and the box:

- Configure unit
- Link SG Box properly to the Modbus network

It is possible to activate the configuration using available interfaces detailed in the Operating Manual of the unit. Once the BEG state has been switched on and the unit has been reactivated the unit will follow the grid requirements set by the Smart Grid box.

5.1 Master/Slave case

In case of master/slave, it will be possible to use up to 4 units linked to the same SG Box. In order to perform SG functionalities, system configuration shall be done for each unit, both master and slaves.

Only one master unit must be connected to the Smart Grid Box via Modbus cables, the slave units will follow the “smart grid state” of the master unit.

- It is possible to exclude one unit from Master staging using the setpoint “standalone” of the slave units.
 - o If the master is set as standalone all the slaves are set as standalone

All the references for the configuration steps are detailed in the operating manual of the unit.



If there is a loss of communication with the SG Box, the heat pump starts running in normal operation without considering the last Smart Grid State received.

5.2 BMS Case

In case a BMS is installed to manage the heating system, the box must be connected directly to the BMS.

- More than 4 units could be handled in this configuration

The Modbus parameters needed for the Smart Grid states are defined in the table below:

| BAUD | PARITY | 2STOPBIT |
|-------|--------|------------|
| 38400 | EVEN | 1 STOP BIT |

The data reading is done by the Holding Register.

| Holding register | Name | R/W |
|------------------|-----------|-----|
| 14 | BEG State | R |

6 OPERATION



To use the Smart Grid application, the heat pump should not be switched off manually by an external switch (See operating manual of the heat pump).

Alternatively, to disable the possibility of using the Smart Grid Box, it is possible to set the HMI parameter "SG Enable" switched 0 to "OFF".



For a good understanding of the Smart Grid application, and to be able to properly configure the system, it is recommended to first read up the following instructions.

The Smart Grid Box allows the connection of the Daikin Heat Pumps system to a solar inverter/energy management system and enables it to run in various Smart Grid operation modes. In this way, all system components work together to limit the injection of (self-generated) power into the grid, instead of converting this power into thermal energy by making use of the heat pump's thermal storage capacity. This is called "energy buffering".

The system can buffer energy in the following ways:

- Heat up the domestic hot water tank.
- Heat up the water living temperature.

The Smart Grid application is controlled by the solar inverter/energy management system, that monitors the grid, and sends commands to the Smart Grid Box. The box is connected to the solar inverter/energy management system (digital outputs) via connectors (digital inputs)

| Digital Outputs (Solar inverter/energy management system/grid interface) | Terminal Block T5 Digital Inputs |
|---|-------------------------------------|
| Digital output 1 | SG0 |
| Digital output 2 | SG1 |

| Smart Grid operation mode | SG 0 (DI1) | SG 1 (DI2) |
|--|---------------|---------------|
| Normal operation/Free running NO Smart Grid application (ON1) | Open | Open |
| Recommended ON Energy buffering in the domestic hot water tank and/or the room with primary water setpoint activated (ON2) | Closed | Open |
| Forced OFF Deactivation of the unit for a maximum of two hours. | Open | Closed |
| Forced ON Energy buffering in the domestic hot water tank and/or the room with secondary water setpoint activated (ON2) | Closed | Closed |



For the system to run in all 4 possible Smart Grid operation modes, the solar inverter/energy management system needs to have 2 digital outputs available. If only 1 output is available, then you can only connect to SG0, and the system can only run in the "Normal operation/Free running" and "Recommended ON" operation modes. For the system to run in "Forced OFF" and "Forced ON", a connection to SG1 is required (for those operation modes, SG1 needs to get "closed").



In case the system layout includes a controllable wall socket, and the solar inverter/energy management system activates this socket, SG0 gets "closed" and the system runs in the "Recommended ON" operation mode. If the solar inverter/energy management system deactivates the socket, SG0 (and SG1) get "opened" and the system runs in the "Normal operation/Free running" operation mode.

6.1 Operation modes

The solar inverter/energy management system controls the state of the Smart Grid Box digital inputs. Depending on the state of the inputs (open or closed), the Daikin heat pumps can run in the following Smart Grid operation modes.

6.1.1 "Normal operation/Free running" mode

In the "Normal operation"/"Free running" operation mode, the heat pump operates as normal, according to its owner's settings and schedules. No Smart Grid functionalities are enabled.

6.1.2 "Recommended ON" mode

In the "Recommended ON" operation mode, the heat pump system makes use of solar/grid power (when it is available, as measured by the solar inverter/energy management system) to produce domestic hot water and/or heat up the space. The amount of solar/grid power that is used for buffering depends on the domestic hot water tank and/or the water temperature according to the customer system set up.

6.1.3 "Forced OFF" mode

In the "Forced OFF" operation mode, the solar inverter/energy management system triggers the system to deactivate the operation of the outdoor unit compressor and the electrical heaters. This is especially useful in case of energy management systems that react to high energy tariffs, or in case of grid overload (signalled by the energy distributor to the energy management system). Once active, "Forced OFF" mode will cause the system to stop space heating, as well as domestic hot water production.



Once running in one of the Smart Grid operation modes, the system will keep running in that mode until the input state of the SG Box is changed. Beware that if the system runs in "Forced OFF" mode for a long time (maximum two hours), comfort issues can occur.

6.1.4 "Forced ON" mode

In the "Forced ON" operation mode, the heat pump system makes use of solar/grid power (when it is available, as measured by the solar inverter/energy management system) to produce domestic hot water and/or heat up or cool down the space.

The amount of solar/grid power that is used for buffering depends on the domestic hot water tank and/or the water temperature.

The "Forced ON" operation mode is particularly useful in case of energy management systems that react to low energy tariffs, in case of grid overload (signalled by the energy distributor to the energy management system), or when multiple houses are connected to the grid that are controlled simultaneously, this to stabilise the grid.



Once running in one of the Smart Grid operation modes, the system will keep running in that mode until the input state of the SG Box is changed.

7 DISPOSAL

The unit is made of metal, plastic and electronic parts. All of these components must be disposed of in accordance with local disposal laws and if in scope with the national laws implementing the Directive 2012/19/EU (RAEE).



The present publication is drawn up by of information only and does not constitute an offer binding upon Daikin Applied Europe S.p.A.. Daikin Applied Europe S.p.A. has compiled the content of this publication to the best of its knowledge. No express or implied warranty is given for the completeness, accuracy, reliability or fitness for particular purpose of its content, and the products and services presented therein. Specification are subject to change without prior notice. Refer to the data communicated at the time of the order. Daikin Applied Europe S.p.A. explicitly rejects any liability for any direct or indirect damage, in the broadest sense, arising from or related to the use and/or interpretation of this publication. All content is copyrighted by Daikin Applied Europe S.p.A..

DAIKIN APPLIED EUROPE S.p.A.

Via Piani di Santa Maria, 72 - 00072 Ariccia (Roma) - Italia

Tel: (+39) 06 93 73 11 - Fax: (+39) 06 93 74 014

<http://www.daikinapplied.eu>