

EWAQ-G

Air cooled multiscroll
chillers

Product manual

SS (Standard Efficiency - Standard Noise) - Cooling Capacity from 75 to 154 kW
SR (Standard Efficiency - Reduced Noise) - Cooling Capacity from 69 to 143 kW
XS (High Efficiency - Standard Noise) - Cooling Capacity from 80 to 149 kW
XR (High Efficiency - Reduced Noise) - Cooling Capacity from 76 to 141 kW

Performance according to EN14511
Eurovent certified
Refrigerant: R410A

CODE	CSSweb - Rev. 11.0
Date	July 2016
Supersedes	R3.7.3

Table of content

EWAQ-G

Features and benefits		2	Operating limits	
General characteristics		3	Operating envelope	23
Options		6	Cooling performance	
Nomenclature		8	Silver Series	
Technical specifications performance data			EWAQ G SS	27
Silver Series			EWAQ G SR	29
EWAQ G SS	9		Gold series	
EWAQ G SR	11		EWAQ G XS	31
Gold series			EWAQ G XR	33
EWAQ G XS	13		Pump Curves	
EWAQ G XR	14		Silver Series (SS/SR)	35
Electrical specifications			Gold series (XS/XR)	36
Silver Series			Dimensional drawings	39
EWAQ G SS	15		Installation notes	42
EWAQ G SR	16		Technical specification	44
Gold series				
EWAQ G XS	17			
EWAQ G XR	18			
Sound levels @ 1m from unit		19		
Silver Series				
EWAQ G SS	19			
EWAQ G SR	20			
Gold series				
EWAQ G XS	21			
EWAQ G XR	22			

Low operating cost and extended operating life This chiller range is the result of careful design, aimed to optimize the energy efficiency of the chillers, with the objective of bringing down operating costs and improving installation profitability, effectiveness and economical management.

The chillers feature high efficiency scroll compressors, large condenser coil surface area for maximum heat transfer and low discharge pressure, continuous fan speed modulation, and a 'plate to plate' evaporator with low refrigerant pressure drops.

Low operating sound levels Very low sound levels both at full load and part load conditions are achieved by the latest compressor design and by a unique new fan that moves large volume of air at exceptionally low sound levels and by the virtually vibration-free operation.

Outstanding reliability The chillers have one refrigerant circuit. The unit is equipped with hermetic orbiting scroll compressor complete with motor over-temperature and over-current devices and protection against excessive gas discharge temperature, a proactive control logic and are full factory-run-tested to optimized trouble-free operation.

Superior control logic The new controller provides an easy to use control environmental. The control logic is designed to provide maximum efficiency, to continue operation in unusual operating conditions and to provide a history of unit operation. One of the greatest benefits is the easy interface with LonWorks, Bacnet, Ethernet TCP/IP or Modbus communications.

Code requirements – Safety and observant of laws/directives

Units are designed and in accordance with applicable selections of the following:

Construction of pressure vessel	97/23/EC (PED)
Machinery Directive	2006/42/EC
Low Voltage	2006/95/EC
Electromagnetic Compatibility	2004/108/EC
Electrical& Safety codes	EN 60204-1 / EN 60335-2-40
Manufacturing Quality Stds	UNI – EN ISO 9001:2004

Certifications Units are CE marked, complying with European directives in force, concerning manufacturing and safety. On request units can be produced complying with laws in force in non European countries (ASME, GOST, etc.), and with other applications.

Versions This range is available in two different versions:

STANDARD EFFICIENCY

7 sizes to cover a range from 75 up to 154 Kw with an EER up to 2.76 and an ESEER up to 4.23 (data referred to Standard Noise).

HIGH EFFICIENCY

6 sizes to cover a range from 80 up to 149 Kw with an EER up to 3.12 and an ESEER up to 4.36 (data referred to Standard Noise).

The EER (Energy Efficiency Ratio) is the ratio of the Cooling Capacity to the Power Input of the unit. The Power Input includes: the power input for operation of the compressor, the power input of all control and safety devices, the power input for fans.

The ESEER (European Seasonal Energy Efficiency Ratio) is a weighed formula enabling to take into account the variation of EER with the load rate and the variation of air inlet condenser temperature.

$$ESEER = A \times EER_{100\%} + B \times EER_{75\%} + C \times EER_{50\%} + D \times EER_{25\%}$$

	A	B	C	D
K	0.03 (3%)	0.33 (33%)	0.41 (41%)	0.23 (%)
T	35°C	30°C	25°C	20°C

K = Coefficient; T = Air inlet condenser temperature.

Sound configurations Standard and reduced sound configurations available as follows:

STANDARD SOUND

Condenser fan rotating at 1360 rpm, rubber antivibration under compressor.

REDUCED SOUND

Condenser fan rotating at 1108 rpm, rubber antivibration under compressor, compressors acoustic insulation.

Cabinet and structure The cabinet is made of galvanized steel sheet and painted to provide a high resistance to corrosion. Colour Ivory White (Munsell code 5Y7.5/1) (\pm RAL7044).The base frame has an eye - hook to lift the unit with ropes for an easy installation. The weight is uniformly distributed along the profiles of the base and this facilitates the arrangement of the unit.

Compressor The compressors are hermetic orbiting scroll compressor complete with motor over - temperature and over - current devices. An oil heater, which starts automatically, keeps the oil from being diluted by the refrigerant when the compressor stops. The compressors are connected in Tandem on a single refrigerating circuit and are fitted on rubber antivibration mounts and complete with oil charge.

Refrigerant Units have been optimized to operates with R - 410A, refrigerant with zero ODP (Ozone Depletion Potential). R - 410A has been the logical choice for our multiple scroll chiller because today it is one of the most promising refrigerants in terms of efficiency, stability and environmental impact. R - 410A offers a small swept volume, a good heat exchange capacity and leads to reduced component sizes of items such as heat exchangers and tubing.

Evaporator (Plate Heat Exchanger) The unit is equipped with a direct expansion plate to plate type evaporator. This heat exchanger is made of stainless steel brazed plates and is covered with a 20mm closed cell insulation material. The exchanger is equipped with an electric heater for protection against freezing. The evaporator is manufactured in accordance to PED approval.

Condenser The condenser is made entirely of aluminum with flat tubes containing small channels. Full - depth louvered aluminum fins are inserted between the tubes maximizing the heat exchange. The Microchannel technology ensures the highest performance with the minimum surface for the exchanger. The quantity of refrigerant is also reduced compared to Cu/Al condenser. The coil is manufactured with a special aluminum alloy characterized by higher resistance to corrosion compared to standard alloy.

Condenser fans (\varnothing 450 mm) The condenser fans are propeller type with high efficiency design blades to maximize performances. The material of the blades is glass reinforced resin and each fan is protected by a guard. Fan motors are internally protected from overtemperature and are IP54.

Electronic expansion valve The unit is equipped with the most advanced electronic expansion valves to achieve precise control of refrigerant mass flow. As today's system requires improved energy efficiency, tighter temperature control, wider range of operating conditions and incorporate features like remote monitoring and diagnostics, the application of electronic expansion valves becomes mandatory.

Electronic expansion valves possess unique features: short opening and closing time, high resolution, positive shut - off function to eliminate use of additional solenoid valve, continuous modulation of mass flow without stress in the refrigerant circuit and corrosion resistance stainless steel body.

Electronic expansion valves are typically working with lower difference between high and low pressure side, than a thermostatic expansion valve. The electronic expansion valve allows the system to work with low condenser pressure (winter time) without any refrigerant flow problems and with a perfect chilled water leaving temperature control.

Refrigerant circuit Each unit has 1 refrigerant circuit that includes:

- Compressors
- Refrigerant
- Evaporator
- Air Cooled Condenser
- Electronic expansion valve
- Charging valves
- High pressure switch
- High pressure transducers
- Low pressure transducers
- Suction temperature sensor

Electrical control panel Power and control are located in the main panel that is manufactured to ensure protection against all weather conditions. The electrical panel is IP54 and (when opening the doors) internally protected against possible accidental contact with live parts. The main panel is fitted with a main switch interlocked door that shuts off power supply when opening.

Power Section

The power section includes compressors and fans protection devices, compressors and fans starters and control circuit power supply.

Unit controller

Unit controller is installed as standard; it can be used to modify unit set - points and check control parameters. A built - in display shows chiller operating status plus temperatures of water, refrigerant, programmable values, set - points. A sophisticated software with predictive logic, selects the most energy efficient combination of compressors and EEXV to keep stable operating conditions to maximise chiller energy efficiency and reliability.

The unit controller is able to protect critical components based on external signs from its system (such as motor

temperatures, refrigerant gas and oil pressures, pressure switches and evaporator). The input coming from the high pressure switch cuts all digital output from the controller in less than 50ms, this is an additional security for the equipment. Fast program cycle (200ms) for a precise monitoring of the system. Floating point calculations supported for increased accuracy in Pressure / Temperature conversions.

Control section main features

Control Section has the following features:

- Management of the refrigerant circuit capacity
- Full routine operation at condition of:
 - high thermal load
 - high evaporator entering water temperature (start - up)
- Display of evaporator entering/leaving water temperature.
- Display of condensing - evaporating temperature and pressure, suction superheat.
- Leaving water evaporator temperature regulation.
- Compressor and pumps hours counter.
- Display of Status Safety Devices.
- Number of starts and compressor working hours.
- Re - start in case of power failure (automatic / manual).
- Soft Load (optimized management of the compressor load during the start - up).
- OAT (Outside Ambient temperature) Reset.
- Start at high evaporator water temperature.
- Return Reset (Set Point Reset based on return water temperature).
- Set point Reset (optional).
- Application and system upgrade with commercial SD cards.

Safety device / logic for each refrigerant circuit

The following devices / logics are available.

- High pressure (pressure switch).
- High pressure (transducer).
- Low pressure (transducer).
- High motor winding temperature.
- No pressure change at start

System security

The following securities are available.

- Under/over voltage (available as option)
- Freeze protection.

Unit controller

Unit controller built - in terminal has the following features.

- 164x44 dots liquid crystal display with white back lighting. Supports Unicode fonts for multi - lingual.
- Key - pad consisting of 3 keys.
- Push'n'Roll control for an increased usability.
- Memory to protect the data.
- General faults alarm relays.
- Password access to modify the setting.
- Application security to prevent application tampering or hardware usability with third party applications.
- Service report displaying all running hours and general conditions.
- Alarm history memory to allow an easy fault analysis.

Supervising systems (on request)

Unit controller remote communication

Unit controller is able to communicate to BMS (Building Management System) based on the most common protocols as:

- ModbusRTU
- LonWorks, now also based on the international 8040 Standard Chiller Profile and LonMark Technology.
- BacNet BTP certified over IP and MS/TP (class 4).
- Ethernet TCP/IP.

GENERAL CHARACTERISTICS

Additional information related to F - GAS Regulation (EU) No 517/2014 of the European Parliament and of the Council of 16 April 2014 on fluorinated greenhouse gases and repealing Regulation (EC) No 842/2006

Unit model	Refrigerant type	Refrigerant GWP	No. of circuits	Refrigerant charge circuit 1 (kg)	Refrigerant charge circuit 1 (TCO ₂ Eq)
EWAQ075G-SS	R410A	2087,5	1	8,5	17,7
EWAQ085G-SS	R410A	2087,5	1	10,4	21,7
EWAQ100G-SS	R410A	2087,5	1	10,7	22,3
EWAQ110G-SS	R410A	2087,5	1	11,5	24,0
EWAQ120G-SS	R410A	2087,5	1	12,9	26,9
EWAQ140G-SS	R410A	2087,5	1	14,1	29,4
EWAQ155G-SS	R410A	2087,5	1	13,4	28,0

Unit model	Refrigerant type	Refrigerant GWP	No. of circuits	Refrigerant charge circuit 1 (kg)	Refrigerant charge circuit 1 (TCO ₂ Eq)
EWAQ075G-SR	R410A	2087,5	1	8,5	17,7
EWAQ085G-SR	R410A	2087,5	1	10,4	21,7
EWAQ100G-SR	R410A	2087,5	1	10,7	22,3
EWAQ110G-SR	R410A	2087,5	1	11,5	24,0
EWAQ120G-SR	R410A	2087,5	1	12,9	26,9
EWAQ140G-SR	R410A	2087,5	1	14,1	29,4
EWAQ155G-SR	R410A	2087,5	1	13,4	28,0

Unit model	Refrigerant type	Refrigerant GWP	No. of circuits	Refrigerant charge circuit 1 (kg)	Refrigerant charge circuit 1 (TCO ₂ Eq)
EWAQ080G-XS	R410A	2087,5	1	9,1	19,0
EWAQ090G-XS	R410A	2087,5	1	12,7	26,5
EWAQ105G-XS	R410A	2087,5	1	13,1	27,3
EWAQ115G-XS	R410A	2087,5	1	13,2	27,6
EWAQ130G-XS	R410A	2087,5	1	16,1	33,6
EWAQ150G-XS	R410A	2087,5	1	15,0	31,3

Unit model	Refrigerant type	Refrigerant GWP	No. of circuits	Refrigerant charge circuit 1 (kg)	Refrigerant charge circuit 1 (TCO ₂ Eq)
EWAQ080G-XR	R410A	2087,5	1	9,1	19,0
EWAQ090G-XR	R410A	2087,5	1	12,7	26,5
EWAQ105G-XR	R410A	2087,5	1	13,1	27,3
EWAQ115G-XR	R410A	2087,5	1	13,2	27,6
EWAQ130G-XR	R410A	2087,5	1	16,1	33,6
EWAQ150G-XR	R410A	2087,5	1	15,0	31,3

Note: Equipment contains fluorinated greenhouse gases. Actual refrigerant charge depends on the final unit construction, details can be found on the unit labels.

Standard Options (supplied on basic unit)

Direct on line starter (DOL)

Double setpoint - Dual leaving water temperature setpoints.

20mm evaporator insulation - The external shell is covered with a 20mm closed cell insulation material.

Evaporator electric heater - Electric heater (controlled by a thermostat) to protect the evaporator from freezing down to -28°C ambient temperature, providing the power supply is on.

Electronic expansion valve

Ambient outside temperature sensor and setpoint reset

General fault contactor

Hour run meter

Main switch interlock door

Master / Slave – sequencing control that allow to connect up to 4 units in order to coordinate the operation of the chillers working as a bigger unit with multiple circuits.

Evaporator victaulic kit – Hydraulic joint with gasket for an easy and quick water connection.

Options (on request)

MECHANICAL

Evaporator flow switch*

Water filter* - Supplied separately removes impurities from water by means of a fine physical barrier. **Partial heat recovery** - Plate to plate heat exchangers for hot water production.

Total heat recovery - Plate to plate heat exchangers for hot water production.
 - Not available for model EWAQ075GSS/R if option double centrifugal pump + tank is selected

Brine version – Allows the unit to operate down to -10°C leaving liquid temperature (antifreeze required). Required below +4°C

Coil Guards protective grid that covers the access around the unit.

Suction and Discharge line shut - off valve - Installed to facilitate maintenance operation.

High and low pressure side manometers

One centrifugal pump (low lift) - Hydronic kit consists of: single direct driven centrifugal pump, pressure gauge, safety valve, drain valve. The motor pump is protected by a circuit breaker installed in control panel. The kit is assembled and wired to the control panel. The pipe and pump are protected from freezing with an additional electrical heater.

One centrifugal pump (high lift) Hydronic kit consists of: single direct driven centrifugal pump, pressure gauge, safety valve, drain valve. The motor pump is protected by a circuit breaker installed in control panel. The kit is assembled and wired to the control panel. The pipe and pump are protected from freezing with an additional electrical heater.

Two centrifugal pump (low lift) - Hydronic kit consists of: twin direct driven centrifugal pumps, pressure gauge, safety valve, drain valve. The motor pump is protected by a circuit breaker installed in control panel. The kit is assembled and wired to the control panel. The pipe and pumps are protected from freezing with an additional electrical heater.

Two centrifugal pump (high lift) Hydronic kit consists of: twin direct driven centrifugal pumps, pressure gauge, safety valve, drain valve. The motor pump is protected by a circuit breaker installed in control panel. The kit is assembled and wired to the control panel. The pipe and pumps are protected from freezing with an additional electrical **heater**.

E-COATING an uniform layer of an epoxy polymers is applied all over the exchanger surface by electro coating process. The treatment ensure enhanced resistance to corrosion. The E-COATING treatment is recommended for application in potentially corrosive environment such as high polluted urban, coastal, industrial or combinations of those.

Inertial tank (installed on board) All the Hydronic kit are available with inertial tank installed on board. The tank capacities are the follow:

Standard efficiency version

size from 075 tank volume 70* liters
 size from 085 to 110 - tank volume 145 liters
 size from 120 to 155 – tank volume 190 liters

note: for EWAQ075G-SS/R with opt. Two centrifugal pump + tank the tank volume is 50 liters.

High efficiency version

size from 080 - tank volume 145 liters
 size from 090 to 150 – tank volume 190 liters

Double pressure relief valve with diverter

(* Note: the installation is mandatory

ELECTRICAL / CONTROL

Controller expansion pack including :

Under / Over voltage control - Electronic device that monitors and displays input voltage and stops the chiller in case of phase loss, wrong phase sequence or voltage exceeding minimum and maximum allowed values.

Setpoint reset, Demand limit and Alarm from external device, Setpoint Reset : The leaving water temperature set - point can be overwritten with an external 4 - 20mA, through the ambient temperature or through the evaporator water temperature deltaT. Demand Limit: Chiller capacity can be limited through an external 4 - 20mA signal or via network. Alarm from external device: The unit controller is able to receive an external alarm signal. The user can decide whether this alarm signal will stop the unit or not.

Capacitors for power factor correction - Devices that increase the power factor of the unit. The capacitors are “dry” self - regenerating type with over pressure disconnecting safety device insulated with a no toxic dielectric mix without PCB or PCT.

Compressors circuit breakers - Safety devices that include in a single device all safety functions otherwise provided by standard fuses and optional thermal relays, such as protection against overcurrent, overload, current unbalance.

Fans circuit breakers - Safety devices that, added to the standard protection devices. One circuit breaker protect all the fan motors against overload and overcurrent.

INSTALLATION

Rubber anti vibration mounts - Supplied separately, these are positioned under the base of the unit during installation. Ideal to reduce the vibrations when the unit is floor mounted.

Spring anti vibration mounts - Supplied separately, these are positioned under the base of the unit during installation. Ideal for dampening vibrations for installation on roofs and metallic structures.

External tank without cabinet (500 L)

External tank without cabinet (1000 L)

External tank with cabinet (500 L)

External tank with cabinet (1000 L)

- Note: the power supply for the electric heater for the tank is not provided by the unit

OTHER

Container Kit

Witness test

Acoustic test

EWA	Q	120	G	-	S	S
-----	---	-----	---	---	---	---

Machine type

EWA = Air Cooled chiller cooling only

Refrigerant

Q = R410a

Capacity class in kW (Cooling)

Always 3-digit code

Model series

G = single circuit

Inverter

- = no Inverter

Efficiency level

S = Standard Efficiency
X = High efficiency

Sound level

S = Standard noise
R = Reduced noise

EWAQ~G-SS

MODEL		075	085	100	110	120	140
COOLING PERFORMANCE							
Capacity - Cooling(1)	kW	74.7	84.2	96.7	107	117	139
Capacity Control - Type		Step	Step	Step	Step	Step	Step
Capacity Control - Minimum capacity	%	50	44	50	44	50	43
Unit power input - Cooling(1)	kW	27.7	31.2	35.0	39.5	43.4	51.1
EER(1)		2.70	2.70	2.76	2.70	2.70	2.73
ESEER		4.11	4.23	4.04	4.12	3.91	4.20
IPLV		4.79	4.97	4.78	4.86	4.66	4.92
CASING							
Colour(2)		IW	IW	IW	IW	IW	IW
Material(2)		GPSS	GPSS	GPSS	GPSS	GPSS	GPSS
DIMENSIONS							
Height	mm	1800	1800	1800	1800	1800	1800
Width	mm	1195	1195	1195	1195	1195	1195
Length	mm	2140	2680	2680	2680	3200	3200
WEIGHT							
Unit Weight	kg	681	792	923	953	982	1037
Operating Weight	kg	692	802	934	963	993	1054
WATER HEAT EXCHANGER							
Type(3)		BPHE	BPHE	BPHE	BPHE	BPHE	BPHE
Water Volume	l	5.60	4.90	4.90	5.60	5.60	8.10
Nominal water flow rate	l/s	3.6	4.0	4.6	5.1	5.6	6.7
Nominal Water pressure drop	kPa	15.5	27.3	36.9	31.6	36.0	27.5
Insulation material(4)		CC	CC	CC	CC	CC	CC
AIR HEAT EXCHANGER							
Type(5)		microchannel	microchannel	microchannel	microchannel	microchannel	microchannel
FAN							
Type(6)		DPT	DPT	DPT	DPT	DPT	DPT
Drive(7)		DOL	DOL	DOL	DOL	DOL	DOL
Diameter	mm	450	450	450	450	450	450
Nominal air flow	l/s	6017	6444	9029	9029	9029	12008
Quantity	No.	4	4	6	6	6	8
Speed	rpm	1360	1360	1360	1360	1360	1360
Motor input	kW	1.8	1.8	2.7	2.7	2.7	3.6
COMPRESSOR							
Type		Scroll	Scroll	Scroll	Scroll	Scroll	Scroll
Oil charge	l	6.76	8.05	9.34	11.4	13.6	13.6
Quantity	No.	2	2	2	2	2	2
SOUND LEVEL(8)							
Sound power - Cooling	dB(A)	83	85	87	89	89	89
Sound pressure - Cooling	dB(A)	66	68	69	71	71	71
REFRIGERANT CIRCUIT							
Refrigerant type		R410A	R410A	R410A	R410A	R410A	R410A
Refrigerant charge	kg	9	10	11	12	13	14
N. of circuits	No.	1	1	1	1	1	1
PIPING CONNECTIONS							
Evaporator water inlet/outlet	mm	2"1/2	2"1/2	2"1/2	2"1/2	2"1/2	2"1/2

Fluid: Water

(1) Cooling capacity, unit power input in cooling and EER are based on the following conditions: evaporator 12.0/7.0°C; ambient 35.0°C, unit at full load operation;

(2) IW: Ivory White; GPSS: Galvanized and Painted Steel Sheet; (3) PHE: Plate Heat Exchanger --- S&T: Single Pass Shell & Tube

(4) CC: Closed Cell; (5) HFP: High efficiency fin and tube type with integral subcooler

(6) DPT: Direct Propeller Type; (7) DOL: Direct On Line - VFD: Inverter - BRS: Brushless

(8) Details on measurement methods are available in the Sound Data section

Unit performances are referred to ideal running conditions that are reproducible in laboratory test environment in accordance to recognized industry standards (i.e. EN14511). Weights and dimensions are indicative –For specific values refer to certified drawing issued by factory.

Data are referred to unit with standard options only. For specific information about additional options refer to databook specific section.

EWAQ~G-SS

MODEL		155
COOLING PERFORMANCE		
Capacity - Cooling(1)	kW	154
Capacity Control - Type		Step
Capacity Control - Minimum capacity	%	50
Unit power input - Cooling(1)	kW	57.2
EER(1)		2.70
ESEER		4.06
IPLV		4.78
CASING		
Colour(2)		IW
Material(2)		GPSS
DIMENSIONS		
Height	mm	1800
Width	mm	1195
Length	mm	3200
WEIGHT		
Unit Weight	kg	1066
Operating Weight	kg	1085
WATER HEAT EXCHANGER		
Type(3)		BPHE
Water Volume	l	9.40
Nominal water flow rate	l/s	7.4
Nominal Water pressure	kPa	25.8
drop Insulation material(4)		CC
AIR HEAT EXCHANGER		
Type(5)		microchannel
FAN		
Type(6)		DPT
Drive(7)		DOL
Diameter	mm	450
Nominal air flow	l/s	12008
Quantity	No.	8
Speed	rpm	1360
Motor input	kW	3.6
COMPRESSOR		
Type		Scroll
Oil charge	l	13.6
Quantity	No.	2
SOUND LEVEL(8)		
Sound power - Cooling	dB(A)	89
Sound pressure - Cooling	dB(A)	71
REFRIGERANT		
CIRCUIT Refrigerant		R410A
type Refrigerant charge	kg	13
N. of circuits	No.	1
PIPING CONNECTIONS		
Evaporator water inlet/outlet	mm	2"1/2

Fluid: Water

(1) Cooling capacity, unit power input in cooling and EER are based on the following conditions: evaporator 12.0/7.0°C; ambient 35.0°C, unit at full load operation;

(2) IW: Ivory White; GPSS: Galvanized and Painted Steel Sheet; (3) PHE: Plate Heat Exchanger --- S&T: Single Pass Shell & Tube

(4) CC: Closed Cell; (5) HFP: High efficiency fin and tube type with integral subcooler

(6) DPT: Direct Propeller Type; (7) DOL: Direct On Line - VFD: Inverter - BRS: Brushless

(8) Details on measurement methods are available in the Sound Data section

Unit performances are referred to ideal running conditions that are reproducible in laboratory test environment in accordance to recognized industry standards (i.e. EN14511). Weights and dimensions are indicative –For specific values refer to certified drawing issued by factory.

Data are referred to unit with standard options only. For specific information about additional options refer to databook specific section.

EWAQ~G-SR

MODEL		075	085	100	110	120	140
COOLING PERFORMANCE							
Capacity - Cooling(1)	kW	69.	78.	91.	99.	109	130
Capacity Control - Type		3	9	0	7	Ste	Ste
Capacity Control - Minimum capacity	%	Ste	Ste	Ste	Ste	p	p
Unit power input - Cooling(1)	kW	p	p	p	p	50	43
EER(1)		50	44	50	44		
ESEER		29.4	33.1	36.8	42.0	46.3	54.0
IPLV		2.36	2.38	2.47	2.38	2.35	2.42
						3.74	4.12
CASING							
Colour(2)		IW	IW	IW	IW	IW	IW
Material(2)		GPSS	GPSS	GPSS	GPSS	GPSS	GPSS
DIMENSIONS							
Height	mm	1800	1800	1800	1800	1800	1800
Width	mm	1195	1195	1195	1195	1195	1195
Length	mm	2140	2680	2680	2680	3200	3200
WEIGHT							
Unit Weight	kg	711	822	953	983	1012	1067
Operating Weight	kg	722	832	964	993	1023	1084
WATER HEAT EXCHANGER							
Type(3)		BPHE	BPHE	BPHE	BPHE	BPHE	BPHE
Water Volume	l	5.58	4.86	4.86	5.60	5.60	8.10
Nominal water flow rate	l/s	3.3	3.8	4.4	4.8	5.2	6.2
Nominal Water pressure drop	kPa	13.3	24.0	32.6	27.6	31.1	24.1
Insulation material(4)		CC	CC	CC	CC	CC	CC
AIR HEAT EXCHANGER							
Type(5)		microchannel	microchannel	microchannel	microchannel	microchannel	microchannel
FAN							
Type(6)		DPT	DPT	DPT	DPT	DPT	DPT
Drive(7)		DOL	DOL	DOL	DOL	DOL	DOL
Diameter	mm	450	450	450	450	450	450
Nominal air flow	l/s	4523	5046	6787	6787	6787	9023
Quantity	No.	4	4	6	6	6	8
Speed	rpm	1108	1108	1108	1108	1108	1108
Motor input	kW	1.4	1.4	2.0	2.0	2.0	2.7
COMPRESSOR							
Type		Scroll	Scroll	Scroll	Scroll	Scroll	Scroll
Oil charge	l	6.76	8.05	9.34	11.4	13.6	13.6
Quantity	No.	2	2	2	2	2	2
SOUND LEVEL(8)							
Sound power - Cooling	dB(A)	79	82	84	86	86	86
Sound pressure - Cooling	dB(A)	62	65	66	68	68	68
REFRIGERANT CIRCUIT							
Refrigerant type		R410A	R410A	R410A	R410A	R410A	R410A
Refrigerant charge	kg	9	10	11	12	13	14
N. of circuits	No.	1	1	1	1	1	1
PIPING CONNECTIONS							
Evaporator water inlet/outlet	mm	2"1/2	2"1/2	2"1/2	2"1/2	2"1/2	2"1/2

Fluid: Water

(1) Cooling capacity, unit power input in cooling and EER are based on the following conditions: evaporator 12.0/7.0°C; ambient 35.0°C, unit at full load operation;

(2) IW: Ivory White; GPSS: Galvanized and Painted Steel Sheet; (3) PHE: Plate Heat Exchanger --- S&T: Single Pass Shell & Tube

(4) CC: Closed Cell; (5) HFP: High efficiency fin and tube type with integral subcooler

(6) DPT: Direct Propeller Type; (7) DOL: Direct On Line - VFD: Inverter - BRS: Brushless

(8) Details on measurement methods are available in the Sound Data section

Unit performances are referred to ideal running conditions that are reproducible in laboratory test environment in accordance to recognized industry standards (i.e. EN14511). Weights and dimensions are indicative –For specific values refer to certified drawing issued by factory.

Data are referred to unit with standard options only. For specific information about additional options refer to databook specific section.

EWAQ~G-SR

MODEL		155
COOLING PERFORMANCE		
Capacity - Cooling(1)	kW	143
Capacity Control - Type		Step
Capacity Control - Minimum capacity	%	50
Unit power input - Cooling(1)	kW	61.2
EER(1)		2.34
ESEER		3.88
IPLV		4.61
CASING		
Colour(2)		IW
Material(2)		GPSS
DIMENSIONS		
Height	mm	1800
Width	mm	1195
Length	mm	3200
WEIGHT		
Unit Weight	kg	1096
Operating Weight	kg	1115
WATER HEAT EXCHANGER		
Type(3)		BPHE
Water Volume	l	9.36
Nominal water flow rate	l/s	6.9
Nominal Water pressure	kPa	22.2
drop Insulation material(4)		CC
AIR HEAT EXCHANGER		
Type(5)		microchannel
FAN		
Type(6)		DPT
Drive(7)		DOL
Diameter	mm	450
Nominal air flow	l/s	9023
Quantity	No.	8
Speed	rpm	1108
Motor input	kW	2.7
COMPRESSOR		
Type		Scroll
Oil charge	l	13.6
Quantity	No.	2
SOUND LEVEL(8)		
Sound power - Cooling	dB(A)	86
Sound pressure - Cooling	dB(A)	68
REFRIGERANT		
CIRCUIT Refrigerant		R410A
type Refrigerant charge	kg	13
N. of circuits	No.	1
PIPING CONNECTIONS		
Evaporator water inlet/outlet	mm	2"1/2

Fluid: Water

(1) Cooling capacity, unit power input in cooling and EER are based on the following conditions: evaporator 12.0/7.0°C; ambient 35.0°C, unit at full load operation;

(2) IW: Ivory White; GPSS: Galvanized and Painted Steel Sheet; (3) PHE: Plate Heat Exchanger --- S&T: Single Pass Shell & Tube

(4) CC: Closed Cell; (5) HFP: High efficiency fin and tube type with integral subcooler

(6) DPT: Direct Propeller Type; (7) DOL: Direct On Line - VFD: Inverter - BRS: Brushless

(8) Details on measurement methods are available in the Sound Data section

Unit performances are referred to ideal running conditions that are reproducible in laboratory test environment in accordance to recognized industry standards (i.e. EN14511). Weights and dimensions are indicative –For specific values refer to certified drawing issued by factory.

Data are referred to unit with standard options only. For specific information about additional options refer to databook specific section.

EWAQ~G-XS

MODEL		080	090	105	115	130	150
COOLING PERFORMANCE							
Capacity - Cooling(1)	kW	79.8	90.3	105	117	131	149
Capacity Control - Type		Step	Step	Step	Step	Step	Step
Capacity Control - Minimum capacity	%	50	44	50	44	50	43
Unit power input - Cooling(1)	kW	25.8	29.0	33.8	37.7	42.3	48.1
EER(1)		3.10	3.11	3.12	3.10	3.10	3.10
ESEER		4.20	4.30	4.28	4.34	4.22	4.36
IPLV		4.82	5.04	4.96	5.02	4.92	5.05
CASING							
Colour(2)		IW	IW	IW	IW	IW	IW
Material(2)		GPSS	GPSS	GPSS	GPSS	GPSS	GPSS
DIMENSIONS							
Height	mm	1800	1800	1800	1800	1820	1820
Width	mm	1195	1195	1195	1195	1195	1195
Length	mm	2680	3200	3200	3200	3800	3800
WEIGHT							
Unit Weight	kg	734	850	987	1024	1086	1123
Operating Weight	kg	744	860	1002	1040	1102	1144
WATER HEAT EXCHANGER							
Type(3)		BPHE	BPHE	BPHE	BPHE	BPHE	BPHE
Water Volume	l	5.58	4.86	4.86	5.60	5.60	8.10
Nominal water flow rate	l/s	3.8	4.3	5.0	5.6	6.3	7.1
Nominal Water pressure drop	kPa	25.7	32.7	20.3	19.9	25.4	20.6
Insulation material(4)		CC	CC	CC	CC	CC	CC
AIR HEAT EXCHANGER							
Type(5)		microchannel	microchannel	microchannel	microchannel	microchannel	microchannel
FAN							
Type(6)		DPT	DPT	DPT	DPT	DPT	DPT
Drive(7)		DOL	DOL	DOL	DOL	DOL	DOL
Diameter	mm	450	450	450	450	450	450
Nominal air flow	l/s	9029	9498	12008	12008	15046	15046
Quantity	No.	6	6	8	8	10	10
Speed	rpm	1360	1360	1360	1360	1360	1360
Motor input	kW	2.7	2.7	3.6	3.6	4.5	4.5
COMPRESSOR							
Type		Scroll	Scroll	Scroll	Scroll	Scroll	Scroll
Oil charge	l	6.76	8.05	9.34	11.4	13.6	13.6
Quantity	No.	2	2	2	2	2	2
SOUND LEVEL(8)							
Sound power - Cooling	dB(A)	84	85	87	89	89	71
Sound pressure - Cooling	dB(A)	66	68	69	71	71	71
REFRIGERANT CIRCUIT							
Refrigerant type		R410A	R410A	R410A	R410A	R410A	R410A
Refrigerant charge	kg	9	13	13	13	16	15
N. of circuits	No.	1	1	1	1	1	1
PIPING CONNECTIONS							
Evaporator water inlet/outlet	mm	2"1/2	2"1/2	2"1/2	2"1/2	2"1/2	2"1/2

Fluid: Water

(1) Cooling capacity, unit power input in cooling and EER are based on the following conditions: evaporator 12.0/7.0°C; ambient 35.0°C, unit at full load operation;

(2) IW: Ivory White; GPSS: Galvanized and Painted Steel Sheet; (3) PHE: Plate Heat Exchanger --- S&T: Single Pass Shell & Tube

(4) CC: Closed Cell; (5) HFP: High efficiency fin and tube type with integral subcooler

(6) DPT: Direct Propeller Type; (7) DOL: Direct On Line - VFD: Inverter - BRS: Brushless

(8) Details on measurement methods are available in the Sound Data section

Unit performances are referred to ideal running conditions that are reproducible in laboratory test environment in accordance to recognized industry standards (i.e. EN14511). Weights and dimensions are indicative –For specific values refer to certified drawing issued by factory.

Data are referred to unit with standard options only. For specific information about additional options refer to databook specific section.

EWAQ~G-XR

MODEL		080	090	105	115	130	150
COOLING PERFORMANCE							
Capacity - Cooling(1)	kW	76.0	86.0	100	110	125	141
Capacity Control - Type		Step	Step	Step	Step	Step	Step
Capacity Control - Minimum capacity	%	50	44	50	44	50	43
Unit power input - Cooling(1)	kW	26.4	29.9	34.7	39.0	43.3	49.8
EER(1)		2.88	2.88	2.89	2.83	2.88	2.83
ESEER		4.18	4.29	4.27	4.31	4.21	4.33
IPLV		4.85	4.99	4.93	4.99	4.89	5.03
CASING							
Colour(2)		IW	IW	IW	IW	IW	IW
Material(2)		GPSS	GPSS	GPSS	GPSS	GPSS	GPSS
DIMENSIONS							
Height	mm	1800	1800	1800	1800	1820	1820
Width	mm	1195	1195	1195	1195	1195	1195
Length	mm	2680	3200	3200	3200	3800	3800
WEIGHT							
Unit Weight	kg	764	880	1017	1054	1116	1153
Operating Weight	kg	774	890	1032	1070	1132	1174
WATER HEAT EXCHANGER							
Type(3)		BPHE	BPHE	BPHE	BPHE	BPHE	BPHE
Water Volume	l	5.58	4.86	4.86	5.60	5.60	8.10
Nominal water flow rate	l/s	3.6	4.1	4.8	5.3	6.0	6.7
Nominal Water pressure drop	kPa	23.3	29.6	18.4	17.8	23.0	18.4
Insulation material(4)		CC	CC	CC	CC	CC	CC
AIR HEAT EXCHANGER							
Type(5)		microchannel	microchannel	microchannel	microchannel	microchannel	microchannel
FAN							
Type(6)		DPT	DPT	DPT	DPT	DPT	DPT
Drive(7)		DOL	DOL	DOL	DOL	DOL	DOL
Diameter	mm	450	450	450	450	450	450
Nominal air flow	l/s	6787	7356	9023	9023	11309	11309
Quantity	No.	6	6	8	8	10	10
Speed	rpm	1108	1108	1108	1108	1108	1108
Motor input	kW	2.0	2.0	2.7	2.7	3.4	3.4
COMPRESSOR							
Type		Scroll	Scroll	Scroll	Scroll	Scroll	Scroll
Oil charge	l	6.76	8.05	9.34	11.4	13.6	13.6
Quantity	No.	2	2	2	2	2	2
SOUND LEVEL(8)							
Sound power - Cooling	dB(A)	80	82	84	86	86	86
Sound pressure - Cooling	dB(A)	62	65	66	68	67	67
REFRIGERANT CIRCUIT							
Refrigerant type		R410A	R410A	R410A	R410A	R410A	R410A
Refrigerant charge	kg	9	13	13	13	16	15
N. of circuits	No.	1	1	1	1	1	1
PIPING CONNECTIONS							
Evaporator water inlet/outlet	mm	2"1/2	2"1/2	2"1/2	2"1/2	2"1/2	2"1/2

Fluid: Water

(1) Cooling capacity, unit power input in cooling and EER are based on the following conditions: evaporator 12.0/7.0°C; ambient 35.0°C, unit at full load operation;

(2) IW: Ivory White; GPSS: Galvanized and Painted Steel Sheet; (3) PHE: Plate Heat Exchanger --- S&T: Single Pass Shell & Tube

(4) CC: Closed Cell; (5) HFP: High efficiency fin and tube type with integral subcooler

(6) DPT: Direct Propeller Type; (7) DOL: Direct On Line - VFD: Inverter - BRS: Brushless

(8) Details on measurement methods are available in the Sound Data section

Unit performances are referred to ideal running conditions that are reproducible in laboratory test environment in accordance to recognized industry standards (i.e. EN14511). Weights and dimensions are indicative –For specific values refer to certified drawing issued by factory.

Data are referred to unit with standard options only. For specific information about additional options refer to databook specific section.

EWAQ~G-SS

MODEL		075	085	100	110	120	140
POWER SUPPLY							
Phases	No.	3	3	3	3	3	3
Frequency	Hz	50	50	50	50	50	50
Voltage	V	400	400	400	400	400	400
Voltage tolerance minimum	%	-10%	-10%	-10%	-10%	-10%	-10%
Voltage tolerance maximum	%	10%	10%	10%	10%	10%	10%
UNIT							
Maximum starting current	A	211	262	270	317	325	365
Nominal running current cooling	A	54	58	62	70	79	89
Maximum running current	A	68	74	81	89	97	114
Maximum current for wires sizing	A	75	81	89	98	107	125
FANS							
Nominal running current cooling	A	4	4	6	6	6	8
COMPRESSORS							
Phases	No.	3	3	3	3	3	3
Voltage	V	400	400	400	400	400	400
Voltage tolerance minimum	%	-10%	-10%	-10%	-10%	-10%	-10%
Voltage tolerance maximum	%	10%	10%	10%	10%	10%	10%
Maximum running current	A	62	67	73	81	89	104
Starting method		DOL	DOL	DOL	DOL	DOL	DOL

MODEL		155
POWER SUPPLY		
Phases	No.	3
Frequency	Hz	50
Voltage	V	400
Voltage tolerance minimum	%	-10%
Voltage tolerance maximum	%	10%
UNIT		
Maximum starting current	A	379
Nominal running current cooling	A	102
Maximum running current	A	129
Maximum current for wires sizing	A	142
FANS		
Nominal running current cooling	A	8
COMPRESSORS		
Phases	No.	3
Voltage	V	400
Voltage tolerance minimum	%	-10%
Voltage tolerance maximum	%	10%
Maximum running current	A	119
Starting method		DOL

Fluid: Water

Allowed voltage tolerance $\pm 10\%$. Voltage unbalance between phases must be within $\pm 3\%$.

Maximum starting current: starting current of biggest compressor + current of the other compressors at maximum load + fans current at maximum load. In case of inverter driven units, no inrush current at start up is experienced.

Nominal current in cooling mode is referred to the following conditions: evaporator 12/7°C; ambient 35°C; compressors + fans current.

Maximum running current is based on max compressor absorbed current in its envelope and max fans absorbed current

Maximum unit current for wires sizing is based on minimum allowed voltage

Maximum current for wires sizing: (Maximum running current) $\times 1,1$.

EWAQ~G-SR

MODEL		075	085	100	110	120	140
POWER SUPPLY							
Phases	No.	3	3	3	3	3	3
Frequency	Hz	50	50	50	50	50	50
Voltage	V	400	400	400	400	400	400
Voltage tolerance minimum	%	-10%	-10%	-10%	-10%	-10%	-10%
Voltage tolerance maximum	%	10%	10%	10%	10%	10%	10%
UNIT							
Maximum starting current	A	211	262	270	317	325	365
Nominal running current cooling	A	57	61	65	74	84	93
Maximum running current	A	68	74	81	89	97	114
Maximum current for wires sizing	A	75	81	89	98	107	125
FANS							
Nominal running current cooling	A	4	4	6	6	6	8
COMPRESSORS							
Phases	No.	3	3	3	3	3	3
Voltage	V	400	400	400	400	400	400
Voltage tolerance minimum	%	-10%	-10%	-10%	-10%	-10%	-10%
Voltage tolerance maximum	%	10%	10%	10%	10%	10%	10%
Maximum running current	A	62	67	73	81	89	104
Starting method		DOL	DOL	DOL	DOL	DOL	DOL

MODEL		155
POWER SUPPLY		
Phases	No.	3
Frequency	Hz	50
Voltage	V	400
Voltage tolerance minimum	%	-10%
Voltage tolerance maximum	%	10%
UNIT		
Maximum starting current	A	379
Nominal running current cooling	A	109
Maximum running current	A	129
Maximum current for wires sizing	A	142
FANS		
Nominal running current cooling	A	8
COMPRESSORS		
Phases	No.	3
Voltage	V	400
Voltage tolerance minimum	%	-10%
Voltage tolerance maximum	%	10%
Maximum running current	A	119
Starting method		DOL

Fluid: Water

Allowed voltage tolerance $\pm 10\%$. Voltage unbalance between phases must be within $\pm 3\%$.

Maximum starting current: starting current of biggest compressor + current of the other compressors at maximum load + fans current at maximum load. In case of inverter driven units, no inrush current at start up is experienced.

Nominal current in cooling mode is referred to the following conditions: evaporator 12/7°C; ambient 35°C; compressors + fans current.

Maximum running current is based on max compressor absorbed current in its envelope and max fans absorbed current

Maximum unit current for wires sizing is based on minimum allowed voltage

Maximum current for wires sizing: (Maximum running current) $\times 1,1$.

EWAQ~G-XS

MODEL		080	090	105	115	130	150
POWER SUPPLY							
Phases	No.	3	3	3	3	3	3
Frequency	Hz	50	50	50	50	50	50
Voltage	V	400	400	400	400	400	400
Voltage tollerance minimum	%	-10%	-10%	-10%	-10%	-10%	-10%
Voltage tollerance maximum	%	10%	10%	10%	10%	10%	10%
UNIT							
Maximum starting current	A	213	264	272	319	329	367
Nominal running current cooling	A	52	56	61	69	76	87
Maximum running current	A	70	75	83	91	101	116
Maximum current for wires sizing	A	77	83	91	100	111	128
FANS							
Nominal running current cooling	A	6	6	8	8	10	10
COMPRESSORS							
Phases	No.	3	3	3	3	3	3
Voltage	V	400	400	400	400	400	400
Voltage tollerance minimum	%	-10%	-10%	-10%	-10%	-10%	-10%
Voltage tollerance maximum	%	10%	10%	10%	10%	10%	10%
Maximum running current	A	62	67	73	81	89	104
Starting method		DOL	DOL	DOL	DOL	DOL	DOL

Fluid: Water

Allowed voltage tolerance $\pm 10\%$. Voltage unbalance between phases must be within $\pm 3\%$.

Maximum starting current: starting current of biggest compressor + current of the other compressors at maximum load + fans current at maximum load. In case of inverter driven units, no inrush current at start up is experienced.

Nominal current in cooling mode is referred to the following conditions: evaporator 12/7°C; ambient 35°C; compressors + fans current.

Maximum running current is based on max compressor absorbed current in its envelope and max fans absorbed current

Maximum unit current for wires sizing is based on minimum allowed voltage

Maximum current for wires sizing: (Maximum running current) $\times 1,1$.

EWAQ~G-XR

MODEL		080	090	105	115	130	150
POWER SUPPLY							
Phases	No.	3	3	3	3	3	3
Frequency	Hz	50	50	50	50	50	50
Voltage	V	400	400	400	400	400	400
Voltage tollerance minimum	%	-10%	-10%	-10%	-10%	-10%	-10%
Voltage tollerance maximum	%	10%	10%	10%	10%	10%	10%
UNIT							
Maximum starting current	A	213	264	272	319	329	367
Nominal running current cooling	A	54	58	63	71	78	90
Maximum running current	A	70	75	83	91	101	116
Maximum current for wires sizing	A	77	83	91	100	111	128
FANS							
Nominal running current cooling	A	6	6	8	8	10	10
COMPRESSORS							
Phases	No.	3	3	3	3	3	3
Voltage	V	400	400	400	400	400	400
Voltage tollerance minimum	%	-10%	-10%	-10%	-10%	-10%	-10%
Voltage tollerance maximum	%	10%	10%	10%	10%	10%	10%
Maximum running current	A	62	67	73	81	89	104
Starting method		DOL	DOL	DOL	DOL	DOL	DOL

Fluid: Water

Allowed voltage tolerance $\pm 10\%$. Voltage unbalance between phases must be within $\pm 3\%$.

Maximum starting current: starting current of biggest compressor + current of the other compressors at maximum load + fans current at maximum load. In case of inverter driven units, no inrush current at start up is experienced.

Nominal current in cooling mode is referred to the following conditions: evaporator 12/7°C; ambient 35°C; compressors + fans current.

Maximum running current is based on max compressor absorbed current in its envelope and max fans absorbed current

Maximum unit current for wires sizing is based on minimum allowed voltage

Maximum current for wires sizing: (Maximum running current) $\times 1,1$.

EWAQ~G-SS

MODEL	Sound pressure level at 1 m from the unit (rif. 2 x 10 ⁻⁵ Pa)									Power db(A)
	63 Hz	125 Hz	250 Hz	500 Hz	1000 Hz	2000 Hz	4000 Hz	8000 Hz	db(A)	
075	75,0	66,0	63,0	65,0	61,0	57,0	51,0	44,0	66	83
085	77,0	68,0	65,0	67,0	63,0	59,0	53,0	46,0	68	85
100	78,0	69,0	67,0	68,0	65,0	61,0	54,0	47,0	69	87
110	80,0	71,0	69,0	70,0	66,0	62,0	56,0	49,0	71	89
120	80,0	71,0	69,0	70,0	67,0	63,0	56,0	49,0	71	89
140	80,0	71,0	68,0	70,0	66,0	62,0	56,0	49,0	71	89
155	80,0	71,0	68,0	70,0	66,0	62,0	56,0	49,0	71	89

Sound power level is measured in accordance with ISO9614 and Eurovent 8/1 and certified by Eurovent. Sound pressure level is calculated from sound power level. Eurovent certification refers to the overall sound power level only. Sound pressure in frequency bands is for information only and not considered binding.

EWAQ~G-SR

MODEL	Sound pressure level at 1 m from the unit (rif. 2 x 10⁻⁵ Pa)									Power db(A)
	63 Hz	125 Hz	250 Hz	500 Hz	1000 Hz	2000 Hz	4000 Hz	8000 Hz	db(A)	
075	68,0	59,0	59,0	61,0	57,0	53,0	45,0	37,0	62	79
085	70,0	62,0	61,0	64,0	60,0	56,0	48,0	39,0	65	82
100	72,0	63,0	63,0	65,0	61,0	58,0	49,0	41,0	66	84
110	73,0	65,0	65,0	67,0	63,0	59,0	51,0	42,0	68	86
120	74,0	65,0	65,0	67,0	63,0	59,0	51,0	43,0	68	86
140	73,0	65,0	64,0	67,0	63,0	59,0	51,0	42,0	68	86
155	73,0	65,0	64,0	67,0	63,0	59,0	51,0	42,0	68	86

Sound power level is measured in accordance with ISO9614 and Eurovent 8/1 and certified by Eurovent. Sound pressure level is calculated from sound power level. Eurovent certification refers to the overall sound power level only. Sound pressure in frequency bands is for information only and not considered binding.

EWAQ~G-XS

MODEL	Sound pressure level at 1 m from the unit (rif. 2 x 10⁻⁵ Pa)									Power db(A)
	63 Hz	125 Hz	250 Hz	500 Hz	1000 Hz	2000 Hz	4000 Hz	8000 Hz	db(A)	
080	75,0	66,0	63,0	64,0	61,0	57,0	50,0	44,0	66	84
090	77,0	67,0	65,0	66,0	63,0	59,0	52,0	45,0	68	85
105	78,0	69,0	67,0	68,0	64,0	60,0	54,0	47,0	69	87
115	80,0	71,0	68,0	69,0	66,0	62,0	55,0	49,0	71	89
130	80,0	70,0	68,0	69,0	66,0	62,0	55,0	48,0	71	89
150	80,0	70,0	68,0	69,0	66,0	62,0	55,0	48,0	71	71

Sound power level is measured in accordance with ISO9614 and Eurovent 8/1 and certified by Eurovent. Sound pressure level is calculated from sound power level. Eurovent certification refers to the overall sound power level only. Sound pressure in frequency bands is for information only and not considered binding.

EWAQ~G-XR

MODEL	Sound pressure level at 1 m from the unit (rif. 2×10^{-5} Pa)									Power db(A)
	63 Hz	125 Hz	250 Hz	500 Hz	1000 Hz	2000 Hz	4000 Hz	8000 Hz	db(A)	
080	68,0	59,0	59,0	61,0	57,0	53,0	45,0	37,0	62	80
090	70,0	62,0	61,0	63,0	60,0	56,0	48,0	39,0	65	82
105	72,0	63,0	63,0	65,0	61,0	57,0	49,0	41,0	66	84
115	73,0	65,0	64,0	66,0	63,0	59,0	51,0	42,0	68	86
130	73,0	65,0	64,0	66,0	63,0	59,0	51,0	42,0	67	86
150	73,0	65,0	64,0	66,0	63,0	59,0	51,0	42,0	67	86

Sound power level is measured in accordance with ISO9614 and Eurovent 8/1 and certified by Eurovent. Sound pressure level is calculated from sound power level. Eurovent certification refers to the overall sound power level only. Sound pressure in frequency bands is for information only and not considered binding.

Operating Limits

EWAQ G SS (Standard efficiency, Standard Noise)

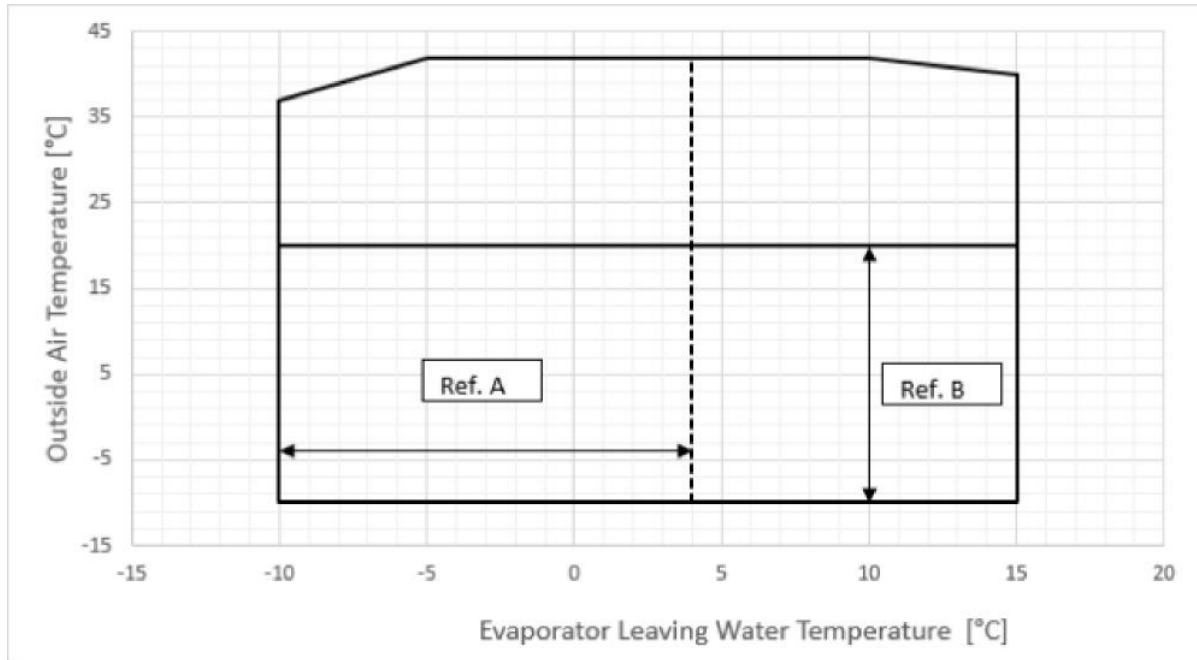

EWAQ G SR (standard efficiency, Reduced Noise)

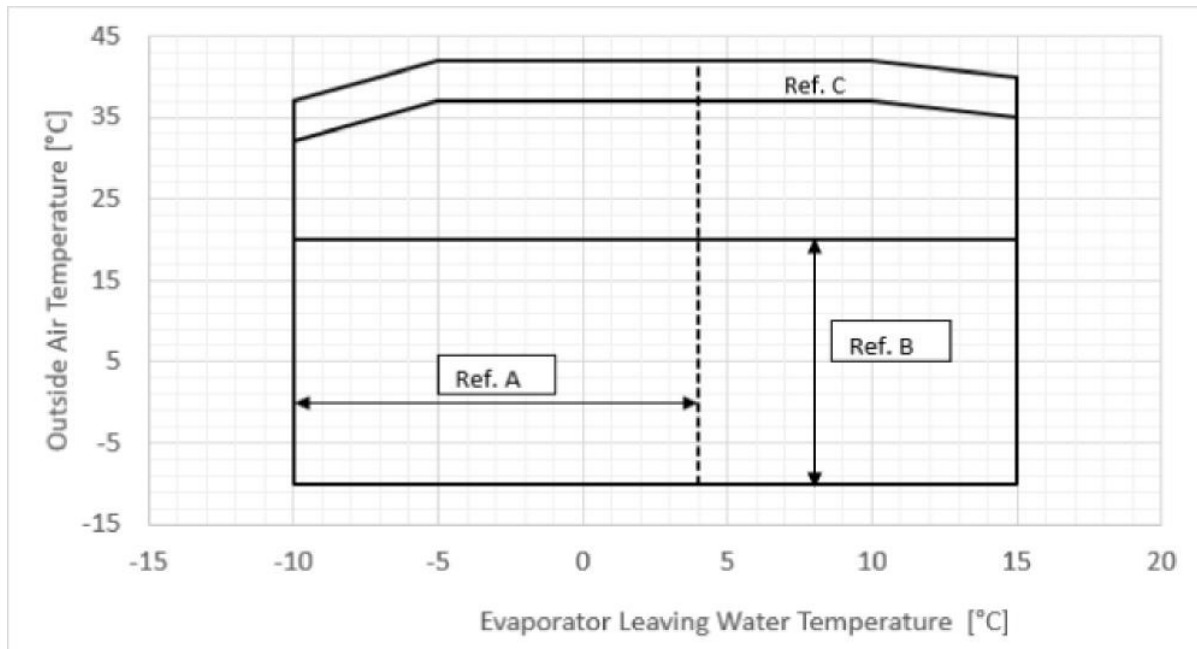

Ref. A: Operation with glycol

Ref. B: operation with fan speed modulation (fan speed modulation provided as standard)

Ref. C: in this area the fan speed increase in order to ensure the functioning of the unit.

Note: The above graphic represents a guidelines about the operating limits of the range. Please refer to Chiller Selection Software (CSS) for real operating limits working conditions for each size. The data are referred to the unit operating without External static pressure available.

EWAQ G XS (High efficiency, Standard Noise)

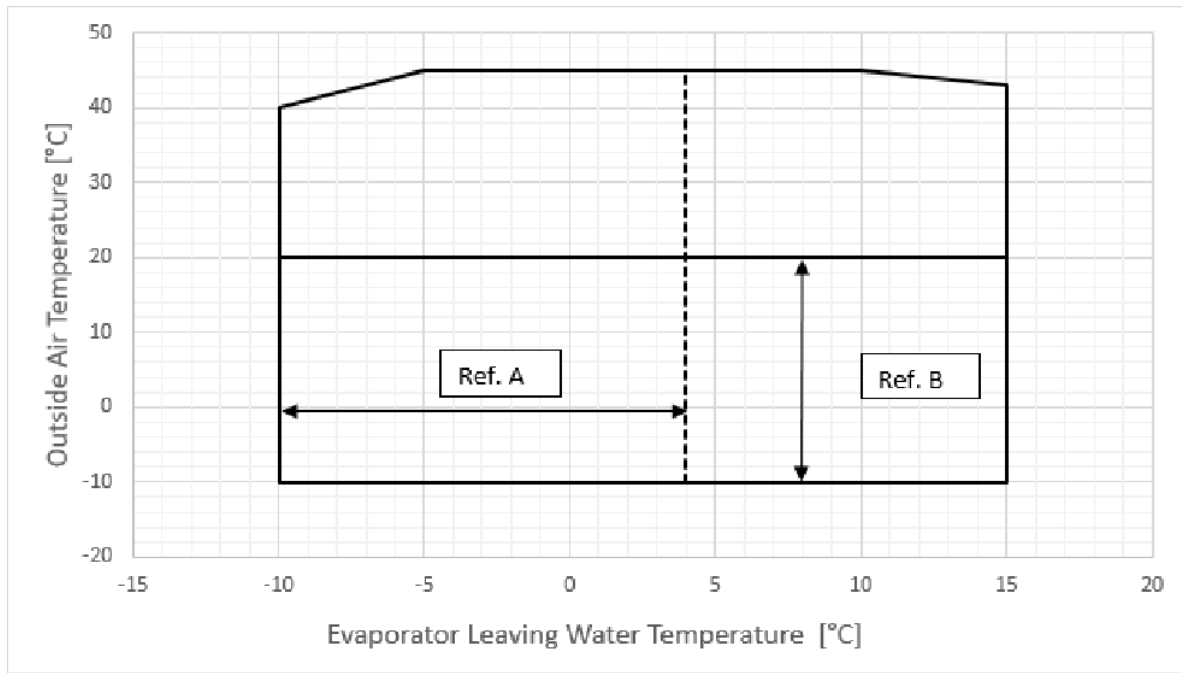

EWAQ G XR (High efficiency, Reduced Noise)

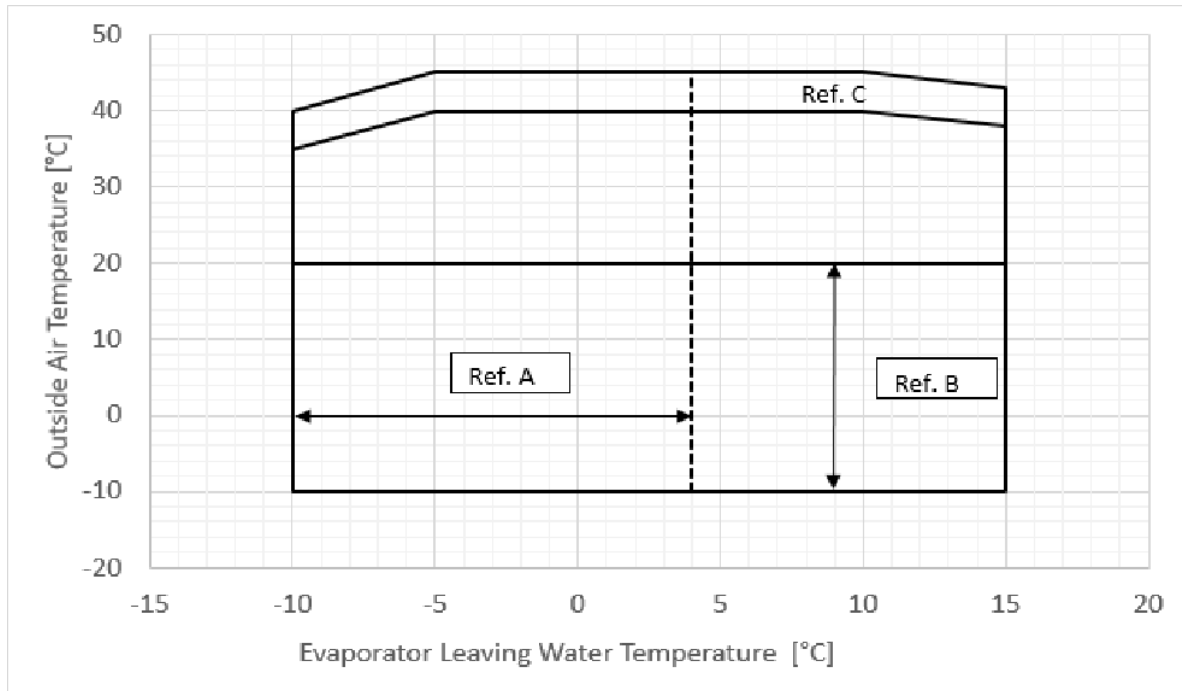

Ref. A: Operation with glycol

Ref. B: operation with fan speed modulation (fan speed modulation provided as standard)

Ref. C: in this area the fan speed increase in order to ensure the functioning of the unit.

Note: The above graphic represents a guidelines about the operating limits of the range. Please refer to Chiller Selection Software (CSS) for real operating limits working conditions for each size.
The data are referred to the unit operating without External static pressure available.

Table 1 - Water heat exchanger - Minimum and maximum water deltaT

A - Δt	°C	8
B - Δt	°C	4

Legend:

A = Max evaporator water deltaT

B = Min evaporator water deltaT

Table 2 - Water heat exchanger - Fouling factors

A	B	C	D
0.0176	1.000	1.000	1.000
0.0440	0.978	0.986	0.992
0.0880	0.957	0.974	0.983
0.1320	0.938	0.962	0.975

Legend:

A = Fouling factors (m² °C / kW)

B = Cooling capacity correction factor

C = Power input correction factor

D = EER correction factor

Table 3 - Air heat exchanger - Altitude correction factors

A	0	300	600	900	1200	1500	1800
B	1013	977	942	908	875	843	812
C	1.000	0.993	0.986	0.979	0.973	0.967	0.960
D	1.000	1.005	1.009	1.015	1.021	1.026	1.031

Legend:

A = Elevation above sea level (m)

B = Barometric pressure (mbar)

C = Cooling capacity correction factor

D = Power input correction factor

- Maximum operating altitude is 2000 m above sea level

- Contact factory in case the unit has to be installed at altitudes between 1000 and 2000 m above sea level

Table 4 - Minimum glycol percentage for low air ambient temperature

	AAT (2)	-3	-8	-15	-20
A (1)		10%	20%	30%	40%
	AAT (2)	-3	-7	-12	-20
B (1)		10%	20%	30%	40%

Legend:

AAT = Air Ambient Temperature (°C) (2)

A = Ethylene glycol (%) (1)

B = Propylene glycol (%) (1)

(1) Minimum glycol percentage to prevent freezing of water circuit at indicated air ambient temperature

(2) Air ambient temperature do exceed the operating limits of the unit, a protection of water circuit may be needed in winter season at non - working conditions.

Water content in cooling circuits The cooled water distribution circuits should have minimum water content to avoid excessive compressors start and stop. In fact, each time the compressor starts up, an excessive quantity of oil goes from the compressor sump and simultaneously there is a rise in the temperature of the compressor motor's stator due to the inrush current during the start - up. To prevent damage to the compressors, have been envisaged the application of a device to limit frequent stops and restarts.

During the span of one hour there will be no more than 10 starts of the compressor. The plant side should therefore ensure that the overall water content allows a more constant functioning of the unit and consequently greater environmental comfort.

The calculation of the water content should also consider the plant's design parameters.

As a general indication the water content should not be less than 4 lt/kW.

Note: The indication is intended as a general guideline and not intended to substitute the evaluation made by qualified technical personnel or by HVAC engineers. For more detailed analysis is better to consider the use of other more detailed approach.

EWAQ~G-SS

		075						085						
Twout	Tain	25	30	35	40	43	46	25	30	35	40	43	46	
5	Pf	kW	83.0	77.0	71.0	65.0	61.5	35.2	93.3	86.6	79.9	73.4	69.7	44.1
	Pa	kW	23.2	25.1	27.2	29.7	31.4	15.2	26.0	28.1	30.6	33.6	35.6	19.5
	qw	l/s	4.0	3.7	3.4	3.1	2.9	1.7	4.5	4.1	3.8	3.5	3.3	2.1
	dpw	kPa	19.1	16.4	13.9	11.7	10.5	3.40	33.5	28.9	24.5	20.7	18.7	7.50
7	Pf	kW	87.2	81.0	74.7	68.6	65.0	37.4	98.0	91.1	84.2	77.5	73.7	47.0
	Pa	kW	23.6	25.5	27.7	30.2	31.9	15.3	26.5	28.7	31.2	34.2	36.3	19.8
	qw	l/s	4.2	3.9	3.6	3.3	3.1	1.8	4.7	4.4	4.0	3.7	3.5	2.2
	dpw	kPa	21.1	18.2	15.5	13.0	11.7	3.90	37.1	32.0	27.3	23.1	20.9	8.50
9	Pf	kW	91.5	85.0	78.5	72.2	68.6	39.6	103	95.7	88.6	81.7	77.8	49.9
	Pa	kW	24.1	26.0	28.2	30.7	32.4	15.5	27.0	29.2	31.8	34.8	36.9	20.0
	qw	l/s	4.4	4.1	3.8	3.5	3.3	1.9	4.9	4.6	4.2	3.9	3.7	2.4
	dpw	kPa	23.3	20.1	17.1	14.5	13.1	4.40	41.0	35.4	30.3	25.8	23.4	9.60
11	Pf	kW	95.9	89.2	82.5	76.0	72.3	42.0	108	100	93.1	86.0	82.1	52.9
	Pa	kW	24.6	26.5	28.7	31.2	32.9	15.7	27.6	29.8	32.4	35.5	37.6	20.3
	qw	l/s	4.6	4.3	4.0	3.6	3.5	2.0	5.2	4.8	4.5	4.1	3.9	2.5
	dpw	kPa	25.6	22.1	18.9	16.1	14.5	4.90	45.1	39.1	33.5	28.6	26.1	10.8
13	Pf	kW	100	93.4	86.5	79.8	46.9	44.5	113	105	97.7	90.4	58.9	56.1
	Pa	kW	25.1	27.0	29.2	31.8	15.1	15.8	28.2	30.5	33.1	36.2	19.5	20.6
	qw	l/s	4.8	4.5	4.2	3.8	2.2	2.1	5.4	5.1	4.7	4.3	2.8	2.7
	dpw	kPa	28.1	24.3	20.9	17.8	6.10	5.50	49.5	43.0	37.0	31.7	13.4	12.2
15	Pf	kW	105	97.8	90.7	83.8	49.6	47.1	118	110	102	95.0	62.2	59.3
	Pa	kW	25.6	27.6	29.8	32.3	15.3	16.0	28.8	31.1	33.8	36.9	19.8	20.9
	qw	l/s	5.0	4.7	4.4	4.0	2.4	2.3	5.7	5.3	4.9	4.6	3.0	2.8
	dpw	kPa	30.8	26.7	22.9	19.6	6.80	6.20	54.3	47.2	40.7	35.0	15.0	13.6

		100						110						
Twout	Tain	25	30	35	40	43	46	25	30	35	40	43	46	
5	Pf	kW	107	99.1	91.6	84.3	80.2	76.4	118	110	101	93.2	88.7	55.4
	Pa	kW	29.3	31.6	34.4	37.7	40.0	42.6	33.0	35.7	38.9	42.5	45.0	24.5
	qw	l/s	5.1	4.7	4.4	4.0	3.8	3.7	5.6	5.2	4.8	4.5	4.2	2.6
	dpw	kPa	44.7	38.7	33.0	28.0	25.3	22.9	38.6	33.3	28.4	24.0	21.7	8.50
7	Pf	kW	112	104	96.7	89.2	84.9	81.0	124	115	107	98.4	93.7	58.9
	Pa	kW	29.8	32.2	35.0	38.3	40.7	43.3	33.6	36.4	39.5	43.2	45.8	24.8
	qw	l/s	5.4	5.0	4.6	4.3	4.1	3.9	5.9	5.5	5.1	4.7	4.5	2.8
	dpw	kPa	49.7	43.1	36.9	31.3	28.4	25.9	42.7	37.0	31.6	26.8	24.4	9.60
9	Pf	kW	118	110	102	94.1	89.8	85.8	130	121	112	104	99.0	62.5
	Pa	kW	30.4	32.8	35.6	39.0	41.3	44.0	34.3	37.0	40.3	44.0	46.5	25.0
	qw	l/s	5.7	5.3	4.9	4.5	4.3	4.1	6.2	5.8	5.4	5.0	4.7	3.0
	dpw	kPa	55.0	47.8	41.0	35.0	31.8	29.1	47.2	40.9	35.1	29.9	27.2	10.8
11	Pf	kW	124	115	107	99.2	94.8	54.8	136	127	118	109	104	66.2
	Pa	kW	31.0	33.4	36.3	39.7	42.1	20.6	34.9	37.7	41.0	44.8	47.4	25.3
	qw	l/s	5.9	5.6	5.2	4.8	4.6	2.6	6.6	6.1	5.7	5.2	5.0	3.2
	dpw	kPa	60.8	52.9	45.5	39.0	35.5	11.8	51.9	45.1	38.8	33.2	30.3	12.2
13	Pf	kW	130	121	113	104	99.9	58.1	143	133	124	115	73.7	70.1
	Pa	kW	31.6	34.1	37.0	40.4	42.8	20.8	35.6	38.5	41.8	45.6	24.4	25.6
	qw	l/s	6.2	5.8	5.4	5.0	4.8	2.8	6.9	6.4	6.0	5.5	3.5	3.4
	dpw	kPa	66.9	58.3	50.4	43.3	39.6	13.3	57.0	49.6	42.8	36.8	15.1	13.7
15	Pf	kW	136	127	118	110	105	61.5	149	139	130	121	77.8	74.1
	Pa	kW	32.3	34.8	37.7	41.2	43.6	21.1	36.4	39.3	42.6	46.4	24.6	25.9
	qw	l/s	6.5	6.1	5.7	5.3	5.1	3.0	7.2	6.7	6.2	5.8	3.7	3.6
	dpw	kPa	73.4	64.2	55.6	47.9	43.9	15.0	62.4	54.4	47.1	40.7	16.9	15.3

EWAQ~G-SS

		120						140						
Twout	Tain	25	30	35	40	43	46	25	30	35	40	43	46	
5	Pf	kW	130	120	111	102	97.4	56.9	154	143	132	122	115	110
	Pa	kW	36.2	39.2	42.6	46.5	49.2	23.6	42.7	46.3	50.3	54.9	58.0	61.5
	qw	l/s	6.2	5.8	5.3	4.9	4.7	2.7	7.4	6.9	6.3	5.8	5.5	5.3
	dpw	kPa	44.2	38.1	32.4	27.5	24.9	8.50	33.7	29.1	24.7	20.9	18.8	17.0
7	Pf	kW	136	126	117	108	103	60.5	162	151	139	128	122	76.9
	Pa	kW	36.9	39.9	43.4	47.3	50.0	23.9	43.5	47.1	51.1	55.8	58.9	32.5
	qw	l/s	6.5	6.1	5.6	5.2	4.9	2.9	7.8	7.2	6.7	6.1	5.8	3.7
	dpw	kPa	48.8	42.1	36.0	30.6	27.8	9.60	37.4	32.3	27.5	23.3	21.1	8.30
9	Pf	kW	143	133	123	114	67.6	64.2	170	159	147	135	129	81.7
	Pa	kW	37.6	40.7	44.1	48.1	23.0	24.1	44.3	47.9	52.0	56.7	59.9	32.9
	qw	l/s	6.8	6.4	5.9	5.4	3.2	3.1	8.2	7.6	7.0	6.5	6.2	3.9
	dpw	kPa	53.7	46.5	39.8	34.0	12.0	10.8	41.3	35.7	30.6	26.0	23.6	9.40
11	Pf	kW	149	139	129	119	71.6	68.0	179	167	154	143	136	86.6
	Pa	kW	38.4	41.4	44.9	49.0	23.2	24.4	45.2	48.8	52.9	57.7	60.9	33.3
	qw	l/s	7.2	6.7	6.2	5.7	3.4	3.3	8.6	8.0	7.4	6.8	6.5	4.1
	dpw	kPa	59.0	51.1	44.0	37.7	13.5	12.2	45.5	39.5	33.9	28.9	26.3	10.6
13	Pf	kW	156	145	135	125	75.7	72.0	187	175	162	150	143	91.6
	Pa	kW	39.1	42.2	45.8	49.9	23.5	24.7	46.1	49.8	53.9	58.7	62.0	33.8
	qw	l/s	7.5	7.0	6.5	6.0	3.6	3.5	9.0	8.4	7.8	7.2	6.9	4.4
	dpw	kPa	64.5	56.1	48.4	41.7	15.1	13.7	50.0	43.5	37.4	32.0	29.2	11.9
15	Pf	kW	163	152	142	132	79.9	76.0	196	183	170	158	102	96.9
	Pa	kW	39.9	43.1	46.7	50.8	23.8	25.0	47.1	50.8	55.0	59.8	32.5	34.2
	qw	l/s	7.8	7.3	6.8	6.3	3.8	3.7	9.4	8.8	8.2	7.6	4.9	4.6
	dpw	kPa	70.5	61.4	53.2	46.0	16.9	15.3	54.8	47.7	41.2	35.4	14.8	13.3

		155						
Twout	Tain	25	30	35	40	43	46	
5	Pf	kW	172	159	147	135	128	73.9
	Pa	kW	47.6	51.6	56.2	61.5	65.2	31.3
	qw	l/s	8.2	7.6	7.0	6.4	6.1	3.5
	dpw	kPa	31.7	27.3	23.2	19.5	17.7	5.90
7	Pf	kW	180	167	154	142	136	78.6
	Pa	kW	48.6	52.6	57.2	62.6	66.3	31.6
	qw	l/s	8.6	8.0	7.4	6.8	6.5	3.8
	dpw	kPa	35.1	30.2	25.8	21.8	19.8	6.70
9	Pf	kW	189	176	162	150	88.1	83.5
	Pa	kW	49.6	53.7	58.3	63.8	30.4	32.0
	qw	l/s	9.1	8.4	7.8	7.2	4.2	4.0
	dpw	kPa	38.7	33.4	28.6	24.3	8.40	7.50
11	Pf	kW	198	184	171	158	93.4	88.6
	Pa	kW	50.7	54.8	59.5	65.0	30.8	32.4
	qw	l/s	9.5	8.8	8.2	7.6	4.5	4.2
	dpw	kPa	42.6	36.8	31.6	27.0	9.40	8.50
13	Pf	kW	207	193	179	166	98.8	93.8
	Pa	kW	51.8	56.0	60.8	66.3	31.2	32.8
	qw	l/s	10	9.3	8.6	8.0	4.7	4.5
	dpw	kPa	46.7	40.5	34.8	29.8	10.6	9.50
15	Pf	kW	217	202	188	174	104	99.2
	Pa	kW	53.0	57.2	62.1	67.8	31.6	33.3
	qw	l/s	10	9.7	9.0	8.4	5.0	4.8
	dpw	kPa	51.1	44.4	38.3	32.9	11.8	10.7

EWAQ~G-SR

		075						085					
Twout	Tain	25	30	35	40	43	46	25	30	35	40	43	46
5	Pf kW	77.7	71.8	65.9	60.3	35.7	33.7	87.9	81.3	74.9	68.9	44.7	42.5
	Pa kW	24.4	26.5	28.8	31.6	14.6	15.4	27.3	29.6	32.4	35.7	18.8	20.0
	qw l/s	3.7	3.4	3.2	2.9	1.7	1.6	4.2	3.9	3.6	3.3	2.1	2.0
	dpw kPa	16.7	14.2	12.0	10.1	3.50	3.10	29.7	25.5	21.6	18.2	7.70	6.90
7	Pf kW	81.4	75.3	69.3	63.6	37.9	35.8	92.2	85.4	78.9	72.7	47.5	45.1
	Pa kW	25.0	27.0	29.4	32.2	14.7	15.5	27.9	30.3	33.1	36.5	19.1	20.2
	qw l/s	3.9	3.6	3.3	3.0	1.8	1.7	4.4	4.1	3.8	3.5	2.3	2.2
	dpw kPa	18.4	15.7	13.3	11.2	4.00	3.50	32.8	28.2	24.0	20.4	8.70	7.80
9	Pf kW	85.2	78.9	72.8	42.3	40.1	38.0	96.6	89.6	82.9	53.0	50.4	47.9
	Pa kW	25.5	27.6	30.0	14.2	14.9	15.7	28.5	31.0	33.8	18.3	19.4	20.6
	qw l/s	4.1	3.8	3.5	2.0	1.9	1.8	4.6	4.3	4.0	2.5	2.4	2.3
	dpw kPa	20.2	17.3	14.7	5.00	4.50	4.00	36.1	31.1	26.5	10.8	9.80	8.80
11	Pf kW	89.1	82.6	76.3	44.7	42.4	40.2	101	93.9	87.0	56.0	53.3	50.8
	Pa kW	26.1	28.2	30.6	14.4	15.1	15.9	29.2	31.7	34.6	18.6	19.7	20.9
	qw l/s	4.3	4.0	3.7	2.1	2.0	1.9	4.9	4.5	4.2	2.7	2.6	2.4
	dpw kPa	22.1	19.0	16.2	5.50	5.00	4.50	39.6	34.2	29.3	12.1	11.0	10.0
13	Pf kW	93.0	86.4	80.0	47.2	44.8	42.5	106	98.3	91.2	59.2	56.4	53.8
	Pa kW	26.7	28.8	31.3	14.6	15.3	16.1	29.9	32.4	35.4	19.0	20.0	21.2
	qw l/s	4.5	4.1	3.8	2.3	2.1	2.0	5.1	4.7	4.4	2.8	2.7	2.6
	dpw kPa	24.1	20.8	17.8	6.20	5.60	5.00	43.3	37.5	32.3	13.5	12.3	11.2
15	Pf kW	97.1	90.3	83.7	49.7	47.3	44.9	110	103	95.5	62.4	59.5	56.8
	Pa kW	27.3	29.5	32.0	14.8	15.5	16.3	30.7	33.2	36.2	19.3	20.4	21.6
	qw l/s	4.7	4.3	4.0	2.4	2.3	2.2	5.3	4.9	4.6	3.0	2.9	2.7
	dpw kPa	26.3	22.7	19.5	6.90	6.20	5.60	47.3	41.0	35.4	15.1	13.7	12.5

		100						110					
Twout	Tain	25	30	35	40	43	46	25	30	35	40	43	46
5	Pf kW	101	93.5	86.3	79.5	75.9	44.0	111	103	94.7	87.3	56.1	53.2
	Pa kW	30.4	33.0	36.1	39.8	42.4	20.0	34.7	37.6	41.1	45.2	23.6	24.9
	qw l/s	4.8	4.5	4.1	3.8	3.6	2.1	5.3	4.9	4.5	4.2	2.7	2.5
	dpw kPa	40.1	34.4	29.3	24.9	22.6	7.60	34.1	29.2	24.8	21.1	8.70	7.80
7	Pf kW	106	98.4	91.0	84.0	80.3	46.8	116	108	99.7	92.2	59.5	56.4
	Pa kW	31.1	33.7	36.8	40.6	43.2	20.2	35.4	38.4	42.0	46.1	23.9	25.2
	qw l/s	5.1	4.7	4.4	4.0	3.8	2.2	5.6	5.2	4.8	4.4	2.8	2.7
	dpw kPa	44.3	38.2	32.6	27.8	25.4	8.60	37.6	32.3	27.6	23.5	9.80	8.80
9	Pf kW	111	103	95.8	88.6	52.4	49.8	122	113	105	97.1	63.0	59.8
	Pa kW	31.7	34.4	37.6	41.4	19.4	20.5	36.2	39.3	42.8	47.1	24.2	25.5
	qw l/s	5.3	5.0	4.6	4.3	2.5	2.4	5.8	5.4	5.0	4.7	3.0	2.9
	dpw kPa	48.9	42.3	36.2	31.0	10.8	9.70	41.3	35.6	30.5	26.2	11.0	9.90
11	Pf kW	116	108	101	93.4	55.5	52.8	127	119	110	70.0	66.6	63.4
	Pa kW	32.5	35.2	38.4	42.3	19.6	20.7	37.0	40.1	43.8	23.3	24.5	25.8
	qw l/s	5.6	5.2	4.8	4.5	2.7	2.5	6.1	5.7	5.3	3.4	3.2	3.0
	dpw kPa	53.8	46.6	40.1	34.5	12.2	11.0	45.3	39.2	33.7	13.6	12.3	11.1
13	Pf kW	122	114	106	98.2	58.8	55.9	133	124	115	73.9	70.3	67.0
	Pa kW	33.2	36.0	39.2	43.2	19.9	21.0	37.9	41.0	44.7	23.7	24.9	26.2
	qw l/s	5.9	5.5	5.1	4.7	2.8	2.7	6.4	6.0	5.5	3.5	3.4	3.2
	dpw kPa	59.1	51.3	44.3	38.2	13.6	12.4	49.6	43.0	37.1	15.2	13.8	12.5
15	Pf kW	127	119	111	65.2	62.1	59.2	139	130	121	77.8	74.2	70.7
	Pa kW	34.0	36.8	40.1	19.2	20.2	21.3	38.8	42.0	45.7	24.0	25.2	26.5
	qw l/s	6.1	5.7	5.3	3.1	3.0	2.8	6.7	6.2	5.8	3.7	3.6	3.4
	dpw kPa	64.6	56.3	48.7	16.8	15.3	13.8	54.1	47.0	40.8	16.9	15.3	13.9

EWAQ~G-SR

		120						140						
Twout	Tain	25	30	35	40	43	46	25	30	35	40	43	46	
5	Pf	kW	121	112	103	95.5	57.6	54.6	145	134	124	114	73.3	69.4
	Pa	kW	38.3	41.6	45.4	49.7	22.7	24.0	44.8	48.6	53.0	58.0	30.9	32.7
	qw	l/s	5.8	5.4	4.9	4.6	2.8	2.6	6.9	6.4	5.9	5.4	3.5	3.3
	dpw	kPa	38.5	33.0	28.0	23.9	8.70	7.80	29.8	25.5	21.7	18.3	7.60	6.80
7	Pf	kW	127	118	109	64.4	61.1	58.0	152	141	130	120	77.8	73.8
	Pa	kW	39.2	42.5	46.3	21.9	23.0	24.3	45.7	49.6	54.0	59.1	31.3	33.1
	qw	l/s	6.1	5.6	5.2	3.1	2.9	2.8	7.3	6.8	6.2	5.8	3.7	3.5
	dpw	kPa	42.4	36.4	31.1	10.9	9.80	8.80	32.9	28.3	24.1	20.5	8.50	7.70
9	Pf	kW	133	123	114	68.1	64.7	61.4	160	148	137	127	82.4	78.2
	Pa	kW	40.0	43.4	47.3	22.2	23.3	24.6	46.7	50.6	55.1	60.3	31.8	33.5
	qw	l/s	6.4	5.9	5.5	3.3	3.1	2.9	7.7	7.1	6.6	6.1	3.9	3.7
	dpw	kPa	46.5	40.0	34.3	12.2	11.0	9.90	36.3	31.2	26.7	22.8	9.60	8.70
11	Pf	kW	139	129	120	71.9	68.4	65.1	167	155	144	133	87.2	82.8
	Pa	kW	41.0	44.4	48.3	22.5	23.6	24.9	47.8	51.7	56.2	61.5	32.2	34.0
	qw	l/s	6.7	6.2	5.7	3.4	3.3	3.1	8.0	7.5	6.9	6.4	4.2	4.0
	dpw	kPa	50.8	43.9	37.8	13.6	12.3	11.1	39.8	34.3	29.4	25.2	10.8	9.70
13	Pf	kW	145	135	125	75.9	72.2	68.8	175	163	151	96.8	92.1	87.6
	Pa	kW	41.9	45.4	49.3	22.8	24.0	25.2	48.9	52.8	57.4	31.1	32.7	34.5
	qw	l/s	7.0	6.5	6.0	3.6	3.5	3.3	8.4	7.8	7.2	4.6	4.4	4.2
	dpw	kPa	55.4	48.0	41.5	15.2	13.8	12.5	43.6	37.7	32.4	13.3	12.0	10.9
15	Pf	kW	151	141	86.4	79.9	76.2	72.6	183	170	158	102	97.2	92.5
	Pa	kW	42.9	46.4	21.4	23.1	24.3	25.6	50.0	54.1	58.7	31.6	33.3	35.1
	qw	l/s	7.3	6.8	4.1	3.8	3.7	3.5	8.8	8.2	7.6	4.9	4.7	4.4
	dpw	kPa	60.3	52.5	19.7	16.9	15.3	13.9	47.6	41.3	35.6	14.8	13.4	12.2

		155						
Twout	Tain	25	30	35	40	43	46	
5	Pf	kW	160	148	136	126	75.0	71.0
	Pa	kW	50.4	54.8	59.9	66.0	30.0	31.7
	qw	l/s	7.7	7.1	6.5	6.0	3.6	3.4
	dpw	kPa	27.6	23.6	20.0	17.0	6.00	5.40
7	Pf	kW	168	155	143	83.9	79.5	75.4
	Pa	kW	51.6	56.0	61.2	28.9	30.4	32.1
	qw	l/s	8.0	7.4	6.9	4.0	3.8	3.6
	dpw	kPa	30.4	26.1	22.2	7.60	6.80	6.10
9	Pf	kW	176	163	151	88.8	84.3	80.0
	Pa	kW	52.8	57.3	62.6	29.3	30.9	32.6
	qw	l/s	8.4	7.8	7.2	4.2	4.0	3.8
	dpw	kPa	33.4	28.7	24.5	8.50	7.70	6.90
11	Pf	kW	184	171	158	93.9	89.2	84.7
	Pa	kW	54.1	58.7	64.0	29.8	31.3	33.0
	qw	l/s	8.8	8.2	7.6	4.5	4.3	4.1
	dpw	kPa	36.6	31.5	27.1	9.50	8.60	7.80
13	Pf	kW	192	178	166	99.1	94.2	89.6
	Pa	kW	55.5	60.2	65.6	30.2	31.8	33.5
	qw	l/s	9.2	8.6	7.9	4.7	4.5	4.3
	dpw	kPa	40.0	34.6	29.8	10.6	9.60	8.70
15	Pf	kW	200	186	173	104	99.4	94.6
	Pa	kW	56.9	61.7	67.3	30.8	32.4	34.1
	qw	l/s	9.6	9.0	8.3	5.0	4.8	4.5
	dpw	kPa	43.6	37.8	32.6	11.8	10.7	9.70

EWAQ~G-XS

		080						090					
Twout	Tain	25	30	35	40	43	46	25	30	35	40	43	46
5	Pf kW	87.3	81.6	75.6	69.5	65.8	62.3	98.8	92.3	85.5	78.6	74.6	70.7
	Pa kW	21.8	23.5	25.4	27.6	29.0	30.6	24.5	26.4	28.6	31.2	32.9	34.9
	qw l/s	4.2	3.9	3.6	3.3	3.1	3.0	4.7	4.4	4.1	3.8	3.6	3.4
	dpw kPa	30.7	26.9	23.1	19.5	17.5	15.6	39.1	34.1	29.2	24.7	22.2	20.0
7	Pf kW	92.0	86.1	79.8	73.4	69.7	66.0	104	97.4	90.3	83.1	79.0	75.0
	Pa kW	22.1	23.8	25.8	27.9	29.4	31.0	24.9	26.8	29.0	31.6	33.4	35.3
	qw l/s	4.4	4.1	3.8	3.5	3.3	3.2	5.0	4.7	4.3	4.0	3.8	3.6
	dpw kPa	34.2	30.0	25.7	21.8	19.6	17.6	43.6	38.0	32.7	27.7	25.0	22.5
9	Pf kW	96.9	90.6	84.1	77.5	73.6	69.8	110	103	95.2	87.8	83.5	79.5
	Pa kW	22.5	24.2	26.1	28.3	29.8	31.4	25.3	27.3	29.5	32.1	33.9	35.8
	qw l/s	4.6	4.3	4.0	3.7	3.5	3.3	5.3	4.9	4.6	4.2	4.0	3.8
	dpw kPa	38.1	33.3	28.7	24.3	21.9	19.7	48.4	42.3	36.4	31.0	28.0	25.3
11	Pf kW	102	95.3	88.5	81.7	77.7	73.8	115	108	100	92.6	88.2	84.0
	Pa kW	22.8	24.6	26.5	28.7	30.1	31.7	25.8	27.7	30.0	32.6	34.3	36.3
	qw l/s	4.9	4.6	4.3	3.9	3.7	3.5	5.5	5.2	4.8	4.4	4.2	4.0
	dpw kPa	42.2	36.9	31.8	27.1	24.5	22.1	53.6	46.9	40.4	34.5	31.3	28.4
13	Pf kW	107	100	93.1	86.0	81.9	77.8	121	113	105	97.6	93.0	88.7
	Pa kW	23.2	25.0	26.9	29.1	30.5	32.1	26.2	28.2	30.5	33.1	34.9	36.8
	qw l/s	5.1	4.8	4.5	4.1	3.9	3.7	5.8	5.5	5.1	4.7	4.5	4.3
	dpw kPa	46.6	40.8	35.3	30.1	27.2	24.6	59.2	51.9	44.8	38.4	34.9	31.7
15	Pf kW	112	105	97.8	90.5	86.2	82.0	127	119	111	103	98.0	93.5
	Pa kW	23.6	25.4	27.3	29.5	31.0	32.6	26.7	28.7	31.0	33.6	35.4	37.4
	qw l/s	5.4	5.1	4.7	4.4	4.1	3.9	6.1	5.7	5.3	4.9	4.7	4.5
	dpw kPa	51.4	45.1	39.0	33.3	30.2	27.4	65.2	57.2	49.6	42.6	38.7	35.3

		105						115					
Twout	Tain	25	30	35	40	43	46	25	30	35	40	43	46
5	Pf kW	115	108	99.5	91.5	86.8	82.4	128	120	110	101	96.2	91.3
	Pa kW	28.5	30.7	33.3	36.3	38.3	40.6	31.7	34.3	37.1	40.5	42.7	45.2
	qw l/s	5.5	5.1	4.8	4.4	4.1	3.9	6.1	5.7	5.3	4.8	4.6	4.4
	dpw kPa	24.4	21.2	18.1	15.3	13.8	12.4	24.0	20.8	17.7	14.9	13.4	12.1
7	Pf kW	122	114	105	97.0	92.1	87.6	135	126	117	107	102	97.0
	Pa kW	29.0	31.2	33.8	36.8	38.9	41.2	32.3	34.8	37.7	41.0	43.3	45.8
	qw l/s	5.8	5.4	5.0	4.6	4.4	4.2	6.5	6.0	5.6	5.1	4.9	4.6
	dpw kPa	27.2	23.7	20.3	17.2	15.5	14.0	26.7	23.2	19.9	16.8	15.1	13.7
9	Pf kW	129	120	111	103	97.6	92.9	143	133	123	114	108	103
	Pa kW	29.5	31.7	34.3	37.3	39.4	41.7	32.8	35.4	38.3	41.6	43.9	46.4
	qw l/s	6.2	5.8	5.3	4.9	4.7	4.4	6.8	6.4	5.9	5.4	5.2	4.9
	dpw kPa	30.4	26.5	22.7	19.3	17.5	15.8	29.7	25.8	22.2	18.8	17.0	15.4
11	Pf kW	135	126	117	108	103	98.4	150	140	130	120	114	109
	Pa kW	30.0	32.2	34.8	37.9	40.0	42.3	33.4	36.0	38.9	42.3	44.6	47.1
	qw l/s	6.5	6.1	5.6	5.2	5.0	4.7	7.2	6.7	6.2	5.7	5.5	5.2
	dpw kPa	33.7	29.4	25.3	21.6	19.6	17.8	32.9	28.7	24.7	21.0	19.0	17.3
13	Pf kW	142	133	124	114	109	104	158	147	137	126	120	115
	Pa kW	30.5	32.8	35.4	38.5	40.6	43.0	34.0	36.6	39.5	42.9	45.2	47.8
	qw l/s	6.8	6.4	5.9	5.5	5.2	5.0	7.6	7.1	6.6	6.1	5.8	5.5
	dpw kPa	37.3	32.7	28.2	24.1	21.9	19.9	36.4	31.7	27.4	23.4	21.2	19.3
15	Pf kW	149	140	130	121	115	110	165	155	144	133	127	121
	Pa kW	31.1	33.3	36.0	39.1	41.2	43.6	34.6	37.2	40.2	43.6	46.0	48.5
	qw l/s	7.2	6.7	6.3	5.8	5.5	5.3	7.9	7.4	6.9	6.4	6.1	5.8
	dpw kPa	41.2	36.1	31.3	26.8	24.4	22.3	40.1	35.0	30.3	26.0	23.6	21.5

EWAQ~G-XS

Twout	Tain	130						150						
		25	30	35	40	43	46	25	30	35	40	43	46	
5	Pf	kW	143	134	124	114	108	102	164	153	141	129	123	116
	Pa	kW	35.7	38.5	41.7	45.3	47.7	50.3	40.4	43.7	47.4	51.6	54.4	57.5
	qw	l/s	6.9	6.4	5.9	5.4	5.2	4.9	7.8	7.3	6.7	6.2	5.9	5.6
	dpw	kPa	30.3	26.5	22.7	19.1	17.2	15.4	24.9	21.6	18.4	15.5	13.9	12.5
7	Pf	kW	151	141	131	121	114	109	173	161	149	137	130	124
	Pa	kW	36.2	39.1	42.3	45.9	48.3	50.9	41.1	44.4	48.1	52.3	55.2	58.3
	qw	l/s	7.2	6.8	6.3	5.8	5.5	5.2	8.3	7.7	7.1	6.6	6.2	5.9
	dpw	kPa	33.8	29.6	25.4	21.5	19.4	17.4	27.8	24.1	20.6	17.4	15.7	14.1
9	Pf	kW	159	149	138	127	121	115	182	170	157	145	138	131
	Pa	kW	36.8	39.6	42.8	46.5	48.9	51.5	41.8	45.1	48.8	53.1	55.9	59.1
	qw	l/s	7.6	7.1	6.6	6.1	5.8	5.5	8.7	8.1	7.5	6.9	6.6	6.3
	dpw	kPa	37.6	32.9	28.3	24.0	21.7	19.6	30.8	26.8	23.0	19.5	17.6	15.9
11	Pf	kW	167	157	146	135	128	122	191	179	166	153	145	138
	Pa	kW	37.4	40.2	43.4	47.1	49.5	52.1	42.6	45.9	49.6	53.9	56.8	59.9
	qw	l/s	8.0	7.5	7.0	6.5	6.1	5.8	9.2	8.6	7.9	7.3	7.0	6.6
	dpw	kPa	41.7	36.5	31.5	26.8	24.3	22.0	34.2	29.7	25.5	21.7	19.7	17.8
13	Pf	kW	176	165	153	142	135	129	201	188	174	161	153	146
	Pa	kW	38.0	40.8	44.0	47.7	50.1	52.8	43.4	46.7	50.5	54.8	57.6	60.8
	qw	l/s	8.5	7.9	7.4	6.8	6.5	6.2	9.7	9.0	8.4	7.7	7.4	7.0
	dpw	kPa	46.1	40.4	34.9	29.9	27.1	24.6	37.7	32.9	28.3	24.1	21.9	19.9
15	Pf	kW	185	173	161	149	142	136	211	197	183	169	162	154
	Pa	kW	38.6	41.5	44.7	48.4	50.8	53.5	44.2	47.5	51.3	55.7	58.6	61.7
	qw	l/s	8.9	8.3	7.7	7.2	6.8	6.5	10	9.5	8.8	8.1	7.8	7.4
	dpw	kPa	50.8	44.6	38.7	33.2	30.2	27.4	41.5	36.3	31.3	26.8	24.4	22.2

EWAQ~G-XR

		080						090					
Twout	Tain	25	30	35	40	43	46	25	30	35	40	43	46
5	Pf kW	83.8	78.0	72.1	66.1	62.6	59.2	94.9	88.3	81.6	74.9	71.1	67.6
	Pa kW	22.2	24.0	26.0	28.3	29.9	31.6	25.0	27.1	29.4	32.2	34.1	36.2
	qw l/s	4.0	3.7	3.4	3.2	3.0	2.8	4.5	4.2	3.9	3.6	3.4	3.2
	dpw kPa	28.3	24.6	20.9	17.6	15.8	14.1	36.0	31.2	26.6	22.4	20.2	18.2
7	Pf kW	88.1	82.1	76.0	69.8	66.2	62.7	99.8	93.0	86.0	79.2	75.3	71.6
	Pa kW	22.6	24.4	26.4	28.7	30.3	32.0	25.5	27.5	29.9	32.7	34.6	36.7
	qw l/s	4.2	3.9	3.6	3.3	3.2	3.0	4.8	4.5	4.1	3.8	3.6	3.4
	dpw kPa	31.4	27.3	23.3	19.7	17.7	15.9	40.0	34.7	29.6	25.1	22.7	20.5
9	Pf kW	92.6	86.3	79.9	73.6	69.9	66.3	105	97.8	90.6	83.5	79.5	75.8
	Pa kW	23.0	24.8	26.8	29.2	30.7	32.5	26.0	28.0	30.4	33.2	35.1	37.3
	qw l/s	4.4	4.1	3.8	3.5	3.3	3.2	5.0	4.7	4.3	4.0	3.8	3.6
	dpw kPa	34.8	30.2	25.9	21.9	19.7	17.8	44.3	38.4	32.9	28.0	25.4	23.0
11	Pf kW	97.2	90.7	84.0	77.4	73.6	70.0	110	103	95.3	88.0	83.9	80.3
	Pa kW	23.4	25.3	27.3	29.6	31.2	32.9	26.5	28.6	31.0	33.8	35.7	37.8
	qw l/s	4.7	4.4	4.0	3.7	3.5	3.4	5.3	4.9	4.6	4.2	4.0	3.8
	dpw kPa	38.4	33.4	28.6	24.3	22.0	19.8	48.9	42.5	36.5	31.2	28.3	25.4
13	Pf kW	102	95.1	88.2	81.4	77.5	74.5	115	108	100	92.6	88.4	85.5
	Pa kW	23.9	25.7	27.7	30.1	31.7	33.5	27.0	29.1	31.5	34.4	36.3	38.3
	qw l/s	4.9	4.6	4.2	3.9	3.7	3.5	5.6	5.2	4.8	4.5	4.2	4.0
	dpw kPa	42.3	36.8	31.6	26.9	24.4	22.0	53.8	46.8	40.4	34.6	31.4	28.8
15	Pf kW	107	99.7	92.5	85.6	81.5	78.1	121	113	105	97.3	93.0	89.7
	Pa kW	24.3	26.2	28.2	30.6	32.1	33.7	27.6	29.7	32.2	35.0	37.0	39.1
	qw l/s	5.1	4.8	4.5	4.1	3.9	3.7	5.8	5.4	5.1	4.7	4.5	4.3
	dpw kPa	46.4	40.5	34.9	29.8	27.0	24.5	59.1	51.5	44.5	38.2	34.9	31.8

		105						115					
Twout	Tain	25	30	35	40	43	46	25	30	35	40	43	46
5	Pf kW	111	103	94.9	87.2	82.8	78.8	122	114	105	96.1	91.3	86.9
	Pa kW	29.0	31.3	34.1	37.3	39.6	42.1	32.6	35.3	38.4	41.9	44.4	47.1
	qw l/s	5.3	4.9	4.5	4.2	4.0	3.8	5.9	5.4	5.0	4.6	4.4	4.2
	dpw kPa	22.4	19.3	16.5	13.9	12.5	11.3	21.8	18.7	15.9	13.4	12.1	11.0
7	Pf kW	117	109	100	92.3	87.8	83.7	129	120	110	102	96.7	92.6
	Pa kW	29.5	31.9	34.7	37.9	40.2	42.7	33.2	35.9	39.0	42.6	45.1	47.6
	qw l/s	5.6	5.2	4.8	4.4	4.2	4.0	6.2	5.7	5.3	4.9	4.6	4.3
	dpw kPa	25.0	21.6	18.4	15.6	14.1	12.8	24.2	20.9	17.8	15.0	13.6	12.2
9	Pf kW	123	114	106	97.6	93.0	88.7	135	126	116	107	102	98.4
	Pa kW	30.1	32.5	35.3	38.6	40.9	43.4	33.9	36.6	39.7	43.4	45.9	48.4
	qw l/s	5.9	5.5	5.1	4.7	4.5	4.2	6.5	6.0	5.6	5.1	4.9	4.6
	dpw kPa	27.7	24.0	20.6	17.5	15.8	14.4	26.8	23.1	19.8	16.8	15.2	13.8
11	Pf kW	129	120	112	103	98.3	93.8	142	132	123	113	108	103.3
	Pa kW	30.7	33.1	35.9	39.3	41.6	44.2	34.5	37.3	40.5	44.1	46.6	49.1
	qw l/s	6.2	5.8	5.3	4.9	4.7	4.5	6.8	6.3	5.9	5.4	5.2	4.9
	dpw kPa	30.7	26.6	22.9	19.5	17.7	16.2	29.6	25.6	21.9	18.7	17.0	15.4
13	Pf kW	135	126	117	109	103	99.2	149	139	129	119	114	109.3
	Pa kW	31.3	33.8	36.6	40.0	42.3	44.7	35.2	38.0	41.2	44.9	47.5	50.1
	qw l/s	6.5	6.1	5.6	5.2	5.0	4.8	7.2	6.7	6.2	5.7	5.5	5.2
	dpw kPa	33.8	29.4	25.3	21.7	19.8	18.0	32.6	28.3	24.3	20.8	19.0	17.2
15	Pf kW	142	133	123	114	109	104.7	156	146	135	125	119.4	114.7
	Pa kW	32.0	34.4	37.3	40.7	43.1	45.5	36.0	38.8	42.0	45.8	48.4	51.1
	qw l/s	6.8	6.4	5.9	5.5	5.2	5.0	7.5	7.0	6.5	6.0	5.8	5.5
	dpw kPa	37.2	32.5	28.0	24.1	22.0	20.0	35.8	31.1	26.8	23.0	21.0	19.0

EWAQ~G-XR

Twout	Tain	130						150						
		25	30	35	40	43	46	25	30	35	40	43	46	
5	Pf	kW	138	128	118	109	103	98.0	156	145	134	122	116	111
	Pa	kW	36.3	39.3	42.7	46.5	49.0	51.8	41.6	45.1	49.0	53.5	56.5	59.9
	qw	l/s	6.6	6.1	5.7	5.2	4.9	4.7	7.5	6.9	6.4	5.9	5.6	5.3
	dpw	kPa	28.0	24.2	20.6	17.4	15.6	14.1	22.6	19.4	16.5	13.9	12.5	11.3
7	Pf	kW	145	135	125	115	109	104	164	153	141	129	123	77.0
	Pa	kW	37.0	40.0	43.3	47.1	49.7	52.5	42.4	45.9	49.8	54.4	57.4	31.6
	qw	l/s	6.9	6.5	6.0	5.5	5.2	5.0	7.9	7.3	6.7	6.2	5.9	3.7
	dpw	kPa	31.1	26.9	23.0	19.4	17.5	15.9	25.1	21.6	18.4	15.5	14.0	5.50
9	Pf	kW	152	142	131	121	115	110	173	161	148	137	130	81.8
	Pa	kW	37.6	40.6	44.0	47.8	50.4	53.2	43.3	46.8	50.7	55.3	58.4	32.0
	qw	l/s	7.3	6.8	6.3	5.8	5.5	5.3	8.3	7.7	7.1	6.5	6.2	3.9
	dpw	kPa	34.4	29.9	25.6	21.7	19.7	17.8	27.7	23.9	20.4	17.3	15.7	6.20
11	Pf	kW	160	149	138	128	122	116	181	169	156	144	137	86.8
	Pa	kW	38.3	41.3	44.7	48.6	51.2	54.0	44.1	47.7	51.7	56.3	59.4	32.4
	qw	l/s	7.7	7.2	6.6	6.1	5.8	5.6	8.7	8.1	7.5	6.9	6.6	4.2
	dpw	kPa	38.0	33.1	28.4	24.2	21.9	19.9	30.6	26.5	22.7	19.3	17.5	7.00
13	Pf	kW	168	157	145	135	128	73.5	190	177	164	152	145	91.9
	Pa	kW	39.0	42.0	45.4	49.3	51.9	25.6	45.1	48.6	52.7	57.3	60.5	32.8
	qw	l/s	8.1	7.5	7.0	6.5	6.2	3.5	9.1	8.5	7.9	7.3	6.9	4.4
	dpw	kPa	41.9	36.5	31.4	26.9	24.4	8.00	33.7	29.2	25.1	21.4	19.5	7.90
15	Pf	kW	176	164	153	141	135	77.9	199	185	172	159	102	97.2
	Pa	kW	39.7	42.8	46.2	50.1	52.7	25.8	46.0	49.6	53.7	58.4	31.6	33.3
	qw	l/s	8.5	7.9	7.3	6.8	6.5	3.7	9.6	8.9	8.3	7.6	4.9	4.7
	dpw	kPa	46.1	40.2	34.7	29.8	27.1	9.00	36.9	32.1	27.6	23.7	9.70	8.80

Water Pump Kit for EWAQ~G SS/SR (standard efficiency version)

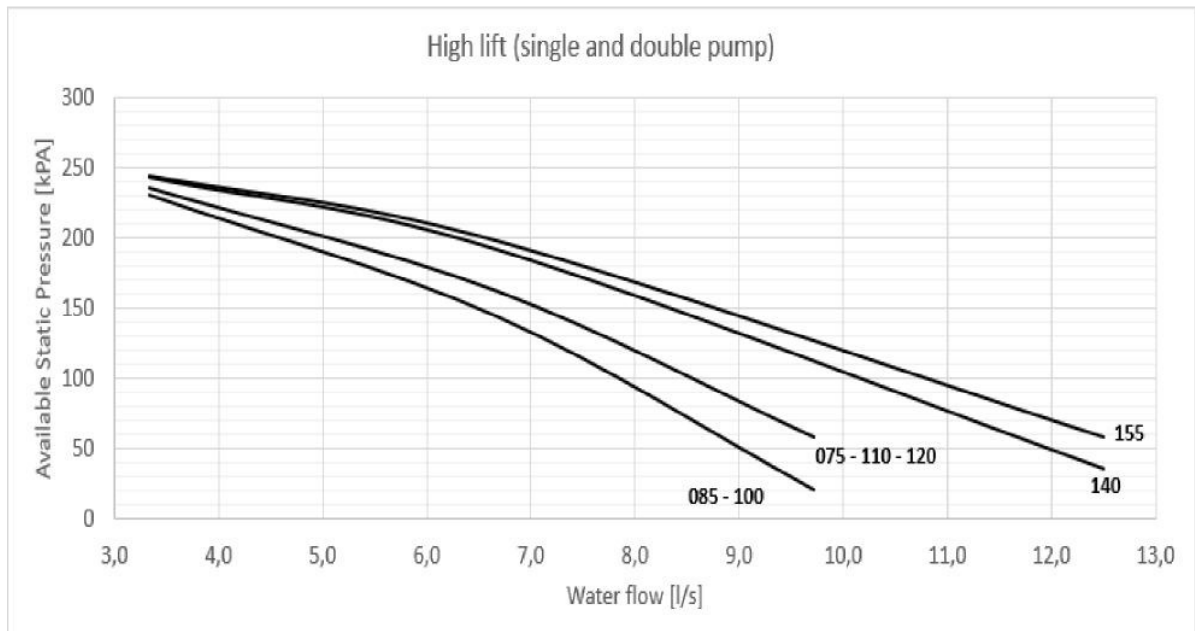
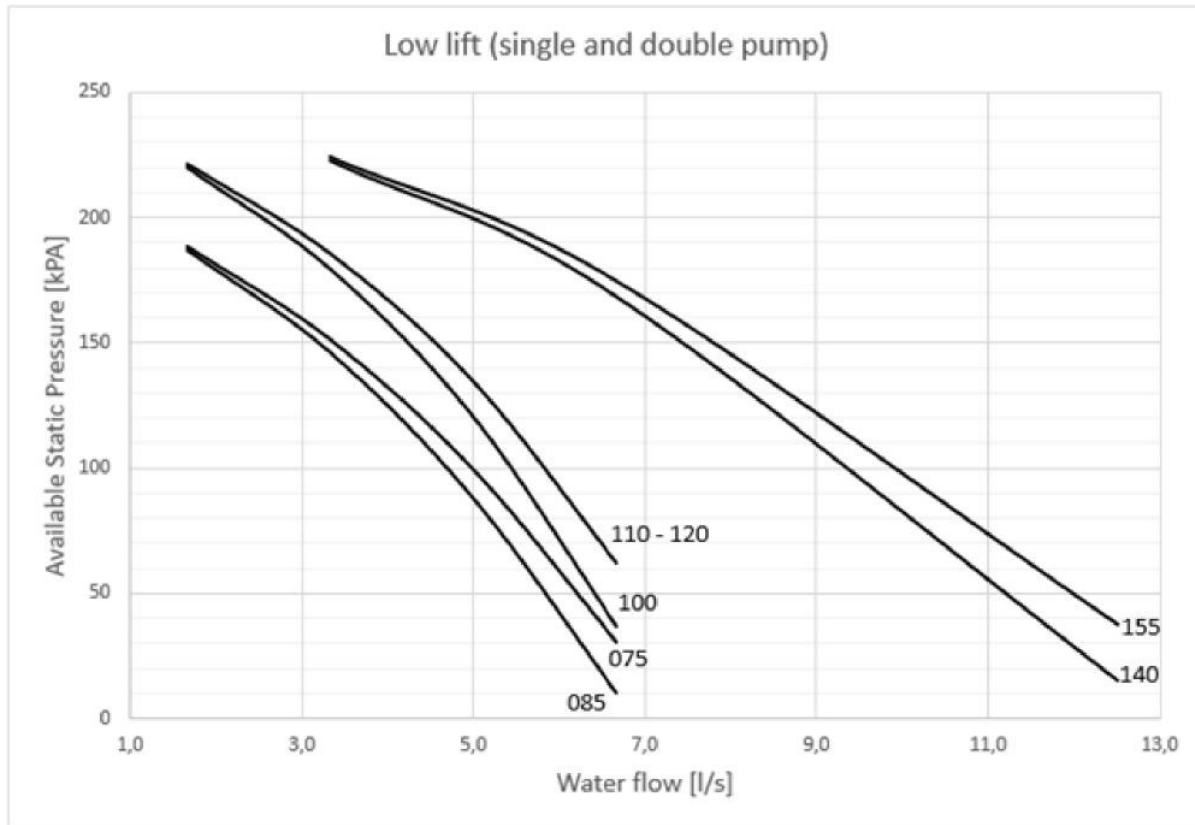

The above curves are representing the available static pressure external to the unit using pure water. The pressure drops of the water filter (available as option) are not included.

Standard pumps are suitable to be used with pure water or ethylene glycol up to 30%. If using ethylene glycol above 30% or propylene glycol please contact factory.

Water Pump Kit for EWAQ~G XS/XR (high efficiency version)

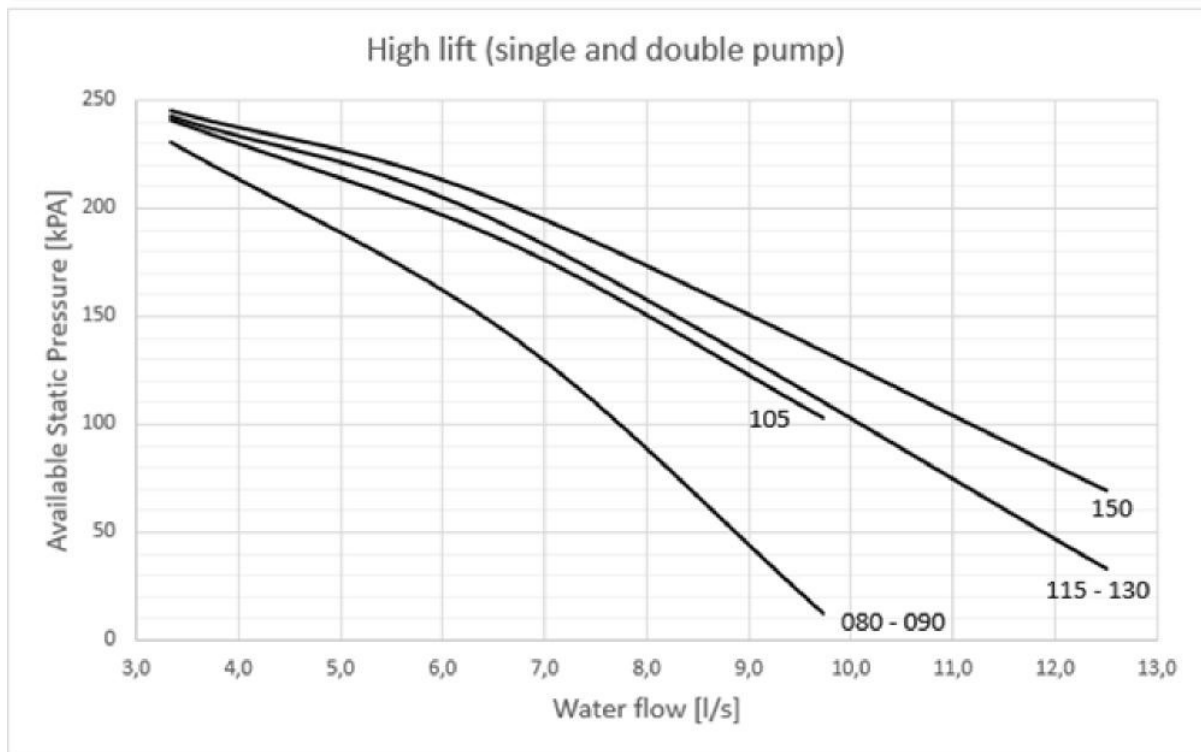
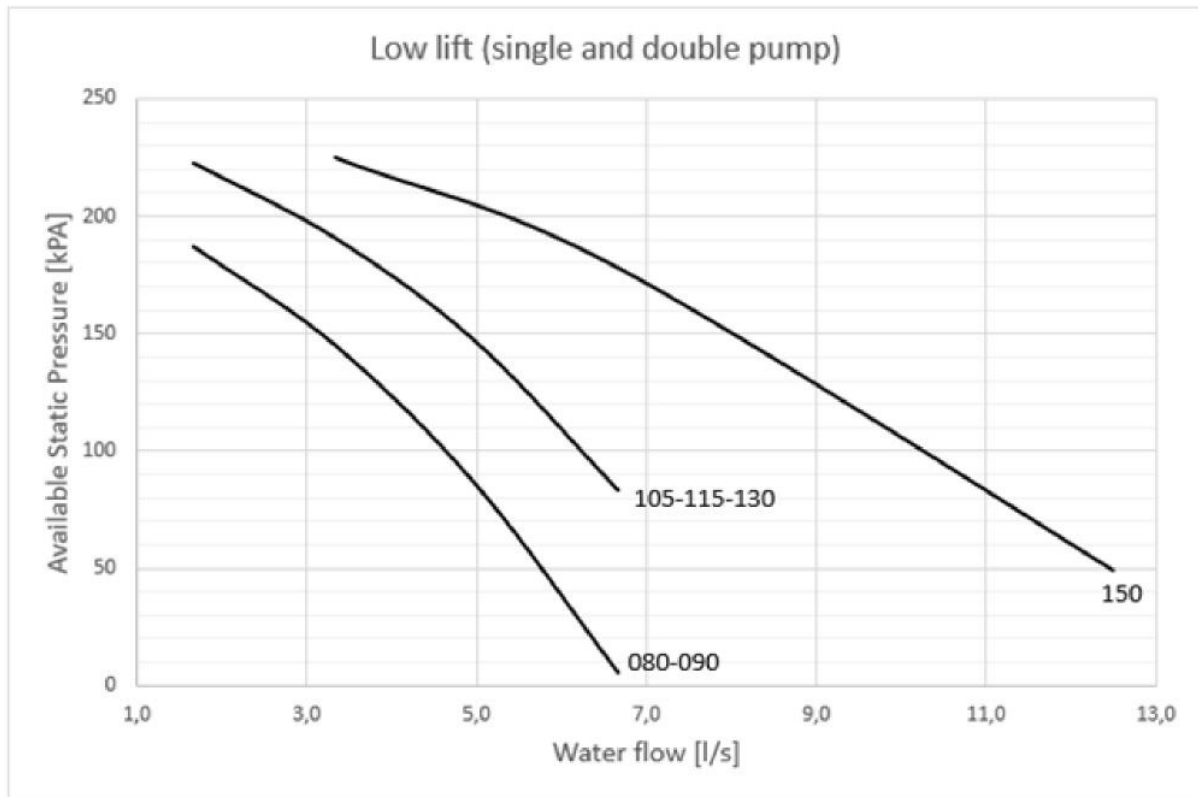

The above curves are representing the available static pressure external to the unit using pure water. The pressure drops of the water filter (available as option) are not included.

Standard pumps are suitable to be used with pure water or ethylene glycol up to 30%. If using ethylene glycol above 30% or propylene glycol please contact factory.

Water Pump Kit - Technical Information

EWAQ~G SS/SR (standard efficiency version)

Model		Pump Motor Power [kW]	Pump Motor Current [A]	Power supply [V-ph-Hz]	PN	Motor Protection	Insulation (Class)	Working temperature [°C]
Low lift	EWAQ075G-SS / EWAQ075G-SR	1,1	3,3	400-3-50	8	IP55	F	-15/90
	EWAQ085G-SS / EWAQ085G-SR	1,1	3,3	400-3-50	8	IP55	F	-15/90
	EWAQ100G-SS / EWAQ100G-SR	1,5	3,8	400-3-50	8	IP55	F	-15/90
	EWAQ110G-SS / EWAQ110G-SR	1,5	3,8	400-3-50	8	IP55	F	-15/90
	EWAQ120G-SS / EWAQ120G-SR	1,5	3,8	400-3-50	8	IP55	F	-15/90
	EWAQ140G-SS / EWAQ140G-SR	2,2	4,5	400-3-50	8	IP55	F	-15/90
High lift	EWAQ155G-SS / EWAQ155G-SR	2,2	4,5	400-3-50	8	IP55	F	-15/90
	EWAQ075G-SS / EWAQ075G-SR	3	6,4	400-3-50	8	IP55	F	-15/90
	EWAQ085G-SS / EWAQ085G-SR	3	6,4	400-3-50	8	IP55	F	-15/90
	EWAQ100G-SS / EWAQ100G-SR	3	6,4	400-3-50	8	IP55	F	-15/90
	EWAQ110G-SS / EWAQ110G-SR	3	6,4	400-3-50	8	IP55	F	-15/90
	EWAQ120G-SS / EWAQ120G-SR	3	6,4	400-3-50	8	IP55	F	-15/90
	EWAQ140G-SS / EWAQ140G-SR	3	6,4	400-3-50	8	IP55	F	-15/90
	EWAQ155G-SS / EWAQ155G-SR	3	6,4	400-3-50	8	IP55	F	-15/90

EWAQ~G XS/XR (high efficiency version)

Model		Pump Motor Power [kW]	Pump Motor Current [A]	Power supply [V-ph-Hz]	PN	Motor Protection	Insulation (Class)	Working temperature [°C]
Low lift	EWAQ080G-XS / EWAQ080G-XR	1,1	3,3	400-3-50	8	IP55	F	-15/90
	EWAQ090G-XS / EWAQ090G-XR	1,1	3,3	400-3-50	8	IP55	F	-15/90
	EWAQ105G-XS / EWAQ105G-XR	1,5	3,8	400-3-50	8	IP55	F	-15/90
	EWAQ115G-XS / EWAQ115G-XR	1,5	3,8	400-3-50	8	IP55	F	-15/90
	EWAQ130G-XS / EWAQ130G-XR	1,5	3,8	400-3-50	8	IP55	F	-15/90
	EWAQ150G-XS / EWAQ150G-XR	2,2	4,5	400-3-50	8	IP55	F	-15/90
High lift	EWAQ080G-XS / EWAQ080G-XR	3	6,4	400-3-50	8	IP55	F	-15/90
	EWAQ090G-XS / EWAQ090G-XR	3	6,4	400-3-50	8	IP55	F	-15/90
	EWAQ105G-XS / EWAQ105G-XR	3	6,4	400-3-50	8	IP55	F	-15/90
	EWAQ115G-XS / EWAQ115G-XR	3	6,4	400-3-50	8	IP55	F	-15/90
	EWAQ130G-XS / EWAQ130G-XR	3	6,4	400-3-50	8	IP55	F	-15/90
	EWAQ150G-XS / EWAQ150G-XR	3	6,4	400-3-50	8	IP55	F	-15/90

Filter pressure drops (size 2' 2/12)

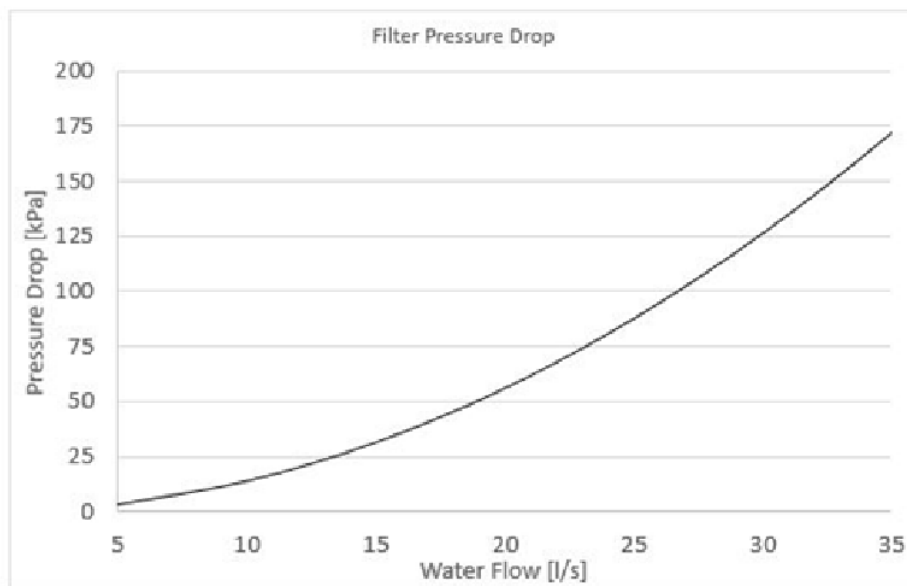

Note:
to calculate the pressure drops values introduced by the water filter, refer to the above curve.

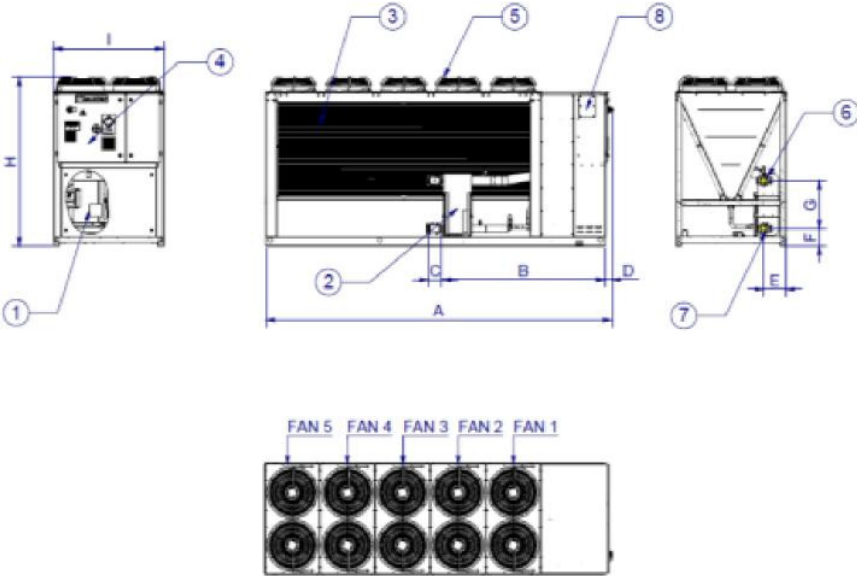

LEGEND

- 1. COMPRESSOR
- 2. EVAPORATOR
- 3. CONDENSER COIL
- 4. ELECTRICAL PANEL
- 5. FAN
- 6. EVAPORATOR WATER INLET
- 7. EVAPORATOR WATER OUTLET
- 8. SLOT FOR POWER AND CONTROL PANEL CONNECTION

MODEL	A	B	C	D	E	F	G	H	I
EWAQ075G-SS	2140	1657	152	74	238	189	519	1800	1195
EWAQ085G-SS	2680	1641	152	74	238	189	519	1800	1195
EWAQ100G-SS	2680	1641	152	74	238	189	519	1800	1195
EWAQ110G-SS	2680	1657	152	74	238	189	519	1800	1195
EWAQ120G-SS	3200	1657	152	74	238	189	519	1800	1195
EWAQ140G-SS	3200	1714	152	74	238	189	519	1800	1195
EWAQ155G-SS	3200	1743	152	74	238	189	519	1800	1195

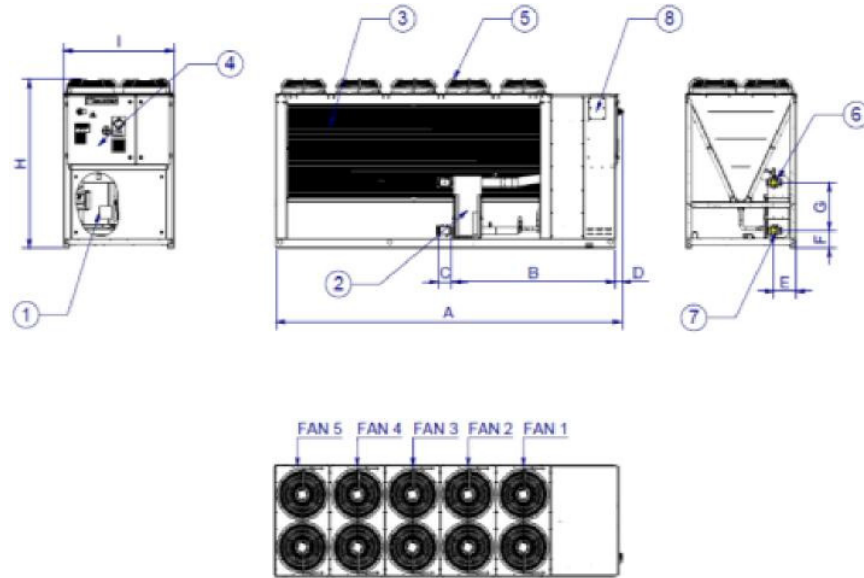

LEGEND

- 1. COMPRESSOR
- 2. EVAPORATOR
- 3. CONDENSER COIL
- 4. ELECTRICAL PANEL
- 5. FAN
- 6. EVAPORATOR WATER INLET
- 7. EVAPORATOR WATER OUTLET
- 8. SLOT FOR POWER AND CONTROL PANEL CONNECTION

MODEL	A	B	C	D	E	F	G	H	I
EWAQ075G-SR	2140	1657	152	74	238	189	519	1800	1195
EWAQ085G-SR	2680	1641	152	74	238	189	519	1800	1195
EWAQ100G-SR	2680	1641	152	74	238	189	519	1800	1195
EWAQ110G-SR	2680	1657	152	74	238	189	519	1800	1195
EWAQ120G-SR	3200	1657	152	74	238	189	519	1800	1195
EWAQ140G-SR	3200	1714	152	74	238	189	519	1800	1195
EWAQ155G-SR	3200	1743	152	74	238	189	519	1800	1195

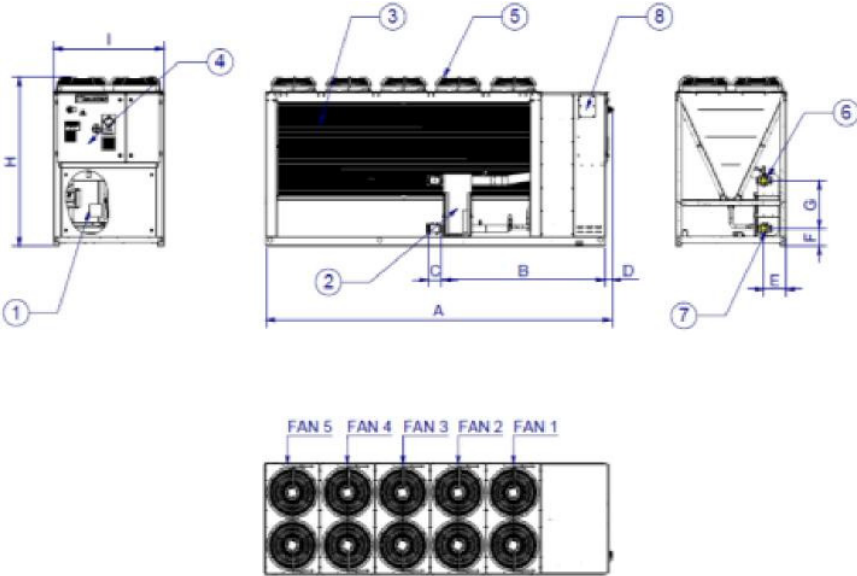

LEGEND

- 1. COMPRESSOR
- 2. EVAPORATOR
- 3. CONDENSER COIL
- 4. ELECTRICAL PANEL
- 5. FAN
- 6. EVAPORATOR WATER INLET
- 7. EVAPORATOR WATER OUTLET
- 8. SLOT FOR POWER AND CONTROL PANEL CONNECTION

MODEL	A	B	C	D	E	F	G	H	I
EWAQ080G-XS	2680	1641	152	74	238	189	519	1800	1195
EWAQ090G-XS	3200	1641	152	74	238	189	519	1800	1195
EWAQ105G-XS	3200	1693	152	74	238	189	519	1800	1195
EWAQ115G-XS	3200	1714	152	74	238	189	519	1800	1195
EWAQ130G-XS	3800	1714	152	74	238	189	519	1820	1195
EWAQ150G-XS	3800	1776	152	74	238	189	519	1820	1195

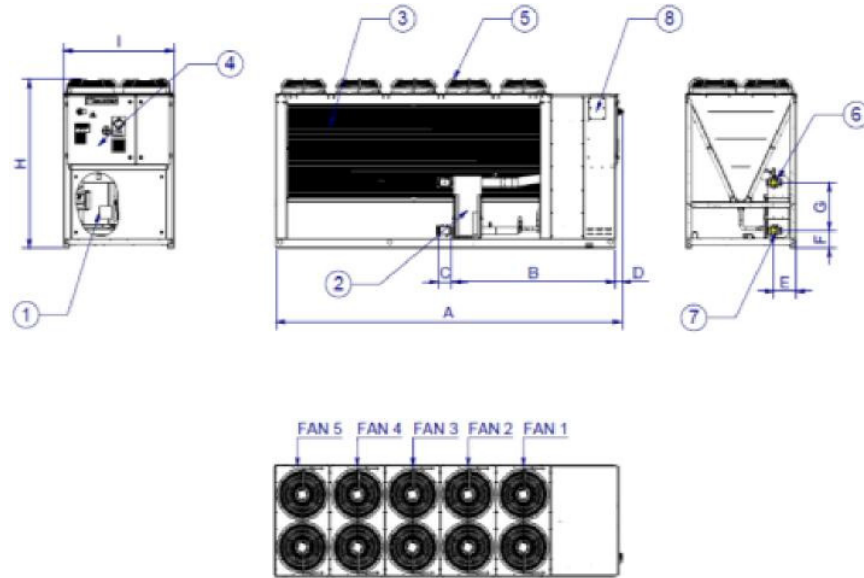

LEGEND

- 1. COMPRESSOR
- 2. EVAPORATOR
- 3. CONDENSER COIL
- 4. ELECTRICAL PANEL
- 5. FAN
- 6. EVAPORATOR WATER INLET
- 7. EVAPORATOR WATER OUTLET
- 8. SLOT FOR POWER AND CONTROL PANEL CONNECTION

MODEL	A	B	C	D	E	F	G	H	I
EWAQ080G-XR	2680	1641	152	74	238	189	519	1800	1195
EWAQ090G-XR	3200	1641	152	74	238	189	519	1800	1195
EWAQ105G-XR	3200	1693	152	74	238	189	519	1800	1195
EWAQ115G-XR	3200	1714	152	74	238	189	519	1800	1195
EWAQ130G-XR	3800	1714	152	74	238	189	519	1820	1195
EWAQ150G-XR	3800	1776	152	74	238	189	519	1820	1195

Warning Installation and maintenance of the unit must be performed only by qualified personnel who have knowledge with local codes and regulations and experience with this type of equipment. Must be avoided the unit installation in places that could be considered dangerous for all the maintenance operations.

Handling Care should be taken to avoid rough handling or shock due to dropping the unit. Do not push or pull the unit from anything other than the base frame. Never allow the unit to fall during unloading or moving as this may result in serious damage. To lift the unit, rings are provided in the base frame of the unit. Spreader bar and cables should be arranged to prevent damage to the condenser coil or unit cabinet.

Location The units are produced for outdoor installation on roofs, floors or below ground level on condition that the area is free from obstacles for the passage of the condenser air. The unit should be positioned on solid foundations and perfectly leveled; in the case of installation on roofs or floors, it may be advisable to arrange the use of suitable weight distribution beams. When the units are installed on the ground, a concrete base at least 250 mm wider and longer than the unit's footprint should be laid. Furthermore, this base should withstand the unit weight mentioned in the technical data table.

Space requirements The units are air - cooled, then it is important to respect the minimum distances which guarantee the best ventilation of the condenser coils. Limitations of space reducing the air flow could cause significant reductions in cooling capacity and an increase in electricity consumption.

To determinate unit placement, careful consideration must be given to assure a sufficient air flow across the condenser heat transfer surface. Two conditions must be avoided to achieve the best performance: warm air recirculation and coil starvation. Both these conditions cause an increase of condensing pressures that results in reductions in unit efficiency and capacity. Moreover the unique microprocessor has the ability to calculate the operating environment of the air cooled chiller and the capacity to optimize its performance staying on - line during abnormal conditions.

Each side of the unit must be accessible after installation for periodic service. 'Fig.1' and 'Fig.2' shows you minimum recommended clearance requirements.

Vertical condenser air discharge must be unobstructed because the unit would have its capacity and efficiency significantly reduced. If the units are positioned in places surrounded by walls or obstacles of the same height as the units, the units should follow the minimum recommended clearance requirements shown in 'Fig.3 and Fig.4'. In the event the obstacles are higher than the units, the minimum recommended clearance requirements are shown in 'Fig.5 and Fig.6'. Units installed closer than the minimum recommended distance to a wall or other vertical riser may experience a combination of coil starvation and warm air recirculation, thus causing reduction in unit capacity and efficiency reductions. The microprocessor control is proactive in response "of design condition". In the case of single or compounded influences restricting airflow to the unit, the microprocessor will act to keep the compressor(s) running (at reduced capacity) rather than allowing a shut - off on high discharge pressure.

When two or more units are positioned side by side it is recommended that the condenser coils are at a minimum distance from one another as shown in 'Fig.7 and Fig.8'; strong wind could be the cause of air warm recirculation. For other installation solutions, consult our technicians.

The above recommended information are representative of general installation. A specific evaluation should be done by contractor depending on the case.

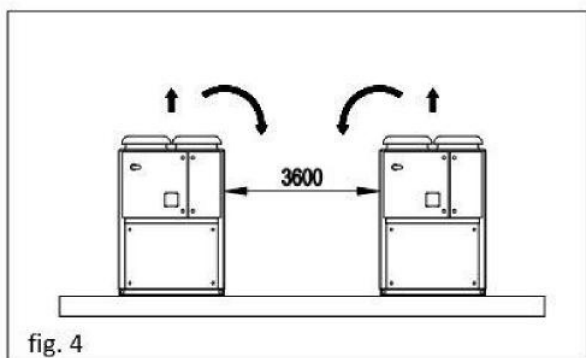
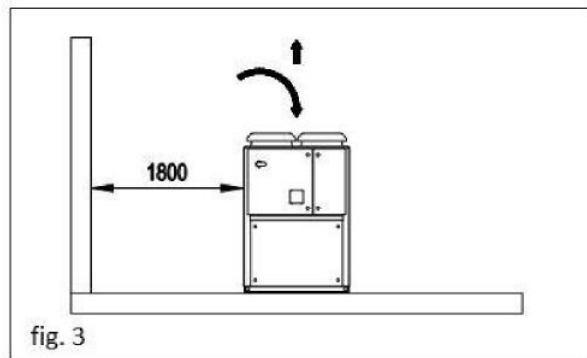
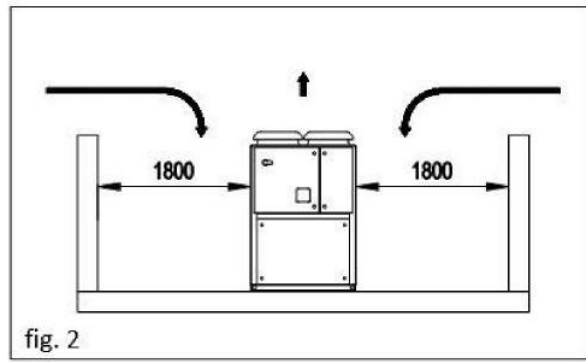
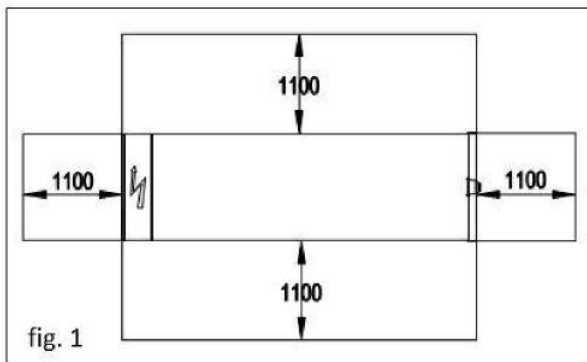

Acoustic protection

When noise level must meet special requirements, it is necessary to pay the maximum attention to ensure the perfect insulation of the unit from the support dampening devices on the unit, on the water pipes and on the electrical connections.

Storage The environment conditions have to be in the following limits:

Minimum ambient temperature: Maximum ambient temperature: Maximum R.H.:	-20°C +42°C 95% not condensing
---	--------------------------------------

Warning Installation and maintenance of the unit must to be performed only by qualified personnel who have knowledge with local codes and regulations, and experience with this type of equipment. Must be avoided the unit installation in places that could be considered dangerous for all the maintenance operations.

General The chiller will be designed and manufactured in accordance with the following European directives:

- Construction of pressure vessel 97/23/EC (PED)
- Machinery Directive 2006/42/EC
- Low Voltage 2006/95/EC
- Electromagnetic Compatibility 2004/108/EC
- Electrical & Safety codes EN 60204 – 1 / EN 60335 – 2 – 40
- Manufacturing Quality Standards UNI – EN ISO 9001:2004

To avoid any losses, the unit will be tested at full load in the factory (at the nominal working conditions and water temperatures). The chiller will be delivered to the job site completely assembled and charged with refrigerant and oil.

The installation of the chiller must comply with the manufacturer's instructions for rigging and handling equipment.

The unit will be able to start up and operate (as standard) at full load with:

- outside air temperature from °C to °C
- evaporator leaving fluid temperature between °C and °C

Refrigerant Only HFC 410A can be used.

Performance Chiller shall supply the following performances:

- Number of chiller(s) : unit(s)
 - Cooling capacity for single chiller : kW
 - Power input for single chiller in cooling mode : kW
 - Heat exchanger entering water temperature in cooling mode : °C
 - Heat exchanger leaving water temperature in cooling mode : °C
 - Heat exchanger water flow : l/s
 - Nominal outside working ambient temperature in cooling mode : °C
- Operating voltage range should be 400V ±10%, 3ph, 50Hz, voltage unbalance maximum 3%, without neutral conductor and shall only have one power connection point.

Unit description Chiller shall include as standard not less than: hermetic type rotary scroll compressors, electronic expansion device (EEXV), refrigerant direct expansion plate to plate heat exchanger, air - cooled condenser section, R - 410A refrigerant, motor starting components, control system and all components necessary for a safe and stable unit operation. The chiller will be factory assembled on a robust base frame made of galvanized steel, protected by an epoxy paint.

Sound level and vibrations Sound pressure level at 1 meter distance in free field, semispheric conditions, shall not exceed dB(A). The sound power levels must be rated in accordance to ISO 9614 (other types of rating can not be used).

Vibration on the base frame should not exceed 2 mm/s.

Dimensions Unit dimensions shall not exceed following indications:

- Unit length mm
- Unit width mm
- Unit height mm

Compressors The units shall be equipped with:

- High performance hermetic scroll compressors optimized to work with R410a, with reduced vibration and sound emissions. High efficiency values shall be guaranteed:
 - by high volumetric efficiency in the whole range of application, through the continuous contact between the fixed and the orbiting scroll deleting the dead space and the re - expansion of the refrigerant gas;
 - by low pressure drops due to the absence of inlet and discharge valves and to the uniform compression cycle;
 - reduction of the heat exchange between the gas during suction and discharge due to the separation of gas flows;
- The reduced noise shall be obtained:
 - for the absence of the inlet and discharge valves
 - for the uniform compression cycle
 - for the absence of pistons which ensures reduced vibration and pulsation of the refrigerant
- The engine shall be cooled by the suction refrigerant fluid.
- The terminal shall be contained in a casing with protection degree IP 54.
- The compressors shall be provided with crankcase heater to prevent the dilution of refrigerant and oil the during the stops of the unit;
- Shall be present an electronic thermal protection for the three phases complete with sensors on the stator windings to avoid overheating caused by lack of phase, insufficient cooling, mechanical locks, power supply out of tolerance;
- The compressors shall be connected in Tandem on a single refrigerating circuit.
- The compressors shall be fitted on rubber antivibration mounts.
- The compressors shall be provided complete with oil charge.

Evaporator (PHE) The units shall be equipped with a direct expansion plate to plate type evaporator.

- The evaporator will be made of of stainless steel brazed plates and shall be linked with an electrical heater to prevent freezing down to - 28°C ambient temperature, controlled by a thermostat and shall be insulated with flexible, closed cell polyurethane insulation material (20 - mm thick).
- The evaporator will have 1 refrigerant circuit.
- The water connections shall be treated type connections as standard to ensure quick mechanical disconnection between the unit and the hydronic network.

- The evaporator will be manufactured in accordance to PED approval.

Condenser coil The condenser is made entirely of aluminum with flat tubes containing small channels. Full - depth louvered aluminum fins are inserted between the tubes maximizing the heat exchange. The Microchannel technology ensures the highest performance with the minimum surface for the exchanger. The quantity of refrigerant is also reduced compared to Cu/Al condenser. Special treatment ensure resistance to the corrosion by atmospheric agents extending the life time.

Condenser fans The condenser fans used in conjunction with the condenser coils, shall be propeller type with glass reinforced resin blades for higher efficiencies and lower sound. Each fan shall be protected by a fan guard.

- The air discharge shall be vertical and each fan must be coupled to the electrical motor, supplied as standard to IP54 and capable to work to ambient temperatures of - 20°C to + 65°C.
- The condenser fans shall have as a standard an internally protection from overtemperature.

Refrigerant circuit The unit shall have one refrigerant circuit.

- The circuit shall include as standard: electronic expansion device piloted by unit's microprocessor control, sight glass with moisture indicator, charging valves, high pressure switch, high and low pressure transducers and insulated suction line.

Condensation control The units will be provided with an automatic control for condensing pressure which ensures the working at low external temperatures down to - °C, to maintain condensing pressure.

- The unit automatically unloads when abnormal high condensing pressure is detected. This to prevent the shutdown of the refrigerant circuit (shutdown of the unit) due to a high - pressure fault.

Low sound unit configurations (on request) The unit compressor shall be connected with unit's metal base frame by rubber antivibration supports to prevent the transmission of vibrations to all metal unit structure, in order to control the unit sound.

- The chiller shall be provided with an acoustical compressor enclosure. The compressor sound - proof enclosure shall be internally fitted with flexible, multi - layer, high density materials.

Hydronic kit options (on request) The hydronic module shall be integrated in the chiller chassis without increasing its dimensions and includes the following elements: centrifugal pump with motor protected by a circuit breaker installed in control panel, pressure gauge, safety valve, drain valve.

- The hydronic module shall be assembled and wired to the control panel.
- The water piping shall be protected against corrosion and freezing and insulated to prevent condensation.
- A choice of two pump types shall be available:
 - in - line single pump
 - in - line twin pumps
 - in - line single pump with tank
 - in - line twin pumps with tank.

Electrical control panel Power and control shall be located in the main panel that will be manufactured to ensure protection against all weather conditions.

- The electrical panel shall be IP54 and (when opening the doors) internally protected against possible accidental contact with live parts.
- The main panel shall be fitted with a main switch interlocked door that shuts off power supply when opening.
- The power section will include compressors and fans protection devices, compressors and fans starters and control circuit power supply.

Controller The controller will be installed as standard and it will be used to modify unit set - points and check control parameters.

- A built - in display will shows chiller operating status plus temperatures of water, refrigerant and air, programmable values, set - points.
- A sophisticated software with predictive logic, will select the most energy efficient combination of compressors, EEXV and condenser fans to keep stable operating conditions to maximize chiller energy efficiency and reliability.
- The controller will be able to protect critical components based on external signals from its system (such as motor temperatures, refrigerant gas and oil pressures, correct phase sequence, pressure switches and evaporator). The input coming from the high pressure switch cuts all digital output from the controller in less than 50ms, this will be an additional security for the equipment.
- Fast program cycle (200ms) for a precise monitoring of the system.
- Floating point calculations supported for increased accuracy in P/T conversions.

Controller main features: Controller shall grantee the following minimum functions

- Management of the refrigerant circuit capacity
- Full routine operation at condition of:
 - high thermal load
 - high evaporator entering water temperature (start - up)
- Display of evaporator entering/leaving water temperature.
- Display of condensing - evaporating temperature and pressure, suction superheat for each circuit.
- Leaving water evaporator temperature regulation .
- Compressor and pumps hours counter.
- Display of Status Safety Devices.
- Number of starts and compressor working hours.
- Optimized management of compressor load.

- Re - start in case of power failure (automatic / manual).
- Soft Load (optimized management of the compressor load during the start - up).
- OAT (Outside Ambient temperature) Reset.
- Start at high evaporator water temperature.
- Return Reset (Set Point Reset based on return water temperature).
- Set point Reset (optional).
- Application and system upgrade with commercial SD cards.

High Level Communications Interface (on request) The chiller shall be able to communicate to BMS (Building Management System) based on the most common protocols as:

- ModbusRTU
- LonWorks, now also based on the international 8040 Standard Chiller Profile and LonMark Technology
- BacNet BTP certifief over IP and MS/TP (class 4)
- Ethernet TCP/IP.

For more information email info@daikinapplied.uk or visit www.daikinapplied.uk

For all Daikin Applied UK,
Daikin Applied Service &
Spares enquiries call us on:
0345 565 2700



Daikin Europe N.V. participates in the Eurovent Certified Performance programme for Liquid Chilling Packages and Hydronic Heat Pumps, Fan Coil Units and Variable Refrigerant Flow systems. Check ongoing validity of certificate:
www.eurovent-certification.com

The present publication is drawn up by way of information only and does not constitute an offer binding upon Daikin Europe N.V. Daikin Europe N.V. has compiled the content of this publication to the best of its knowledge. No express or implied warranty is given for the completeness, accuracy, reliability or fitness for particular purpose of its content and the products and services presented therein. Specifications are subject to change without prior notice. Daikin Europe N.V. explicitly rejects any liability for any direct or indirect damage, in the broadest sense, arising from or related to the use and/or interpretation of this publication. All content is copyrighted by Daikin Europe N.V.

