

ERAD-E

Air cooled single
circuit condensing unit

Product manual

Wide capacity range (120 kW - 490 kW)
One refrigerant circuit with single screw compressor
Two sound versions available
Compact design
Large operation range (ambient down to -18°C)
Connectability with Daikin AHU's
Extensive option list including heat recovery
Refrigerant: R134a

CODE	ECDEN10-410
Date	-
Supersedes	-

Daikin Applied's new 'ERAD~E-' condensing unit range – the ideal match with our air handling units –

Available in two sound versions (standard and low)

Extensive capacity range composed of 10 sizes (cooling capacity from 120 to 490 kW)

The units are equipped with a R-134a single refrigerant circuit

Featuring a single screw compressor with stepless capacity control allowing the condensing unit to modulate its capacity from 100% to 25%.

Able to operate in ambient temperatures down to -18°C

Compact design

Extensive option list (including heat recovery, soft starter, etc.)

Table of content

ERAD-E

Features and benefits		4
General characteristics		7
Options		
Standard accessories		10
Options on request		11
Nomenclature		12
Technical and electrical specifications		13
ERAD E SS		13
ERAD E SL		15
Sound levels		17
Operating limits		19
Cooling capacity tables		
ERAD E SS		20
ERAD E SL		22
Heat recovery ratings		24
Dimensional drawings		27
Installation notes		29
Technical specification		33



The new single circuit condensing unit features

Application flexibility

The ERAD~E- series is available in a wide range of capacities - 10 different sizes from 120 kW up to 490 kW - and two sound configurations, making it an ideal match for smaller building applications.

Compact design

Each unit is equipped with a R-134a single refrigerant circuit, featuring a compact design with 2 up to 6 fans and thus making this series the perfect choice for retrofit projects.

Large operation range

The new range is available for ambient operating temperatures of -18°C up to 48°C, making the new condensing unit models suitable for comfort and process cooling applications in all climates.

Extensive option list

The base model includes several standard factory mounted options, such as: wye delta starter, phase monitor, hour run meter, etc. Moreover, the new range features an extensive option list, including: heat recovery, soft starter, different coil types, etc.

Superior control logic

The new MicroTech III controller provides an easy to use control environmental. The control logic is designed to provide maximum efficiency, to continue operation in unusual operating conditions and to provide a history of unit operation. One of the greatest benefits is the easy interface with LonWorks, BACnet, Ethernet TCP/IP or Modbus communications.

1 Features and advantages

Low operating cost

ERAD~E- is the result of careful design, aimed to optimize the energy efficiency of the condensing units, with the objective of bringing down operating costs and improving installation profitability, effectiveness and economical management.

The ERAD~E- condensing units use the new very high efficiency single rotor screw compressor design, large condenser coil surface area for maximum heat transfer and low discharge pressure, and advanced technology condenser fans.

Low operating sound levels

Very low sound levels both at full load and part load conditions are achieved by the latest compressor design and by a unique new fan that moves large volume of air at exceptionally low sound levels and by the virtually vibration-free operation.

Excellent serviceability

Field serviceability has not been sacrificed to meet design performance objectives. The compressor is equipped with discharge, liquid and suction shut off valves. The compressor and serviceable components such as filter driers are located on the outside edges of the base allowing easy access. The shaped of the coil allows easy access for inspection and service. The MicroTech III controller gives detailed information on the causes of an alarm or fault.

Proven reliability

Extensive quality control checks during testing and prior shipment guarantee the delivery of a state of the art product.

Infinite capacity control

Cooling capacity control is infinitely variable by means of a single screw compressor controlled by microprocessor system. Each unit has infinitely variable capacity control from 100% down to 25%. This modulation allows the compressor capacity to exactly match the required cooling load.

In case a compressor with load step control is used, the compressor capacity, at partial loads, will be too high or too low compared to the building cooling load. The result is an increase in unit energy costs, particularly at the part load conditions at which the unit operates most of the time.

The ERAD~E- condensing units with stepless regulation offer benefits that the units with step regulation are unable to match. Only a condensing unit with stepless regulation is able to follow the system's cooling demand at any time and to deliver chilled liquid or air at setpoint.

1 Features and advantages

Superior control logic

The new MicroTech III controller provides an easy to use control. The control logic is designed to guarantee a stable operation, to provide maximum efficiency, to continue operation in unusual operating conditions and to provide a history of unit operation. One of the greatest benefits is the easy interface with LonWorks, Bacnet, Ethernet TCP/IP or Modbus communications.

Code requirements – Safety and observant of laws/directives

All ERAD~E- units are designed and manufactured in accordance with applicable selections of the following:

Construction of pressure vessel	97/23/EC (PED)
Machinery Directive	2006/42/EC
Low Voltage	2006/95/EC
Electromagnetic Compatibility	2004/108/EC
Electrical & Safety codes	EN 60204-1 / EN 60335-2-40
Manufacturing Quality Stds	UNI – EN ISO 9001:2004

Certifications

All units manufactured by Daikin are CE marked, complying with European directives in force, concerning manufacturing and safety. On request units can be produced complying with laws in force in non-European countries (ASME, GOST, etc.), and with other applications, such as naval (RINA, etc.).

Versions

ERAD~E- is available in a Standard Efficiency version:

S: Standard Efficiency

10 sizes to cover a range from 116 up to 488 kW with an EER up to 3.30 (data referred to Standard Sound configuration)

The EER (Energy Efficiency Ratio) is the ratio of the Cooling Capacity to the Power Input of the unit. The Power Input includes: the power input for operation of the compressor and fans, the power input of all control and safety devices.

Sound configurations

ERAD~E- is available in two different sound level configurations:

S: Standard Sound

Condenser fan rotating at 920 rpm, rubber antivibration under compressor

L: Low Sound

Condenser fan rotating at 715 rpm, rubber antivibration under compressor, compressor sound enclosure

2 General characteristics

Cabinet and structure

The cabinet is made of galvanized steel sheet and painted to provide a high resistance to corrosion. Colour Ivory White (Munsell code 5Y7.5/1) (±RAL7044). The base frame has eye-hook for lifting the unit with ropes for an easy installation. The weight is uniformly distributed along the profiles of the base and this facilitates the arrangement of the unit.

Screw compressors with integrated oil separator

From size ERAD120E-SS to size ERAD250E-SS and from size ERAD120E-SL to size ERAD240E-SL

The compressor is semi-hermetic, single-screw type with one gate-rotor (made of carbon impregnated engineered composite material). The compressor has one slide managed by the unit microprocessor for infinitely modulating the capacity between 100% to 25%. An integrated high efficiency oil separator maximises the oil separation. Standard Start is Wye-delta (Y-Δ) type.

From size ERAD310E-SS to size ERAD490E-SS and from size ERAD300E-SL to size ERAD460E-SL

The compressor is semi-hermetic, single-screw type with gate-rotor (with the latest high-strength fibre reinforced star material). The compressor has an asymmetric slide regulation managed by the unit controller for infinitely modulating capacity between 100% to 25%. An integrated high efficiency oil separator maximizes the oil separation. Standard Start is Wye-delta (Y-Δ) type.

Ecological R-134a refrigerant

The compressors have been designed to operate with R-134a, ecological refrigerant with very low ODP (Ozone Depletion Potential) and GWP (Global Warming Potential) that means low TEWI (Total Equivalent Warming Impact).

Condenser coils

The condenser is manufactured with internally enhanced seamless copper tubes arranged in a staggered row pattern and mechanically expanded into lanced and rippled aluminium condenser fins with full fin collars. An integral sub-cooler circuit provides sub-cooling to effectively eliminate liquid flashing and increase the cooling capacity without increasing the power input.

Condenser fans

The condenser fans are propeller type with high efficiency design blades to maximize performances. The material of the blades is glass reinforced resin and each fan is protected by a guard. Fan motors are protected by circuit breakers installed inside the electrical panel as a standard. The motors are IP54.

Refrigerant circuit

Each unit has 1 refrigerant circuit and includes:

- Compressor with integrated oil separator
- Air Cooled Condenser
- Discharge line shut off valve
- Liquid line shut off valve
- Suction line shut off valve
- Sight glass with moisture indicator
- Filter drier
- Charging valves
- High pressure switch
- High and low pressure transducers

Electrical control panel

Power and control are located in the main panel that is manufactured to ensure protection against all weather conditions. The electrical panel is IP54 and (when opening the doors) internally protected with plexiglas panel against possible accidental contact with electrical components (IP20). The main panel is fitted with a main switch interlocked door.

2 General characteristics

Power Section

The power section includes compressors fuses, fan circuit breaker, fan contactors and control circuit transformer.

MicroTech III controller

MicroTech III controller is installed as standard; it can be used to modify unit set-points and check control parameters. A built-in display shows condensing unit operating status plus temperatures and pressures of liquid or air, refrigerant and air, programmable values, set-points. A sophisticated software with predictive logic, selects the most energy efficient combination of compressor, condenser fans to keep stable operating conditions to maximise condensing unit energy efficiency and reliability. MicroTech III is able to protect critical components based on external signs from its system (such as motor temperatures, refrigerant gas and oil pressures, correct phase sequence, pressure switches and evaporator). The input coming from the high pressure switch cuts all digital output from the controller in less than 50ms, this is an additional security for the equipment. Fast program cycle (200ms) for a precise monitoring of the system. Floating point calculations supported for increased accuracy in P/T conversions.

Control section - main features

- Management of the compressor stepless capacity and fans modulation.
- Condensing unit enabled to work in partial failure condition.
- Full routine operation at condition of:
 - high ambient temperature value
 - high thermal load
 - high evaporator entering liquid or air temperature (start-up)
- Display of liquid or air entering/leaving temperature.
- Display of Outdoor Ambient Temperature.
- Display of condensing-evaporating temperature and pressure, suction and discharge superheat for the circuit.
- Leaving liquid or air evaporator temperature regulation. Temperature tolerance = 0,1°C.
- Compressor hours counter.
- Display of Status Safety Devices.
- Number of starts and compressor working hours.
- Optimized management of compressor load.
- Fan management according to condensing pressure.
- Re-start in case of power failure (automatic / manual).
- Soft Load (optimized management of the compressors load during the start-up).
- Start at high evaporator liquid or air temperature.
- Return Reset (Set Point Reset based on return of liquid or air temperature of evaporating section).
- OAT (Outside Ambient temperature) Reset.
- Set point Reset (optional).
- Application and system upgrade with commercial SD cards.
- Ethernet port for remote or local servicing using standard web browsers.
- Two different sets of default parameters could be stored for easy restore.

2 General characteristics

Safety device / logic for each refrigerant circuit

- High pressure (pressure switch).
- High pressure (transducer).
- Low pressure (transducer).
- Fans circuit breaker.
- High compressor discharge temperature.
- High motor winding temperature.
- Phase Monitor.
- Low pressure ratio.
- High oil pressure drop.
- Low oil pressure.
- No pressure change at start.

System security

- Phase monitor.
- Low Ambient temperature lock-out.
- Freeze protection.

Regulation type

Proportional + integral + derivative regulation on the leaving water evaporator output probe.

Condensing pressure

Condensing pressure can be controlled in according to the entering air temperature to the condenser coil. The fans can be managed either with steps, or with a 0/10 V modulating signal or with a mixed 0/10V + Steps strategy to cover all possible operational conditions.

MicroTech III

MicroTech III built-in terminal has the following features.

- 164x44 dots liquid crystal display with white back lighting. Supports Unicode fonts for multi-lingual.
- Key-pad consisting of 3 keys.
- Push'n'Roll control for an increased usability.
- Memory to protect the data.
- General faults alarm relays.
- Password access to modify the setting.
- Application security to prevent application tampering or hardware usability with third party applications.
- Service report displaying all running hours and general conditions.
- Alarm history memory to allow an easy fault analysis.

Supervising systems (on request)

MicroTech III remote control

MicroTech III is able to communicate to BMS (Building Management System) based on the most common protocols as:

- ModbusRTU
- LonWorks, now also based on the international 8040 Standard Chiller Profile and LonMark Technology
- BacNet BTP certified over IP and MS/TP (class 4) (Native)
- Ethernet TCP/IP.

2 General characteristics

Standard accessories (supplied on basic unit)

Wye-Delta Compressors starter (Y-Δ) – For low inrush current and reduced starting torque.

Double set-point – Dual leaving liquid or air temperature set-points.

Fans circuit breakers thermal overload relays – Safety devices against fan motor overloading in addition to the normal protection envisaged by the electrical windings.

Phase monitor – The phase monitor controls that phases sequence is correct and controls phase loss.

Discharge line shut off valves – Installed on the discharge port of the compressor to facilitate maintenance operation.

Suction line shut off valve – Installed on the suction port of the compressor to facilitate maintenance operation.

Ambient outside temperature sensor and set-point reset

Hour run meter

General fault contactor – Alarm relay.

Set-point reset – The leaving liquid or air temperature set-point can be overwritten with the following options: 4-20mA from external source (by user); outside ambient temperature; evaporator liquid or air temperature Δt .

Demand limit – User can limit the load of the unit by 4-20mA signal or by network system

Alarm from external device – Microprocessor is able to receive an alarm signal from an external device (pump etc...). User can decide if this alarm signal will stop or not the unit.

Fans circuit breakers – Safety device against motor overloading and short circuit

Main switch interlock door

2 General characteristics

Options (on request)

Total heat recovery – Provided with plate to plate heat exchangers to produce hot water.

Partial heat recovery – Plate to plate heat exchangers installed between the compressor discharge and the condenser coil, allowing to produce hot water.

Soft starter – Electronic starting device to reduce the mechanical stress during compressor start-up.

Compressor thermal overload relays – Safety devices against compressor motor overloading. This device together with internal motor protection (standard) guarantee the best safety system for compressor motor.

Under/Over Voltage – This device control the voltage value of power supply and stop the chiller if the value exceeds the allowed operating limits.

Energy Meter – This device allows to measure the energy absorbed by the condensing unit during its life. It is installed inside the control box mounted on a DIN rail and show on a digital display: Line-to-Line Voltage, Phase and Average Current, Active and Reactive Power, Active Energy, Frequency.

Capacitors for power factor correction – To increase the operating power factor of the unit at nominal operating conditions. The capacitors are “dry” self-regenerating type with over pressure disconnecting safety device insulated with a no toxic dielectric mix with no PCB or PCT.

Current limit – To limit maximum absorbed current of the unit whenever is required

Fan speed regulation – To control the fan speed revolution for smooth operating control of the unit during low ambient temperature operation. This option improves also the sound level of the unit.

With “Fan speed regulation” option, by different microprocessor setting, it is also possible to set the “Fan Silent Mode” configuration. It means that the microprocessor clock switches the fan at low speed according to the client setting (i.e. Night & Day), providing that the ambient temperature/condensing pressure is allowing the speed change.

It allows a perfect condensing control down to -10°C .

Speedtrol – Continuous fan speed modulation on the first fan of the circuit. It allows the unit working with air temperature down to -18°C .

Condenser coil guards

Cu-Cu condensing coils – To give better protection against corrosion in aggressive environments.

Cu-Cu-Sn condensing coils – To give better protection against corrosion in aggressive and in salty air environments.

Alucoat condensing coils – Fins are protected by a special acrylic paint with a high resistance to corrosion.

High pressure side manameter

Kit container

Rubber type anti vibration mounts – Supplied separately, these are positioned under the base of the unit during installation to reduce vibrations.

Spring type anti vibration mounts – Supplied separately, these are positioned under the base of the unit during installation. Ideal for dampening vibrations for installation on roofs and metallic structures.

Double pressure relief valve with diverter

Compressors circuit breakers

3 Nomenclature

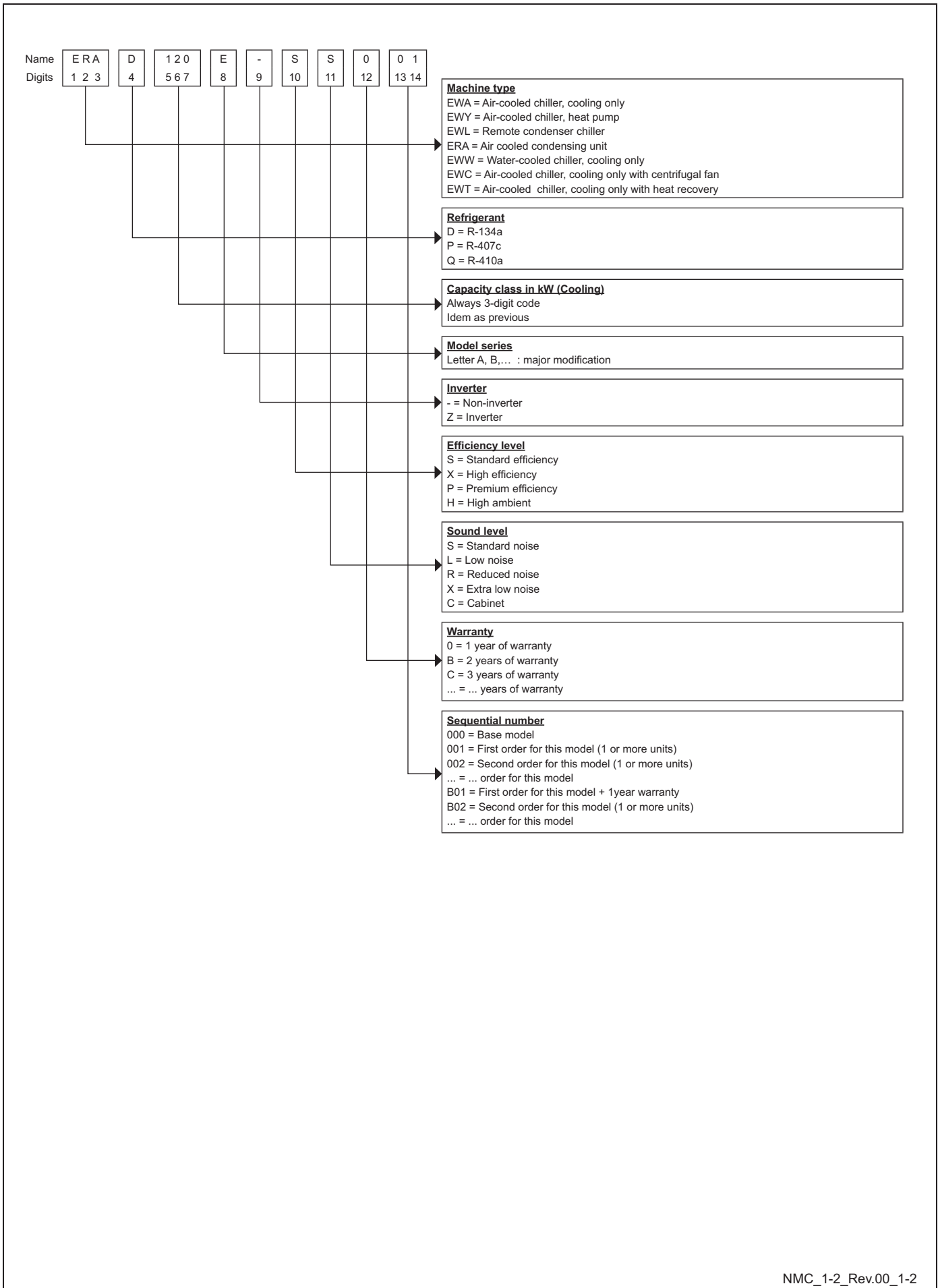

4 Technical specifications

4-1 Technical Specifications			ERAD-E-SS	120	140	170	200	220	250	310	370	440	490	
Capacity (1)	Cooling	kW	121	144	165	196	219	252	306	370	435	488		
Capacity control	Type	---	Stepless											
	Minimum capacity	%	25											
Unit power input (1)	Cooling	kW	41.8	51.0	57.4	65.2	73.7	76.6	92.8	122.0	147.2	160.8		
EER (1)		---	2.90	2.83	2.87	3.00	2.97	3.28	3.30	3.04	2.96	3.03		
Casing	Colour	---	Ivory White											
	Material	---	Galvanized and painted steel sheet											
Dimensions	Unit	Height	mm	2,273						2,223				
		Width	mm	1,292						2,236				
		Length	mm	2,165			3,065			3,070				
Weight	Unit	kg	1,564	1,587	1,698	1,739	1,886	1,928	2,355	2,559	2,642	2,677		
	Operating Weight	kg	1,594	1,620	1,733	1,779	1,928	1,973	2,416	2,623	2,715	2,754		
Air heat exchanger	Type	---	High efficiency fin and tube type with integral subcooler											
Fan	Type	---	Direct propeller type											
	Drive	---	DOL											
	Diameter	mm	800											
	Nominal air flow	l/s	10,922	10,575	16,383	15,863	21,844	21,150	32,767	32,767	31,725	31,725		
	Model	Quantity	No.	2		3		4		6				
		Speed	rpm	920										
Motor input		W	1.75											
Compressor	Type	---	Semi-hermetic single screw compressor											
	Oil charge	l	13						16		19			
	Quantity	No.	1											
Sound level	Sound Power	Cooling	dB(A)	91.5		92.3		93.0		94.2		94.5		95.2
	Sound Pressure (2)	Cooling	dB(A)	73.5		73.7		73.9		75.1		75.0		75.3
Refrigerant circuit	Refrigerant type	---	R-134a											
	Refrigerant charge	kg.	17	20	22	27	29	32	45		54		58	
	N. of circuits	No.	1											
Piping connections	Suction	mm	76						139.7					
	Liquid	mm	28						35					
Safety devices	High discharge pressure (pressure switch)													
	High discharge pressure (pressure transducer)													
	Low suction pressure (pressure transducer)													
	Compressor motor protection													
	High discharge temperature													
	Low oil pressure													
	Low pressure ratio													
	High oil filter pressure drop													
	Phase monitor													
Notes (1)	Cooling capacity, unit power input in cooling and EER are based on the following conditions: SST 7°C; ambient 35°C, unit at full load operation.													
Notes (2)	The values are according to ISO 3744 and are referred to: SST 7°C, ambient 35°C, full load operation.													
Notes (3)	Refrigerant charge is for the unit only; doesn't include external suction and liquid line. Units are shipped without refrigerant charge; holding charge nitrogen 0.5 bar													

4 Technical specifications

4-1 Electrical Specifications		ERAD~E-SS	120	140	170	200	220	250	310	370	440	490	
Power Supply	Phase	---	3										
	Frequency	Hz	50										
	Voltage	V	400										
	Voltage Tolerance	Minimum	%	-10%									
		Maximum	%	+10%									
Unit	Maximum starting current	A	159		207		304		354	434			
	Nominal running current cooling	A	72	87	98	110	127	131	156	203	243	265	
	Maximum running current	A	88	104	119	133	161		195	248	288		
	Maximum current for wires sizing	A	97	114	131	146	177		215	273	317		
Fans	Nominal running current in cooling	A	8		12		16		24				
Compressor	Phase	No.	3										
	Voltage	V	400										
	Voltage Tolerance	Minimum	%	-10%									
		Maximum	%	+10%									
	Maximum running current	A	80	96	107	121	145		171	410	264		
	Starting method	---	Wye – Delta type (Y – Δ)										
Notes	Allowed voltage tolerance ± 10%. Voltage unbalance between phases must be within ± 3%.												
	Maximum starting current: starting current of biggest compressor + fans current.												
	Nominal current in cooling mode is referred to the following conditions: evaporator 12°C/7°C; ambient 35°C.compressor + fans current.												
	Maximum running current is based on max compressor absorbed current in its envelope and max fans absorbed current												
	Maximum unit current for wires sizing is based on minimum allowed voltage												
Maximum current for wires sizing: (compressors full load ampere + fans current) x 1,1.													

4 Technical specifications

4-1 Technical Specifications		ERAD~E-SL	120	140	160	190	210	240	300	350	410	460	
Capacity (1)	Cooling	kW	116.0	137	159	187	209	243	295	352	409	462	
Capacity control	Type	---	Stepless										
	Minimum capacity	%	25										
Unit power input (1)	Cooling	kW	42.3	52.5	57.6	66.3	73.9	78.2	91.5	122	150	167	
EER (1)		---	2.74	2.61	2.75	2.82	2.83	3.11	3.23	2.88	2.73	2.76	
Casing	Colour	---	Ivory White										
	Material	---	Galvanized and painted steel sheet										
Dimensions	Unit	Height	2,273					2,223					
		Width	1,292					2,236					
		Length	2,165			3,065			3,965			3,070	
Weight	Unit	kg	1,712	1,738	1,851	1,897	2,046	2,091	2,534	2,741	2,834	2,870	
	Operating Weight	kg	1,742	1,771	1,886	1,937	2,088	2,136	2,595	2,805	2,907	2,950	
Air heat exchanger	Type	---	High efficiency fin and tube type with integral subcooler										
Fan	Type	---	Direct propeller type										
	Drive	---	DOL										
	Diameter	mm	800										
	Nominal air flow	l/s	8,372	8,144	12,558	12,217	16,744	16,289	25,117		24,433		
	Model	Quantity	No.	2		3		4		6			
		Speed	rpm	715									
Motor input		W	0.78										
Compressor	Type	---	Semi-hermetic single screw compressor										
	Oil charge	l	13					16		19			
	Quantity	No.	1										
Sound level	Sound Power	Cooling	89.0		89.8		90.5		91.7		92.0		92.7
	Sound Pressure (2)	Cooling	71.0		71.2		71.4		72.6		72.8		73.5
Refrigerant circuit	Refrigerant type	---	R-134a										
	Refrigerant charge	kg.	17	20	22	27	29	32	45		54	58	
	N. of circuits	No.	1										
Piping connections	Suction	mm	76							139.7			
	Liquid	mm	28					35					
Safety devices	High discharge pressure (pressure switch)												
	High discharge pressure (pressure transducer)												
	Low suction pressure (pressure transducer)												
	Compressor motor protection												
	High discharge temperature												
	Low oil pressure												
	Low pressure ratio												
	High oil filter pressure drop												
	Phase monitor												
Notes (1)	Cooling capacity, unit power input in cooling and EER are based on the following conditions: SST 7°C; ambient 35°C, unit at full load operation.												
Notes (2)	The values are according to ISO 3744 and are referred to: SST 7°C, ambient 35°C, full load operation.												
Notes (3)	Refrigerant charge is for the unit only; doesn't include external suction and liquid line. Units are shipped without refrigerant charge; holding charge nitrogen 0.5 bar												

4 Technical specifications

4-1 Electrical Specifications		ERAD~E-SL	120	140	160	190	210	240	300	350	410	460	
Power Supply	Phase	---	3										
	Frequency	Hz	50										
	Voltage	V	400										
	Voltage Tolerance	Minimum	%	-10%									
		Maximum	%	+10%									
Unit	Maximum starting current	A	156		203		298		346	426			
	Nominal running current cooling	A	73	90	98	111	127	298	346	426			
	Maximum running current	A	85	101	115	129	155	133	154	203	248	274	
	Maximum current for wires sizing	A	94	111	126	142	171		205	264	308		
Fans	Nominal running current in cooling	A	5.2		7.8		10.4		15.6				
Compressor	Phase	No.	3										
	Voltage	V	400										
	Voltage Tolerance	Minimum	%	-10%									
		Maximum	%	+10%									
	Maximum running current	A	80	96	107	121	145		171	410	264		
	Starting method	---	Wye – Delta type (Y – Δ)										
Notes	Allowed voltage tolerance ± 10%. Voltage unbalance between phases must be within ± 3%.												
	Maximum starting current: starting current of biggest compressor + fans current												
	Nominal current in cooling mode is referred to the following conditions: evaporator 12°C/7°C; ambient 35°C.compressor + fans current.												
	Maximum running current is based on max compressor absorbed current in its envelope and max fans absorbed current												
	Maximum unit current for wires sizing is based on minimum allowed voltage												
Maximum current for wires sizing: (compressors full load ampere + fans current) x 1,1.													

5 Sound Levels

ERAD-E-SS

Unit size	Sound pressure level at 1 m from the unit in semispheric free field (rif. 2×10^{-5} Pa)									Power
	63 Hz	125 Hz	250 Hz	500 Hz	1000 Hz	2000 Hz	4000 Hz	8000 Hz	dB(A)	dB(A)
120	75.5	70.8	68.9	75.3	64.3	61.7	53.0	47.3	73.5	91.5
140	75.5	70.8	68.9	75.3	64.3	61.7	53.0	47.3	73.5	91.5
170	75.7	71.0	69.1	75.5	64.5	61.9	53.2	47.5	73.7	92.3
200	75.7	71.0	69.1	75.5	64.5	61.9	53.2	47.5	73.7	92.3
220	75.9	71.2	69.3	75.7	64.7	62.1	53.4	47.7	73.9	93.0
250	77.1	72.4	70.5	76.9	65.9	63.3	54.6	48.9	75.1	94.2
310	77.0	72.3	70.4	76.8	65.8	63.2	54.5	48.8	75.0	94.2
370	77.3	72.6	70.7	77.1	66.1	63.5	54.8	49.1	75.3	94.5
440	77.3	72.6	70.7	77.1	66.1	63.5	54.8	49.1	75.3	94.5
490	78.0	73.3	71.4	77.8	66.8	64.2	55.5	49.8	76.0	95.2

ERAD-E-SL

Unit size	Sound pressure level at 1 m from the unit in semispheric free field (rif. 2×10^{-5} Pa)									Power
	63 Hz	125 Hz	250 Hz	500 Hz	1000 Hz	2000 Hz	4000 Hz	8000 Hz	dB(A)	dB(A)
120	73.0	68.3	66.4	72.8	61.8	59.2	50.5	44.8	71.0	89.0
140	73.0	68.3	66.4	72.8	61.8	59.2	50.5	44.8	71.0	89.0
160	73.2	68.5	66.6	73.0	62.0	59.4	50.7	45.0	71.2	89.8
190	73.2	68.5	66.6	73.0	62.0	59.4	50.7	45.0	71.2	89.8
210	73.4	68.7	66.8	73.2	62.2	59.6	50.9	45.2	71.4	90.5
240	74.6	69.9	68.0	74.4	63.4	60.8	52.1	46.4	72.6	91.7
300	74.5	69.8	67.9	74.3	63.3	60.7	52.0	46.3	72.5	91.7
350	74.8	70.1	68.2	74.6	63.6	61.0	52.3	46.6	72.8	92.0
410	74.8	70.1	68.2	74.6	63.6	61.0	52.3	46.6	72.8	92.0
460	75.5	70.8	68.9	75.3	64.3	61.7	53.0	47.3	73.5	92.7

NOTES

The values are according to ISO 3744 and are referred to: evaporator 12/7° C. air ambient 35° C. full load operation

5 Sound Levels

Sound pressure level reduction values for different distances

Unit size		Distance						
ERAD~E-SS	ERAD~E-SL	1m	5m	10m	15m	20m	25m	50m
120	120	0.0	-8.8	-13.9	-17.1	-19.4	-21.2	-27.0
140	140	0.0	-8.8	-13.9	-17.1	-19.4	-21.2	-27.0
170	160	0.0	-8.5	-13.5	-16.6	-18.9	-20.7	-26.5
200	190	0.0	-8.5	-13.5	-16.6	-18.9	-20.7	-26.5
220	210	0.0	-8.2	-13.1	-16.2	-18.4	-20.3	-26.0
250	240	0.0	-8.2	-13.1	-16.2	-18.4	-20.3	-26.0
310	300	0.0	-8.1	-13.0	-16.1	-18.4	-20.2	-25.9
370	350	0.0	-8.1	-13.0	-16.1	-18.4	-20.2	-25.9
440	410	0.0	-8.1	-13.0	-16.1	-18.4	-20.2	-25.9
490	460	0.0	-8.1	-13.0	-16.1	-18.4	-20.2	-25.9

6 Operating limits

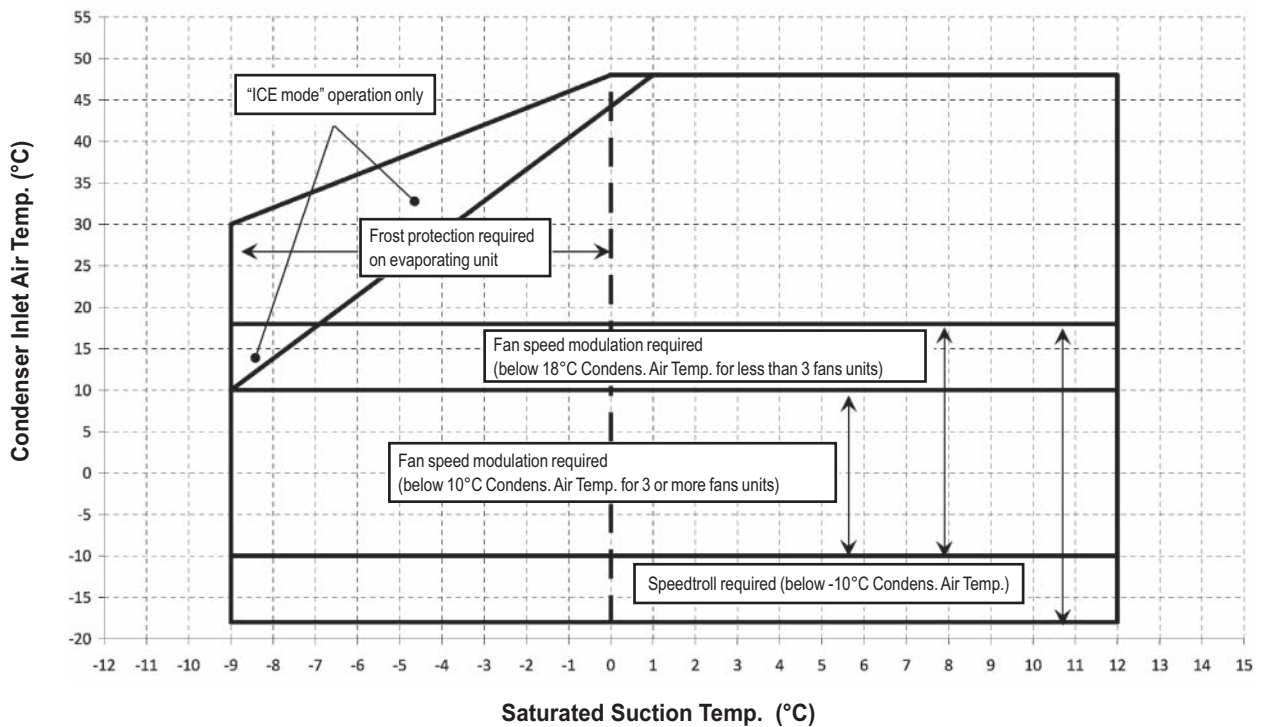

OPL_1-2_Rev.00_1

Table 1 - Air heat exchanger - Altitude correction factors

Elevation above sea level (m)	0	300	600	900	1200	1500	1800
Barometric pressure (mbar)	1,013	977	942	908	875	843	812
Cooling capacity correction factor	1.000	0.993	0.986	0.979	0.973	0.967	0.960
Power input correction factor	1.000	1.005	1.009	1.015	1.021	1.026	1.031

- Maximum operating altitude is 2000 m above sea level

- Contact factory in case the unit has to be installed at altitudes between 1000 and 2000 m above sea level

OPL_1-2_Rev.00_2

7 Standard rating

7 - 1 Cooling capacity tables

ERAD~E-SS		Condenser Inlet Air Temperature (°C)													
Size	SST (°C)	20		25		30		35		40		45		48	
		Cc (kW)	Pi (kW)	Cc (kW)	Pi (kW)	Cc (kW)	Pi (kW)	Cc (kW)	Pi (kW)	Cc (kW)	Pi (kW)	Cc (kW)	Pi (kW)	Cc (kW)	Pi (kW)
310	-9	200	58.5	189	63.5	179	69	168	76.1	157	84.1	143	93.7	134	100
	-7	216	60.2	205	65.2	194	71	183	77.6	170	85.4	156	94.8	146	101
	-5	233	62.0	222	67.0	210	73	198	79.2	185	86.9	169	96.1	159	102
	-3	251	64.0	239	68.9	227	75	214	81.0	200	88.6	184	97.6	173	104
	-1	270	66.2	258	71.1	245	77	231	83.0	216	90.5	198	99.3	187	105
	1	291	68.5	277	73.4	263	79	249	85.2	232	92.6	214	101	202	107
	3	312	71.0	297	75.9	283	81	267	87.5	250	94.8	230	103	217	109
	5	334	73.7	318	78.5	303	84	286	90.1	268	97.3	247	106	233	111
	7	356	76.6	341	81.4	324	87	306	92.8	286	100	265	108	250	114
	9	380	79.7	363	84.4	346	90	327	95.8	306	103	283	111	267	116
11	405	82.9	387	87.6	369	93	348	98.9	326	106	302	114	286	119	
13	418	84.6	400	89.3	380	95	359	101	337	108	311	115	288	118	
370	-9	248	74.4	234	80.0	221	86	207	91.9	192	98.4	174	106	162	110
	-7	268	77.1	254	82.8	240	89	225	95.1	208	102	189	109	177	114
	-5	289	79.9	274	85.8	259	92	243	99	225	106	205	113	192	118
	-3	311	82.8	295	88.9	279	95	262	102	243	109	222	117	208	122
	-1	334	85.9	318	92.2	301	99	282	106	262	113	239	121	224	126
	1	359	89.2	341	95.6	323	102	303	110	281	117	257	125	241	130
	3	384	92.6	365	99.2	346	106	325	114	301	121	276	130	259	135
	5	410	96.2	391	103	370	110	347	118	322	126	295	134	269	136
	7	438	100	417	107	394	114	370	122	344	130	315	139	273	133
	9	466	104	444	111	420	119	394	127	366	135	335	144	275	128
11	496	108	472	116	446	123	419	131	389	140	339	141	281	125	
13	511	110	486	118	460	126	432	134	401	143	340	138	282	123	
440	-9	294	88.5	278	95.3	262	102	246	110	227	118	205	126	191	132
	-7	318	91.9	301	98.8	284	106	266	114	246	122	223	131	208	136
	-5	343	95.4	325	103	307	110	288	118	266	126	241	135	225	141
	-3	369	99.1	350	106	331	114	310	122	287	131	261	140	243	146
	-1	396	103	376	111	356	118	333	127	308	136	281	145	262	152
	1	425	107	404	115	382	123	358	132	331	141	301	151	282	157
	3	455	111	432	119	408	128	383	137	354	146	323	156	294	158
	5	485	116	462	124	436	133	409	142	378	152	345	162	296	153
	7	517	121	492	129	465	138	435	147	403	157	368	168	302	149
	9	551	126	523	134	495	143	463	153	429	163	370	163	306	144
11	585	131	556	140	525	149	492	159	455	169	376	159	311	140	
13	602	134	572	143	540	152	506	162	469	173	379	157	311	137	
490	-9	325	94.5	315	103	304	112	292	121	277	131	256	143	240	151
	-7	349	97.9	338	107	327	116	314	125	297	136	275	148	258	156
	-5	374	101	362	111	351	120	337	130	318	141	294	153	277	161
	-3	400	105	388	115	375	124	360	134	340	146	315	158	288	162
	-1	427	109	414	119	401	129	384	139	363	151	335	164	293	159
	1	455	113	442	123	427	133	409	144	386	156	357	169	298	155
	3	484	118	470	128	454	138	435	150	410	162	365	168	300	149
	5	515	122	500	133	482	144	461	155	434	167	370	164	304	145
	7	546	127	530	138	511	149	488	161	459	174	372	159	309	141
	9	579	132	561	143	541	155	516	167	485	180	377	155	313	137
11	613	138	594	149	571	161	544	173	493	178	383	152	316	133	
13	630	141	610	152	587	164	558	176	494	176	386	150	317	130	

NOTES

Cc (cooling capacity) - Pi (unit power input) – SST (compressor saturated suction temperature)

7 Standard rating

7 - 1 Cooling capacity tables

ERAD~E-SL															
Size	SST (°C)	Condenser Inlet Air Temperature (°C)													
		20		25		30		35		40		45		48	
		Cc (kW)	Pi (kW)	Cc (kW)	Pi (kW)	Cc (kW)	Pi (kW)	Cc (kW)	Pi (kW)	Cc (kW)	Pi (kW)	Cc (kW)	Pi (kW)	Cc (kW)	Pi (kW)
300	-9	185	58.9	186	60.3	175	66.3	164	73.5	152	82.0	138	92.0	128	98.9
	-7	200	61.0	201	62.0	190	68.0	178	75.1	165	83.4	150	93.3	140	100.0
	-5	223	60.4	217	64.0	205	69.9	193	76.9	179	85.1	163	94.7	152	101.3
	-3	240	62.7	234	66.1	222	72.0	208	78.8	194	86.9	176	96.4	165	102.8
	-1	264	63.3	252	68.4	239	74.2	224	81.0	208	88.9	190	98.2	178	104.5
	1	284	65.7	270	70.8	256	76.6	241	83.3	224	91.2	205	100.3	192	106.4
	3	304	68.4	290	73.4	275	79.2	258	85.8	240	93.6	220	102.6	206	108.6
	5	325	71.2	310	76.3	294	82.0	277	88.6	257	96.2	236	105.1	221	111.0
	7	347	74.3	331	79.3	314	85.0	295	91.5	275	99.1	252	107.8	228	109.1
	9	369	77.5	352	82.5	334	88.2	315	94.6	293	102.1	269	110.7	233	105.6
	11	393	80.9	375	85.9	356	91.6	335	98.0	312	105.4	286	113.9	237	101.7
	13	405	82.7	386	87.7	367	93.3	345	100	321	107.1	289	112.8	238	99.6
	350	-9	242	71.7	229	77.3	215	83.2	201	89.4	185	96.0	166	103.2	154
-7		261	74.7	247	80.4	233	86.5	218	92.9	200	99.8	181	107.2	167	111.9
-5		281	77.8	266	83.7	251	90.0	235	96.6	216	103.7	195	111.3	181	116.2
-3		302	81.0	287	87.2	270	93.6	253	100	233	107.7	211	115.6	196	120.6
-1		324	84.4	308	90.8	290	97.4	271	104	250	112.0	226	120.1	211	125.2
1		347	88.1	330	94.5	311	101.4	291	109	268	116.4	243	124.7	215	123.5
3		371	91.9	353	98.5	332	105.6	311	113	286	121.0	259	129.5	219	120.2
5		396	95.9	376	102.7	355	110.0	331	118	305	125.8	270	130.6	222	115.7
7		422	100.1	400	107.1	377	114.6	352	122	325	130.8	273	127.2	227	112.9
9		448	104.5	425	111.8	401	119.4	374	128	345	136.1	278	123.9	228	108.0
11		475	109.2	451	116.6	425	124.5	396	133	365	141.6	281	119.8	234	105.3
13		489	111.7	464	119.2	437	127.1	407	136	366	139.6	283	117.3	236	103.8
410		-9	286	87.0	270	93.7	254	100.8	236	108	217	116.4	194	125.1	179
	-7	308	90.7	292	97.7	274	105.0	256	113	234	121.1	210	130.1	194	135.8
	-5	332	94.6	314	101.8	296	109.4	276	117	253	126.0	227	135.3	210	141.1
	-3	356	98.8	338	106.2	318	114.0	296	122	272	131.1	244	140.6	225	146.1
	-1	382	103.1	362	110.7	341	118.8	317	127	291	136.5	262	146.2	229	142.6
	1	409	107.7	387	115.5	365	123.8	339	133	312	142.0	281	152.1	231	137.3
	3	437	112.5	414	120.6	389	129.1	362	138	332	147.8	288	151.0	236	133.3
	5	465	117.6	441	125.9	414	134.7	385	144	354	153.9	293	146.9	242	129.9
	7	495	123.0	468	131.5	440	140.6	409	150	376	160.3	298	143.0	246	125.7
	9	525	128.7	497	137.5	466	146.7	434	157	391	162.9	302	137.9	249	120.8
	11	556	134.7	526	143.7	493	153.2	458	163	395	158.4	307	133.6	254	116.9
	13	571	137.8	540	146.9	507	156.5	471	167	398	156.5	307	130.3	256	114.8
	460	-9	319	94.4	308	103.0	297	112.0	284	122	265	132.9	241	145.3	219
-7		342	98.3	331	107.2	319	116.5	304	127	284	138.0	258	150.7	224	146.6
-5		366	102.4	355	111.6	342	121.2	325	132	303	143.4	276	156.3	227	141.7
-3		391	106.7	379	116.2	365	126.2	347	137	323	149.0	284	156.1	231	137.3
-1		417	111.3	404	121.1	388	131.4	369	143	344	154.8	287	151.5	235	133.8
1		444	116.1	430	126.2	413	136.8	391	148	364	160.8	291	147.0	241	130.7
3		472	121.2	457	131.6	438	142.6	414	154	385	167.1	296	143.1	243	125.2
5		501	126.6	484	137.3	463	148.6	438	161	390	164.6	300	138.4	249	122.7
7		531	132.4	512	143.3	489	154.9	462	167	394	160.3	305	134.9	251	117.9
9		561	138.4	541	149.7	516	161.5	486	174	400	156.7	309	130.7	256	114.7
11		592	144.8	569	156.4	543	168.5	497	174.5	404	152.2	311	126.1	259	111.1
13		608	148.2	584	159.9	556	172.1	499	172.4	403	148.6	312	123.6	258	108.2

NOTES

Cc (cooling capacity) - Pi (unit power input) - SST (compressor saturated suction temperature)

8 Options

Total Heat Recovery Ratings

EWC/LWC	ERAD-E-SS	ERAD-E-SL	Cc (kW)	Pi (kW)	Hc (kW)	% Hc	EER Hc
40/45	120	120	108	39.1	125	85%	5.96
	140	140	129	47.4	150	85%	5.87
	170	160	147	53.9	171	85%	5.90
	200	190	174	61.0	200	85%	6.13
	220	210	194	69.6	224	85%	6.00
	250	240	231	78.3	263	85%	6.31
	310	300	273	93.4	311	85%	6.25
	370	350	325	118	377	85%	5.95
	440	410	382	142	393	75%	5.47
490	460	444	158	392	65%	5.28	
40/50	120	120	103	39.5	121	85%	5.67
	140	140	123	48.0	145	85%	5.58
	170	160	140	54.4	165	85%	5.61
	200	190	166	61.6	193	85%	5.83
	220	210	185	70.4	217	85%	5.71
	250	240	220	79.0	254	85%	6.01
	310	300	260	94.3	301	85%	5.95
	370	350	310	119	365	85%	5.67
	440	410	364	143	380	75%	5.20
490	460	424	160	379	65%	5.02	
45/55	120	120	103	40.0	85.8	60%	4.72
	140	140	123	48.5	103	60%	4.65
	170	160	140	55.0	117	60%	4.67
	200	190	166	62.4	137	60%	4.86
	220	210	185	71.2	154	60%	4.76
	250	240	220	79.8	180	60%	5.02
	310	300	260	95.2	213	60%	4.97
	370	350	310	120	258	60%	4.72
	440	410	364	144	254	50%	4.28
490	460	424	162	252	43%	4.18	

NOTES

Cc (cooling capacity)
 Pi (unit power input)
 Hc (heating heat recovery capacity)
 %Hc (percentage heat recovered)
 EER Hc (coefficient of performance during heat recovery = (cooling+ heating capacity) / power input)

EWC (Entering water heat recovery condenser)
 LWC (Leaving water heat recovery condenser)

Data are referred to:
 SST (compressor saturated suction temperature) = 7°C
 Condenser Inlet Air Temperature = 35°C
 0.0176 m² °C/kW evaporator fouling factor

OPT_1-2-3-4-5_Rev.00_1

Partial Heat Recovery Ratings

EWC/LWC	ERAD-E-SS	ERAD-E-SL	Cc (kW)	Pi (kW)	Hc (kW)	% Hc	EER Hc
50/60	120	120	103	40.8	50.3	35%	3.76
	140	140	123	49.5	60.3	35%	3.70
	170	160	140	56.1	68.6	35%	3.72
	200	190	166	63.6	80.3	35%	3.87
	220	210	185	72.6	90.1	35%	3.79
	250	240	220	80.6	105	35%	4.04
	310	300	260	96.1	125	35%	4.00
	370	350	310	121	151	35%	3.80
	440	410	364	146	153	30%	3.54
490	460	424	163	153	26%	3.53	

NOTES

Cc (cooling capacity)
 Pi (unit power input)
 Hc (heating heat recovery capacity)
 %Hc (percentage heat recovered)
 EER Hc (coefficient of performance during heat recovery = (cooling+ heating capacity) / power input)
 EWC (Entering water heat recovery condenser)
 LWC (Leaving water heat recovery condenser)

Data are referred to:
 SST (compressor saturated suction temperature) = 7°C
 Condenser Inlet Air Temperature = 35°C
 0.0176 m² °C/kW evaporator fouling factor

OPT_1-2-3-4-5_Rev.00_2

8 Options

Partial Heat Recovery pressure drops

	ERAD-E-SS	120	140	170	200	220	250	310	370	440	490
	ERAD-E-SL	120	140	160	190	210	240	300	350	410	460
Heating Capacity (kW)		125	150	171	200	224	263	311	377	393	392
Water Flow (l/s)		5.98	7.15	8.15	9.54	10.71	12.56	14.87	18.01	18.76	18.72
Heat Recovery Pressure Drops (kPa)		33	37	41	44	46	49	29	34	27	23

NOTES

Water flow and pressure drop referred to nominal condition: SST 7°C – condenser air inlet 35°C – water heat recovery in/out 40/45°C

OPT_1-2-3-4-5_Rev.00_3

Partial Heat Recovery pressure drops

	ERAD-E-SS	120	140	170	200	220	250	310	370	440	490
	ERAD-E-SL	120	140	160	190	210	240	300	350	410	460
Heating Capacity (kW)		50.3	60.3	68.6	80	90	105	125	151	153	153
Water Flow (l/s)		2.40	2.88	3.28	3.84	4.31	5.03	5.96	7.22	7.31	7.29
Heat Recovery Pressure Drops (kPa)		6	7	8	8	9	10	6	7	5	4

NOTES

Water flow and pressure drop referred to nominal condition: SST 7°C – condenser air inlet 35°C – water heat recovery in/out 50/60°C

OPT_1-2-3-4-5_Rev.00_4

8 Options

Total and Partial Heat Recovery Pressure Drops

To determinate the pressure drop for different versions or at different working condition, please refer to the following formula:

$$PD_2 \text{ (kPa)} = PD_1 \text{ (kPa)} \times \left(\frac{Q_2 \text{ (l/s)}}{Q_1 \text{ (l/s)}} \right)^{1.80}$$

where:

- PD_2 Pressure drop to be determinate (kPa)
- PD_1 Pressure drop at nominal condition (kPa)
- Q_2 water flow at new working condition (l/s)
- Q_1 water flow at nominal condition (l/s)

How to use the formula: Example

The unit ERAD120E-SS has been selected for working at the following conditions:

- Total heat recovery leaving water temperature 40/50°C
- The heating capacity at these working conditions is: 121 kW
- The water flow at these working conditions is: 2.89 l/s

The unit ERAD120E-SS at nominal working conditions has the following data:

- Total heat recovery leaving water temperature 40/45°C
- condenser air inlet: 35°C
- The heating capacity at these working conditions is: 125 kW
- The water flow at these working conditions is: 5.98 l/s
- The pressure drop at these working conditions is: 33 kPa

The pressure drop at the selected working condition will be:

$$PD_2 \text{ (kPa)} = 33 \text{ (kPa)} \times \left(\frac{2.89 \text{ (l/s)}}{5.98 \text{ (l/s)}} \right)^{1.80}$$

$$PD_2 \text{ (kPa)} = 9 \text{ (kPa)}$$

OPT_1-2-3-4-5_Rev.00_5

9 Dimensions

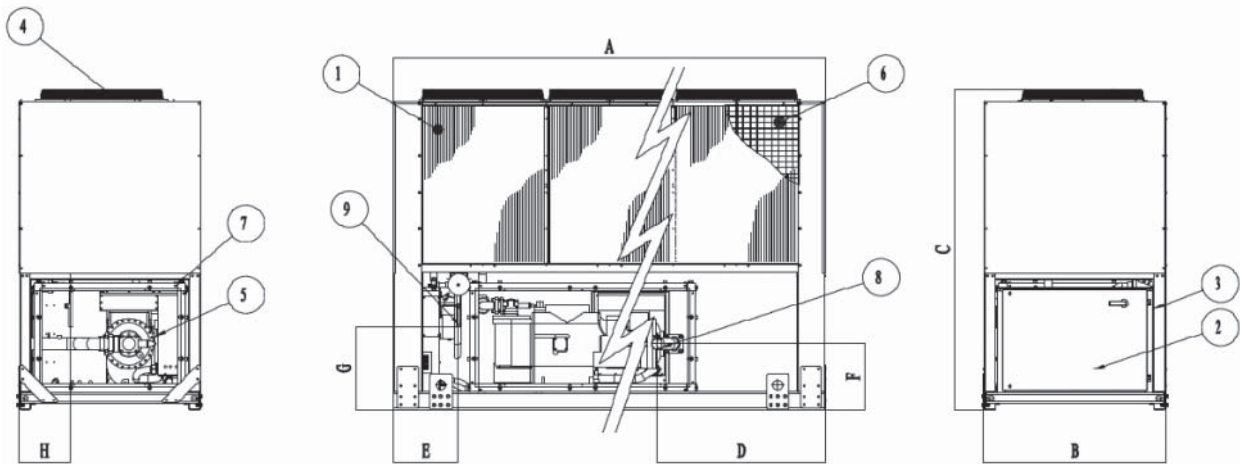

Size		Dimensions								
E-SS	E-SL	A	B	C	D	E	F	G	H	Fans
120	120	2165	1292	2273	298	460	466	587	366	2
140	140	2165	1292	2273	298	460	466	587	366	2
170	160	3065	1292	2273	1198	460	466	587	366	3
200	190	3065	1292	2273	1198	460	466	587	366	3
220	210	3965	1292	2273	2098	460	466	587	416	4
250	240	3965	1292	2273	2098	460	466	587	416	4

LEGEND

- 1 - Air heat exchanger (condenser)
- 2 - Electrical control panel
- 3 - Slot for power and control connection
- 4 - Fan
- 5 - Compressor
- 6 - Coil protection guards (optional)
- 7 - Compressor sound enclosure (optional)
- 8 - Suction welding connection
- 9 - Liquid line brazing connection

9 Dimensions

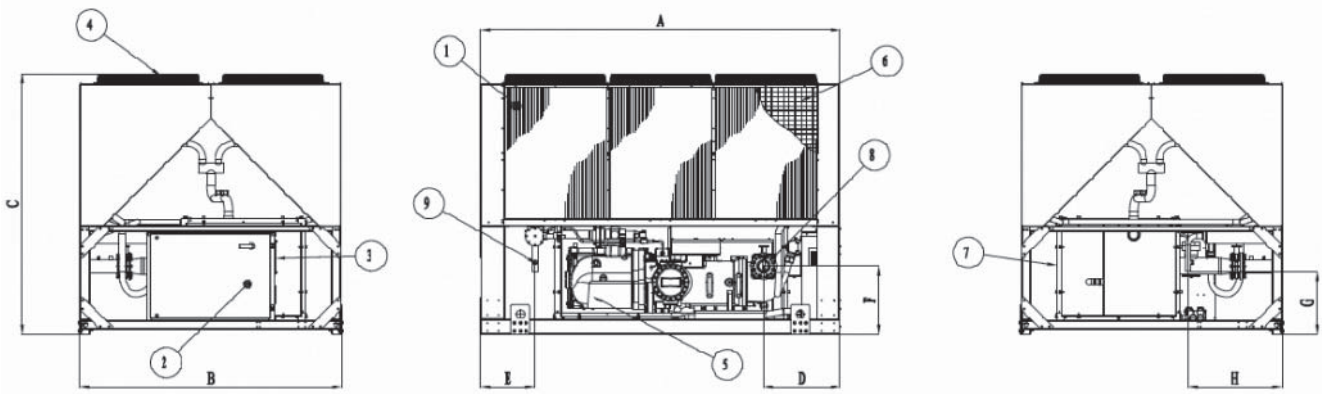

Size		Dimensions								
E-SS	E-SL	A	B	C	D	E	F	G	H	Fans
310	300	3070	2236	2223	652	465	581	537	800	6
370	350	3070	2236	2223	652	465	581	537	800	6
440	410	3070	2236	2223	652	465	581	537	800	6
490	460	3070	2236	2223	652	465	581	537	800	6

LEGEND

- 1 - Air heat exchanger (condenser)
- 2 - Electrical control panel
- 3 - Slot for power and control connection
- 4 - Fan
- 5 - Compressor
- 6 - Coil protection guards (optional)
- 7 - Compressor sound enclosure (optional)
- 8 - Suction welding connection
- 9 - Liquid line brazing connection

10 Installation notes

Warning

Installation and maintenance of the unit must be performed only by qualified personnel who has knowledge with local codes and regulations, and experience with this type of equipment. The unit must be installed to allow all the maintenance operations.

Handling

Care should be taken to avoid rough handling or shock due to dropping of the unit. Do not push or pull the unit from anything other than the base frame. Never allow the unit to fall during unloading or moving as this may result in serious damage. To lift the unit, rings are provided in the base frame of the unit. Spreader bar and cables should be arranged to prevent damage to the condenser coil or unit cabinet.

Location

The units are produced for outside installation on roofs, floors or below ground level on condition that the area is free from obstacles for the passage of the condenser air. The unit should be positioned on solid foundations and perfectly level; in the case of installation on roofs or floors, it may be advisable to arrange the use of suitable weight distribution beams. When the units are installed on the ground, a concrete base at least 250 mm wider and longer than the unit's footprint should be laid. Furthermore, this base should withstand the unit weight mentioned in the technical data table.

Space requirements

The units are air-cooled, then it is important to respect the minimum distances which guarantee the best ventilation of the condenser coils. Limitations of space reducing the air flow could cause significant reductions in cooling capacity and an increase in electricity consumption.

To determinate unit placement, careful consideration must be given to assure a sufficient air flow across the condenser heat transfer surface. Two conditions must be avoided to achieve the best performance: warm air recirculation and coil starvation. Both these conditions cause an increase of condensing pressures that result in reductions in unit efficiency and capacity.

Moreover the unique microprocessor has the ability to analyse the operating environment of the air cooled condensing unit and to optimize its performance to stay on-line during abnormal conditions.

Each side of the unit must be accessible after installation for periodic service. Fig.1 and 2 show you minimum recommended clearance requirements.

Vertical condenser air discharge must be unobstructed because the unit would have its capacity and efficiency significantly reduced.

If the units are positioned in places surrounded by walls or obstacles of the same height as the units, the units should be at least 2500 mm from obstacles (Fig.3 and 4). In the event the obstacles are higher than the units, the units should be at least 3000 mm from the obstacle (Fig.5 and 6). Units installed closer than the minimum recommended distance to a wall or other vertical riser may experience a combination of coil starvation and warm air recirculation, thus causing reduction in unit capacity and efficiency reductions. The microprocessor control is proactive in response "of design condition". In the case of single or compounded influences restricting airflow to the unit, the microprocessor will act to keep the compressor running (at reduced capacity) rather than allowing a shut-off on high discharge pressure.

When two or more units are positioned side by side it is recommended that the condenser coils are at least 3600 mm distance from one another (Fig.7 and 8); strong wind could be the cause of air warm recirculation.

For other installation solutions, consult our technicians.

10 Installation notes

The above recommended information are representative for general installation. A specific evaluation should be done by contractor depending on the case.

Minimum recommended installation clearances.

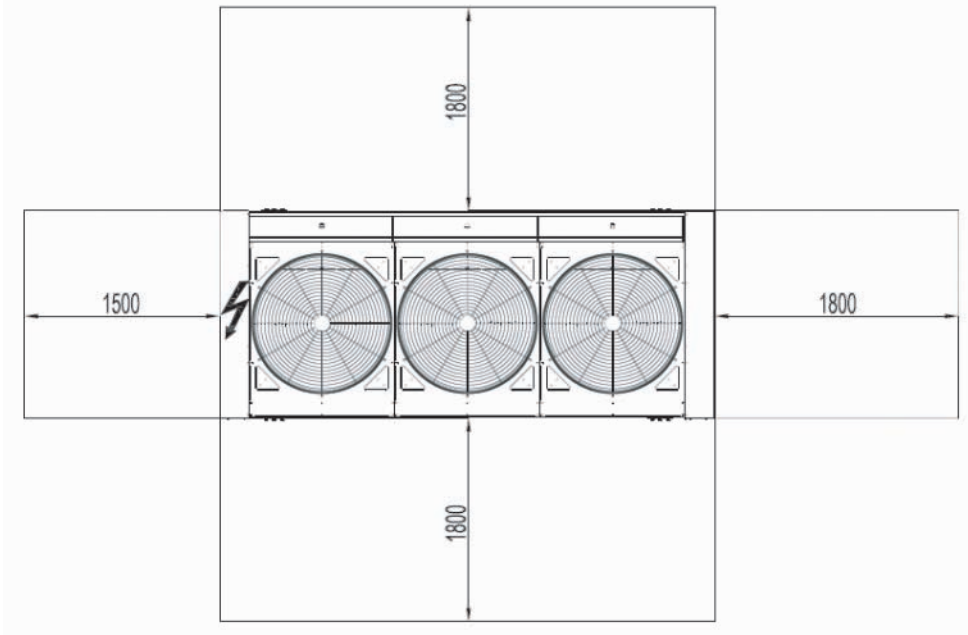

Fig. 1

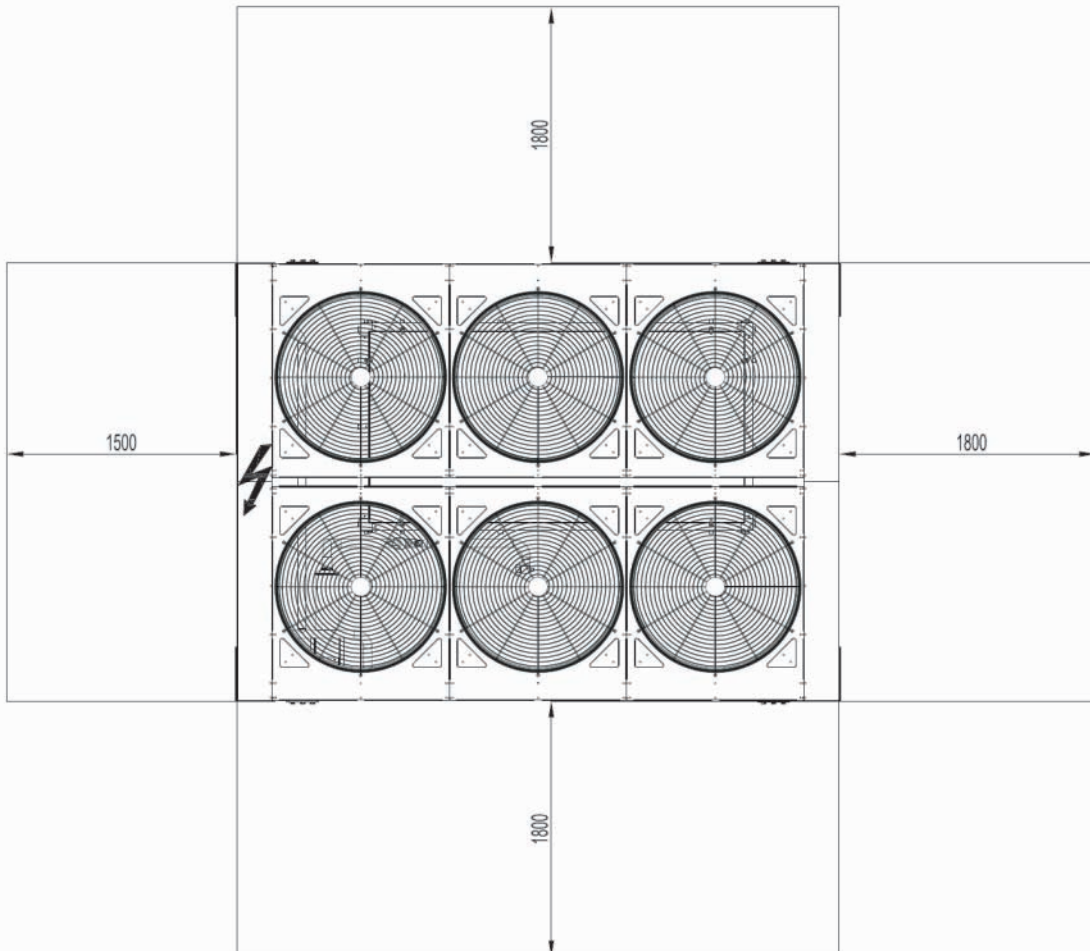

Fig. 2

10 Installation notes

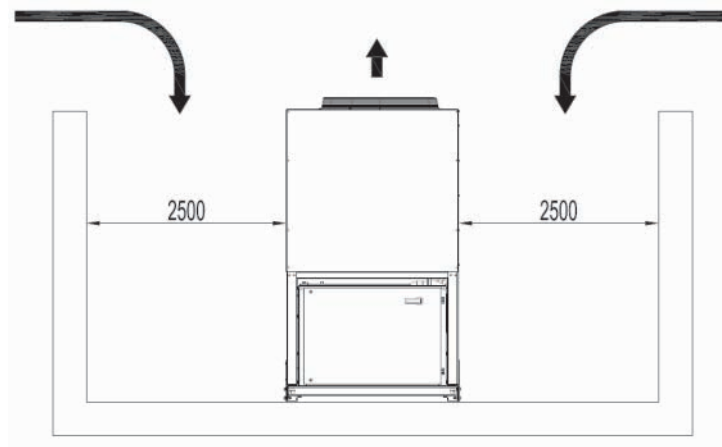

Fig. 3

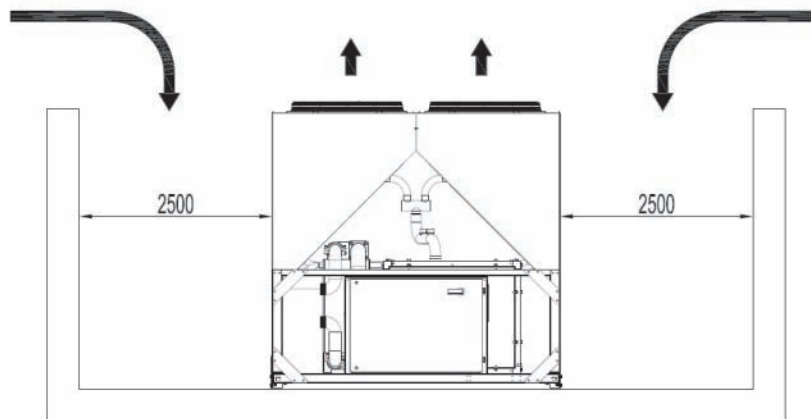

Fig. 4

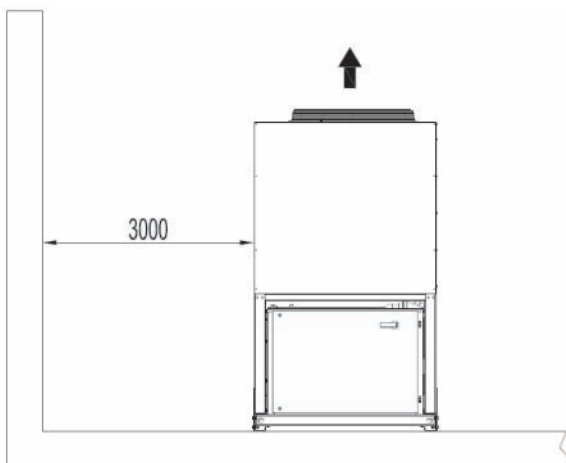

Fig. 5

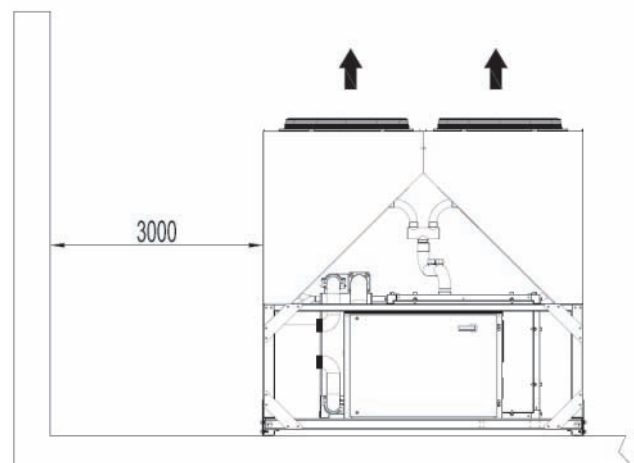

Fig. 6

10 Installation notes

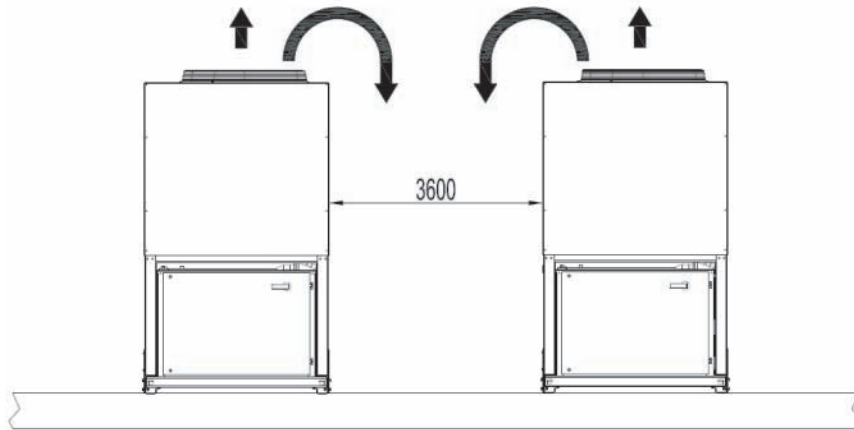

Fig. 7

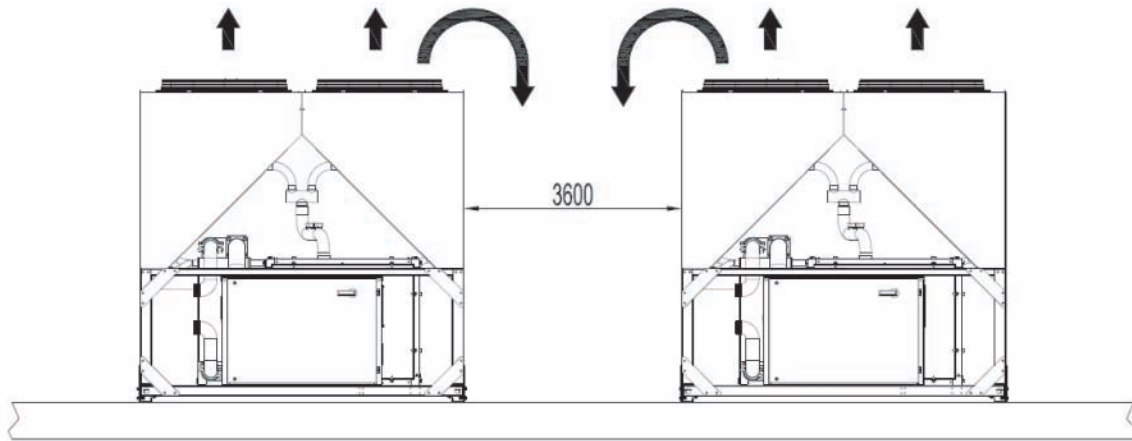

Fig. 8

Acoustic protection

When sound level must meet special requirements, it is necessary to pay the maximum attention to ensure the perfect insulation of the unit from the support base by applying appropriate vibration-dampening devices on the unit, on the refrigerant pipes and on the electrical connections.

Storage

The environment conditions have to be in the following limits:

Minimum ambient temperature:	-20°C
Maximum ambient temperature:	+57°C
Maximum R.H.:	95% not condensing

11 Specification

Technical Specification for Air Cooled Condensing Unit

GENERAL

The air cooled screw condensing unit will be designed and manufactured in accordance with following European directives:

Construction of pressure vessel	97/23/EC (PED)
Machinery Directive	2006/42/EC
Low Voltage	2006/95/EC
Electromagnetic Compatibility	2004/108/EC
Electrical & Safety codes	EN 60204-1 / EN 60335-2-40
Manufacturing Quality Stds	UNI – EN ISO 9001:2004

Before shipment a full test will be held to avoid any losses.

Condensing unit will be delivered to the job site completely assembled and charged with holding charge nitrogen 0.5 bar and with right oil quantity.

Comply with the manufacturer instructions for rigging and handling equipment.

The unit will be able to start up and operate as standard at full load and outside air temperature from °C to °C with an evaporator leaving fluid temperature between °C and °C

REFRIGERANT

Only R-134a will be accepted.

PERFORMANCE

- ✓ Number of air cooled screw condensing unit:
- ✓ Cooling capacity for single air cooled screw condensing unit: kW
- ✓ Power input for single air cooled screw condensing unit in cooling mode: kW
- ✓ Nominal outside working ambient temperature in cooling mode: °C
- ✓ Operating voltage range should be 400V ±10%, 3ph, 50Hz, voltage unbalance maximum 3%, without neutral conductor and shall only have one power connection point.

UNIT DESCRIPTION

Condensing unit shall include as standard: one refrigerant circuit, semi-hermetic type rotary single screw compressor, air-cooled condenser section, R134a refrigerant, lubrication system, motor starting components, discharge line shut-off valve, suction line shut-off valve, control system and all components necessary for safe and stable unit operation.

Condensing unit will be factory assembled on a robust base-frame made of galvanized steel, protected by an epoxy paint.

SOUND LEVEL AND VIBRATIONS

Sound pressure level at 1 meter distance in free field, semispheric conditions, shall not exceeddB(A). The sound pressure levels must be rated in accordance to ISO 3744.

Other types of rating unacceptable. Vibration on the base frame should not exceed 2 mm/s.

11 Specification

DIMENSIONS

Unit dimensions shall not exceed following indications:

- ✓ unit length mm,
- ✓ unit width mm,
- ✓ unit height mm.

CONDENSING UNIT COMPONENTS

Compressors

From size ERAD120E-SS to size ERAD250E-SS and from size ERAD120E-SL to size ERAD240E-SL

- ✓ Semi-hermetic, single-screw type with one main helical rotor meshing with gaterotor. The gaterotor will be constructed of a carbon impregnated engineered composite material. The gaterotor supports will be constructed of cast iron.

From size ERAD310E-SS to size ERAD 490E-SS and from size ERAD300E-SL to size ERAD460E-SL

- ✓ Semi-hermetic, single-screw asymmetric type with one main helical rotor meshing with two diametrical opposed gaterotors. The gaterotors' contact elements shall be constructed of composite material designed for extended life. Electrical motor shall be 2-pole, semi-hermetic, squirrel-cage induction type and cooled by suction gas.
- ✓ The oil injection shall be used in order to get high EER (Energy Efficiency Ratio) also at high condensing pressure and low sound pressure levels in each load condition.
- ✓ The compressor shall be provided with a built in, high efficiency, mesh type oil separator and oil filter.
- ✓ Refrigerant system differential pressure shall provide oil injection on all moving compressor parts to correctly lubricate them. Electrical oil pump lubricating system is not acceptable.
- ✓ Compressor cooling must be done by refrigerant liquid injection. External dedicated heat exchanger and additional piping to carry the oil from the compressor to heat exchanger and viceversa will be not accepted.
- ✓ The compressor shall be direct electrical driven, without gear transmission between the screw and the electrical motor.
- ✓ The compressor casing shall be provided with ports to realize economized refrigerant cycles.
- ✓ Compressor must be protected by temperature sensor for high discharge temperature and electrical motor thermistor for high winding temperature.
- ✓ The compressor shall be equipped with an electric oil heater.
- ✓ Compressor shall be fully field serviceable. Compressor that must be removed and returned to the factory for service shall be unacceptable.

Cooling capacity control system

- ✓ Each condensing unit will have a microprocessor for the control of compressor slide valve position.
- ✓ The unit capacity control shall be infinitely modulating, from 100% down to 25%. The condensing unit shall be capable of stable operation to a minimum of 25% of full load without hot gas bypass.
- ✓ The system shall control the unit based on the leaving evaporator liquid or air temperature that shall be controlled by a PID (Proportional Integral Derivative) logic.
- ✓ Unit control logic shall manage the compressor slides to exactly match plant load request in order to keep constant the set point for delivered chilled liquid or air temperature.
- ✓ The microprocessor unit control shall detect conditions that approach protective limits and take self-corrective action prior to an alarm occurring. The system shall automatically reduce condensing unit capacity when any of the following parameters are outside their normal operating range:
 - o High condenser pressure
 - o Low evaporation refrigerant temperature

11 Specification

Condenser coil

- ✓ The condenser coils are constructed with internally finned seamless copper tubes and arranged in a staggered row pattern and mechanically expanded into lanced and rippled aluminium fins with full fin collars for higher efficiencies. The space between the fins is given by a collar that will increase the surface area in connection with the tubes, protecting them from ambient corrosion.
- ✓ The coils will have an integral subcooler circuit that provides sufficient subcooling to effectively eliminate the possibility of liquid flashing and increase the unit's efficiency of 5-7% without increasing in energy consumption.
- ✓ The condenser coil shall be leak-tested and submitted to a pressure test with dry air.

Condenser fans

- ✓ The fans used in conjunction with the condenser coils, shall be propeller type with glass reinforced resin blades for higher efficiencies and lower noise. Each fan shall be protected by a fan guard.
- ✓ The air discharge shall be vertical and each fan must be coupled to the electrical motor, supplied as standard to IP54 and capable to work to ambient temperatures of - 20°C to + 65°C.
- ✓ They shall have as a standard a thermally protection by internal thermal motor protection and protected by circuit breaker installed inside the electrical panel as a standard.

Refrigerant circuit

- ✓ The circuit shall include as standard: compressor discharge shut-off valve, suction shut-off valve, replaceable core filter-drier, sight glass with moisture indicator and insulated suction line.

Condensation control

- ✓ The units will be provided with an automatic control for condensing pressure which ensures the working at low external temperatures down to - °C, to maintain condensing pressure.
- ✓ Compressor automatically unloads when abnormal high condensing pressure is detected to prevent the shutdown of the refrigerant circuit (shutdown of the unit) due to a high-pressure fault.

Low Sound unit version (on request)

- ✓ The unit compressor shall be connected with unit's metal baseframe by rubber antivibration supports to prevent the transmission of vibrations to all metal unit structure and so to control the unit sound.
- ✓ The condensing unit shall be provided with an acoustically compressor enclosure. This enclosure shall be realized with a light, corrosion resisting aluminium structure and metal panels. The compressor sound-proof enclosure shall be internally fitted with flexible, multi layer, high density materials.

11 Specification

Control panel

- ✓ Field power connection, control interlock terminals, and unit control system should be centrally located in an electric panel (IP 54). Power and starting controls should be separate from safety and operating controls in different compartments of the same panel.
- ✓ Compressor starting will be Wye-Delta type (Y-Δ).
- ✓ Operating and safety controls should include energy saving control; emergency stop switch; overload protection for compressor motor; high and low pressure cut-out switch (for each refrigerant circuit); anti-freeze thermostat; cut-out switch for the compressor.
- ✓ All of the information regarding the unit will be reported on a display and with the internal built-in calendar and clock that will switch the unit ON/OFF during day time all year long.
- ✓ The following features and functions shall be included:
 - leaving liquid or air temperature reset by controlling the liquid or air temperature Δt , by a remote 4-20mA DC signal or by controlling the external ambient temperature;
 - soft load function to prevent the system from operating at full load during the chilled fluid pulldown period;
 - password protection of critical parameters of control;
 - start-to-start and stop-to-start timers to provide minimum compressor off-time with maximum motor protection;
 - communication capability with a PC or remote monitoring;
 - discharge pressure control through intelligent cycling of condenser fans;
 - lead-lag selection by manual or automatically by circuit run hours;
 - double set point;
 - scheduling via internal time clock to allow programming of a yearly start-stop schedule accommodating weekends and holidays.

Optional High Level Communications Interface

Condensing unit must be able to communicate to BMS (Building Management System) based on the most common protocols as:

- ModbusRTU
- LonWorks, now also based on the international 8040 Standard Condensing unit Profile and LonMark Technology
- BacNet BTP certified over IP and MS/TP (class 4) (Native)
- Ethernet TCP/IP.

For more information email info@daikinapplied.uk or visit www.daikinapplied.uk

For all Daikin Applied UK,
Daikin Applied Service &
Spares enquiries call us on:
0345 565 2700



Daikin Europe N.V. participates in the Eurovent Certified Performance programme for Liquid Chilling Packages and Hydronic Heat Pumps, Fan Coil Units and Variable Refrigerant Flow systems. Check ongoing validity of certificate: www.eurovent-certification.com

The present publication is drawn up by way of information only and does not constitute an offer binding upon Daikin Europe N.V. Daikin Europe N.V. has compiled the content of this publication to the best of its knowledge. No express or implied warranty is given for the completeness, accuracy, reliability or fitness for particular purpose of its content and the products and services presented therein. Specifications are subject to change without prior notice. Daikin Europe N.V. explicitly rejects any liability for any direct or indirect damage, in the broadest sense, arising from or related to the use and/or interpretation of this publication. All content is copyrighted by Daikin Europe N.V.

