

DWSC

VINTAGE C

Water cooled
centrifugal chillers

Product manual

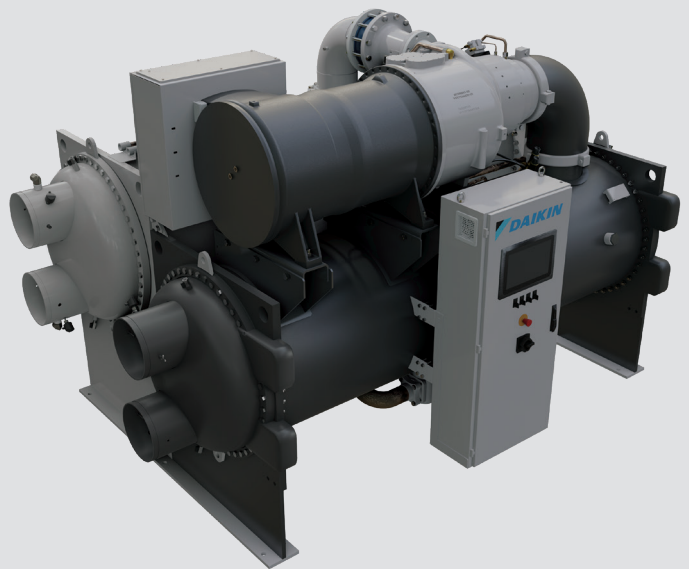

Nominal capacity range with R-134a/R513A: 1050 - 4500 kW (300 - 1250 RT)

Nominal capacity range with R-1234ze: 790 - 3350 kW (225 - 950 RT)

Designed for a wide range of applications

Single and dual compressor chiller options

Refrigerant: R-134a / R-513A / R-1234ze

CODE	DWSC DWDC Vintage C.
Date	2021
Supersedes	DWSC/DWDC Vintage B

CONTENTS

FEATURES AND BENEFITS

GENERAL CHARACTERISTICS

NOMENCLATURE

OPTIONS AND ACCESSORIES

PHISICAL DATA AND WEIGHTS

ELECTRICAL DATA

APPLICATIONS CONSIDERATIONS

INSTALLATION NOTES

TECHNICAL SPECIFICATIONS

FEATURES AND BENEFITS

Excellent Performance

Daikin offers a wide range of centrifugal vessels and component combinations to provide the right solution for your specific application. The single compressor DWSC offers excellent full load performance and outstanding part-load efficiency if equipped with Variable Speed Drive, for which Daikin has introduced a brand new and enhanced solution with this latest product series. Contact your Daikin representative for detailed information to decide which model is right for your job requirements.

Positive Pressure Design

Positive pressure systems offer numerous advantages over negative pressure design. In a negative pressure system, leaks allow air, moisture, and other contaminants to seep into the system, which will gradually decrease performance, as well as cause corrosion which must be removed. The Daikin positive pressure design eliminates this worry, providing sustainable performance and trouble-free ownership for the life of the unit under normal operation.

Gear Driven Advantage

Daikin's precision-engineered gear driven design allows for lighter components, less vibration, and ability to select gear ratios that will provide the optimum impeller speed for your application. Older direct-drive designs must use large, heavy impellers to reach similar tip speeds, which cause more vibration and greater stress on shaft and motor during unexpected electrical interruptions. The compact design and lighter weight components allow for efficient hydrodynamic bearings to be used. This means that during operation, the shaft is supported on a film of lubricant, with no shaft-to-bearing contact, providing theoretical infinite life bearings under normal circumstances. The design simplicity of the Daikin centrifugal compressors provides increased durability and reliable performance.

Low GWP Refrigerant

The use of R-1234ze(E) offers an environmentally friendly solution, combining a low Global Warming Potential (GWP) with high energy efficiency. R-1234ze(E) is an HFO refrigerant (Hydro Fluoro Olefins) with an Ozone Depletion Potential (ODP) is equal to zero (0).

The introduction of the new R-1234ze(E) range provides a long-term solution that supports the HFC phase down schedule of the F-gas Regulation.

Alongside R-1234ze(E), Daikin can offer products with conventional refrigerant R-134a or R-513A (which have lower environmental impact than R-134a), according to customer needs.

Unmatched Unloading

Daikin pioneered the use of moveable discharge geometry to lower the surge point of centrifugal compressors. The point at which the compressor enters a stall or surge condition generally limits compressor unloading. Chillers with a fixed discharge will experience stall or surge at low loads due to refrigerant re-entering the impeller. When in a stall condition, the refrigerant gas is unable to enter the volute due to its low velocity and remains stalled in the impeller. In a surge condition the gas rapidly reverses direction in the impeller causing excessive vibration and heat. Daikin compressors reduce the discharge area as load decreases to maintain gas velocity and greatly reduce the tendency to stall or surge.

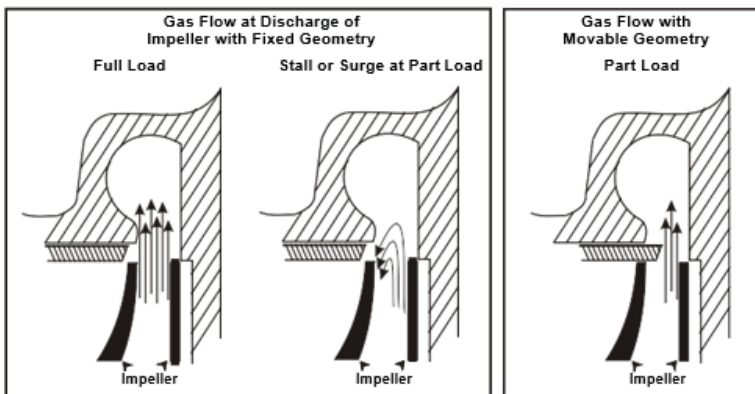

Figure 1: Fixed vs. Moveable Discharge Geometry

In Figure 1, the drawing on the left shows a cross-section view of the operation at full load of a unit with a fixed compressor discharge. At full load, a large quantity of gas is discharged with a fairly uniform discharge velocity as indicated by the arrows. The center drawing shows a fixed compressor discharge at reduced capacity. Note that the velocity is not uniform and the refrigerant tends to reenter the impeller. This is caused by low velocity in the discharge area and the high pressure in the condenser, resulting in unstable surge operation and with noise and vibration generated.

Figure 2 shows the unique Daikin moveable discharge geometry. As the capacity reduces, the movable unloader piston travels inward, reducing the discharge cross section area and maintaining the refrigerant velocity. This mechanism allows our excellent unloading capacity reduction.



Figure 2: Moveable diffuser closes impeller discharge area as load decreases

Trouble-Free Startup

All Daikin chillers are factory tested on AHRI qualified computer-controlled test stands. Operating controls are checked and adjusted, and the refrigerant charge is adjusted for optimum operation and recorded on the unit nameplate. Units operating with 50-Hz power are tested with a 50-Hz power supply. The testing helps ensure correct operation prior to shipment, and allows factory calibration of chiller operating controls.

All domestic Daikin centrifugal chillers are commissioned by your service representative for Daikin Applied, or by authorized and experienced Daikin Applied startup technicians.

This procedure helps ensure that proper starting and checkout procedures are employed and helps in a speedy commissioning process, giving you confidence that your chiller is operating as expected.

Lubrication System

A separately driven electric oil pump assembly supplies lubrication at controlled temperature and pressure to all bearing surfaces and is the source of hydraulic pressure for the capacity control system.

The control system will not allow the compressor to start until oil pressure, at the proper temperature, is established. It also allows the oil pump to operate after compressor shutdown to provide lubrication during coast-down. Lubricant from the pump is supplied to the compressor through a water-cooled, brazed-plate heat exchanger and single or dual five-micron oil filters internal to the compressor. All bearing surfaces are pressure lubricated. Drive gears operate in a controlled lubricant mist atmosphere that efficiently cools and lubricates them.

Lubricant is made available under pressure from the compressor oil filter to the unit capacity control system and is used to position the inlet guide vanes in response to changes in leaving chiller water temperature.

If a power failure occurs, an emergency oil reservoir provides adequate lubrication flow under pressure, and prevents damage that could occur during the coast-down period with the oil pump stopped.

Since Daikin chillers are positive pressure, there is no need to change the lubricant or filter on a regular basis. As with any equipment of this type, an annual oil check is recommended to evaluate the lubricant condition.

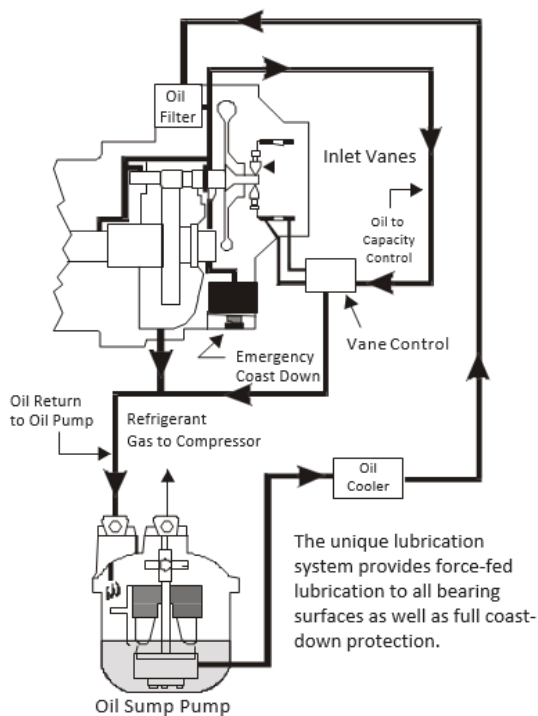

Figure 3: Lubrication System Schematic

Enhanced Surge Protection

When centrifugal compressors operate at part load, the volume of refrigerant gas entering the impeller is reduced. At the reduced flow, the impeller's capacity to develop the peak load head is also reduced. At conditions of low refrigerant flow and high compressor head (pressure difference), stall and/or surge can occur (a stall is gas static in the impeller, a surge condition is gas rapidly reversing direction through the impeller). A number of things can contribute to this condition including inadequate maintenance of condenser tube cleanliness, a cooling tower or control malfunction, or unusual ambient temperatures among others.

For these abnormal conditions, Daikin compressor designers have developed a protective control system that senses the potential for a surge, looks at the entire chiller system operation and takes corrective action if possible; or stops the compressor, to help prevent any damage from occurring. This protection, called ESP, is provided as standard on all Daikin centrifugal compressors.

Quiet Operation

Daikin centrifugal chillers have two unique features to limit sound generation. One is the unique liquid injection system and the other is that Daikin chillers get quieter as they unload.

Liquid Injection

A small amount of liquid refrigerant is taken from the condenser and injected into the compressor discharge area. The liquid droplets absorb sound energy and reduce the compressor's overall sound level. The droplets evaporate and reduce discharge superheat.

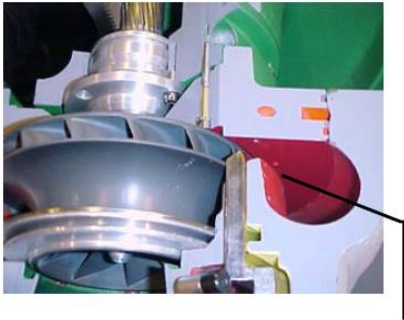

Radial ports inject liquid refrigerant into the discharge gas as it enters the volute.

Quieter as Chiller Unloads

Many centrifugal compressors become louder as they unload. Daikin design results in a reduction in sound levels at lower loads, where most chillers spend most of their operating hours.

Refrigerant Storage Capability - Standard

The condensers on DWSC chillers are sized to hold the entire chiller refrigerant charge and are provided with the necessary valves to isolate this charge. This feature eliminates the need for separate storage vessels in most applications.

Motor Cooling

Compressor construction and chiller layout in DWSC range are avoiding contamination of a motor burnout on the refrigerant circuit. The compressor motor is isolated from the main refrigerant flow circuit so that any contaminants generated by a motor failure will not pass into the main refrigerant circuit. Moisture, acid and/or carbon particles will be automatically trapped within the compressor's dedicated coolant feed and exit lines.

Internally, the compressor motor compartment is separated and sealed from the main refrigerant compression chamber. A double shaft seal on the motor side of the gear housing prevents cross flow of refrigerant along the motor shaft. The motor coolant feed line is equipped with both a solenoid valve and a check valve. These mechanical components, plus the higher pressure of the liquid refrigerant, prevent back feed into the main refrigerant system. Refrigerant vapor exiting the motor compartment must pass through a high pressure drop filter-drier, sized to immediately plug up and seal off the motor compartment. Both the coolant feed and return lines are equipped with manual shutoff valves to permit component service.

Over 30 years of field experience have proven the reliability of these compressor motors. Despite the reliability inherent in the motor design and the protective control, electrical distribution system faults and lightning strikes can occur that are beyond the control of the most conscientious designer. The coolant protective system protects the unit charge from being contaminated.

Codes and Certifications

DWSC C Series is CE marked, complying with European directive in force concerning manufacturing and safety.

Units are designed and manufactured in accordance with applicable selections of the following:

- Pressure Equipment Directive 2014/68/EU:
- Machinery Directive 2006/42/EC
- Low Voltage Directive 2014/35/EU
- Electromagnetic Compatibility 2014/30/EU
- Electrical & Safety codes EN60204-1/EN61439-1/EN61439-2
- EN378
- DIRECTIVE 2009/125/EC (ECODESIGN)
- AHRI Standard 550/590 for Water-Chilling and Heat Pump Water-Heating Packages Using the Vapor Compression Cycle
- Manufacturing Quality Standards UNI EN ISO 9001:2004
- Environmental Management System UNI EN ISO 14001:2004
- Health & Safety Management System BS OHSAS 18001:2007

On request units can be produced complying with laws in force in non European countries (ASME, EAC, etc.), and with other applications, such as Marine rules (DNVGL, Bureau Veritas Marine, Lloyd's Register, RINA, etc.).

GENERAL CHARACTERISTICS

Product line up is made by single compressor models.

Nominal capacity range with R-134a/R-513A: 1050 - 4500 kW (300 – 1250 RT) (AHRI conditions)

Nominal capacity range with R-1234ze: 790 - 3350 kW (225 – 950 RT) (AHRI conditions)



Example of unit layout – DWSC100M unit in frontal view



Example of unit layout – DWSC100M unit in rear view

Structure

Color is Ivory White (Munsell code 5Y7.5/1, ± RAL7044). Unit is fitted with eyehook for lifting with ropes and for an easy handling. The weight is uniformly distributed along the base's profiles for a simplified unit installation.

Vibration Mounting

Every Daikin chiller is run tested and compressor vibration is measured and limited to a maximum rate of 0.14 inches per second, which is considerably more stringent than other available compressors. Consequently, floor-mounted spring isolators are not usually required. Rubber mounting pads are shipped with each unit. It is wise to continue to use piping flexible connectors to reduce sound transmitted into the pipe and to allow for expansion and contraction.

Daikin Single Stage Centrifugal Compressor

The DWSC C series is equipped with Daikin design Single Stage Centrifugal Compressor. This technology is enjoying highly balanced loads resulting in reduced mechanical stress for the main components. Lifetime and reliability are in this way improved and, at the same time, vibrations and noise emissions are reduced.

Gear-Drive Offers Greater Operating Efficiency Than Direct Drive

Centrifugal compressor efficiency is a function of impeller design and application to the refrigeration system. The increased heat transfer surface and efficiency of modern heat exchangers have changed compressor head and impeller tip speed requirements. Direct-drive designs limit the manufacturer's ability, within a single compressor size, to select impellers at or near peak impeller efficiency. While a unit selected at poor impeller efficiency might produce the required performance at peak load, its operating characteristics over the entire range of part load performance are sharply curtailed, resulting in increased annual operating costs.

Daikin gear-drive centrifugal chillers provide a variety of tip speed ratios to permit selection of impellers for maximum efficiency over their entire part load to full load range and are also ideal for 50 Hz application. Mechanical gear losses are limited by design standards to less than one-half of 1%. The impeller efficiency obtained by alternate gear selections can increase chiller efficiency by as much as 7%.

As energy costs continue to rise, the economic advantages of gear drive to obtain maximum efficiencies will be even more advantageous. The efficiency of either direct-drive or gear-drive compressor can be improved through the use of variable frequency drives to reduce compressor speed at low load/low head conditions.

Extended Motor Life

Daikin's modern compact compressor design provides many operating advantages that improve its overall reliability and durability. One such advantage is prolonged motor life. A motor draws locked rotor current until it reaches break-away torque at approximately 80% of its running speed.

While drawing locked rotor current, the stresses on the motor are over six times that of full load. The Daikin compressors absolutely minimize this stress through the unique gear drive and light weight drive train that allows a 1750 kW (500RT) compressor to reach running speed in less than three seconds. The owner benefits from a longer motor life.

Quiet, stable capacity from 10% to 100% without hot gas bypass

Compressor capacity on Daikin chillers is maximized at full load and modulated to 10% load by interlocked inlet guide vanes and the movable discharge geometry. This Daikin design innovation has real owner benefits. Most centrifugal compressors do not unload this well and waste energy at low load conditions by unnecessary compressor cycling or by the use of inefficient hot gas bypass.

No leakage at the capacity control mechanism

An oil pressure operated, guide vane activating piston is internally mounted and powered, eliminating leakage from external linkage and seals. The vanes are positioned in response to variation in leaving chiller water temperature. A built-in compensating control allows automatic override of normal operation to close the vanes for low suction pressure or current limiting duty.

Single Stage Simplicity = Savings

Compressor efficiency is not a function of multiple impellers. Maintenance of optimum efficiency at peak and, more importantly, at part load, is a function of the total compressor and chiller design including:

- Motor efficiency
- Refrigerant type
- Condenser and evaporator surfaces
- Compressor mechanical friction
- Impeller and vane design
- Refrigerant flow passages

Of these, the least considered performance factor on actual versus theoretical performance is the refrigerant flow passages between the discharge of one impeller and the inlet to the next impeller on multi-stage machine design. The energy loss in a single passage will be greater or equal to the loss in the suction passage between the evaporator outlet and the first stage impeller inlet, depending upon the compactness of the total compressor design. Single stage impeller design can eliminate that additional loss, and provides an opportunity for maximum system efficiency.

The primary advantage to multi-stage centrifugal operation, in the pressure and volume ranges characteristic of typical air conditioning systems, is the expansion of impeller head coefficients at reduced volumetric flows or cooling loads. The Daikin backward inclined single stage impeller, combined with unique movable diffuser geometry at the impeller discharge, provides a stable operating range superior to multi-stage systems. Thus, selection of Daikin chillers permits operation from 100% to 10% capacity (to 5% on DWDC dual compressor chillers) without surging and at maximum efficiency, i.e. no hot gas bypass.

Optimum compressor efficiency is designed into each Daikin impeller. The Daikin designed impeller not only minimizes pressure loss at the inlet and maximizes compression efficiency, but also breaks up pure tone sound to operate at competitively low sound power levels. A simple short diffuser and a volute design passing compressed gas directly into the condenser maintain the compressor efficiency.

Bearings

Since the impeller shaft must be sized to support the static, rotational and torsional loads applied by the impeller, as impellers become larger, shafts must also become proportionally larger. These factors also come into play in the design or selection of a bearing. The primary criteria used in bearing design are:

1. The load-per-unit of bearing area.
2. The relative velocity of the two bearing surfaces.
3. The bearing dimensions.
4. The viscosity of the lubricating oil.

Notice that item 2 returns to the phenomenon of tip speed. Surface velocity is simply the tip speed of the inner bearing surface or shaft with respect to the outer bearing surface as illustrated in the following diagram.

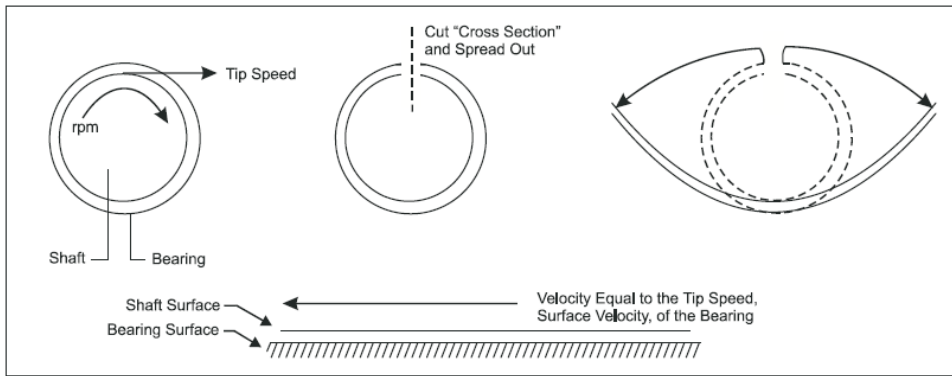

Figure Bearing loading

A hydrodynamic bearing is basically two infinite surfaces passing over one another with a velocity equal to the surface velocity. Bearing design, and consequently bearing life, is determined largely by the above criteria. Rpm, by itself as an absolute, is only one half of the equation in the design process. One can also see that higher rpm and smaller, lighter parts actually reduce the load and wear on bearings.

It is the surface velocity in conjunction with the load to be supported that determines bearing life and therefore bearing selection. Referring to the analogy of the tractor trailer versus the utility trailer, one sees that even though the utility trailer tires operate at a much higher rpm, the tractor trailer wheel bearings must be much more massive due to the much heavier dynamic loading.

Shaft rotating speed has little effect on bearing wear.

The smaller rotating mass of a machine will improve the life of the bearing. Before the shaft begins to spin, it rests on the bearing surface. Once the shaft starts rotating, an oil film develops between the shaft and the bearing that supports the shaft. The low mass of a positive pressure machine not only exerts a smaller static load on the bearings, but the fast spin-up enabled by the low inertia of the modern gear drive compressor permits the supportive oil film to build up more quickly.

Refrigerant

The DWSC C series is designed for R-134a/R-513A/R-1234ze refrigerants in order to achieve the highest possible unit efficiency with every refrigerant.

Heat Exchangers

Daikin packaged centrifugal chillers are equipped with new high performance heat exchangers.

The unique design greatly increases heat transfer and reduces unit footprint and refrigerant charge compared to previous designs. Vessel length has been reduced by 16 percent if compare to previous Vintage B.

Chillers are designed, constructed and tested in accordance with PED CE-marked. On request units can be produced complying with laws in force in non European countries (ASME, EAC, etc.), and with other applications, such as Marine rules (DNVGL, Bureau Veritas Marine, Lloyd's Register, RINA, etc.).

The replaceable water tubes are internally rifled and externally enhanced copper and are mechanically bonded to steel tube sheets. Standard tubes are 0.635mm (0.025-inch) wall thickness. Optional tubes include 0.0711mm (0.028 inch) and 0.889mm (0.035-inch) wall thickness on either vessels and 90/10 cupro-nickel, 304 stainless steel or titanium material. Clad tube sheets and epoxy-coated heads can be provided. Optional tubes have impact on unit lead time.

Vessels are available for 1, 2 or 3-pass water flow. A 20mm (¾-inch) flexible foam insulation is a factory installed standard option. 1½-inch thick is available as option on request. See following chapter OPTIONS AND ACCESSORIES. With either of these options, all seams are glued to form an effective vapor barrier and the entire chiller barrel, including non-connection heads and tube sheets, compressor suction line, and motor barrel, are insulated. Detailed information on the insulation can be found in next chapter Physical Data and Weights.

Electronic expansion valve

There are three refrigerant control devices used in the industry, expansion valves (thermostatic or electronic), fixed orifices, and float systems. Of the three, electronic expansion valve offers superior refrigerant management throughout the entire chiller operating range.

Unit is equipped with latest technology electronic expansion valve to achieve precise control of refrigerant mass flow. As today's system requires improved energy efficiency, tighter temperature control and wide operating range, the application of electronic expansion valve is the recommended solution. Electronic expansion valve provides unique features such as short opening and closing times, high resolution, positive shut-off function eliminating the need for additional solenoid valve, continuous modulation of mass flow with reduced stress in the refrigerant circuit.

Refrigerant Circuit. Each unit has one refrigerant circuits and each of them includes:

- Daikin centrifugal compressor
- Refrigerant charge
- Evaporator
- Water cooled condenser
- Electronic expansion valve
- Liquid line shut off valve
- Sight glass with moisture indicator
- High pressure transducer
- Low pressure transducer

- Oil pressure transducer
- Suction temperature sensor

Electrical Panel.

Daikin DWSC C unit has incorporated the latest microprocessor technology into the MicroTech 4 control system to give you the ultimate in chiller control. The control includes many energy-saving features to keep your chiller running efficiently . . . day in, day out, for years to come.

DWSC C units can be supplied with Daikin VFD Unit Mounted, VFD with low harmonic filter, Soft Starter or without starter (By Others – Free Standing installation).

Daikin VFD is available as Unit Mounted. Power and control sections are located into the main electrical panel IP54 designed. The main panel doors are interlocked to the main switch (standard) in order guarantee safe operation when doors are opened. The power section includes compressor protection devices and compressor starters (inverter type).

When starter is not required to be supplied with the unit, the Electrical Panel Unit mounted includes unit controller, operator interface touch screen mounted on door panel, compressor controller and 115-volt control power transformer for auxiliary circuits of the unit. See chapter Physical Data and Weights for dimensions.

MicroTech 4 Controller. The new MicroTech 4 controller is installed as standard.

MicroTech 4 built-in terminal has the following features:

- Liquid crystal display with white back lighting, supports Unicode fonts for multi-lingual;
- Key-pad consisting of 3 keys;
- Push'n'roll control for an increased usability;
- Flash memory to protect the data;
- Password access to modify the setting;
- Application security to prevent application tampering or hardware usability with third party applications;
- Alarm history memory to allow an easy fault analysis.

The controller gives the possibility to check the most relevant control parameters and to modify unit set points. A built-in display shows unit operating status. Additionally, temperatures and pressures of water, refrigerant, programmable values, set points can be accessed based on a preset list of user profiles.

A sophisticated software with adaptive logic, selects the most energy efficient combination of compressors and electronic expansion valve position to keep stable operating conditions to maximize unit energy efficiency and reliability. MicroTech 4 protects critical components based on external signals from onboard sub system (such as motor temperatures, refrigerant and oil pressures and temperatures, correctness of phase sequence, pressure switches and freezing of heat exchanger).

The input coming from high-pressure switches cuts all digital output from the controller in less than 50ms, as an additional security for the equipment. Fast program cycle (less than 200ms) for a precise monitoring of the system and sub systems. Floating point calculations supported for increased accuracy in Pressure / Temperature conversions.

Main control features are (for more information refer to Unit Control Manual):

- Management of the compressor stepless capacity;
- Control of cooling or heating leaving water temperatures;
- Optimized management of compressor load;
- Soft Load (optimized management of the compressor load during the start-up);
- Start at high heat exchanger water temperature;
- Re-start in case of power failure (automatic/manual);
- Visualization of:
 - cooling and heating entering/leaving water temperature of heat exchangers;
 - outdoor ambient temperature;
 - condensing-evaporating temperature and pressure, suction and discharge superheat for each circuit;
 - hours and starts counter for compressors and pumps;
 - status safety devices;
- Return Reset (Set Point Reset based on return water temperature);
- Set point Reset (optional);
- Unit enabled to work in partial failure condition;
- Managed operations during critical conditions:
 - High ambient temperature;
 - High thermal load;
 - Startup with high and low differential operating conditions;
 - Startup with high entering water temperature in cooling mode;
 - Startup with low entering water temperature in heating mode.

Control additional features

- Application and system upgrade with commercial SD cards;
- Save/Restore of configuration parameters with a commercial SD card;
- Ethernet port for remote or local servicing using standard web browsers;
- Two different sets of default parameters could be stored for easy restore;
- Daikin on Site connectivity for cloud-based services.

Safety device / logic (for more information refer to Unit Control Manual):

- High pressure (switch);
- High pressure (transducer);
- Low pressure (transducer);
- High discharge temperature;

- High motor winding temperature;
- Low pressure ratio;
- High oil pressure differential;
- Low oil pressure;
- No pressure changes at start.

System security:

- Phase monitor;
- Freeze protection.

Regulation type: Proportional-Integral-Derivative (PID) type based on the evaporator leaving water temperature set point (cooling mode) or based on the condenser leaving water temperature set point (heating mode).

Supervising systems (on request) MicroTech 4 remote communication: MicroTech 4 controlled is capable to communicate with BMS systems based on the most common protocols such as: Modbus, Lon Works, BACnet IP and MS/TP (class 4), Ethernet TCP/IP. Communication cards (optional) are to be selected according to the required communication protocol.

Touch Screen panel (standard) The chiller is provided with a touch screen panel. The panel is fitted inside the unit control panel for easy access. It is provided together with the App already installed allowing a ready connection to the unit controller.

NOMENCLATURE

To provide a wide range of components to match job requirements of capacity, efficiency and competitive initial cost, Daikin DWSC Centrifugal chillers are selected by Centrifugal Chiller Selection Software (CSS WEB) and identified by their components. The variations of compressor, impeller, gear ratio, evaporator and condenser tube surface and configuration provide over 1,000,000 combinations of standard components within the range of 1050 to 4500 kW. It is impractical to catalog all of these combinations. Therefore, computer selection for specific application conditions is required. The complete unit model code is then established as follows:

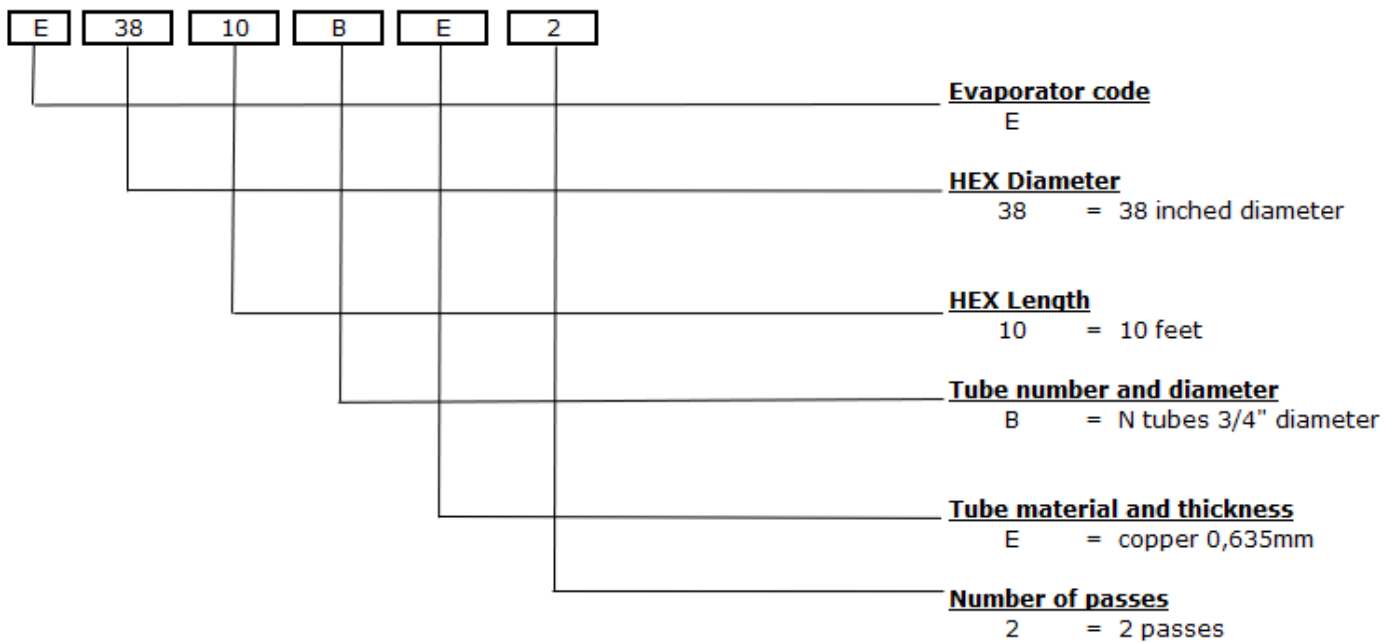
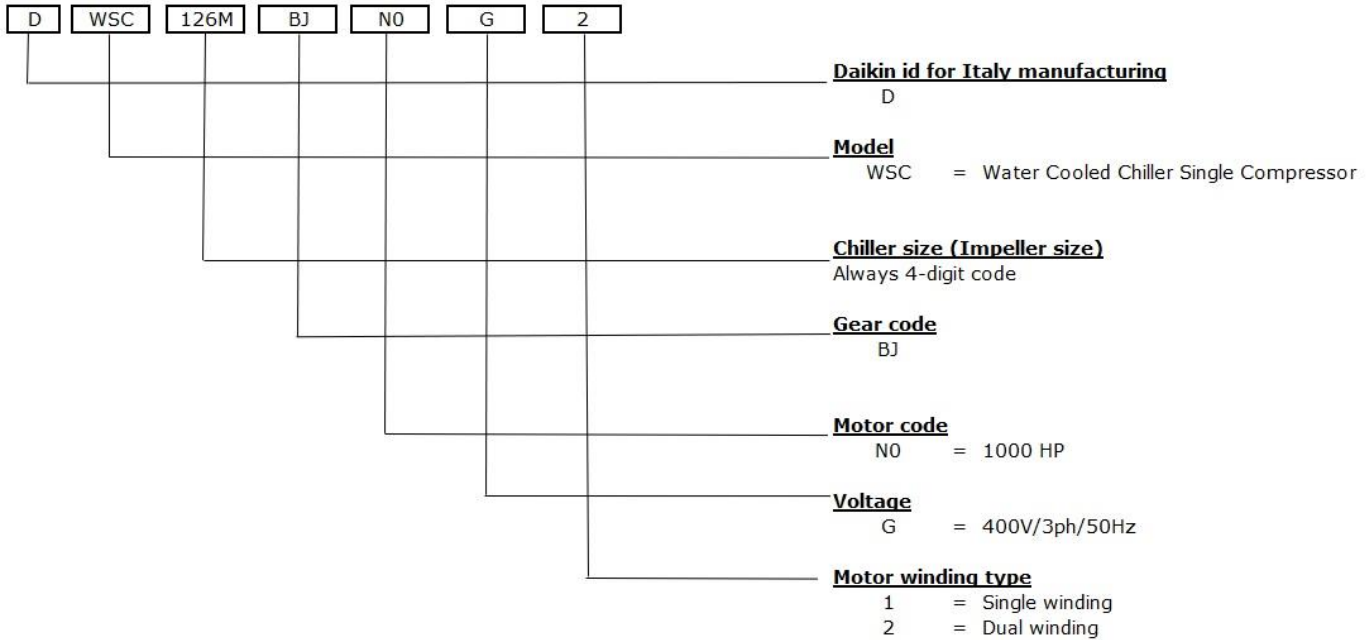

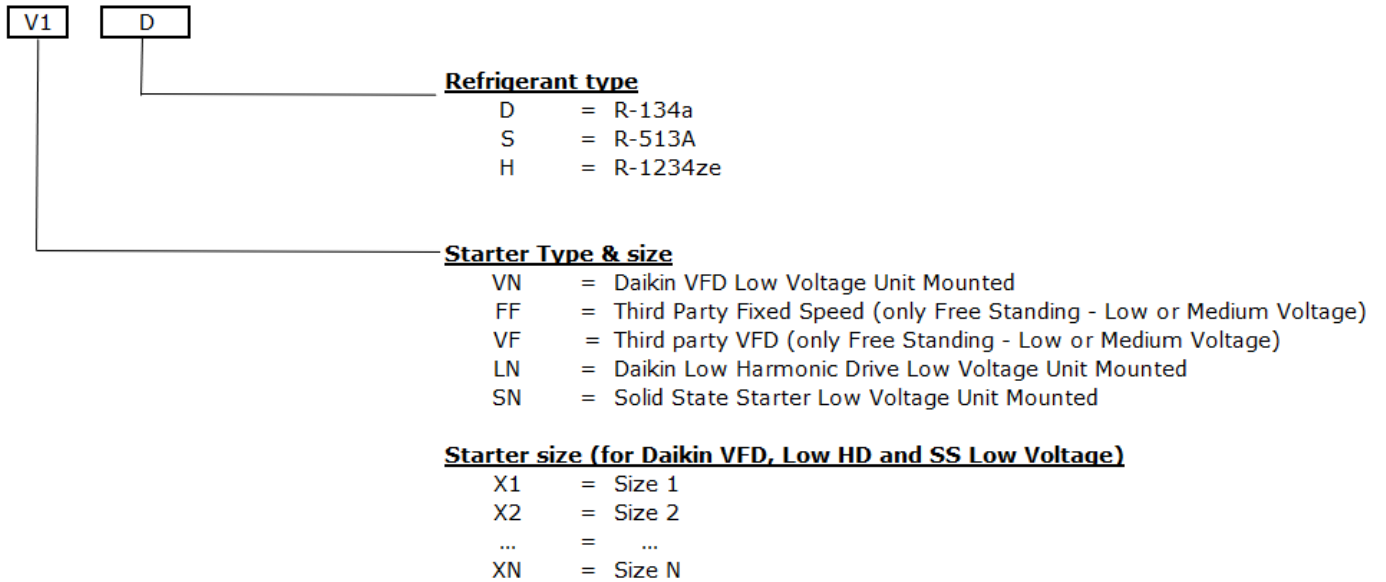
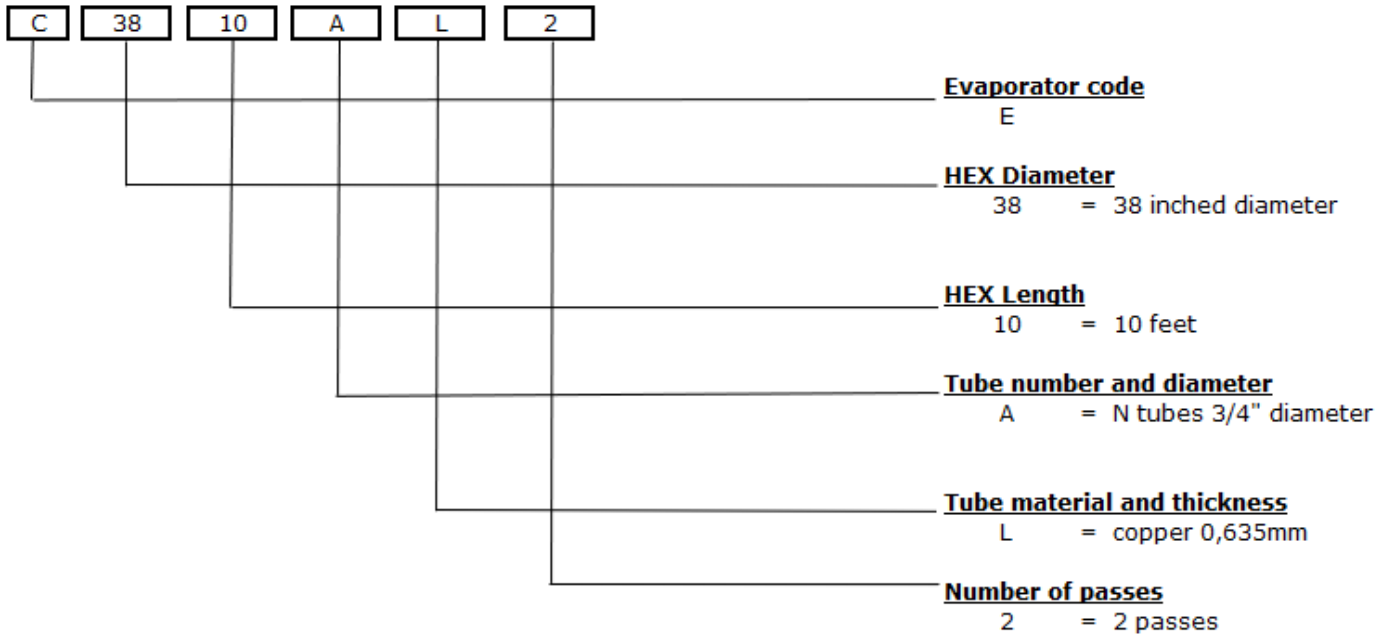

OPTIONS AND ACCESSORIES

Mechanical

167 Marine Version. Please contact factory to analyze project specifications.

07a Heat Pump (including Pursuit mode). The Heat Pump Version includes Pursuit Mode and allows reversibility on the water side. Cooling or heating mode operation can be selected by means of a dedicated switch installed on the unit electrical panel. If communication card is selected, cooling or heating mode operation can be managed by BMS. It always includes HGBP (option 175) and an additional insulation of 20 mm on the condenser. (option 33)

175 Hot Gas By Pass. Reduces compressor cycling and its attendant chilled water temperature swings at very low loads. Included in option **07a Heat Pump**.

121 Refrigerant leak detection. Electronic device for automatic detection of refrigerant leak. The leak detection device is supplied by factory and installed mounted on the unit (bottom side of the frame). When leak above a pre-set concentration of refrigerant is detected, signal is sent to unit controller (a specific alarm is visualized on the unit microprocessor's display). The Factory supply interconnecting cables between leak detection device and unit controller.

61 Discharge Line Shut-off Valve.

62 Suction Line Shut-off Valve.

76-b Low noise (Discharge Line only). Incompatibility with **76-d Low noise (Condenser & Discharge Line)**. Optional discharge line sound package is offered. An additional 1.5 dB(A) reduction normally occurs.

76-d Low noise (Condenser & Discharge Line). Incompatibility with **76-b Low noise (Discharge only)**. For extremely sensitive projects, an optional unit mounted sound package is offered consisting of sound insulation installed on the unit's discharge line and condenser. An additional 10dB(A) reduction normally occurs.

63 High Pressure side manometer.

64 Low Pressure side manometer.

194 ASME certification for evaporator and condenser. PED Certification is standard. This option has impact on unit lead time.

Heat Exchangers

201 Evaporator Inlet Right. Inlet Left is standard, having Electrical panel to Front View.

202 Condenser Inlet Right. Inlet Left is standard, having Electrical panel to Front View.

104 Evaporator Flanges. Flanged connections on water side heat exchanger. Victaulic kit is included as standard.

196 Evaporator Counter-flanges including counter-flanges, gaskets and bolts.

26 Condenser Flanges. Flanged connections on water side heat exchanger. Victaulic kit is included as standard.

197 Condenser Counter-flanges including counter-flanges, gaskets and bolts.

198 40mm Evaporator insulation. Double insulation on evaporator, suction piping, and motor barrel; For high humidity locations and ice making applications. Standard is 20mm evaporator insulation on evaporator, suction piping, and motor barrel; for normal machine room applications.

33 20 mm Condenser insulation. Included in option **07a Heat Pump**.

27 Evaporator Water Side design pressure 16bar. Standard is 10bar. For high-pressure water systems, typically high-rise building construction. This option has impact on unit lead time.

47 Condenser Water Side design pressure 16bar. Standard is 10bar. For high-pressure water systems, typically high-rise building construction. This option has impact on unit lead time.

22 EVAPORATOR MARINE WATERBOX (2 PASSES). Provides tube access for inspection, cleaning, and removal without dismantling water piping. Victaulic kit is included in the option.

22a Evaporator MWB 1 pass (on both ends). Victaulic kit is included in the option.

23 Evaporator MWB 3 passes (on both ends). Victaulic kit is included in the option.

38 CONDENSER MARINE WATERBOX (2 PASSES). Victaulic kit is included in the option.

38a Cond MWB 1 pass (on both ends). Victaulic kit is included in the option.

39 Cond MWB 3 passes (on both ends). Victaulic kit is included in the option.

209 EVAPORATOR HINGES ON BOTH ENDS.

210 CONDENSER HINGES ON BOTH ENDS.

211 EVAPORATOR SACRIFICIAL ANODES.

212 CONDENSER SACRIFICIAL ANODES.

213 EVAPORATOR CERAMIC COATING (WATER SIDE).

214 CONDENSER CERAMIC COATING (WATER SIDE).

215 EVAPORATOR EPOXY COATING (WATER SIDE).

216 CONDENSER EPOXY COATING (WATER SIDE).

Electrical

110 Rapid restart. Ideal solution for those critical applications that cannot afford the loss of cooling. In case of power failure unit will re-start as fast as 26 seconds from power restoration. Unit will reach full load within 280 seconds and 360 seconds respectively for single compressor and dual compressors unit models. Refer to unit control manual for more information about this option.

58 Evaporator Flow Switch. This option provides evaporator water thermal dispersion flow sensors as a factory mounted and wired option. A proof-of-flow device is mandatory in both the chilled water and condenser water systems.

59 Condenser Flow Switch.

56 Evaporator Water differential pressure switches.

55 Condenser Water differential pressure switches.

Software

155 DAIKIN ON SITE MODEM (WITH ANTENNA). With Daikin On Site it is possible to have complete access to the unit controller through the cloud. The unit is equipped with a modem and a GSM card providing autonomous internet connection. As alternative, a LAN connection can be used if available.

The main functionalities of DoS are:

- predefined set of data points (~300 to >500 per controller/plant);
- predefined Read/Write access to data points;
- predefined set of dashboards;
- functionality for users to create their own dashboards;
- alarm application and alarm history;
- alarm notification via email;
- scheduling of alarm notification;
- WEB-Access to local HMI;
- Dynamic WEB-Graphic;
- possibility to upgrade firmware and software from remote (for some user roles);
- history log for cloud-based user interactions (e.g. change of a set point);
- scheduler application;
- documentation folder (E.g. release notes).

Option incompatibility: 182

184 iCM Standard. By selecting this option is possible to achieve the control of the primary loop without need of additional control panel. The option adds much more functionalities than those provided by standard Master/Slave. Contact the factory for more detailed information.

180 Modbus RTU MSTP. Option incompatibility: 181-182

181 BACNet MSTP. Option incompatibility: 180-182

182 BACNet IP. Option incompatibility: 155-180-181

Other

195 Knockdown (On-site disassembly). Disassemble the unit on site. The units are shipped fully assembled, factory charged, run- tested, insulated and painted. Included are the vessel bolt-on connection brackets, discharge line bolt-on flanges

at the condenser and bolt-on oil pump assembly. Site disassembly and reassembly must be supervised by Daikin startup personnel. Contact local Daikin Factory Service for price quotation and scheduling. This option has impact on unit lead time.

147 Knockdown Electrical Panel. Disassemble the Electrical panel before unit shipment. This option has impact on unit lead time.

Starter Options (Available when starter is Unit Mounted only)

16 Energy Meter.

102 Ground Fault Protection.

207 REVERSED LINE CABLE ENTRY (FROM THE TOP). Standard is from Bottom. Additional width of the panel: +300mm. No impact on overall chiller width.

208 IT-NET CONFIGURATION. This option has impact on unit lead time

Special Order Options

The following special order options are available; requiring factory pricing, additional engineering and possible dimension changes or extended delivery: Consult the Daikin sales office for other possible specials.

- Non-standard location of nozzle connections on heads (compact water boxes) or marine water boxes
- Special corrosion inhibiting coatings on any "wetted surface" including tubesheets, heads (compact water boxes), marine water boxes, or nozzles
- Clad tube sheets
- Sacrificial anodes in heads (compact water boxes) or marine water boxes
- Special IP/ NEMA enclosures
- Hinges for marine water box covers or heads (compact water boxes)
- Accelerometer and vibration monitoring pickup mounting (DWSC/DWDC)
- Rubber or Spring AVMS
- Spacer rings on heads to accommodate automatic tube brush cleaning systems (installed by others)

English or Metric Display (SI or IP)

Either English or metric units for operator ease of use.

Extended warranties

Extended 1, 2, 3, or 4-year warranties for parts only or for parts and labor are available for the entire unit, refrigerant or compressor/motor only.

Optional Witness Test

A Daikin engineer oversees the testing in the presence of the customer or their designate and translates the test data onto an easy-to-read spreadsheet. The tests can be run at AHRI load points and are run to AHRI tolerance of capacity and power. Allow two to three hours of test time per load point specified. Units built for 50 Hz power can be run-tested using an onsite 50 Hz generator. A test result booklet will be provided.

Physical Data and Weights

Evaporator

Refrigerant side design pressure is 13,7bar on DWSC units.

DWSC evaporators are 13,7bar.

Standard water-side design pressure is 10bar (145psi) on DWSC. 16 bar (232psi) is available as option.

Evaporator Physical Data

code	Water Volume (L)	Insulation Area (m ²)	Vessel Dry Weight (kg)	Add for MWB (kg)	MWB Cover only, Weight (kg)
E2410	248	9	1530	233	106
E2610	318	10	1924	247	125
E3210	579	12,0	2122	354	202
E3810	888	14,5	3100	572	344
E4410	1275	17,0	3849	771	498

Notes:

1. Water capacity is based on standard tube configuration and standard heads.
2. Vessel weight includes the shell, maximum tubes, and standard heads, no refrigerant.
3. MWB, marine water box, weight add is the water box weight minus a standard dished head weight.

Condenser

Refrigerant side design pressure is 13,7bar on DWSC units.

DWSC condensers are 13,7bar.

Standard water-side design pressure is 10bar (145psi) on DWSC. 16 bar (232psi) is available as option.

Pumpdown

To facilitate compressor service, all DWSC centrifugal chillers are designed to permit pumpdown and isolation of the entire refrigerant charge in the unit's condenser. DWSC single compressor units equipped with the optional suction shutoff valve, can also be pumped down into the evaporator.

Condenser Physical Data

code	Water Volume (L)	Insulation Area (m ²)	Vessel Dry Weight (kg)	Add for MWB (kg)	MWB Cover only, Weight (kg)
C2210	346	8,2	1770	206	94
C2410	438	8,9	2193	233	106
C2810	616	10,4	2314	270	143
C3010	717	11,0	2499	329	191
C3210	852	11,8	2706	354	202
C3810	1257	14,2	3952	571	344
C4010	1418	14,8	4224	592	377

Notes:

1. Water capacity is based on standard tube configuration and standard heads.
2. Vessel weight includes the shell, maximum tubes, and standard heads, no refrigerant.
3. MWB, marine water box, weight add is the water box weight minus a standard dished head weight

Compressor Weight

Code	Weight (kg)
079L	1440
087M	1440
100M	2700
113M	2700
126M	2700

**Complete Unit
Unit Weights, Single Compressor, DWSC**

Unit	Evaporator/Co ndenser Size	Unit Refrig. Charge (1) (kg)	Max. Unit Weight w/o Starter		Max. Unit Weight with Control Box	
			Shipping (kg)	Operating (kg)	Shipping (kg)	Operating (kg)
DWSC079L	E2410-C2210	292,3	5582	6193	5798	6409
	E2410-C2410	305,2	6002	6707	6218	6923
	E2610-C2410	345,2	6387	7164	6604	7380
	E2610-C2810	381,6	6751	7712	6968	7928
	E3210-C2810	519,6	7535	8756	7752	8972
DWSC087M	E2410-C2210	292,3	5582	6193	5798	6409
	E2410-C2410	305,2	6002	6707	6218	6923
	E2610-C2410	345,2	6387	7164	6604	7380
	E2610-C2810	381,6	6751	7712	6968	7928
	E3210-C2810	519,6	7535	8756	7752	8972
	E3210-C3010	531,5	7700	9025	7916	9241
	E3210-C3210	560,6	7927	9358	8143	9575
	E3810-C3010	699,6	8957	10628	9174	10844
DWSC100M DWSC113M	E3810-C3210	728,6	9185	10961	9401	11177
	E3210-C2810	519,6	9240	10434	9374	10568
	E3210-C3010	531,5	9425	10721	9559	10854
	E3210-C3210	560,6	9650	11081	9784	11215
	E3810-C3010	699,6	10718	12323	10852	12457
	E3810-C3210	728,6	10997	12737	11131	12871
	E3810-C3810	770,1	12193	14339	12327	14473
	E3810-C4010	804,3	12537	14843	12671	14977
	E4410-C3810	967,2	13215	15747	13349	15882
	E4410-C4010	1001,5	13461	16153	13595	16287
DWSC126M	E3210-C3010	531,5	9425	10721	9559	10854
	E3210-C3210	560,6	9650	11081	9784	11215
	E3810-C3010	699,6	10718	12323	10852	12457
	E3810-C3210	728,6	10997	12737	11131	12871
	E3810-C3810	770,1	12193	14339	12327	14473
	E3810-C4010	804,3	12537	14843	12671	14977
	E4410-C3810	967,2	13215	15747	13349	15882
	E4410-C4010	1001,5	13461	16153	13595	16287

Notes:

1. Weight of the Electrical box see VFD data.

1. Physical Data and Weights for component and unit included in this section are for rough layout purposes only. Detailed certified drawings, as pdf hard copies or CAD files, are available from the local sales office. Do not use catalog drawings for final construction.

2. Obtain specific unit certified drawings for detailed dimensions of water, oil cooler, and relief valve connections.

ELECTRICAL DATA

Wiring and Conduit

Wire sizes must comply with local and state electrical codes. Where total amperes require larger conductors than a single conduit would permit, limited by dimensions of motor terminal box, two or more conduits can be used. Where multiple conduits are used, all three phases must be balanced in each conduit. Failure to balance each conduit will result in excessive heating of the conductors and unbalanced voltage.

An interposing relay can be required on remote mounted starter applications when the length of the conductors run between the chiller and starter is excessive.

Use only copper supply wires with ampacity based on 75°C conductor rating. (Exception: for equipment rated over 2000 volts, 90°C or 105°C rated conductors shall be used).

Motor Starters

Daikin has a wide variety of starter types and options to fit virtually all applications. Contact the factory for details. This section contains a general overview only. See IOM manual of for more details on technical information.

Daikin VFD, Low Voltage Unit Mounted - Starter Type: VN

DWSC C units can be supplied with Daikin VFD Unit Mounted.

Daikin VFDs are furnished, mounted and wired in the factory. Due to shipping width limitations, the starters for DWSC100 through 126 may be shipped loose with cable kits and mounting brackets for field installation on the unit by others. Please contact the logistic department for certified drawing.

Size	V1	V2	V3	V4	V5	V6	V7	V8	V9	VA	VB
Frame	200.1	250.1	330.1	350.1	400.1	450.2	500.2	540.2	660.2	680.2	800.2
Output Amps [A]	400	440	545	600	700	730	800	900	1090	1200	1400
Width [mm]	1500						2000				
Depth [mm]	500						500				
Height [mm]	1800						1800				
Weight [kg]	600						900				
Colour	Ivory White (Munsell code 5Y7.5/1 ± RAL7044)										
Material	Galvanized and painted steel sheet										
Degree of protection	IP54 (enclosure) - IPXXB (inside panel)										
Operating Temperature [°C]	0°C...+45°C										
Voltage [V]	380-415V +/-10%										
Frequency [Hz]	50/60 +/-5%										
Line cable entry	TOP (op BOTTOM)						BOTTOM (op TOP dimensions change)				

Daikin Low Harmonic VFD, Low Voltage Unit Mounted - Starter Type: LN

Size	L6	L7	L8	L9	LA	LB
Frame	450.2	500.2	540.2	660.2	680.2	800.2
Output Amps [A]	730	800	900	1090	1200	1400
Width [mm]	3000					
Depth [mm]	600					
Height [mm]	1800					
Weight [kg]	1400	1520		1600		
Colour	Ivory White (Munsell code 5Y7.5/1 ± RAL7044)					
Material	Galvanized and painted steel sheet					
Degree of protection	IP54 (enclosure) - IPXXB (inside panel)					
Operating Temperature [°C]	0°C...+45°C					
Voltage [V]	380-415V +/-10%					
Frequency [Hz]	50/60 +/-5%					
Line cable entry	BOTTOM					

Daikin Soft Starter, Low Voltage Unit Mounted - Starter Type: SN

Size	S1	S2	S3	S4	S5	S6	S7	S8	S9	SA	SB	SC
Frame	124	170	210	250	300	370	470	570	720	840	1050	1250
Max RLA [A]	186	242	275	355	433	518	687	845	1027	1201	1515	1788
Width [mm]	1500				2000							
Depth [mm]	510				510							
Height [mm]	1500				1800							
Weight [kg]	150				220							
Colour	Ivory White (Munsell code 5Y7.5/1, ± RAL7044)											
Material	Galvanized and painted steel sheet											
Degree of protection	IP54 (enclosure) - IPXXB (inside panel)											
Operating Temperature [°C]	0°C...+45°C											
Voltage [V]	380-415V +/-10%											
Frequency [Hz]	50/60 +/-5%											
Line cable entry	BOTTOM (op TOP dimensions change)											

Daikin electrical Panel - Only Control, Low Voltage Unit Mounted, available for Third Party Starter below listed:

FF = Fixed Speed (only Free Standing - Low or Medium Voltage)

VF = VFD (only Free Standing - Low or Medium Voltage)

Width [mm]	650
Depth [mm]	431
Height [mm]	1575
Weight [kg]	210
Colour	Ivory White (Munsell code 5Y7.5/1 ± RAL7044)
Material	Galvanized and painted steel sheet
Degree of protection	IP54 (enclosure) - IPXXB (inside panel)
Operating Temperature [°C]	0°C...+45°C
Voltage [V]	380-415V +/-10%
Frequency [Hz]	50/60 +/-5%

Freestanding

Furnished by Daikin and shipped to the job site for setting and wiring by others.

Starters by others

Starters furnished by others must meet Daikin Specification. For additional information please contact the factory. The starters are furnished and installed by others.

Mounting Options, Medium Voltage

All starter types in these voltages are for field setting and wiring only.

APPLICATION CONSIDERATIONS

Location

These chillers are intended only for installation in an indoor or weather protected area consistent with the IP54 (equivalent to NEMA 12 Indoor) rating on the chiller, controls, and electrical panels. If indoor sub-freezing temperatures are possible, special precautions must be taken to avoid equipment damage.

CAUTION

Daikin Centrifugal Chillers are intended only for installation in indoor areas protected from temperature extremes. Failure to comply may result in equipment damage and may void the manufacturer warranty.

Operating/Standby Limits

Table 5: Operating/Standby Limits

Equipment room operating temperature:	40°-104°F (4.4°-40°C)
Equipment room temperature, standby, with water in vessels and oil cooler:	40°-104°F (4.4°-40°C)
Equipment room temperature, standby, without water in vessels and oil cooler:	0°F-122F (-18°C-50°C)
Maximum entering condenser water temperature, startup:	design + 5°F (2.7°C)
Maximum entering condenser water temperature, operating:	job-specific design temperature
Minimum entering condenser water temperature, operating:	see this page for more detail
Minimum leaving chilled water temperature:	38°F (3.3°C)
Minimum leaving chilled fluid temperature with correct anti-freeze fluid:	15°F (-9.4°C)
Maximum entering chilled water temperature, operating:	90°F (32.2°C)
Maximum oil cooler or VFD entering temperature:	80°F (26.7°C)
Minimum oil cooler/VFD entering temperature:	42°F (5.6°C)

Water Piping

All evaporators and condensers have OGS-type grooved water connections (adhering to Standard AWWA C606) or optional flange connections. The installing contractor must provide matching mechanical connections. PVC piping should not be used. Be sure that water inlet and outlet connections match certified drawings and nozzle markings.

CAUTION

If welding is to be performed on the mechanical or flange connections:

1. Remove the solid-state temperature sensor, thermostat bulbs, and nozzle mounted flow switches from the wells to prevent damage to those components.
2. Properly ground the unit or severe damage to the MicroTech® unit controller can occur.

NOTE: PED/ASME certification will be revoked if welding is performed on a vessel shell or tube sheet.

The water heads can be interchanged (end for end) so that the water connections can be made at either end of the unit. If this is done, use new head gaskets and relocate the control sensors.

Field installed water piping to the chiller must include:

- air vents at the high points.
- a cleanable water strainer upstream of the evaporator and condenser inlet connections.
- a flow proving device for both the evaporator and condenser to prevent freeze up. Flow switches, thermal dispersion switches, or Delta-P switches can be used.

Note that flow switches are factory installed. Additional flow switches can be used only if they are connected in series with the ones already provided. Connect additional flow switches in series between original flow switch inputs.

- sufficient shutoff valves to allow vessel isolation. The chiller must be capable of draining the water from the evaporator or condenser without draining the complete system.

It is recommended that field installed water piping to the chiller include:

- thermometers at the inlet and outlet connections of both vessels.
- water pressure gauge connection taps and gauges at the inlet and outlet connections of both vessels for measuring water pressure drop.

The piping must be supported to eliminate weight and strain on the fittings and connections. Piping must also be adequately insulated. Sufficient shutoff valves must be installed to permit draining the water from the evaporator or condenser without draining the complete system.

Optimum Water Temperatures and Flow Rates

A key to improving energy efficiency for any chiller is minimizing the compressor pressure lift. Reducing the lift reduces the compressor work and its energy consumption per unit of output.

The optimum plant design must take into account all of the interactions between chiller, pumps, and tower.

Contact the factory for assistance on your particular application.

Evaporator

Evaporator temperature drop

The industry standard has been a ten-degree temperature drop in the evaporator. Increasing the drop to 12 or 14 degrees will improve the evaporator heat transfer, raise the suction pressure, and improve chiller efficiency. Chilled water pump energy will also be reduced.

Higher leaving chilled water temperatures

Warmer leaving chilled water temperatures will raise the compressor's suction pressure and decrease the lift, improving efficiency. Using 45° F (7.0° C) leaving water instead of 42° F (5.5° C) will make a significant improvement.

Condenser

Condenser entering water temperature

As a general rule, a one-degree drop in condenser entering water temperature will reduce chiller energy consumption by two percent. Cooler water lowers the condensing pressure and reduces compressor work. One or two degrees can make a noticeable difference. The incremental cost of a larger tower can be small and provide a good return on investment.

Minimum Condenser Water Temperature Operation

When ambient wet bulb temperatures are lower than design, the condenser water temperature can be allowed to fall. Lower temperatures will improve chiller performance.

Depending on local climatic conditions, using the lowest possible entering condenser water temperature may be more costly in total system power consumed than the expected savings in chiller power would suggest, due to the excessive fan power required. Cooling tower fans must continue to operate at 100% capacity at low wet bulb temperatures. As chillers are selected for lower kW per ton, the cooling tower fan motor power becomes a higher percentage of the total peak load chiller power.

Even with tower fan control, some form of water flow control, such as tower bypass, is recommended.

Condenser water temperature rise

The industry standard of 3 gpm/ton or about a 9.5-degree delta-T works well for most applications. Reducing condenser water flow to lower pumping energy will increase the water temperature rise, resulting in an increase in the compressor's condensing pressure and energy consumption. This is usually not a productive strategy.

System analysis

Although Daikin is a proponent of analyzing the entire system, it is generally effective to place the chiller in the most efficient mode because it is, by far, a larger energy consumer than pumps. It is especially good at comparing different system types and operating parameters. Utility costs, load factors, maintenance costs, cost of capital, tax bracket; essentially all factors affecting owning cost, must be considered as well.

Generally, the attempts to save the last few full load kW are very costly. For example, the cost to go from 0.58 to 0.57 kW/ton could be very costly because of the large number of copper tubes that would have to be added to the heat exchangers. Contact factory for assistance on your particular application.

Mixing Single and Dual Compressor Chillers

DWDC dual compressor chillers excel at part load operation, while single compressor chillers usually have better full load efficiency. A good chiller plant strategy is to install one dual and one or more single compressor units. Run the dual until it is fully loaded, then switch to the single compressor unit and run it only at full load, using the dual to trim the load.

Series Counterflow and Series Parallel Chillers

The design of piping systems can greatly impact chiller performance. A popular system is to place the evaporators in series with the chilled water flowing from one evaporator to the next as shown. Two different condenser water piping arrangements can be used. Parallel flow (Figure 8) divides the total condenser flow between the two condensers. The counterflow system (Figure 9) puts all of the condenser water through the condenser of the lag chiller (chiller producing the coldest evaporator leaving water) and then through the lead chiller (chiller seeing the warmest evaporator water temperatures).

Typically, since the lead machine will see the warmest evaporator water, it will have the greater capacity and larger portion of the total system evaporator temperature drop. The lead machine has an 8.4 degree drop (56.0°F-47.6°F) and the lag machine has a 5.6 degree drop (47.6°F - 42.0°F).

Condenser water flow is important to overall system efficiency. With parallel flow, the condensers have identical flow conditions (95 to 85 degrees in this example) with the compressor lift shown. With counterflow arrangement the lift on the lead machine is significantly lower, reducing compressor work and making the overall system efficiency about 2% better.

Even though the chiller performance is different, it is good practice to use the same chiller models. Both the DWSC and DWDC chillers are suitable for series counterflow arrangement and include controls specifically designed for series chillers. For more information, please refer to Application guide AG -31-003: Chiller Plant Design.

Figure 8: Series Parallel Flow

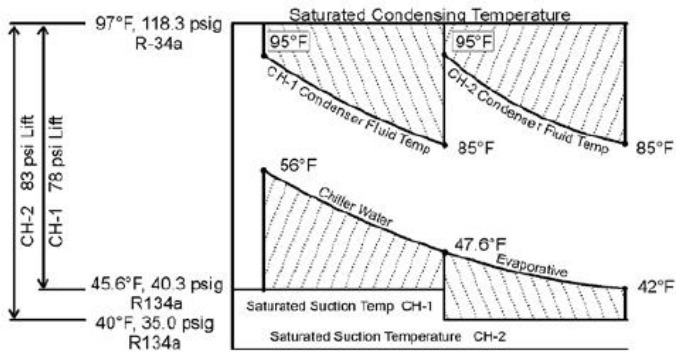
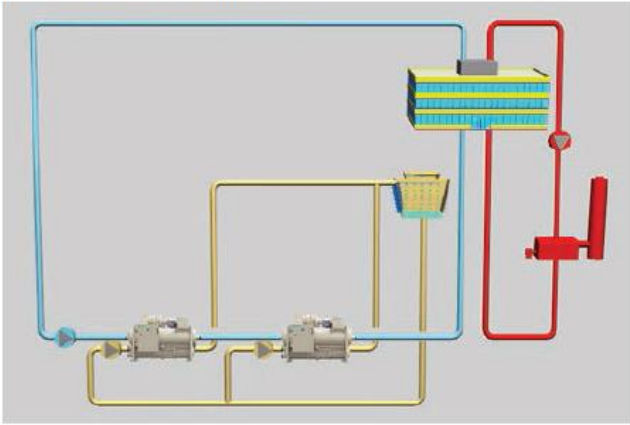
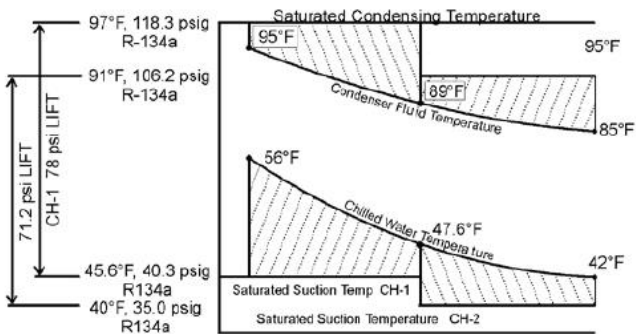
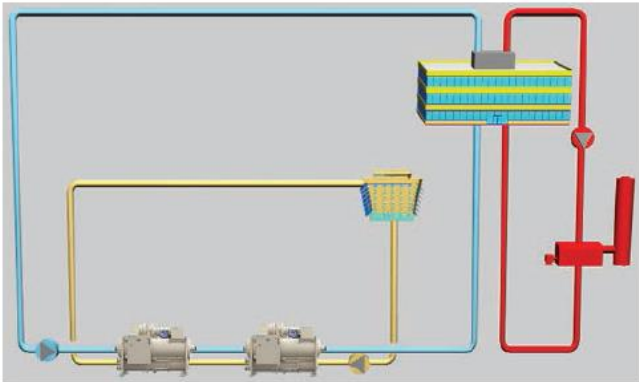

Figure 9: Series Counterflow Flow



Oil Coolers

Daikin centrifugal chillers have a factory-mounted oil cooler with a temperature controlled water regulating valve and solenoid valve for each compressor. Cooling water connections are located at the rear of the unit, near the compressor and are shown on the specific unit certified drawings. Models DWDC 079 & 087 have the cooling water connections in the lower portion of one tube

sheet.

DWDC 079, 087, 100 and 126 dual compressor chillers are equipped as above, but the water piping for the two oil coolers is factory piped to a common inlet and outlet connection.

Field water piping to the inlet and outlet connections must be installed according to good piping practices and must include stop valves to isolate the cooler for servicing. A 1" minimum cleanable filter (40 mesh maximum) and drain valve or plug must also be field installed. The water supply for the oil cooler must be from the chilled water circuit, or from an independent clean source such as city water. When using chilled water, it is important that the water pressure drop across the evaporator is greater than the pressure drop across the oil cooler or insufficient oil cooler flow will result. If the pressure drop across the evaporator is less than the oil cooler, the oil cooler must be piped across the chilled water pump, provided that its pressure drop is sufficient. The water flow through the oil cooler will be adjusted by the unit's regulating valve so that the temperature of oil supplied to the compressor bearings (leaving the oil cooler) is between 90°F and 110°F (32°C and 43°C).

NOTE: The system must be designed for the highest cooling water temperature possible, which may occur for a short time during startup.

Compressors using chilled water for oil cooling will often start with warm "chilled water" in the system until the chilled water loop temperature is pulled down. With cooling water in the 40°F to 55°F (4°C to 13°C) range, considerably less water will be used and the pressure drop will be greatly reduced. The following table contains oil cooler data at various inlet water temperatures.

When supplied with city water, the oil piping must discharge through a trap into an open drain to prevent draining the cooler by siphoning. The city water can also be used for cooling tower makeup by discharging it into the tower sump from a point above the highest possible water level.

Note: Particular attention must be paid to chillers with variable chilled water flow through the evaporator. The pressure drop available at low flow rates can very well be insufficient to supply the oil cooler with enough water. In this case an auxiliary booster pump can be used or city water employed.

Cooling Water Connection Sizes: DWDC 100/126 have 1-1/2 in. FPT connections, all other WDC and DWSC are 1 in. FPT

Table 6: DWSC Oil Cooler Data

	Hot Side POE Lube	Cold Side Water			
DWSC 079 - 087					
Flow, gpm	9.9	11.9	2.9	2.0	1.54
Inlet Temperature, °F	118.0	80.0	65.0	55.0	45.0
Outlet Temp., °F	100.0	87.3	94.5	98.3	101.4
Pressure Drop, psi	-	4.3	0.3	0.14	0.09
DWSC 100 - 126					
Flow, gpm	15.8	21.9	5.11	3.5	2.7
Inlet Temperature, °F	120.0	80.0	65.0	55.0	45.0
Outlet Temp., °F	100.0	87.0	95.0	99.0	102.3
Pressure Drop, psi	-	3.78	0.23	0.11	0.07

NOTE: Pressure drops include valves on the unit; DWDC units have twice the cooling water flow rate of the comparable DWSC chiller.

Figure 18: DWSC/DWDC Oil Cooler Piping Across Chilled Water Pump

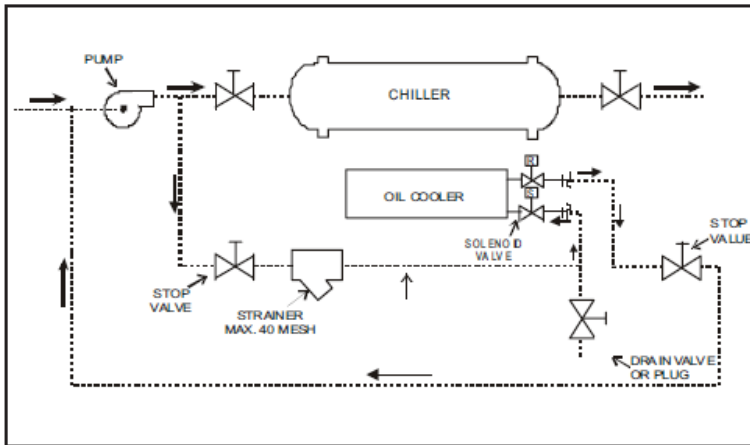
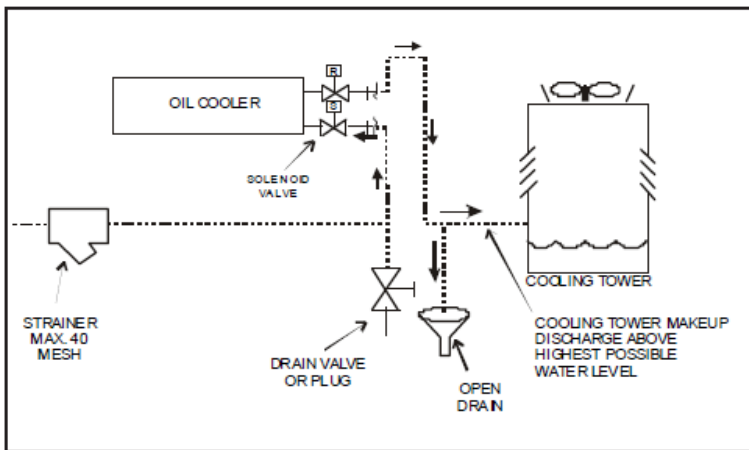

Figure 19: DWSC/DWDC Oil Cooler Piping With City Water



Pumps

DWSC, DWDC chiller compressor motors operate at 3600 rpm on 60 Hz power (3000 rpm on 50 Hz). When VFDs are employed, the hertz/speed can be reduced by 70%. To avoid the possibility of objectionable harmonics in the system piping, 4-pole, 1800/1500 rpm system pumps should be used. The condenser water pump(s) must be cycled off when the last chiller of the system cycles off. This will keep cold condenser water from migrating refrigerant to the condenser. Cold liquid refrigerant in the condenser can make start-up difficult. In addition, turning off the condenser water pump(s) when the chillers are not operating will conserve energy.

Include thermometers and pressure gauges at the chiller inlet and outlet connections and air vents at the high points of piping. The water heads can be interchanged (end for end), allowing water connections to be made at either end of the unit. Use new head gaskets when interchanging water heads.

When water pump noise is objectionable, use rubber isolation sections at both the inlet and outlet of the pump. Vibration eliminator sections in the condenser inlet and outlet water lines are not normally required. Where noise and vibration are critical and the unit is mounted on spring isolators, flexible piping and conduit connections are necessary. If not factory installed, a flow switch or pressure differential switch must be installed in the leaving chilled water line in accordance with the flow switch manufacturer's instructions.

Victaulic connections are AWWA C-606 on 14-inch and larger sizes. Field supply transitions if Victaulic brand AGS® (Advanced Groove System) type grooves are used on the field piping.

Filtering and Treatment

Owners and operators must be aware that if the unit is operating with a cooling tower, cleaning and flushing the cooling tower is required. Ensure tower blow-down or bleedoff is operating. Atmospheric air contains many contaminants, which increases the need for water treatment. The use of untreated water will result in corrosion, erosion, slime buildup, scaling, or algae formation. A water treatment service should be used. Daikin is not responsible for damage or faulty operation from untreated or improperly treated water.

Machine Room Ventilation

In the market today, centrifugal chillers are available with either hermetic or open type motors. Hermetic motors are cooled with refrigerant and dissipate their heat through the cooling tower. On the other hand, open motors circulate equipment room air across themselves for cooling and reject the heat to the equipment room. Daikin chillers have hermetic motors and DO NOT require additional ventilation.

For chillers with open-drive type, air-cooled motors, good engineering practice dictates that the motor heat be removed to prevent high equipment room temperatures. In many applications this requires a large volume of ventilation air, or mechanical cooling to properly remove this motor heat.

EXAMPLE: 1000 tons x 0.6 kW/Ton x 0.04 motor heat loss x 0.284 Tons/kW = 7 tons (24 kW) cooling

The energy and installation costs of ventilation or mechanical cooling equipment must be considered when evaluating various chillers. For a fair comparison, the kW used for the ventilation fans, or if mechanical cooling is required, the additional cooling and fan energy must be added to the open motor compressor energy when comparing hermetic drives. Additionally, significant costs occur for the purchase, installation, and maintenance of the ventilation or air handling units.

Equipment room ventilation and safety requirements for various refrigerants is a complex subject and is updated from time to time. The latest edition of EN378 Safety Classification or ASHRAE 15 should be consulted.

Thermal Storage

Daikin chillers are designed for use in thermal storage systems. The chillers have two operating conditions that must be considered. The first is normal air-conditioning duty where leaving evaporator fluid temperatures range from 40°F to 45°F (4.4°C to 7.2°C). The second condition occurs during the ice making process when leaving fluid temperatures are in the 22°F to 26°F (-5.6°C to -3.3°C) range.

The control system will accommodate both operating points. The ice mode can be started or stopped by an input signal to the microprocessor from a BAS or through a chilled water reset signal. When a signal is received to change from the ice mode to the normal operating mode, the chiller will shut down until the system fluid temperature rises to the higher setpoint. The chiller will then restart and continue operation at the higher leaving fluid temperature. When changing from normal cooling to the ice mode, the chiller will load to maximum capacity until the lower setpoint is reached.

Computer selections must be made to check that the chiller will operate at both conditions. If the "ice mode" is at night, the pressure differentials between the evaporator and condenser are usually similar to normal cooling applications. The leaving fluid temperature is lower, but the condensing temperature is also lower because the cooling tower water is colder. If the ice mode can also operate during the day, when cooling tower water temperatures are high, a proper selection becomes more difficult because the two refrigerant pressure differentials are significantly different.

A three-way condenser water control valve is always required.

Variable Speed Pumping

Variable speed pumping involves changing system water flow relative to cooling load changes. Daikin centrifugal chillers are designed for this duty with two limitations.

First, the rate of change in the water flow needs to be slow, not greater than 10% of the change per minute. The chiller needs time to sense a load change and respond.

Second, the water velocity in the vessels must be 3 to 10 fps (0.91 and 3.0 m/sec). Below 3 fps (0.91 m/sec), laminar flow occurs which reduces heat transfer. Above 10 fps (3.0 m/sec), excessively high pressure drops and tube erosion occur.

These flow limits can be determined from the Daikin selection program.

We recommend variable flow only in the evaporator because there is virtually no change in chiller efficiency compared to constant flow. In other words, there is no chiller energy penalty. Although variable speed pumping can be done in the condenser loop, it is usually unwise. The intent of variable flow is to reduce pump horsepower. However, reducing condenser water flow increases the chiller's condensing pressure, increasing the lift that the compressor must overcome which, in turn, increases the compressor's energy use. Consequently, pump energy savings can be lost because the chiller operating power is significantly increased.

Low condenser flow can cause premature tube fouling and subsequent increased compressor power consumption. Increased cleaning and/or chemical use can also result.

System Water Volume

All chilled water systems need adequate time to recognize a load change, respond to that load change and stabilize, without undesirable short cycling of the compressors or loss of control.

In air conditioning systems, the potential for short cycling usually exists when the building load falls below the minimum chiller plant capacity or on close-coupled systems with very small water volumes.

Some of the things the designer should consider when looking at water volume are the minimum cooling load, the minimum chiller plant capacity during the low load period and the desired cycle time for the compressors.

Assuming that there are no sudden load changes and that the chiller plant has reasonable turndown, a rule of thumb of "gallons of water volume equal to two to three times the chilled water gpm flow rate" is often used.

A properly designed storage tank should be added if the system components do not provide sufficient water volume.

Vibration Mounting

Every Daikin chiller is run tested and compressor vibration is measured and limited to a maximum rate of 0.14 inches per second, which is considerably more stringent than other available compressors. Consequently, floor-mounted spring isolators are not usually required. Rubber mounting pads are shipped with each unit. It is wise to continue to use piping flexible connectors to reduce sound transmitted into the pipe and to allow for expansion and contraction.

AHRI Standard 575 Sound Ratings

Sound data in accordance with AHRI Standard 575 for individual units are available from CSS WEB. Due to the large number of component combinations and variety of applications, sound data is not included in this catalog.

Glycol Operation

The addition of glycol to the chilled water system for freeze protection can be required for special applications. Glycol solutions are required where the evaporating temperatures are below 33°F (1°C).

Certifications and Standards

As with many other Daikin Applied chiller products, the centrifugal chiller models meet all necessary certifications and standards.

AHRI Certification

AHRI Standard 550/590 for Water-Chilling and Heat Pump Water-Heating Packages Using the Vapor Compression Cycle defines certification and testing procedures and performance tolerances of all units that fall within the scope of the standard.

Full AHRI 550/590 participation and certification is an on-going commitment at Daikin. Daikin centrifugal chillers are rated and certified in accordance with the latest edition of AHRI Standard 550/590. The AHRI label affixed to units certifies that the unit will meet the specified performance.

Daikin Selection Tools (DST) for Centrifugal Chillers is used to select and rate chillers for specific job conditions. The program version number and issue date are listed in the AHRI Directory of Certified Applied Air-Conditioning Products available at www.ahridirectory.org. DST ratings are available from your local Daikin Applied sales representative.

Part load performance can be presented in terms of Integrated Part Load Value (IPLV) or Non-Standard Part Load Values (NPLV), both of which are defined by AHRI Standard 550/590.

Based on this standard, and as shown in Figure 20, a typical chiller can operate up to 99% of the time at off-peak conditions and usually spends most of this time at less than 60% of design capacity.

Figure 20: IPLV Defined by AHRI Standard 550/590

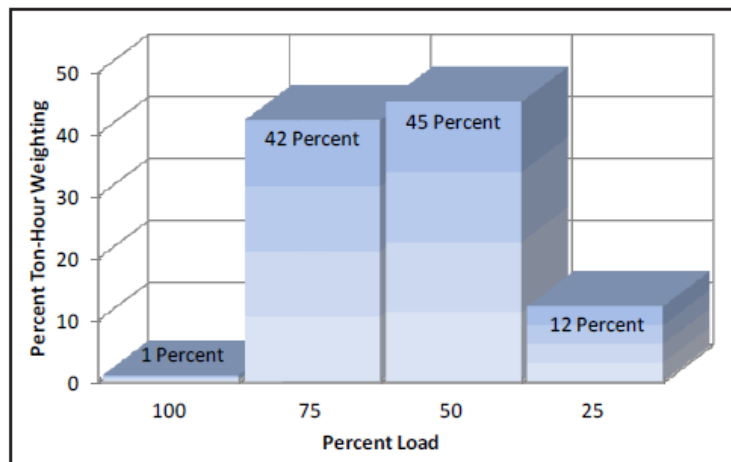

Compliance with ASHRAE Std.90.1

ASHRAE Standard 90.1 was developed to assist owners and designers in making informed choices on a building's design, systems, and equipment selection. Daikin centrifugal chillers can significantly exceed ASHRAE 90.1 minimum efficiency requirements.

LEED®

For building owners who wish to pursue Leadership in Energy and Environmental Design (LEED®) Green Building Certification, the performance of centrifugal chiller models may contribute points towards Energy and Atmosphere (EA) Credits 1 and 4.

Points earned for EA Credit 1 are awarded based on overall building efficiency. The high efficiency of centrifugal chiller models can contribute to the total points earned for this credit.

EA Credit 4 qualification is partially determined by tonnage and refrigerant quantity. Vessel stack and tube count selections will affect the quantity of refrigerant in the chiller. Consult the factory for more information.

Relief Valves

Relief valve connection sizes are 1-inch FPT, with a relief valve (3/8 inch flare) on the top of the oil sump of all units.

All relief valves (including the oil sump) must be piped to the outside of the building in accordance with EN 13136 standard (or ANSI/ASHRAE 15- 2001. The new 2001 standard has revised the calculation method compared to previous issues.)

Twin relief valves, mounted on a transfer valve, are used on the condenser so that one relief valve can be shut off and removed for testing or replacement, leaving the other in operation. Only one of the two valves is in operation at any time. Where four valves are shown, on some large vessels, they consist of two relief valves mounted on each of two transfer valves. Only two relief valves

of the four are active at any time.
 Vent piping is sized for only one valve of the set since only one can be in operation at a time.

Figure 13: Typical Vent Piping

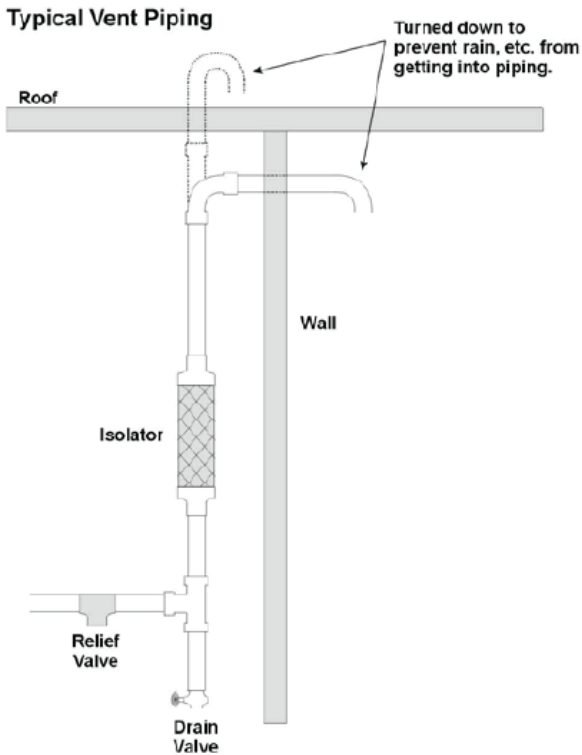

Relief Pipe Sizing (ASHRAE Method)

Relief valve pipe sizing is based on the discharge capacity for the given evaporator or condenser and the length of piping to be run.

Daikin centrifugal chillers have the following relief valve settings and discharge capacity:

- DWSC evaporator (1 valve) and condenser (2 valves piped together to common vent pipe) = 200 psi, 75.5 lb of air/min
- DWDC evaporator (1) = 180 psi, 68.5 lb of air/min
- DWDC condenser(2) = 225 psi, 84.4 lb of air/min
- Note: some large condensers have 4 relief valves

Since the pressures and valve size are fixed for Daikin chillers, the ASHRAE equation can be reduced to the simple table shown below.

Table 8: Relief Valve Piping Sizes

Pipe Size inch (NPT)	1.25	1.5	2	2.5	3	4
Moody Factor	0.0209	0.0202	0.0190	0.0182	0.0173	0.0163
Equivalent length (ft)	2.2	18.5	105.8	296.7	973.6	4117.4

NOTE: A 1-inch pipe is too small to handle these valves. A pipe increaser must be installed at the valve outlet.

Per ASHRAE Standard 15, the pipe size cannot be less than the relief device. The discharge from more than one relief valve can be run into a common header, the area of which shall not be less than the sum of the areas of the connected pipes. For further details, refer to ASHRAE Standard 15.:

The above information is a guide only. Consult local codes and/or latest version of ASHRAE Standard 15 for sizing data.

TECHNICAL SPECIFICATIONS

DWSC, Single Compressor Chiller

Part 1 – GENERAL

1.1 SUMMARY

Section includes design, performance criteria, refrigerants, controls, and installation requirements for water-cooled centrifugal chillers.

1.2 REFERENCES

Comply with the following codes and standards:

DIRECTIVE 2014/35/EU (LVD)

DIRECTIVE 2014/30/EU (EMC)

DIRECTIVE 2006/42/EC (MD)

DIRECTIVE 2014/68/EU (PED)

Electrical & Safety codes EN60204-1/EN61439-1/EN61439-2

DIRECTIVE 2009/125/EC (ECODESIGN)

EN378

AHRI Standard 550/590

1.3 SUBMITTALS

Submittals shall include the following:

A. Dimensioned plan and elevation view drawings, including motor starter cabinet, required clearances, and location of all field piping and electrical connections.

B. Summaries of all auxiliary utility requirements such as: electricity, water, air, etc.

Summary shall indicate quality and quantity of each required utility.

C. Diagram of control system indicating points for field interface and field connection.

Diagram shall fully depict field and factory wiring.

D. Manufacturer's certified performance data at full load plus IPLV or NPLV.

E Before shipment, submit a certification of satisfactory completion of factory run test signed by a company officer. The test shall be performed on an AHRI Certified test stand and conducted according to AHRI Standard 550/590.

F Installation and Operating Manuals.

1.4 QUALITY ASSURANCE

A. Qualifications: Equipment manufacturer must specialize in the manufacture of the products specified and have five years' experience with the equipment and refrigerant offered.

B. Regulatory Requirements: Comply with the codes and standards in Section 1.2.

C. Chiller manufacturer plant shall be ISO Registered.

1.5 DELIVERY AND HANDLING

A. Chillers shall be delivered to the job site completely assembled and charged with refrigerant and oil.

B. Comply with the manufacturer's instructions for rigging and transporting units. Leave protective covers in place until installation.

1.6 WARRANTY

The refrigeration equipment manufacturer's warranty shall be for a period of (one) -- **OR** -- (two) --**Or**-- (five) years from date of equipment start up or 18 months from shipment whichever occurs first. The warranty shall include parts and labor costs for the repair or replacement of defects in material or workmanship.

1.7 MAINTENANCE

Chiller maintenance shall be the responsibility of the owner with the following exceptions:

A. The manufacturer shall provide the first year scheduled oil and filter change if required.

B. The manufacturer shall provide first year purge unit maintenance if required.

Part 2 – PRODUCTS

2.1 ACCEPTABLE MANUFACTURERS

A. Daikin

B. (Approved Equal)

2.2 UNIT DESCRIPTION

Provide and install as shown on the plans a factory-assembled, factory charged, and factory run tested water-cooled packaged chiller. Each unit shall be complete with a single-stage semi hermetic centrifugal compressor with lubrication and control system, factory

mounted (or free standing) starter, evaporator, condenser, refrigerant control device and any other components necessary for a complete and operable chiller package.

2.3 DESIGN REQUIREMENTS

A. General: Provide a complete water-cooled semi hermetic centrifugal compressor water-chilling package as specified herein. Machine shall be provided according to referenced standards Section 1.2. In general, unit shall consist of a compressor, condenser, evaporator, lubrication system, starter and control system.

Note: Chillers shall be charged with a refrigerant such as R-134a

B. Performance: Refer to schedule on the drawings. The chiller shall be capable of stable operation to ten percent of full load with standard AHRI entering condensing water relief without the use of hot gas bypass.

C. Acoustics: Sound pressure levels for the complete unit shall not exceed the following specified levels. Provide the necessary acoustic treatment to chiller as required. Sound data shall be measured according to ARI Standard 575-87. Data shall be in dB. Data shall be the highest levels recorded at all load points. Test shall be in accordance with ARI Standard 575.

Octave Band

63 125 250 500 1000 2000 4000 8000 dba

2.4 CHILLER COMPONENTS

A. Compressor:

1. Unit shall have a single-stage hermetic centrifugal compressor. Casing design shall ensure major wearing parts, main bearings, and thrust bearings are accessible for maintenance and replacement. The lubrication system shall protect machine during coast down period resulting from a loss of electrical power.

2. The impeller shall be statically and dynamically balanced. The compressor shall be vibration tested and not exceed a level of 0.14 IPS.

3. Movable inlet guide vanes actuated by an internal oil pressure driven piston shall accomplish unloading. Compressors using an unloading system that requires penetrations through the compressor housing or linkages, or both that must be lubricated and adjusted are acceptable provided the manufacturer provides a five year inspection agreement consisting of semi-annual inspection, lubrication, and annual change out of any compressor seals. A statement of inclusion must accompany any quotations.

4. If the compressor is not equipped with guide vanes for each stage and movable discharge diffusers, then furnish hot gas bypass and select chillers at 5% lower kW/ton than specified to compensate for bypass inefficiency at low loads.

B. Lubrication System: The compressor shall have an independent lubrication system to provide lubrication to all parts requiring oil. Provide a heater in the oil sump to maintain oil at sufficient temperature to minimize affinity of refrigerant, and a thermostatically controlled water-cooled oil cooler. Coolers located inside the evaporator or condenser are not acceptable due to inaccessibility. A positive displacement oil pump shall be powered through the unit control transformer.

C. Refrigerant Evaporator and Condenser:

1. Evaporator and condenser shall be of the shell-and-tube type, designed, constructed, tested and stamped according to the requirements of the PED standard (2014/68/EU).

Regardless of the operating pressure, the refrigerant side of each vessel will bear the PED stamp indicating compliance with the code and indicating a test pressure of 1,1 times the working pressure, but not less than 100 psig. Provide intermediate tube supports at a maximum of 24 inch spacing.

2. Tubes shall be enhanced for maximum heat transfer, rolled into steel tube sheets and sealed with Loctite® or equal sealer. The tubes shall be individually replaceable. [DWDC: Tubes must be secured to the intermediate supports without rolling.]

3. Provide isolation valves and sufficient volume to hold the full refrigerant charge in the condenser or provide a separate pumpout system with storage tank.

4. The water sides shall be designed for a minimum of 10bar (equivalent to 150 psi) or as specified elsewhere. Vents and drains shall be provided.

5. Evaporator minimum refrigerant temperature shall be 0.5°C (33°F).

6. An electronic refrigerant expansion valve shall control refrigerant flow to the evaporator. Fixed orifice devices or float controls with hot gas bypass are not acceptable because of inefficient control at low load conditions. The liquid line shall have a moisture indicating sight glass.

7. The evaporator and condenser shall be separate shells. A single shell containing both vessel functions is not acceptable because of the possibility of internal leaks.

8. Reseating type spring loaded pressure relief valves according to EN 13136 standard code shall be furnished. The evaporator shall be provided with single or multiple valves. The condenser shall be provided with dual relief valves equipped with a transfer valve so one valve can be removed for testing or replacement without loss of refrigerant or removal of refrigerant from the vessel. Rupture disks are not acceptable.

9. The evaporator, suction line, and any other component or part of a component subject to condensing moisture shall be insulated with 20mm (3/4 inch) closed cell insulation. All joints and seams shall be carefully sealed to form a vapor barrier.
10. Provide factory-mounted thermal dispersion flow switches on each vessel to prevent unit operation with no flow.

D. Prime Mover: Squirrel cage induction motor of the hermetic type of sufficient size to efficiently fulfill compressor horsepower requirements. Motor shall be liquid refrigerant cooled with internal thermal overload protection devices embedded in the winding of each phase. Motor shall be compatible with the starting method specified hereinafter. If the Contractor chooses to provide an open drive motor or compressor, verify in the submittal that the scheduled chiller room ventilation system will accommodate the additional heat and maintain the equipment room at design indoor temperature based on 95° F outdoor ambient ventilation air available.

If additional cooling is required, manufacturer shall be responsible for the installation, wiring and controls of a cooling system. Chiller selection shall compensate for tonnage and efficiency loss to make certain the owner is not penalized.

E. Motor Starter:

1. The main motor starter is to be factory mounted and fully wired to the chiller components and factory tested during the run test of the unit.

-- OR --

The main motor starter is to be furnished by the chiller manufacturer and shipped loose for floor mounting and field wiring to the chiller package. It shall be freestanding

2. For open drive air-cooled motors the chiller manufacturer shall be responsible for providing the cooling of the refrigeration machinery room. The sensible cooling load shall be based on the total heat rejection to the atmosphere from the refrigeration units.
3. For open motor units, an oil reservoir shall collect any oil and refrigerant that leaks past the seal. A float device shall be provided to open when the reservoir is full, directing the refrigerant/oil mixture back into the compressor housing. Manufacturer shall warrant the shaft seal, reservoir, and float valve system against leakage of oil and refrigerant to the outside of the refrigerating unit for a period of 5 years from the initial start-up including parts and labor to replace a defective seal and any refrigerant required to trim the charge original specifications.
4. The starter must comply with the requirements of Section 1.2.
5. The starter shall be coordinated with the chiller package(s) making certain all terminals are properly marked according to the chiller manufacturer's wiring diagrams.
6. The starters shall be equipped with redundant motor control relays (MCR) with coils in parallel. The relays interconnect the starters with the unit control panels and directly operate the main motor contactors. The MCRs shall constitute the only means of energizing the motor contacts.
8. The main contactors shall have a normally open and a normally closed auxiliary contact rated at 125VA pilot duty at 115 VAC. An additional set of normally open contacts shall be provided for each MCR.
9. There shall be electronic overloads in each phase set at 107% of the rated load amps of each motor. Overloads shall be manual reset and shall de-energize the main contactors when the overcurrent occurs. The overloads shall be adjustable and selected for mid-range. Overloads shall be adjusted for a locked rotor trip time of 8 seconds at full voltage and must trip in 60 seconds or less at reduced voltage (33% of delta LRA).
10. Each starter shall have a current transformer and adjustable voltage dropping resistor(s) to supply a 5.0 VAC signal at full load to the unit control panels.
11. Each starter shall be equipped with a line-to-115 VAC control transformer, fused in both the primary and secondary, to supply power to the control panels, oil heaters and oil pumps.
12. Each starter shall have phase failure and reversal protection

-- OR --

Variable Frequency Drive

The chiller shall be equipped with a Variable Frequency Drive (VFD) to automatically regulate compressor speed in response to cooling load and compressor pressure lift. The chiller control shall coordinate compressor speed and guide vane position to optimize chiller efficiency.

1. A digital regulator shall provide V/Hz control.
2. The VFD shall have 110% continuous overload of continuous amp rating with no time limit, PWM (pulse width modulated) output, IGBT (insulated gate bipolar transistors) power technology, full power rating at 2kHz, DC bus inductor (choke), and wireless construction.

Medium Voltage (601 through 5000 volts) and High Voltage (5001 through 7200 volts).

The starter shall be:

1. Solid-State Reduced Voltage - Starter shall be furnished with silicon controlled rectifiers (SCR) connected for starting and include a bypass contactor. When operating speed is reached, the bypass contactor shall be energized removing the SCRs from the circuit during normal running.
2. The starter shall be coordinated with the chiller package(s) making certain all terminals are properly marked according to the chiller manufacturer's wiring diagrams.

3. The starters shall be equipped with redundant motor control relays (MCR) with coils in parallel. The relays interconnect the starters with the unit control panels and directly operate the main motor contactors. The MCRs shall constitute the only means of energizing the motor contacts.
4. The main contactors shall have a normally open and a normally closed auxiliary contact rated at 125VA pilot duty at 115 VAC. An additional set of normally open contacts shall be provided for each MCR.
5. There shall be electronic overloads in each phase set at 107% of the rated load amps of each motor. Overloads shall be manual reset and shall de-energize the main contactors when the overcurrent occurs. The overloads shall be adjustable and selected for mid-range. Overloads shall be adjusted for a locked rotor trip time of 8 seconds at full voltage and must trip in 60 seconds or less at reduced voltage (33% of delta LRA).
6. Each starter shall have a current transformer and adjustable voltage dropping resistor(s) to supply a 5.0 VAC signal at full load to the unit control panels.
7. Each starter shall be equipped with a line-to-115 VAC control transformer, fused in both the primary and secondary, to supply power to the control panels, oil heaters and oil pumps.
8. Each starter shall include the following:
 - a) Phase failure and reversal protection
 - b) Load break disconnect switch
 - c) Current limiting power fuses

--OR--

Across-the-Line type with primary contactor allowing locked rotor amps to reach the motor when energized.

--OR--

Autotransformer type factory wired to the 65% tap with drawout magnetic, three-pole, vacuum break shorting contactor, drawout magnetic, two-pole, vacuum break starting contactor, and open delta starting auto-transformer factory set at 65%.

--OR--

Primary Reactor type with drawout magnetic, three-pole, vacuum break shorting assembly, and three-phase starting reactor, factory set at the 65% tap. All medium and high voltage starters shall have the following components:

Main Control Relays

Redundant motor control relays with coils in parallel and contacts in series to interlock the starter with the chiller. These two relays shall constitute the only means of energizing the motor contractors. No other devices (manual or automatic) with the capability of energizing the starter can be used. The starter is controlled by the unit microprocessor.

Motor Protection and Overloads

The starter shall include overload protection functions. These controls include:

- Solid state overload (overcurrent) protection
- Phase unbalance protection
- Phase reversal and phase loss protection.
- Adjustable overload to closely match motor performance
- Three current transformers to measure motor current and a fourth current transformer for input to the chiller microprocessor.

Undervoltage (UV) Relay

The undervoltage relay is an adjustable three-phase protection system that is activated when the voltage falls below a predetermined safe value and is factory set at 85% of nominal.

Control Voltage Transformer

The starter is provided with a 3KVA control transformer with both secondary and primary fuses to supply control power to the chiller.

Additional Standard Components

- Mechanical type solderless connectors to handle wire sizes indicated by the NEC.
- Three isolated vertical line contactors
- Three-pole, gang operated non-load break isolating switch
- Three vertically mounted current limiting power fuse blocks (fuses included)
- Magnetic three-pole, vacuum break contactor
- Single phase control circuit transformer
- Vertically mounted control circuit primary current limiting fuses
- Current transformers
- Load terminals
- Control circuit terminal blocks and secondary fuses
- Phase failure and reversal relay

G. CHILLER CONTROLLER

The chiller shall have centralized control consisting of a unit controller, a compressor controller and a 12-inch color touch screen for operator interface with the control system.

MicroTech 4 Controller. The new MicroTech 4 controller is installed as standard.

MicroTech 4 built-in terminal has the following features:

- Liquid crystal display with white back lighting, supports Unicode fonts for multi-lingual;
- Key-pad consisting of 3 keys;
- Push'n'roll control for an increased usability;
- Flash memory to protect the data;
- Password access to modify the setting;
- Application security to prevent application tampering or hardware usability with third party applications;
- Alarm history memory to allow an easy fault analysis.

The controller gives the possibility to check the most relevant control parameters and to modify unit set points. A built-in display shows unit operating status. Additionally, temperatures and pressures of water, refrigerant, programmable values, set points can be accessed based on a preset list of user profiles.

A sophisticated software with adaptive logic, selects the most energy efficient combination of compressors and electronic expansion valve position to keep stable operating conditions to maximize unit energy efficiency and reliability. MicroTech 4 protects critical components based on external signals from onboard sub system (such as motor temperatures, refrigerant and oil pressures and temperatures, correctness of phase sequence, pressure switches and freezing of heat exchanger).

The input coming from high-pressure switches cuts all digital output from the controller in less than 50ms, as an additional security for the equipment. Fast program cycle (less than 200ms) for a precise monitoring of the system and sub systems. Floating point calculations supported for increased accuracy in Pressure / Temperature conversions.

Main control features are (for more information refer to Unit Control Manual):

- Management of the compressor stepless capacity;
- Control of cooling or heating leaving water temperatures;
- Optimized management of compressor load;
- Soft Load (optimized management of the compressor load during the start-up);
- Start at high heat exchanger water temperature;
- Re-start in case of power failure (automatic/manual);
- Visualization of:
 - cooling and heating entering/leaving water temperature of heat exchangers;
 - outdoor ambient temperature;
 - condensing-evaporating temperature and pressure, suction and discharge superheat for each circuit;
 - hours and starts counter for compressors and pumps;
 - status safety devices;
- Return Reset (Set Point Reset based on return water temperature);
- Set point Reset (optional);
- Unit enabled to work in partial failure condition;
- Managed operations during critical conditions:
 - High ambient temperature;
 - High thermal load;
 - Startup with high and low differential operating conditions;
 - Startup with high entering water temperature in cooling mode;
 - Startup with low entering water temperature in heating mode.

Control additional features

- Application and system upgrade with commercial SD cards;
- Save/Restore of configuration parameters with a commercial SD card;
- Ethernet port for remote or local servicing using standard web browsers;
- Two different sets of default parameters could be stored for easy restore;
- Daikin on Site connectivity for cloud-based services.

Safety device / logic (for more information refer to Unit Control Manual):

- High pressure (switch);
- High pressure (transducer);
- Low pressure (transducer);
- High discharge temperature;
- High motor winding temperature;

- Low pressure ratio;
- High oil pressure differential;
- Low oil pressure;
- No pressure changes at start.

System security:

- Phase monitor;
- Freeze protection.

Regulation type: Proportional-Integral-Derivative (PID) type based on the evaporator leaving water temperature set point (cooling mode) or based on the condenser leaving water temperature set point (heating mode).

Supervising systems (on request) MicroTech 4 remote communication: MicroTech 4 controlled is capable to communicate with BMS systems based on the most common protocols such as: Modbus, Lon Works, BACnet IP and MS/TP (class 4), Ethernet TCP/IP. Communication cards (optional) are to be selected according to the required communication protocol.

Touch Screen panel (standard) The chiller is provided with a touch screen panel. The panel is fitted inside the unit control panel for easy access. It is provided together with the App already installed allowing a ready connection to the unit controller.

PART 3 — EXECUTION

3.1 INSTALLATION

- A. Install according to manufacturer’s requirements, shop drawings, and Contract Documents.
- B. Adjust chiller alignment on concrete foundations, sole plates or subbases as called for on drawings.
- C. Arrange the piping on each vessel to allow for dismantling the pipe to permit head removal and tube cleaning.
- D. Furnish and install necessary auxiliary water piping for oil cooler.
- E. Coordinate electrical installation with electrical contractor.
- F. Coordinate controls with control contractor.
- G. Provide all materiel required to ensure a fully operational and functional chiller.

3.2 START-UP

- A. Units shall be factory charged with the proper refrigerant and oil.
- B. Factory Start-Up Services: The manufacturer shall provide factory authorized supervision for as long a time as is necessary to ensure proper operation of the unit, but in no case for less than two full working days. During the period of start-up, the start-up technician shall instruct the owner’s representative in proper care and operation of the unit.

For more information email info@daikinapplied.uk or visit www.daikinapplied.uk

For all Daikin Applied UK,
Daikin Applied Service &
Spares enquiries call us on:
0345 565 2700



Daikin Europe N.V. participates in the Eurovent Certified Performance programme for Liquid Chilling Packages and Hydronic Heat Pumps, Fan Coil Units and Variable Refrigerant Flow systems. Check ongoing validity of certificate:
www.eurovent-certification.com

The present publication is drawn up by way of information only and does not constitute an offer binding upon Daikin Europe N.V. Daikin Europe N.V. has compiled the content of this publication to the best of its knowledge. No express or implied warranty is given for the completeness, accuracy, reliability or fitness for particular purpose of its content and the products and services presented therein. Specifications are subject to change without prior notice. Daikin Europe N.V. explicitly rejects any liability for any direct or indirect damage, in the broadest sense, arising from or related to the use and/or interpretation of this publication. All content is copyrighted by Daikin Europe N.V.

